

BASE

AISI 304 stainless steel, sandblasted matte finish.

THREADED STEM AND ADJUSTABLE SLEEVE

AISI 303 stainless steel, sandblasted matte finish, supplied assembled.
Glued stainless steel assembly screw.

NO-SLIP DISK

NBR rubber (PERBUNAN), vulcanised to the base, hardness 80±5 Shore A, black colour.

FEATURES

- The convex shape of the base in the stem supporting point reduces the deposit of dirt and simplifies the cleaning operations.
- The adjustable sleeve covers the threading of the stem and it reduces the deposit of dirt.
- The NBR rubber no-slip disk is firmly bonded to the base by means of a vulcanisation process and a glued metal screw. This makes the two parts integral and prevents any solid or liquid substances from infiltrating into the base.

TECHNICAL DATA

The load values reported in the table are the result of a series of tests where a vertical load is applied to the stem and distributed on the horizontal plane of the base. If the values are exceeded a deformation of the base can occur first on the metal sheet and therefore also on the no-slip disk plastic material.



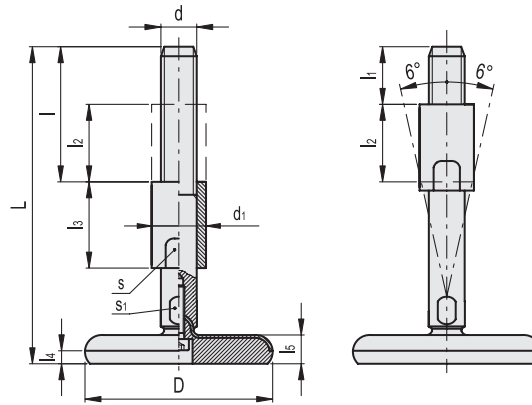

Code	Description	D	d	L	l	l1	l2	l3	l4	l5	d1	s	s1	Max. limit static load [N]	⚖️
409432	LMRS.60-SST-M16x125	60	M16	125	45	13	32	45	4	16	24	20	12	27000	351
409434	LMRS.60-SST-M16x150	60	M16	150	45	13	32	45	4	16	24	20	12	27000	391
409436	LMRS.60-SST-M16x175	60	M16	175	45	13	32	45	4	16	24	20	12	27000	431
409438	LMRS.60-SST-M16x200	60	M16	200	45	13	32	45	4	16	24	20	12	27000	471
409532	LMRS.80-SST-M16x128	80	M16	128	45	13	32	45	5	18	24	20	12	24000	460
409534	LMRS.80-SST-M16x153	80	M16	153	45	13	32	45	5	18	24	20	12	24000	500
409536	LMRS.80-SST-M16x178	80	M16	178	45	13	32	45	5	18	24	20	12	24000	540
409538	LMRS.80-SST-M16x203	80	M16	203	45	13	32	45	5	18	24	20	12	24000	580
409552	LMRS.80-SST-M20x152	80	M20	152	56	16	40	56	5	18	30	24	16	24000	676
409554	LMRS.80-SST-M20x177	80	M20	177	56	16	40	56	5	18	30	24	16	24000	738
409556	LMRS.80-SST-M20x202	80	M20	202	56	16	40	56	5	18	30	24	16	24000	800
409558	LMRS.80-SST-M20x252	80	M20	252	56	16	40	56	5	18	30	24	16	24000	924
409572	LMRS.80-SST-M24x176	80	M24	176	67	19	48	67	5	18	35	30	20	24000	981
409574	LMRS.80-SST-M24x226	80	M24	226	67	19	48	67	5	18	35	30	20	24000	1160
409576	LMRS.80-SST-M24x276	80	M24	276	67	19	48	67	5	18	35	30	20	24000	1339
409632	LMRS.100-SST-M16x130	100	M16	130	45	13	32	45	6	20	24	20	12	21000	591
409634	LMRS.100-SST-M16x155	100	M16	155	45	13	32	45	6	20	24	20	12	21000	631
409636	LMRS.100-SST-M16x180	100	M16	180	45	13	32	45	6	20	24	20	12	21000	671
409638	LMRS.100-SST-M16x205	100	M16	205	45	13	32	45	6	20	24	20	12	21000	711
409652	LMRS.100-SST-M20x155	100	M20	155	56	16	40	56	6	20	30	24	16	21000	807
409654	LMRS.100-SST-M20x180	100	M20	180	56	16	40	56	6	20	30	24	16	21000	869
409656	LMRS.100-SST-M20x205	100	M20	205	56	16	40	56	6	20	30	24	16	21000	931
409658	LMRS.100-SST-M20x255	100	M20	255	56	16	40	56	6	20	30	24	16	21000	1055
409672	LMRS.100-SST-M24x179	100	M24	179	67	19	48	67	6	20	35	30	20	21000	1112
409674	LMRS.100-SST-M24x229	100	M24	229	67	19	48	67	6	20	35	30	20	21000	1231
409676	LMRS.100-SST-M24x279	100	M24	279	67	19	48	67	6	20	35	30	20	21000	1470



Levelling feet and supports