

Photoelectric sensor
Photoelectric Sensor for Plastic Fibers
DF-G2-PS-2M

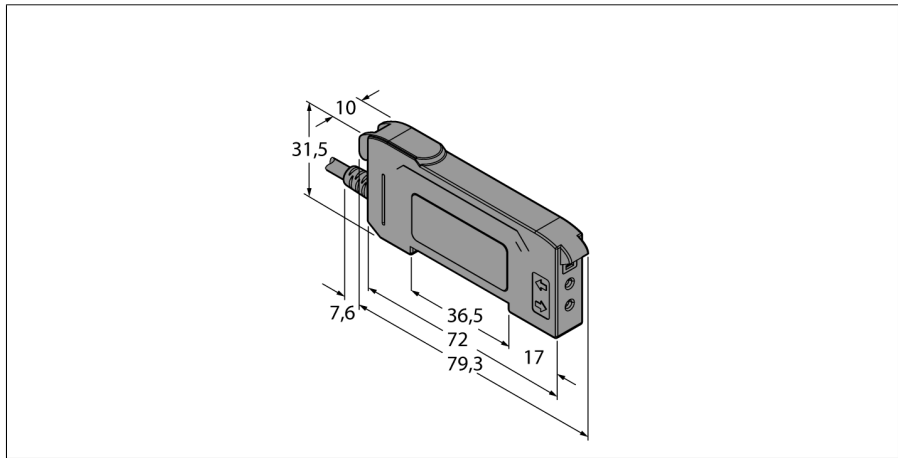

- Cable 2 m
- Visible red light
- Programming via teach cable or multi-function button
- Operating voltage: 10...30 VDC
- PNP output
- Light/dark operation

Wiring Diagram

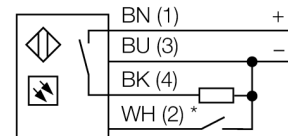

* external programming

Type designation	DF-G2-PS-2M
Ident no.	3087556
Operating mode	Photoelectric sensor for plastic fibers
Light type	red
Wavelength	635 nm
Ambient temperature	-10...+55 °C
Operating voltage	10...30 VDC
Residual ripple	< 10 % U _s
DC rated operational current	≤ 40 mA
Short-circuit protection	yes
Reverse polarity protection	yes
Output function	NO contact, PNP
Current output	100mA
Switching frequency	50 kHz
Readiness delay	≤ 500 ms
Response time typical	< 0.01 ms
Approvals	CE, cULus listed
Design	Rectangular, DF-G1
Dimensions	79.3 mm x 10 mm x 33 mm
Housing material	Plastic, ABS, Black
Electrical connection	Cable, PVC
Cable length	2 m
Cable cross section	4 mm ²
Protection class	IP50
Special features	Pushbutton
Switching state	LED yellow
Excess gain indication	7-digit LED

Functional principle

Glass or plastic fibers are the optimum choice for high-temperature applications and limited spaces. Optical fibers transfer the light from the sensor to a remote object. Single optical fibers are suited for opposed sensing mode, while bifurcated optical fibers are best suited for diffuse sensing mode.

Photoelectric sensor
Photoelectric Sensor for Plastic Fibers
DF-G2-PS-2M

Function accessories

Type code	Ident no.	Description	
PBT16U	3042822	Plastic fibre-optic sensor, operating mode: Diffuse mode, threaded sleeve M3 x 0.75 mm, field wireable wire without end tip, polyethylene sheath, ambient temperatures -30 °C...+70 °C	
PBT26U	3026080	Plastic fiber, sensing mode: Diffuse mode, threaded bush M3 x 0.75 mm, preassembled wire without end tip, polyethylene jacket, ambient temperatures -30 °C...+70 °C	
PBT46U	3025967	Plastic fibre-optic sensor, operating mode: Diffuse mode, threaded sleeve M3 x 0.75 mm, field wireable wire without end tip, polyethylene sheath, ambient temperatures -30 °C...+70 °C	
PBT66U	3039982	Plastic fibre-optic sensor, operating mode: Diffuse mode, threaded sleeve M6 x 0.75 mm, pre-assembled wire without end tip, polyethylene sheath, ambient temperatures -30 °C...+70 °C	
PIT16U	3039983	Plastic fibre-optic sensor, operating mode: Opposed mode, threaded sleeve M3 x 0.5 mm, field wireable wire without end tip, polyethylene sheath, ambient temperatures -30 °C...+70 °C	

Photoelectric sensor
Photoelectric Sensor for Plastic Fibers
DF-G2-PS-2M

Function accessories

Type code	Ident no.	Description	
PIT26U	3026079	Plastic fiber, sensing mode: Opposed mode, threaded bush M3 x 0.5 mm, preassembled wire without end tip, polyethylene jacket, ambient temperatures -30 °C...+70 °C	
PIT46U	3026034	Plastic fibre-optic sensor, operating mode: Opposed mode, threaded sleeve M3 x 0.5 mm, field wireable wire without end tip, polyethylene sheath, ambient temperatures -30 °C...+70 °C	
PIT66U	3039899	Plastic fibre-optic sensor, operating mode: Opposed mode, threaded sleeve M3 x 0.5 mm, field wireable wire without end tip, polyethylene sheath, ambient temperatures -30 °C...+70 °C	