

PIANO SWITCHES (FULL PITCH)

CFP

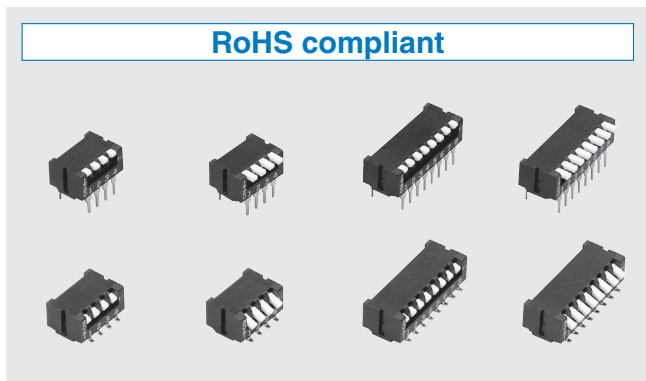

RoHS compliant

FEATURES

- RoHS compliant
- High-reliability

APPLICATIONS

- Communication devices, Air-conditioning equipment, Vending machines and various control equipment

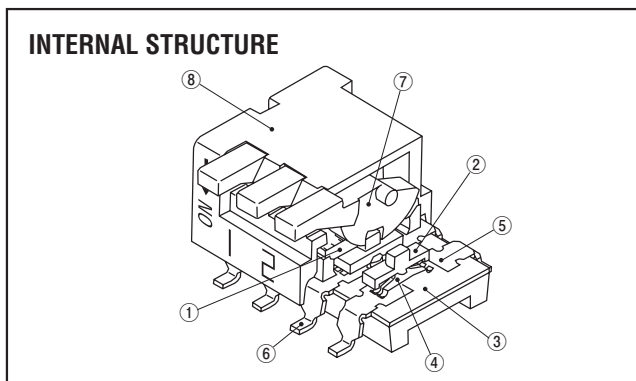

Part name	Material	Flammability
① Cover	Polyphenylenesulphide	UL94V-0
② Slider	Polyamide	
③ Housing	Polyphenylenesulphide	
④ Slider contact	Copper alloy, Gold-plated	-
⑤ Fixed contact		
⑥ Terminal pin		
⑦ Piano lever	Polyamide	UL94V-0
⑧ Piano cover	Polyphenylenesulphide	

PART NUMBER DESIGNATION

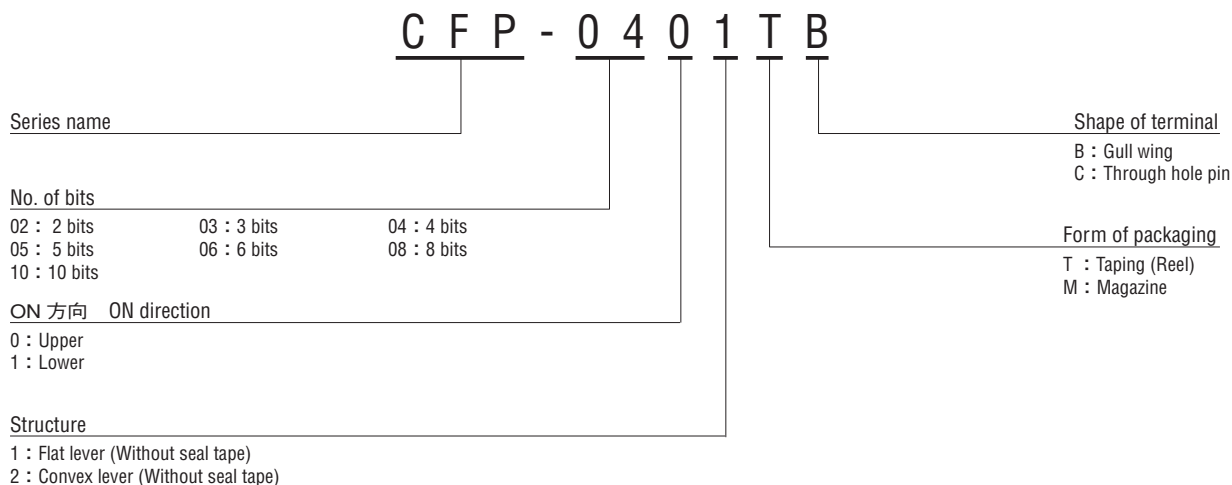

※ Please refer to the LIST OF PART NUMBERS when placing orders.

LIST OF PART NUMBERS

No. of bits	ON direction	Structure	Form of packaging	Shape of terminals		Pieces in package
				B (Gull wing)	C (Through hole pins)	
2	Upper	Flat lever (without seal tape)	Taping	CFP-0201TB		500 pcs./reel
			Magazine	CFP-0201MB	CFP-0201MC	62 pcs./stick
	Convex lever (without seal tape)	Taping	CFP-0202TB		500 pcs./reel	
		Magazine	CFP-0202MB	CFP-0202MC	62 pcs./stick	
	Lower	Flat lever (without seal tape)	Taping	CFP-0211TB		500 pcs./reel
			Magazine	CFP-0211MB	CFP-0211MC	62 pcs./stick
Convex lever (without seal tape)	Taping	CFP-0212TB		500 pcs./reel		
	Magazine	CFP-0212MB	CFP-0212MC	62 pcs./stick		
3	Upper	Flat lever (without seal tape)	Taping	CFP-0301TB		500 pcs./reel
			Magazine	CFP-0301MB	CFP-0301MC	46 pcs./stick
	Convex lever (without seal tape)	Taping	CFP-0302TB		500 pcs./reel	
		Magazine	CFP-0302MB	CFP-0302MC	46 pcs./stick	
	Lower	Flat lever (without seal tape)	Taping	CFP-0311TB		500 pcs./reel
			Magazine	CFP-0311MB	CFP-0311MC	46 pcs./stick
Convex lever (without seal tape)	Taping	CFP-0312TB		500 pcs./reel		
	Magazine	CFP-0312MB	CFP-0312MC	46 pcs./stick		
4	Upper	Flat lever (without seal tape)	Taping	CFP-0401TB		500 pcs./reel
			Magazine	CFP-0401MB	CFP-0401MC	36 pcs./stick
	Convex lever (without seal tape)	Taping	CFP-0402TB		500 pcs./reel	
		Magazine	CFP-0402MB	CFP-0402MC	36 pcs./stick	
	Lower	Flat lever (without seal tape)	Taping	CFP-0411TB		500 pcs./reel
			Magazine	CFP-0411MB	CFP-0411MC	36 pcs./stick
Convex lever (without seal tape)	Taping	CFP-0412TB		500 pcs./reel		
	Magazine	CFP-0412MB	CFP-0412MC	36 pcs./stick		
5	Upper	Flat lever (without seal tape)	Taping	CFP-0501TB		500 pcs./reel
			Magazine	CFP-0501MB	CFP-0501MC	30 pcs./stick
	Convex lever (without seal tape)	Taping	CFP-0502TB		500 pcs./reel	
		Magazine	CFP-0502MB	CFP-0502MC	30 pcs./stick	
	Lower	Flat lever (without seal tape)	Taping	CFP-0511TB		500 pcs./reel
			Magazine	CFP-0511MB	CFP-0511MC	30 pcs./stick
Convex lever (without seal tape)	Taping	CFP-0512TB		500 pcs./reel		
	Magazine	CFP-0512MB	CFP-0512MC	30 pcs./stick		
6	Upper	Flat lever (without seal tape)	Taping	CFP-0601TB		500 pcs./reel
			Magazine	CFP-0601MB	CFP-0601MC	26 pcs./stick
	Convex lever (without seal tape)	Taping	CFP-0602TB		500 pcs./reel	
		Magazine	CFP-0602MB	CFP-0602MC	26 pcs./stick	
	Lower	Flat lever (without seal tape)	Taping	CFP-0611TB		500 pcs./reel
			Magazine	CFP-0611MB	CFP-0611MC	26 pcs./stick
Convex lever (without seal tape)	Taping	CFP-0612TB		500 pcs./reel		
	Magazine	CFP-0612MB	CFP-0612MC	26 pcs./stick		
8	Upper	Flat lever (without seal tape)	Taping	CFP-0801TB		500 pcs./reel
			Magazine	CFP-0801MB	CFP-0801MC	20 pcs./stick
	Convex lever (without seal tape)	Taping	CFP-0802TB		500 pcs./reel	
		Magazine	CFP-0802MB	CFP-0802MC	20 pcs./stick	
	Lower	Flat lever (without seal tape)	Taping	CFP-0811TB		500 pcs./reel
			Magazine	CFP-0811MB	CFP-0811MC	20 pcs./stick
Convex lever (without seal tape)	Taping	CFP-0812TB		500 pcs./reel		
	Magazine	CFP-0812MB	CFP-0812MC	20 pcs./stick		
10	Upper	Flat lever (without seal tape)	Taping	CFP-1001TB		500 pcs./reel
			Magazine	CFP-1001MB	CFP-1001MC	16 pcs./stick
	Convex lever (without seal tape)	Taping	CFP-1002TB		500 pcs./reel	
		Magazine	CFP-1002MB	CFP-1002MC	16 pcs./stick	
	Lower	Flat lever (without seal tape)	Taping	CFP-1011TB		500 pcs./reel
			Magazine	CFP-1011MB	CFP-1011MC	16 pcs./stick
Convex lever (without seal tape)	Taping	CFP-1012TB		500 pcs./reel		
	Magazine	CFP-1012MB	CFP-1012MC	16 pcs./stick		

☐ : Not manufactured

※ Verify the above part numbers when placing orders.

Taping and magazine version can be supplied only in reel or stick units.

CFP

PIANO SWITCHES (FULL PITCH)

STANDARD SPECIFICATIONS

Operating temp. range	- 40 ~ 85 °C	
Storage temp. range		
Sealing	Non-washable	
Net weight	Approx. 0.55 g (CFP-02) Approx. 0.86 g (CFP-04) Approx. 1.19 g (CFP-06) Approx. 1.90 g (CFP-10)	Approx. 0.70 g (CFP-03) Approx. 1.03 g (CFP-05) Approx. 1.54 g (CFP-08)

ELECTRICAL CHARACTERISTICS

Contact rating Non-switching Switching Minimum	DC50 V 100 mA DC6 V, 100 mA DC24 V, 25 mA DC20 mV 1 µA
Contact resistance	50 m Ω maximum
Insulation resistance	1000 M Ω (DC100 V) minimum
Dielectric strength	AC500 V, 60 s

MECHANICAL CHARACTERISTICS

Operation angle	21 °
Operation force	7 N {0.71 kgf} maximum
Stop strength	10 N {1.02 kgf} 60 s
Solderability	245 ± 3 °C, 2 ~ 3 s
Soldering heat	Reflow : 255 °C (Peak temperature) Flow : 260 ± 3 °C, 5 ~ 6 s, two times maximum (Please refer to the profile below)
	Manual soldering : 350 ± 10 °C, 3 ~ 4 s
Shear (Adhesion)	5 N {0.51 kgf} 10 s
Substrate bending	Width 90 mm, bend 3 mm, 5 s, 1 time
Pull-off strength	5 N {0.51 kgf} 10 s

{ } : Reference only

ENVIRONMENTAL CHARACTERISTICS

Vibration	(Amplitude) 1.5 mmor (Acceleration) 98 m/s ² , 10-500 Hz, 3 directions for 10 cycles each
Shock	490 m/s ² , 11 ms, 6 directions for 3 times each
Load life	Continuous load 1000 cycles, DC6 ± 0.5 V, 100 ± 10 mA
Humidity	-10 ~ 65 °C, Relative humidity 0 ~ 96 %, 24 h for 10 cycles
High temp. exposure	85 °C, 96 h
Low temp. exposure	-40 °C, 96 h
Thermal shock	-40 (0.5 h) ~ 85 °C (0.5 h), 5 cycles

<Reflow profile for soldering heat evaluation>

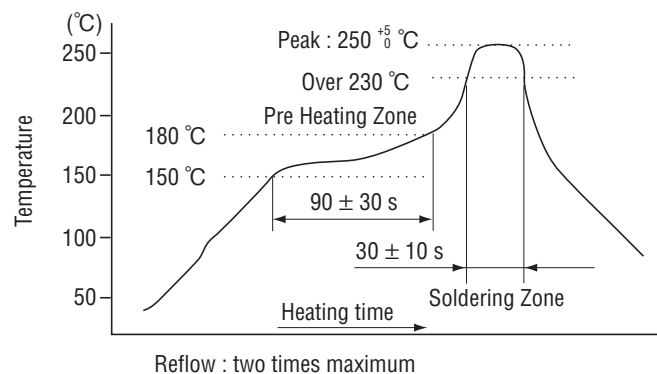

CFP PIANO SWITCHES (FULL PITCH)

OUTLINE DIMENSIONS

Flat lever, Gull wing

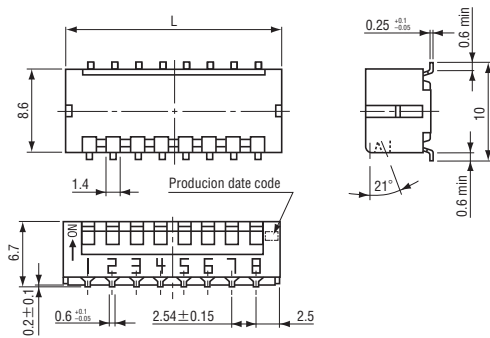

Convex lever, Gull wing

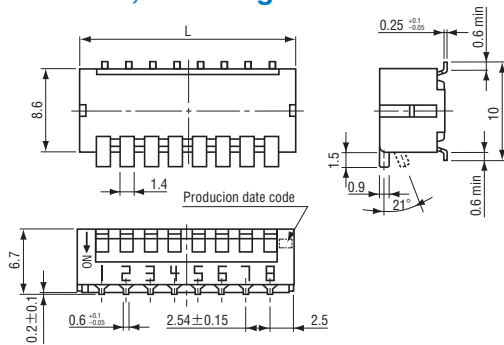

Part number	Schematic	No. of bits.	L dimension
CFP-02		2	7.5
CFP-03		3	10.05
CFP-04		4	12.6
CFP-05		5	15.15

RECOMMENDED P.C.B. PAD DIMENSIONS

(Unit : mm)

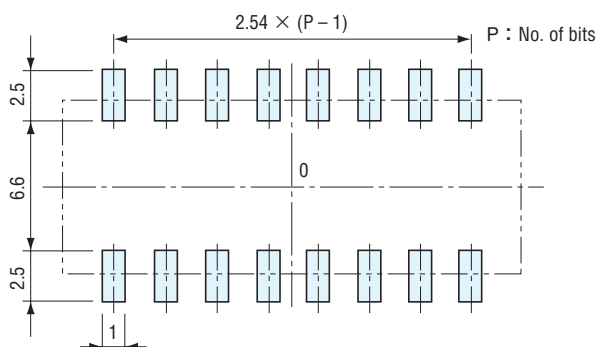

Unless otherwise specified, tolerance : ± 0.3 (Unit : mm)

Flat lever, Through hole pin

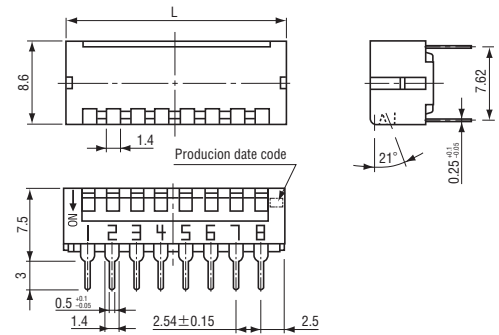

Convex lever, Through hole pin

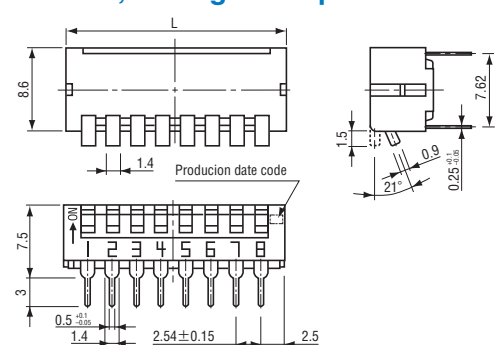

Part number	Schematic	No. of bits.	L dimension
CFP-06		6	17.7
CFP-08		8	22.8
CFP-10		10	27.9

SIZE OF P.C.B. PROCESSING

(Unit : mm)

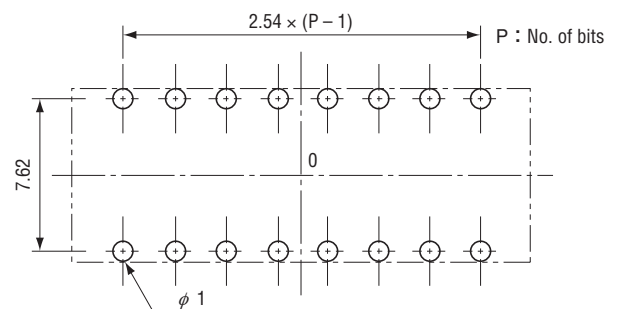

CFP

PIANO SWITCHES (FULL PITCH)

PACKAGING SPECIFICATIONS

<Taping packaging specifications>

- Taping version are packaged in 500 pcs. per reel. Orders will be accepted for units of 500 pcs., i.e., 500, 1000, 1500 pcs., etc.

- Taping version is boxed with 1 reel.

Maximum number of consecutive missing pieces = 2
 Leader length and reel dimension are shown in the diagrams below:

● Embossed tape dimensions

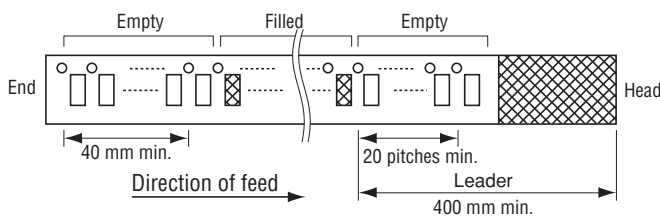

● Reel dimensions

(Unit: mm)

(Conforms to JIS C 0806-3)

(In accordance with EIAJ ET-7200A)

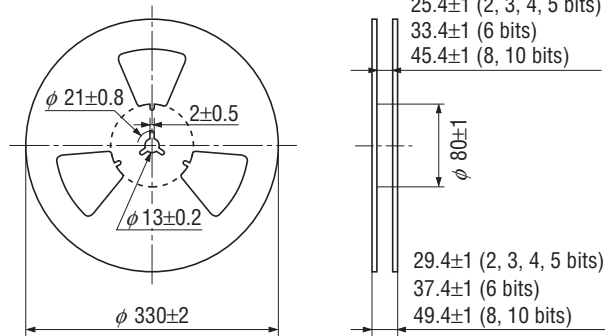

● 2 bits, 3 bits, 4 bits, 5 bits

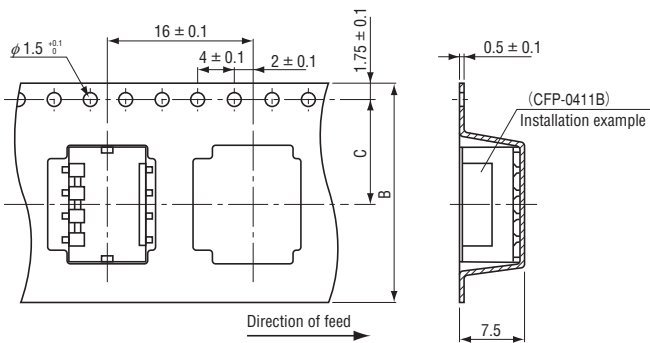

● 6 bits, 8 bits, 10 bits

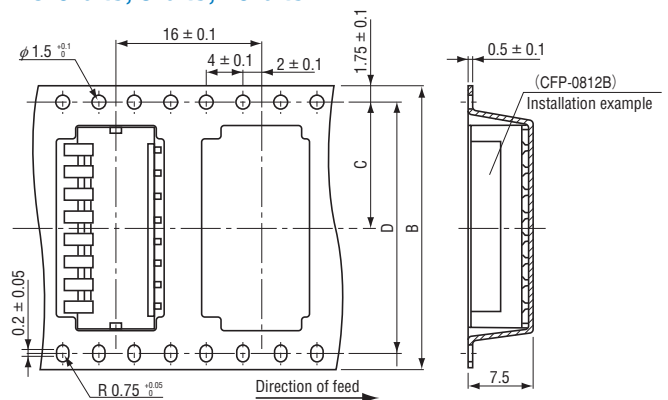

No. of bits	B	C	D
2, 3, 4, 5	24	11.5 ± 0.1	—
6	32	14.2 ± 0.1	28.4 ± 0.1
8, 10	44	20.2 ± 0.1	40.4 ± 0.1

<Magazine packaging specifications>

- Packing quantities of magazines are different depending on the bit number of the switches. Please order the multiple numbers of the specific packing quantities. (e.g. 62 pcs., 124 pcs., 186 pcs., etc., in case of 2 bits version)

Pieces in package : 2 bits, 62 pcs./stick 3 bits, 46 pcs./stick
 4 bits, 36 pcs./stick 5 bits, 30 pcs./stick
 6 bits, 26 pcs./stick 8 bits, 20 pcs./stick
 10 bits, 16 pcs./stick