

Technical Data

TRANSISTOR

maximum ratings

VDS	40.0	V	NO.	2N4392
VDG	40.0	V	TYPE	N-FET
VGS	40.0	V		
ID	0.1	A		
IDM		A	CASE	TO-18
IG	0.05	A		
Max. Power Dissipation (PT) at TC = 25 °C	1.8	W		
Max. Thermal Resistance (Rth J-C)	100.0	°C/W		
Max. Junction Temperature (TJ)	200.0	°C		

PERFORMANCE CHARACTERISTICS at $T_c = 25^\circ\text{C}$, unless otherwise noted

NO.	SYMBOL	CONDITIONS	MIN.	MAX.	UNITS
1.	BVGSS	IG = 1.0 μA	40.0	-	V
2.	BVDGO	ID = 1.0 μA	40.0	-	V
3.	IGSS	VGS = 20.0 V	-	0.1	nA
4.	VGS(OFF)	VDS = 20.0 V, ID = 1.0 nA	2.0	5.0	V
5.	ID(OFF)	VDS = 20.0 V, VSG = 5.0 V	-	0.2	nA
6.	IDSS	VDS = 20.0 V	25.0	75.0	mA
7.	VDS(ON)	ID = 6.0 mA	-	0.4	V
8.	RDS(ON)	ID = 1.0 mA	-	60.0	Ω
9.	Ciss	VDS = 20.0 V	-	14.0	pF
10.	Crss	VGS = 7.0 V	-	3.5	pF
11.					
12.					
13.					
14.					
15.					
16.					
17.					
18.					
19.					
20.					

Notes

DIMENSIONS
in mm

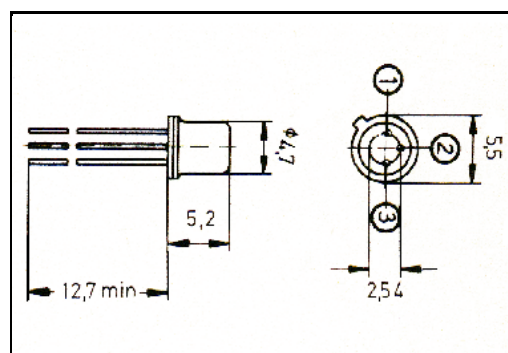

Marking 2N4392

Customer GENERAL PURPOSE