38 V 2 A synchronous step-down switching regulator with 30 μ A quiescent current

Datasheet - production data

**Features**

- 2 A DC output current
- 4 V to 38 V operating input voltage
- Low consumption mode or low noise mode
- 30 μ A IQ at light load (LCM $V_{OUT} = 3.3\text{ V}$)
- 8 μ A $I_{Q-SHTDWN}$
- Adjustable f_{SW} (250 kHz - 2 MHz)
- Output voltage adjustable from 0.85 V to V_{IN}
- Embedded output voltage supervisor
- Synchronization
- Adjustable soft-start time
- Internal current limiting
- Overvoltage protection
- Output voltage sequencing
- Peak current mode architecture
- $R_{DS(on)HS} = 180\text{ m}\Omega$, $R_{DS(on)LS} = 150\text{ m}\Omega$
- Thermal shutdown

Applications

- Designed for 12 V and 24 V buses
- Programmable logic controllers (PLCs)
- Decentralized intelligent nodes
- Sensors and low noise applications (LNM)

Description

The L6986 device is a step-down monolithic switching regulator able to deliver up to 2 A DC. The output voltage adjustability ranges from 0.85 V to V_{IN} . Thanks to the P-channel MOSFET high-side power element, the device features 100% duty cycle operation. The wide input voltage range meets the specification for the 5 V, 12 V and 24 V power supplies. The “Low Consumption Mode” (LCM) is designed for applications active during idle mode, so it maximizes the efficiency at light load with controlled output voltage ripple. The “Low Noise Mode” (LNM) makes the switching frequency constant overload current range, meeting the low noise application specification. The output voltage supervisor manages the reset phase for any digital load (μ C, FPGA, etc.). The RST open collector output can also implement output voltage sequencing during the power-up phase. The synchronous rectification, designed for high efficiency at medium - heavy load, and the high switching frequency capability make the size of the application compact. Pulse by pulse current sensing on both power elements implements an effective constant current protection.

Contents

- 1 Application schematic 4**

- 2 Pin settings 5**
 - 2.1 Pin connection 5
 - 2.2 Pin description 5
 - 2.3 Maximum ratings 6
 - 2.4 Thermal data 7
 - 2.5 ESD protection 7

- 3 Electrical characteristics 8**

- 4 Functional description 12**
 - 4.1 Power supply and voltage reference 13
 - Switchover feature 13
 - 4.2 Voltages monitor 13
 - 4.3 Soft-start and inhibit 14
 - 4.3.1 Ratiometric startup 19
 - 4.3.2 Output voltage sequencing 21
 - 4.4 Error amplifier 22
 - 4.5 Light load operation 22
 - 4.5.1 Low noise mode (LNM) 23
 - 4.5.2 Low consumption mode (LCM) 23
 - 4.6 Switchover feature 26
 - 4.6.1 LCM 26
 - 4.6.2 LNM 26
 - 4.7 Overcurrent protection 27
 - OCP and switchover feature 29
 - 4.8 Overvoltage protection 31
 - 4.9 Thermal shutdown 32

5	Closing the loop	33
5.1	$G_{CO}(s)$ control to output transfer function	33
5.2	Error amplifier compensation network	35
5.3	Voltage divider	36
5.4	Total loop gain	37
5.5	Compensation network design	39
6	Application notes	41
6.1	Output voltage adjustment	41
6.2	Switching frequency	41
6.3	MLF pin	41
6.4	Voltage supervisor	42
6.5	Synchronization (LNM)	43
6.6	Design of the power components	47
6.6.1	Input capacitor selection	47
6.6.2	Inductor selection	49
6.6.3	Output capacitor selection	50
7	Application board	51
8	Efficiency curves	55
9	Package information	62
10	Order codes	64
11	Revision history	65

1 Application schematic

Figure 1. Application schematic

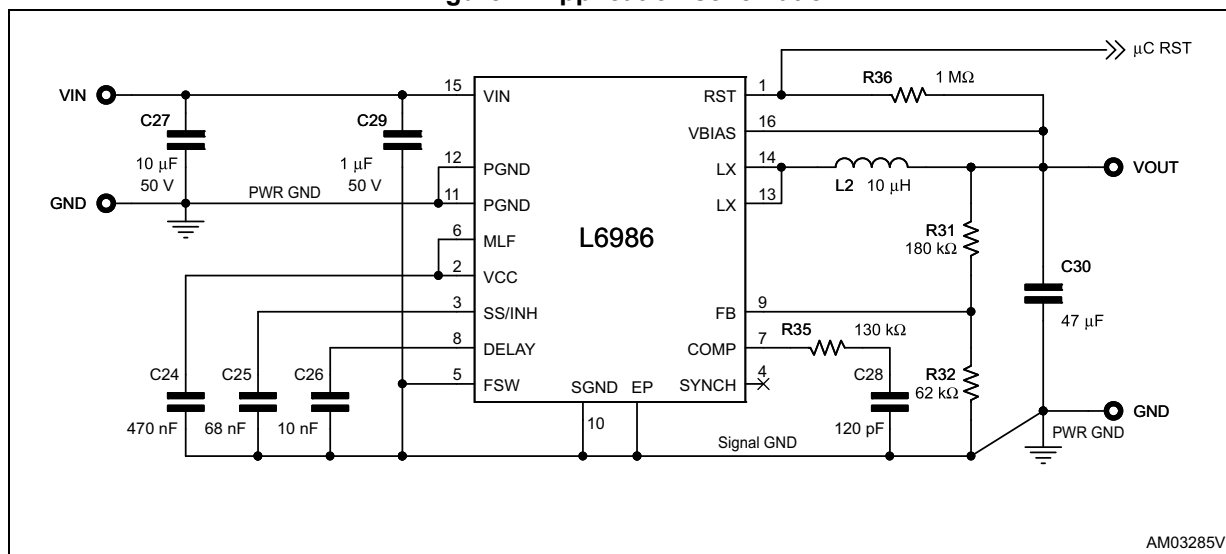

2 Pin settings

2.1 Pin connection

Figure 2. Pin connection (top view)

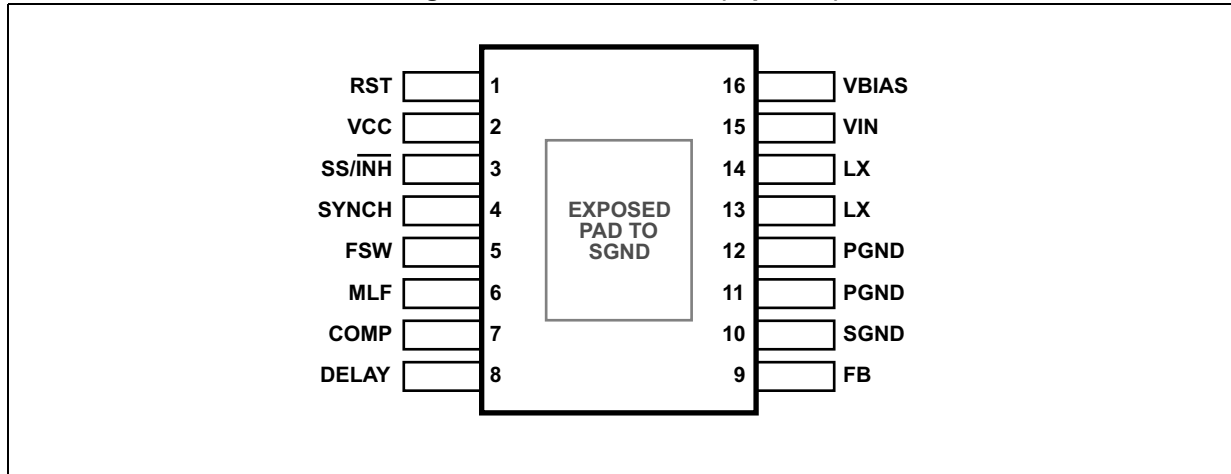

2.2 Pin description

Table 1. Pin description

No.	Pin	Description
1	RST	The RST open collector output is driven low when the output voltage is out of regulation. The RST is released after an adjustable time DELAY once the output voltage is over the active delay threshold.
2	VCC	Connect a ceramic capacitor (≥ 470 nF) to filter internal voltage reference. This pin supplies the embedded analog circuitry.
3	SS/ $\overline{\text{INH}}$	An open collector stage can disable the device clamping this pin to GND ($\overline{\text{INH}}$ mode). An internal current generator ($2 \mu\text{A typ.}$) charges the external capacitor to implement the soft-start.
4	SYNCH	Master / slave synchronization
5	FSW	A pull up resistor (E24 series only) to VCC or pull down to GND selects the switching frequency. Pinstrapping is active only before the soft-start phase to minimize the IC consumption.
6	MLF	A pull up resistor (E24 series only) to VCC or pull down to GND selects the low noise mode/low consumption mode and the active RST threshold. Pinstrapping is active only before the soft-start phase to minimize the IC consumption.
7	COMP	Output of the error amplifier. The designed compensation network is connected at this pin.
8	DELAY	An external capacitor connected at this pin sets the time DELAY to assert the rising edge of the RST o.c. after the output voltage is over the reset threshold. If this pin is left floating, RST is like a power good.
9	FB	Inverting input of the error amplifier
10	SGND	Signal GND
11	PGND	Power GND

Table 1. Pin description (continued)

No.	Pin	Description
12	PGND	Power GND
13	LX	Switching node
14	LX	Switching node
15	VIN	DC input voltage
16	V _{BIAS}	Typically connected to the regulated output voltage. An external voltage reference can be used to supply part of the analog circuitry to increase the efficiency at light load. Connect to GND if not used.
	E. p.	Exposed pad must be connected to SGND

2.3 Maximum ratings

Table 2. Absolute maximum ratings

Symbol	Description	Min.	Max.	Unit
V _{IN}	See Table 1	40	V	
DELAY		-0.3	V _{CC} + 0.3	V
PGND		SGND - 0.3	SGND + 0.3	V
SGND				V
V _{CC}		-0.3	(V _{IN} + 0.3) OR [max. 4]	V
SS / INH		-0.3	V _{IN} + 0.3	V
MLF		-0.3	V _{CC} + 0.3	V
COMP		-0.3	V _{CC} + 0.3	V
FB		-0.3	V _{CC} + 0.3	V
FSW		-0.3	V _{CC} + 0.3	V
SYNCH		-0.3	V _{IN} + 0.3	V
V _{BIAS}		-0.3	(V _{IN} + 0.3) OR [max. 6]	V
RST		-0.3	V _{IN} + 0.3	V
LX		-0.3	V _{IN} + 0.3	V
T _J	Operating temperature range	-40	150	°C
T _{STG}	Storage temperature range		-65 to 150	°C
T _{LEAD}	Lead temperature (soldering 10 sec.)		260	°C
I _{HS} , I _{LS}	High-side / low-side switch current		2	A

2.4 Thermal data

Table 3. Thermal data

Symbol	Parameter	Value	Unit
R_{thJA}	Thermal resistance junction ambient (device soldered on the STMicroelectronics® demonstration board)	40	C/W

2.5 ESD protection

Table 4. ESD protection

Symbol	Test condition	Value	Unit
ESD	HBM	2	KV
	MM	200	V
	CDM	500	V

3 Electrical characteristics

$T_J = 25\text{ }^\circ\text{C}$, $V_{IN} = 12\text{ V}$ unless otherwise specified.

Table 5. Electrical characteristics

Symbol	Parameter	Test condition	Note	Min.	Typ.	Max.	Unit
V_{IN}	Operating input voltage range			4		38	V
V_{INH}	V_{CC} UVLO rising threshold			2.7		3.5	
V_{IN}	Operating input voltage range			4		38	V
V_{INH}	V_{CC} UVLO rising threshold			2.7		3.5	
V_{INL}	V_{CC} UVLO falling threshold			2.5		3.5	
I_{PK}	Peak current limit	Duty cycle < 40%		2.6			A
		Duty cycle = 100% closed loop operation		2.1			
I_{VY}	Valley current limit			2.7			
I_{SKIP}	Skip current limit		(1)		0.6	0.8	
I_{VY_SNK}	Reverse current limit	LNM or V_{OUT} overvoltage		0.5	1	2	
$R_{DSON\ HS}$	High-side RDSON	$I_{SW} = 1\text{ A}$			0.18	0.360	Ω
$R_{DSON\ LS}$	Low-side RDSON	$I_{SW} = 1\text{ A}$			0.15	0.300	
f_{SW}	Selected switching frequency	FSW pinstrapping before SS		see Table 6: f_{SW} selection			
I_{FSW}	FSW biasing current	SS ended			0	500	nA
LCM/LNM	Low noise mode / Low consumption mode selection	MLF pinstrapping before SS		see Table 7: LNM / LCM selection on page 11			
I_{MLF}	MLF biasing current	SS ended			0	500	nA
D	Duty cycle		(2)	0		100	%
$T_{ON\ MIN}$	Minimum On time				100		ns
VCC regulator							
V_{CC}	LDO output voltage	$V_{BIAS} = \text{GND}$ (no switchover)		2.9	3.3	3.6	V
		$V_{BIAS} = 5\text{ V}$ (switchover)		2.9	3.3	3.6	
SWO	V_{BIAS} threshold	Switch internal supply from V_{IN} to V_{BIAS}		2.85		3.2	
		Switch internal supply from V_{BIAS} to V_{IN}		2.8		3.15	
Power consumption							
I_{SHTDWN}	Shutdown current from V_{IN}	$V_{SS/INH} = \text{GND}$		4	8	15	μA

Table 5. Electrical characteristics (continued)

Symbol	Parameter	Test condition	Note	Min.	Typ.	Max.	Unit
$I_{Q\ OPVIN}$	Quiescent current from V_{IN}	LCM - SWO $V_{REF} < V_{FB} < V_{OVP}$ (SLEEP) $V_{BIAS} = 3.3\text{ V}$	(3)	4	10	15	μA
		LCM - NO SWO $V_{REF} < V_{FB} < V_{OVP}$ (SLEEP) $V_{BIAS} = \text{GND}$	(3)	45	70	100	
		LNM - SWO $V_{FB} = \text{GND}$ (NO SLEEP) $V_{BIAS} = 3.3\text{ V}$		0.5	1.5	5	mA
		LNM - NO SWO $V_{FB} = \text{GND}$ (NO SLEEP) $V_{BIAS} = \text{GND}$		2	2.8	6	
$I_{Q\ OPVBIAS}$	Quiescent current from V_{BIAS}	LCM - SWO $V_{REF} < V_{FB} < V_{OVP}$ (SLEEP) $V_{BIAS} = 3.3\text{ V}$	(3)	30	50	90	μA
		LNM - SWO $V_{FB} = \text{GND}$ (NO SLEEP) $V_{BIAS} = 3.3\text{ V}$		0.5	1.2	5	mA
Soft-start							
V_{INH}	VSS threshold	SS rising		200	460	700	mV
$V_{INH\ HYST}$	VSS hysteresis				60		
$I_{SS\ CH}$	C_{SS} charging current	$V_{SS} < V_{INH}$ OR $t < T_{SS\ SETUP}$ OR $V_{EA+} > V_{FB}$	(2)		1		μA
		$t > T_{SS\ SETUP}$ AND $V_{EA+} < V_{FB}$	(2)		4		
$V_{SS\ CLMP}$	SS discharge voltage	$V_{CC} < V_{CCH}$ OR $t < T_{SS\ SETUP}$ OR thermal fail		855	900	945	mV
$V_{SS\ START}$	Start of internal error amplifier ramp			0.995	1.1	1.150	V
SS_{GAIN}	SS/INH to internal error amplifier gain				3		
$V_{SS\ END}$	SS/INH voltage at the end of SS phase				2.5	3.6	V
Error amplifier							
V_{FB}	Voltage feedback			0.841	0.85	0.859	V
I_{FB}	FB biasing current				50	500	nA
G_m	Transconductance			85	155	210	μS
A_v	Error amplifier gain		(2)		100		dB

Table 5. Electrical characteristics (continued)

Symbol	Parameter	Test condition	Note	Min.	Typ.	Max.	Unit
I_{COMP}	EA output current capability			±6	±12	±25	µA
Inner current loop							
g_{CS}	Current sense transconductance (V_{COMP} to inductor current gain)	$I_{pk} = 1\text{ A}$	(4)		2.5		A/V
$V_{PP} \cdot g_{CS}$	Slope compensation		(4)	0.4	0.75	1.0	A
Overvoltage protection							
V_{OVP}	Overvoltage trip (V_{OVP}/V_{REF})			1.15	1.2	1.25	
$V_{OVP\ HYST}$	Overvoltage hysteresis			0.5	2	5	%
Synchronization (fan out: 6 slave devices typ.)							
$f_{SYN\ MIN}$	Synchronization frequency	LNM; $f_{SW} = VCC$		266.5			kHz
$V_{SYN\ TH}$	SYNCH input threshold	LNM, SYNCH rising		0.70		1.2	V
$V_{SYN\ HYST}$	SYNCH input threshold hysteresis	LNM			20		mV
I_{SYN}	SYNCH pulldown current	LNM, $V_{SYN} = 1.2\text{ V}$			0.7		mA
$V_{SYN\ OUT}$	high level output	LNM, 5 mA sinking load		1.40			V
	low level output	LNM, 0.7 mA sourcing load				0.6	
Reset							
V_{THR}	Selected RST threshold	MLF pinstrapping before SS		see Table 7: LNM / LCM selection			
$V_{THR\ HYST}$	RST hysteresis		(2)		2		%
V_{RST}	RST open collector output	$V_{IN} > V_{INH}$ AND $V_{FB} < V_{TH}$ 4 mA sinking load				0.4	V
		$2 < V_{IN} < V_{INH}$ 4 mA sinking load				0.8	
Delay							
V_{THD}	RST open collector released as soon as $V_{DELAY} > V_{THD}$	$V_{FB} > V_{THR}$		1.19	1.234	1.258	V
$I_{D\ CH}$	C_{DELAY} charging current	$V_{FB} > V_{THR}$		1	2	3	µA
Thermal shutdown							
T_{SHDWN}	Thermal shutdown temperature		(2)		165		°C
T_{HYS}	Thermal shutdown hysteresis		(2)		30		

1. Parameter tested in static condition during testing phase. Parameter value may change over dynamic application condition.
2. Not tested in production.
3. LCM enables SLEEP mode at light load.
4. Measured at $f_{SW} = 250\text{ kHz}$.

All the population tested at $T_J = 25\text{ }^\circ\text{C}$, $V_{IN} = 12\text{ V}$ unless otherwise specified.

Table 6. f_{SW} selection

Symbol	R_{VCC} (E24 series)	R_{GND} (E24 series)	f_{SW} min.	f_{SW} typ.	f_{SW} max.	Note	Unit
f_{SW}	0 Ω	NC	225	250	275	(1)	kHz
	1.8 k Ω	NC		285		(2)	
	3.3 k Ω	NC		330			
	5.6 k Ω	NC		380			
	10 k Ω	NC		435		(1)	
	NC	0 Ω	450	500	550		
	18 k Ω	NC		575			
	33 k Ω	NC		660		(2)	
	56 k Ω	NC		755			
	NC	1.8 k Ω		870			
	NC	3.3 k Ω	900	1000	1100	(2)	
	NC	5.6 k Ω		1150			
	NC	10 k Ω		1310			
	NC	18 k Ω		1500		(2)	
	NC	33 k Ω	1575	1750	1925		
	NC	56 k Ω	1800	2000	2200		

1. Preferred codifications don't require any external resistor.
2. Not tested in production.

All the population tested at $T_J = 25\text{ }^\circ\text{C}$, $V_{IN} = 12\text{ V}$ unless otherwise specified.

Table 7. LNM / LCM selection

Symbol	R_{VCC} (E24 series)	R_{GND} (E24 series)	Operating mode	V_{RST}/V_{OUT} (tgt value)	V_{RST} min.	V_{RST} typ.	V_{RST} max.	Unit
V_{RST}	0 Ω	NC	LCM	93%	0.779	0.791	0.802	V
	8.2 k $\Omega \pm 1\%$	NC		80%	0.670	0.680	0.690	
	18 k $\Omega \pm 1\%$	NC		87%	0.728	0.740	0.751	
	39 k $\Omega \pm 1\%$	NC		96%	0.804	0.816	0.828	
	NC	0 Ω	LNM	93%	0.779	0.791	0.802	
	NC	8.2 k $\Omega \pm 1\%$		80%	0.670	0.680	0.690	
	NC	18 k $\Omega \pm 1\%$		87%	0.728	0.740	0.751	
	NC	39 k $\Omega \pm 1\%$		96%	0.804	0.816	0.828	

$V_{RST} = 0.791\text{ V}$ typical, LNM and LCM preferred codifications don't require any external resistor.

4 Functional description

The L6986 device is based on a “peak current mode”, constant frequency control. As a consequence, the intersection between the error amplifier output and the sensed inductor current generates the PWM control signal to drive the power switch.

The device features LNM (low noise mode) that is forced PWM control, or LCM (low consumption mode) to increase the efficiency at light load.

The main internal blocks shown in the block diagram in [Figure 3](#) are:

- Embedded power elements. Thanks to the P-channel MOSFET as high-side switch the device features low dropout operation
- A fully integrated sawtooth oscillator with adjustable frequency
- A transconductance error amplifier
- The high-side current sense amplifier to sense the inductor current
- A “Pulse Width Modulator” (PWM) comparator and the driving circuitry of the embedded power elements
- The soft-start blocks to ramp the error amplifier reference voltage and so decreases the inrush current at power-up. The SS/ $\overline{\text{INH}}$ pin inhibits the device when driven low.
- The switchover capability of the internal regulator to supply a portion of the quiescent current when the V_{BIAS} pin is connected to an external output voltage
- The synchronization circuitry to manage master / slave operation and the synchronization to an external clock
- The current limitation circuit to implement the constant current protection, sensing pulse by pulse high-side / low-side switch current. In case of heavy short-circuit the current protection is fold back to decrease the stress of the external components
- A circuit to implement the thermal protection function
- The OVP circuitry to discharge the output capacitor in case of overvoltage event
- MLF pin strapping sets the LNM/LCM mode and the thresholds of the RST comparator
- FSW pinstrapping sets the switching frequency
- The RST open collector output

Figure 3. Internal block diagram

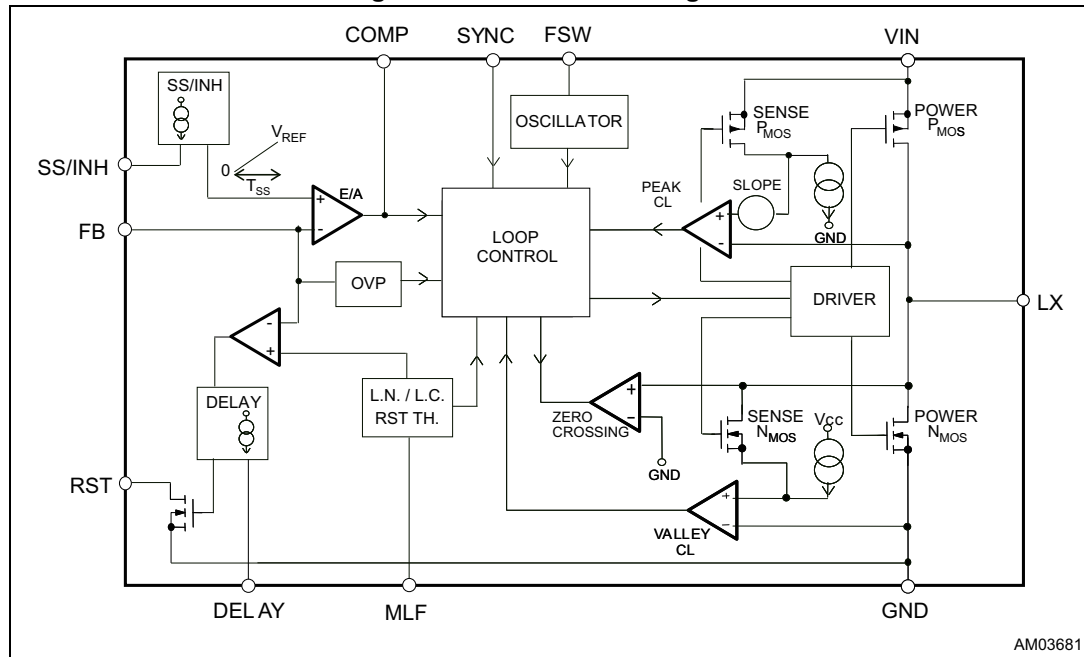

4.1 Power supply and voltage reference

The internal regulator block consists of a start-up circuit, the voltage pre-regulator that provides current to all the blocks and the bandgap voltage reference. The starter supplies the startup current when the input voltage goes high and the device is enabled (SS/INH pin over the inhibits threshold).

The pre-regulator block supplies the bandgap cell and the rest of the circuitry with a regulated voltage that has a very low supply voltage noise sensitivity.

Switchover feature

The switchover scheme of the pre-regulator block features to derive the main contribution of the supply current for the internal circuitry from an external voltage ($3\text{ V} < V_{\text{BIAS}} < 5.5\text{ V}$ is typically connected to the regulated output voltage). This helps to decrease the equivalent quiescent current seen at V_{IN} . (please refer to [Section 4.6: Switchover feature on page 26](#)).

4.2 Voltages monitor

An internal block continuously senses the V_{CC} , V_{BIAS} and V_{BG} . If the monitored voltages are good, the regulator starts operating. There is also a hysteresis on the V_{CC} (UVLO).

Figure 4. Internal circuit

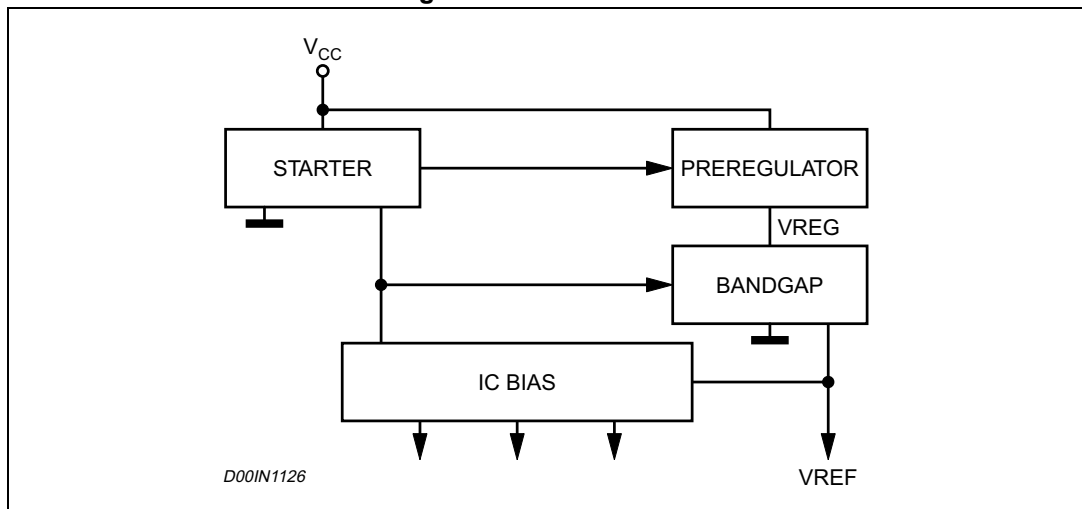

4.3 Soft-start and inhibit

The soft-start and inhibit features are multiplexed on the same pin. An internal current source charges the external soft-start capacitor to implement a voltage ramp on the SS/INH pin. The device is inhibited as long as the SS/INH pin voltage is lower than the V_{INH} threshold and the soft-start takes place when SS/INH pin crosses $V_{SS\ START}$. (see [Figure 5: Soft-start phase](#)).

The internal current generator sources 1 μA typ. current when the voltage of the VCC pin crosses the UVLO threshold. The current increases to 4 μA typ. as soon as the SS/INH voltage is higher than the V_{INH} threshold. This feature helps to decrease the current consumption in inhibit mode. An external open collector can be used to set the inhibit operation clamping the SS/INH voltage below V_{INH} threshold.

The startup feature minimizes the inrush current and decreases the stress of the power components during the power-up phase. The ramp implemented on the reference of the error amplifier has a gain three times higher (SS_{GAIN}) than the external ramp present at SS/INH pin.

Figure 5. Soft-start phase

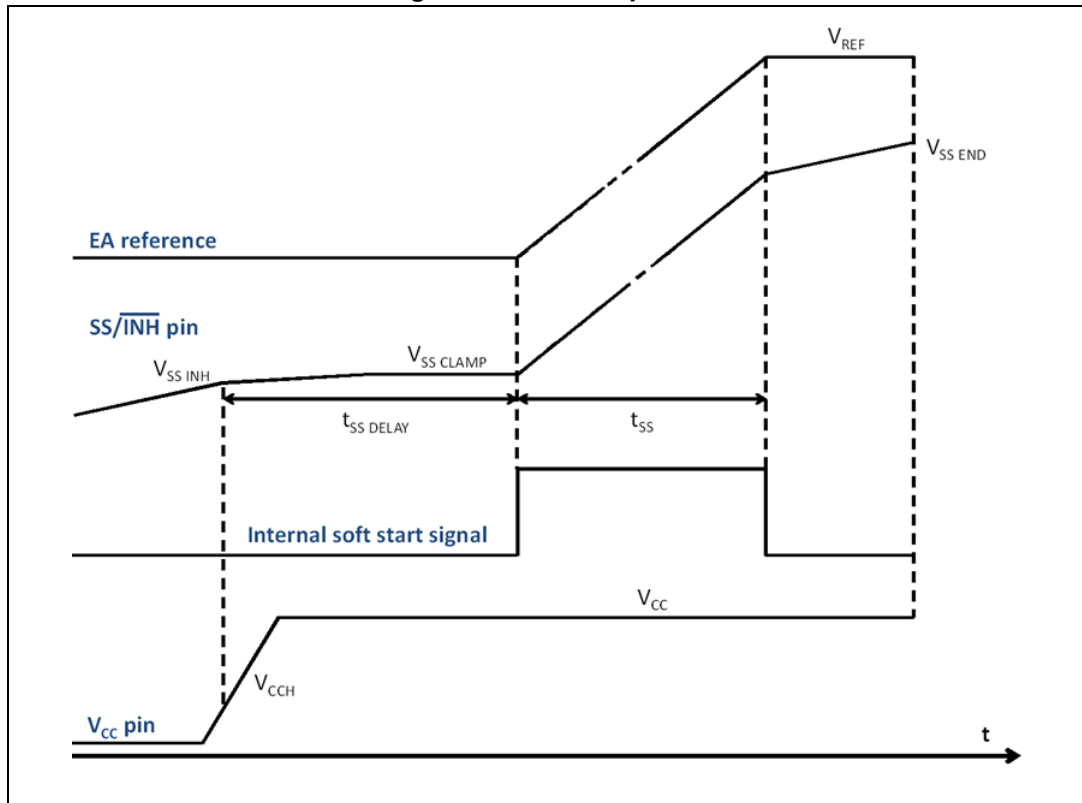

The C_{SS} is dimensioned accordingly with [Equation 1](#):

Equation 1

$$C_{SS} = SS_{GAIN} \cdot \frac{I_{SSCH} \cdot T_{SS}}{V_{FB}} = 3 \cdot \frac{4\mu A \cdot T_{SS}}{0.85V}$$

where T_{SS} is the soft-start time, I_{SSCH} the charging current and V_{FB} the reference of the error amplifier.

The soft-start block supports the precharged output capacitor.

Figure 6. Soft-start phase with precharged C_{OUT}

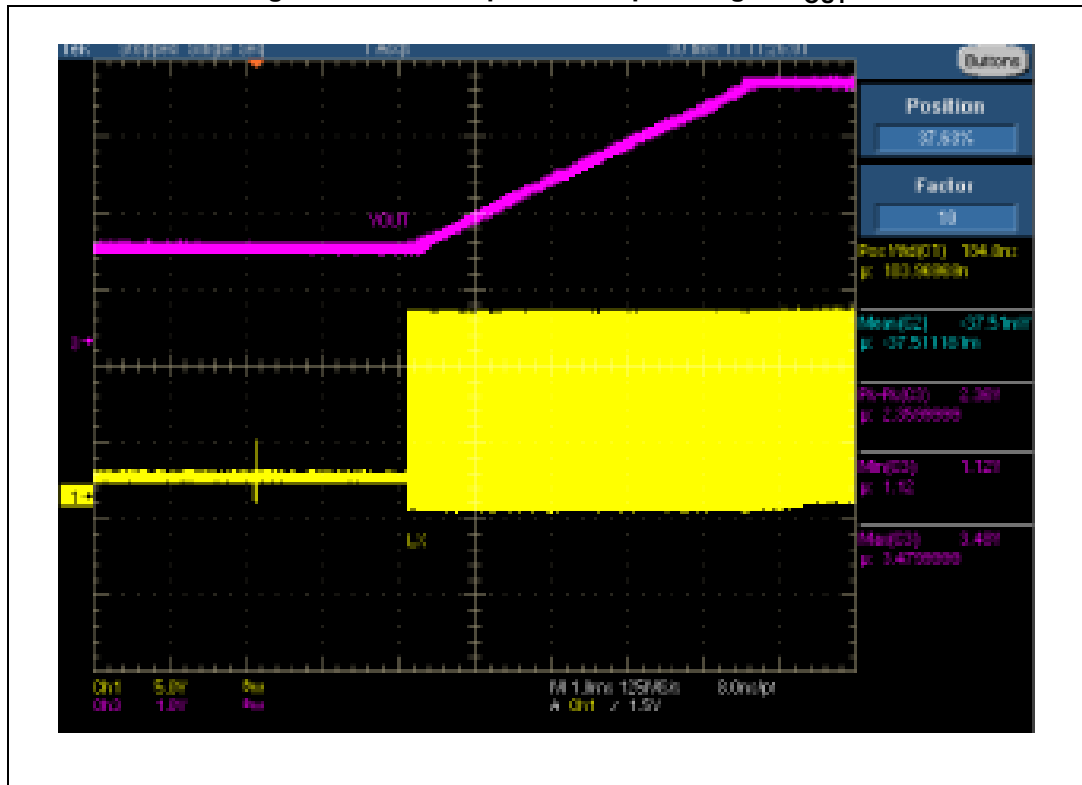

During normal operation a new soft-start cycle takes place in case of:

- Thermal shutdown event
- UVLO event
- The device is driven in $\overline{\text{INH}}$ mode

The soft-start capacitor is discharged with a 0.6 mA typ. current capability for 1 msec time max. For complete and proper capacitor discharge in case of fault condition, a maximum C_{SS} = 67 nF value is suggested.

The application example in [Figure 7](#) shows how to enable the L6986 and perform the soft-start phase driven by an external voltage step, for example the signal from the ignition switch in automotive applications.

Figure 7. Enable the device with external voltage step

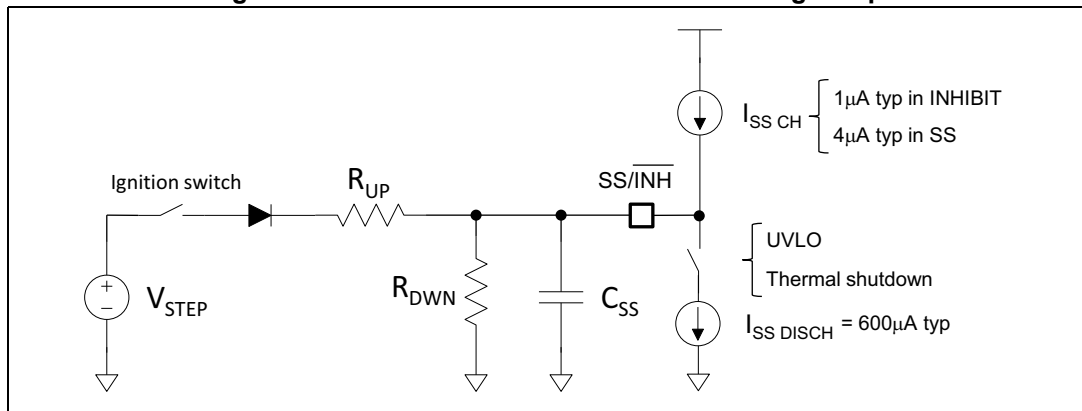

The maximum capacitor value has to be limited to guarantee the device can discharge it in case of thermal shutdown and UVLO events (see [Figure 9](#)), so restart the switching activity ramping the error amplifier reference voltage.

Equation 2

$$C_{SS} < \frac{-1 \text{ msec}}{R_{SS_EQ} \cdot \ln\left(1 - \frac{V_{SS_FINAL} - 0.9 \text{ V}}{600 \mu\text{A} \cdot R_{SS_EQ}}\right)}$$

where:

Equation 3

$$R_{SS_EQ} = \frac{R_{UP} \cdot R_{DWN}}{R_{UP} + R_{DWN}} \quad V_{SS_FINAL} = (V_{STEP} - V_{DIODE}) \cdot \frac{R_{DWN}}{R_{UP} + R_{DWN}}$$

The optional diode prevents to disable the device if the external source drops to ground.

R_{UP} value is selected in order to make the capacitor charge at first approximation independent from the internal current generator (4 μA typ. current capability, see [Table 5 on page 8](#)), so:

Equation 4

$$\frac{V_{STEP} - V_{DIODE} - V_{SS_END}}{R_{UP}} \gg I_{SS_CHARGE} \equiv 4 \mu\text{A}$$

where:

Equation 5

$$V_{SS_END} = V_{SS_START} + \frac{V_{FB}}{SS_{GAIN}}$$

represents the $\overline{SS/INH}$ voltage correspondent to the end of the ramp on the error amplifier (see [Figure 5](#)); refer to [Table 5](#) for V_{SS_START} , V_{FB} and SS_{GAIN} parameters.

As a consequence the voltage across the soft-start capacitor can be written as:

Equation 6

$$v_{SS}(t) = V_{SS_FINAL} \cdot \frac{1}{1 - e^{-\frac{t}{C_{SS} \cdot R_{SS_EQ}}}}$$

R_{SS_DOWN} is selected to guarantee the device stays in inhibit mode when the internal generator sources 1 μA typ. out of the $\overline{SS/INH}$ pin and V_{STEP} is not present:

Equation 7

$$R_{DWN} \cdot I_{SS_INHIBIT} \equiv R_{DWN} \cdot 1 \mu\text{A} \ll V_{INH} \equiv 200 \text{ mV}$$

so:

Equation 8

$$R_{DWN} < 100 \text{ k}\Omega$$

R_{UP} and R_{DWN} are selected to guarantee:

Equation 9

$$V_{SS_FINAL} \cong 2 V > V_{SS_END}$$

The time to ramp the internal voltage reference can be calculated from *Equation 10*:

Equation 10

$$T_{SS} = C_{SS} \cdot R_{SS_EQ} \cdot \ln\left(\frac{V_{SS_FINAL} - V_{SS_START}}{V_{SS_FINAL} - V_{SS_END}}\right)$$

that is the equivalent soft-start time to ramp the output voltage.

Figure 8 shows the soft-start phase with the following component selection: $R_{UP} = 180 \text{ k}\Omega$, $R_{DWN} = 33 \text{ k}\Omega$, $C_{SS} = 200 \text{ nF}$, the 1N4148 is a small signal diode and $V_{STEP} = 13 \text{ V}$.

Figure 8. External soft-start network V_{STEP} driven

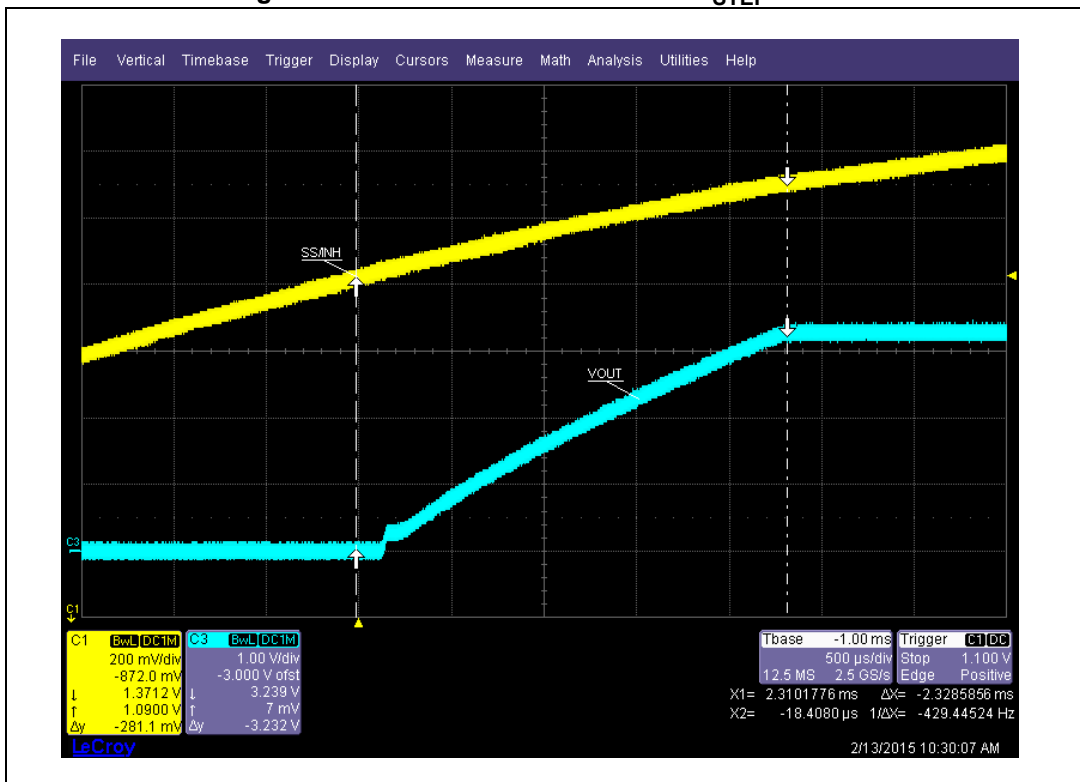

The circuit in *Figure 7* introduces a time delay between V_{STEP} and the switching activity that can be calculated as:

Equation 11

$$T_{SS\ DELAY} = C_{SS} \cdot R_{SS_EQ} \cdot \ln\left(\frac{V_{SS_FINAL}}{V_{SS_FINAL} - V_{SS_START}}\right)$$

Figure 9 shows how the device discharges the soft-start capacitor after an UVLO or thermal shutdown event in order to restart the switching activity ramping the error amplifier reference voltage.

Figure 9. External soft-start after UVLO or thermal shutdown

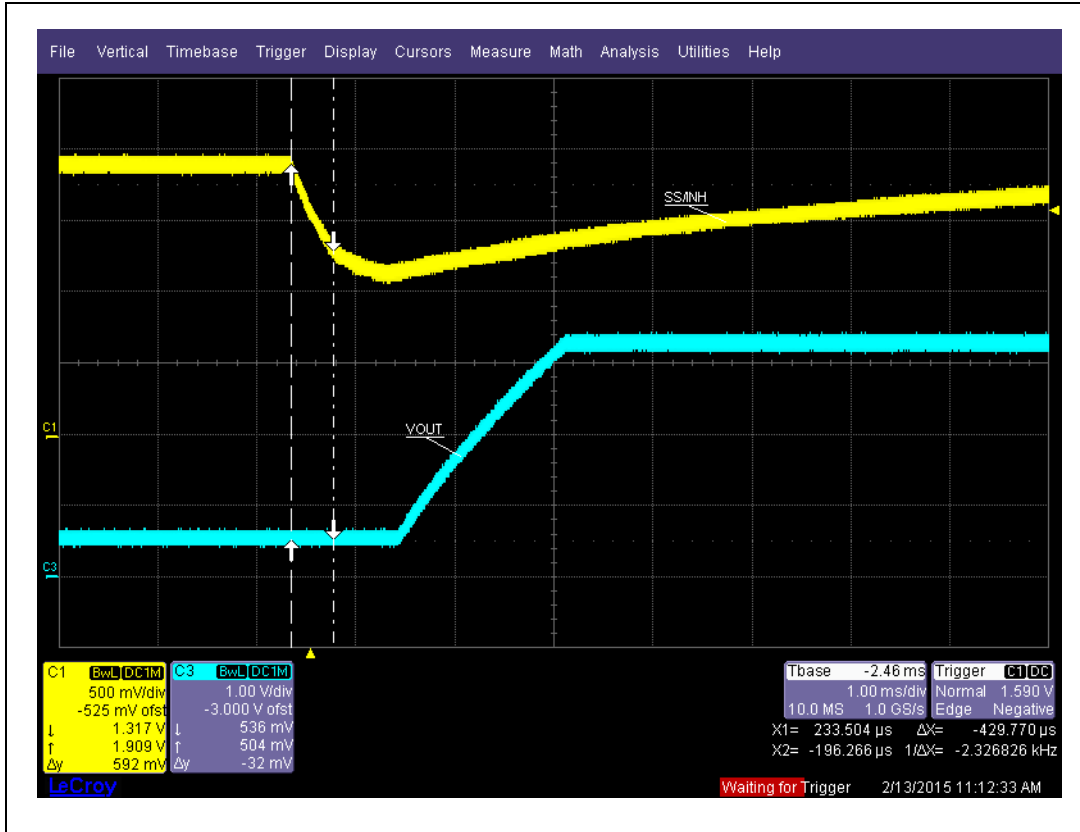

4.3.1 Ratiometric startup

The ratiometric startup is implemented sharing the same soft-start capacitor for a set of the L6986 device.

Figure 10. Ratiometric startup

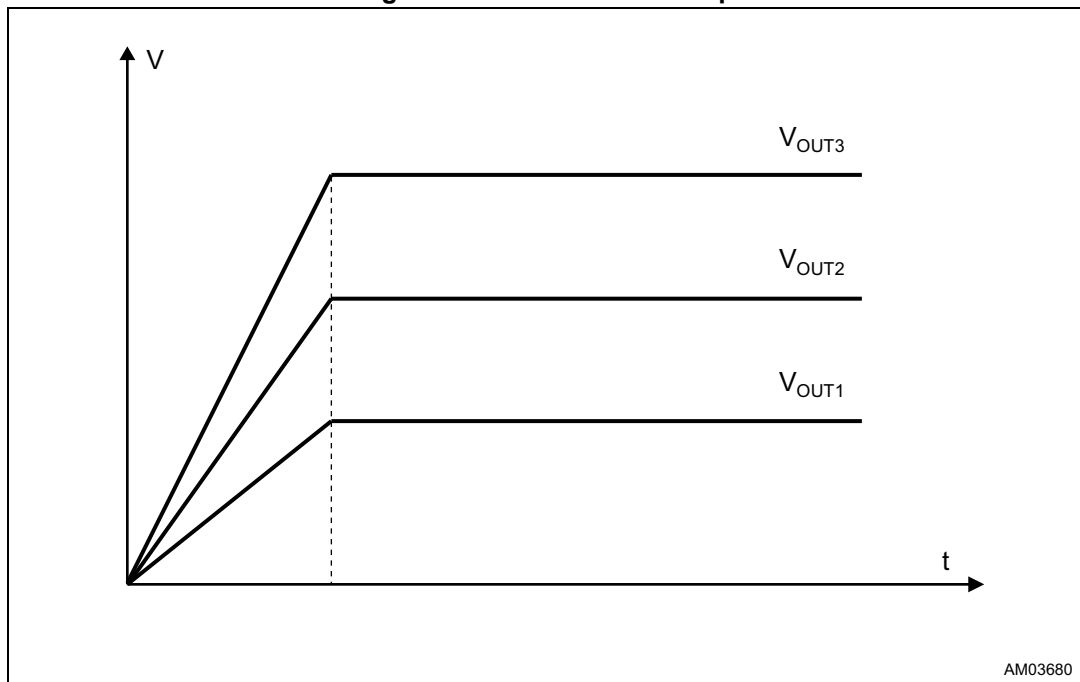

As a consequence all the internal current generators charge in parallel the external capacitor. The capacitor value is dimensioned accordingly with [Equation 12](#):

Equation 12

$$C_{SS} = n_{L6986} \cdot SS_{GAIN} \cdot \frac{I_{SSCH} \cdot T_{SS}}{V_{FB}} = n_{L6986} \cdot 3 \cdot \frac{4\mu A \cdot T_{SS}}{0.85V}$$

where n_{L6986} represents the number of devices connected in parallel.

For better tracking of the different output voltages the synchronization of the set of regulators is suggested.

Figure 11. Ratiometric startup operation

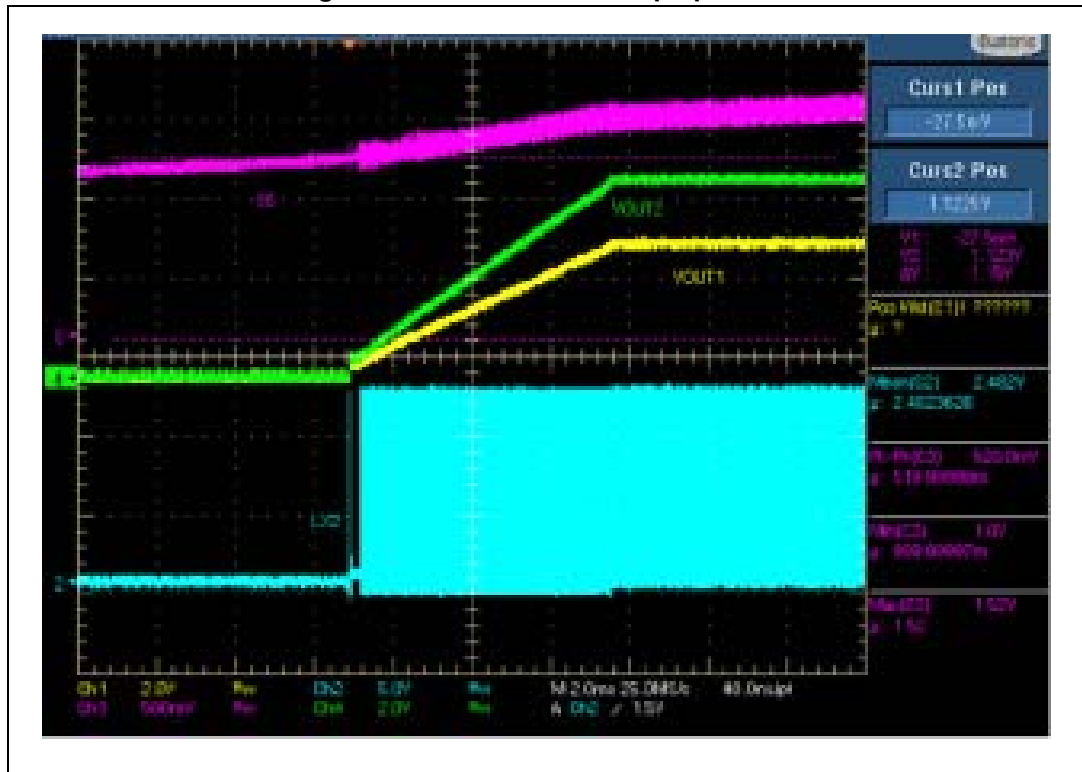

4.3.2 Output voltage sequencing

The L6986 device implements sequencing connecting the RST pin of the master device to the SS/INH of the slave. The slave is inhibited as long as the master output voltage is outside regulation so implementing the sequencing (see [Figure 12](#)).

Figure 12. Output voltage sequencing

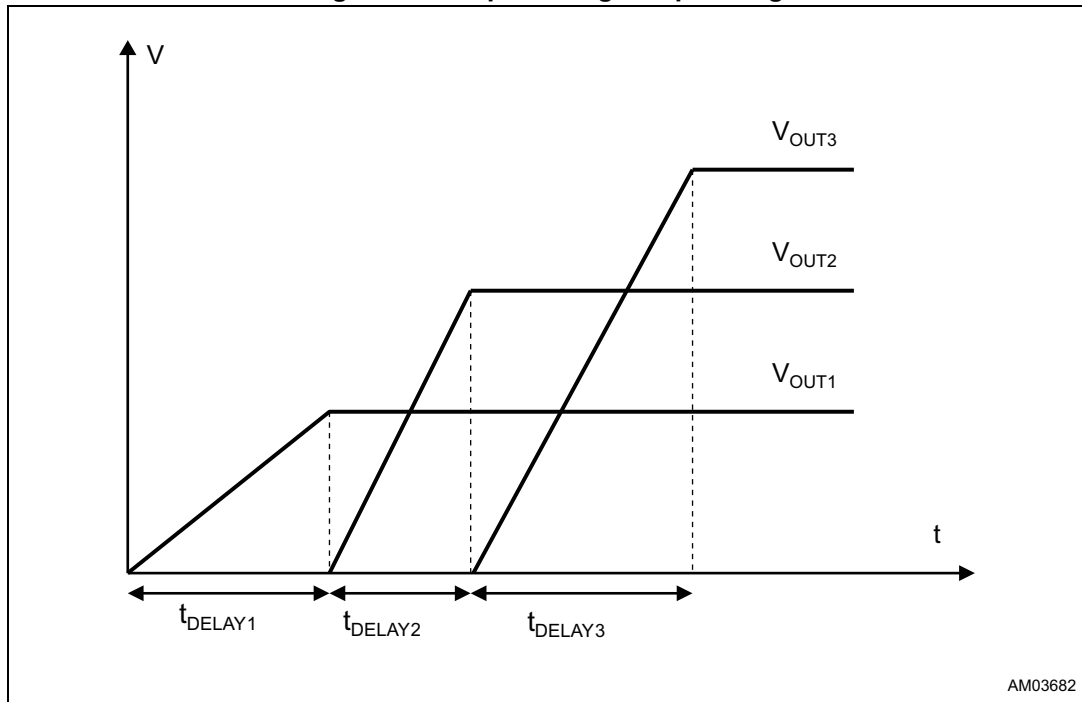

High flexibility is achieved thanks to the programmable RST thresholds (see [Table 7: LNM / LCM selection on page 11](#)) and programmable delay time. To minimize the component count the DELAY pin capacitor can be also omitted so the pin works as a normal power good.

4.4 Error amplifier

The voltage error amplifier is the core of the loop regulation. It is a transconductance operational amplifier whose non inverting input is connected to the internal voltage reference (0.85 V), while the inverting input (FB) is connected to the external divider or directly to the output voltage.

Table 8. Uncompensated error amplifier characteristics

Description	Values
Transconductance	155 μ S
Low frequency gain	100 dB

The error amplifier output is compared with the inductor current sense information to perform PWM control. The error amplifier also determines the burst operation at light load when the LCM is active.

4.5 Light load operation

The MLF pinstrapping during the power-up phase determines the light load operation (refer to [Table 7: LNM / LCM selection](#)).

4.5.1 Low noise mode (LNM)

The low noise mode implements a forced PWM operation over the different loading conditions. The LNM features a constant switching frequency to minimize the noise in the final application and a constant voltage ripple at fixed V_{IN} . The regulator in steady loading condition never skip pulses and it operates in continuous conduction mode (CCM) over the different loading conditions.

Figure 13. Low noise mode operation



Typical applications for the LNM operation are car audio, sensors.

4.5.2 Low consumption mode (LCM)

The low consumption mode maximizes the efficiency at light load. The regulator prevents the switching activity whenever the switch peak current request is lower than the I_{SKIP} threshold (700 mA typical). As a consequence the L6986 device works in bursts and it minimizes the quiescent current request in the meantime between the switching operation.

Figure 14. LCM operation at zero load



Given the energy stored in the inductor during a burst, the voltage ripple depends on the capacitor value:

Equation 13

$$V_{OUT\ RIPPLE} = \frac{\Delta Q_{IL}}{C_{OUT}} = \frac{\int_0^{T_{BURST}} (i_L(t) \cdot dt)}{C_{OUT}}$$

Figure 15. LCM operation over loading condition (part 1)



Figure 16. LCM operation over loading condition (part 2)



Figure 17. The regulator works in CCM

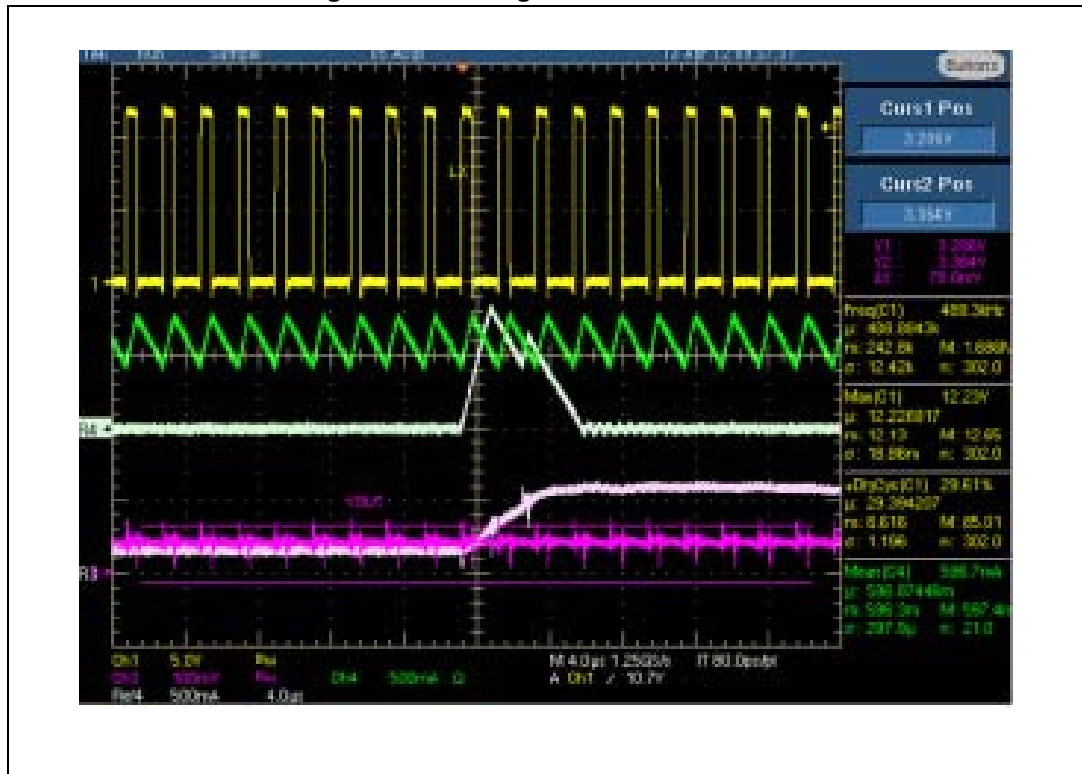

4.6 Switchover feature

The switchover maximizes the efficiency at light load that is crucial for LCM applications.

4.6.1 LCM

The LCM operation satisfies the high efficiency requirements of the battery powered applications. In order to minimize the regulator quiescent current request from the input voltage, the V_{BIAS} pin can be connected to an external voltage source in the range $3\text{ V} < V_{BIAS} < 5.5\text{ V}$ (see [Section 4.1: Power supply and voltage reference on page 13](#)).

In case the V_{BIAS} pin is connected to the regulated output voltage (V_{OUT}), the total current drawn from the input voltage can be calculated as:

Equation 14

$$I_{QVIN} = I_{QOPVIN} + \frac{1}{\eta_{L6986}} \cdot \frac{V_{BIAS}}{V_{IN}} \cdot I_{QOPVBIAS}$$

where I_{QOPVIN} , $I_{QOPVBIAS}$ are defined in [Table 5: Electrical characteristics on page 8](#) and η_{L6986} is the efficiency of the conversion in the working point.

4.6.2 LNM

[Equation 14](#) is also valid when the device works in LNM and it can increase the efficiency at medium load since the regulator always operates in continuous conduction mode.

4.7 Overcurrent protection

The current protection circuitry features a constant current protection, so the device limits the maximum peak current (see [Table 5: Electrical characteristics on page 8](#)) in overcurrent condition.

The L6986 device implements a pulse by pulse current sensing on both power elements (high-side and low-side switches) for effective current protection over the duty cycle range. The high-side current sensing is called “peak” the low-side sensing “valley”.

The internal noise generated during the switching activity makes the current sensing circuitry ineffective for a minimum conduction time of the power element. This time is called “masking time” because the information from the analog circuitry is masked by the logic to prevent an erroneous detection of the overcurrent event. As a consequence, the peak current protection is disabled for a masking time after the high-side switch is turned on, the valley for a masking time after the low-side switch is turned on. In other words, the peak current protection can be ineffective at extremely low duty cycles, the valley current protection at extremely high duty cycles.

The L6986 device assures an effective overcurrent protection sensing the current flowing in both power elements. In case one of the two current sensing circuitry is ineffective because of the masking time, the device is protected sensing the current on the opposite switch. Thus, the combination of the “peak” and “valley” current limits assure the effectiveness of the overcurrent protection even in extreme duty cycle conditions.

The valley current threshold is designed higher than the peak to guarantee a proper operation. In case the current diverges because of the high-side masking time, the low-side power element is turned on until the switch current level drops below the valley current sense threshold. The low-side operation is able to prevent the high-side turn on, so the device can skip pulses decreasing the swathing frequency.

Figure 18. Valley current sense operation in overcurrent condition

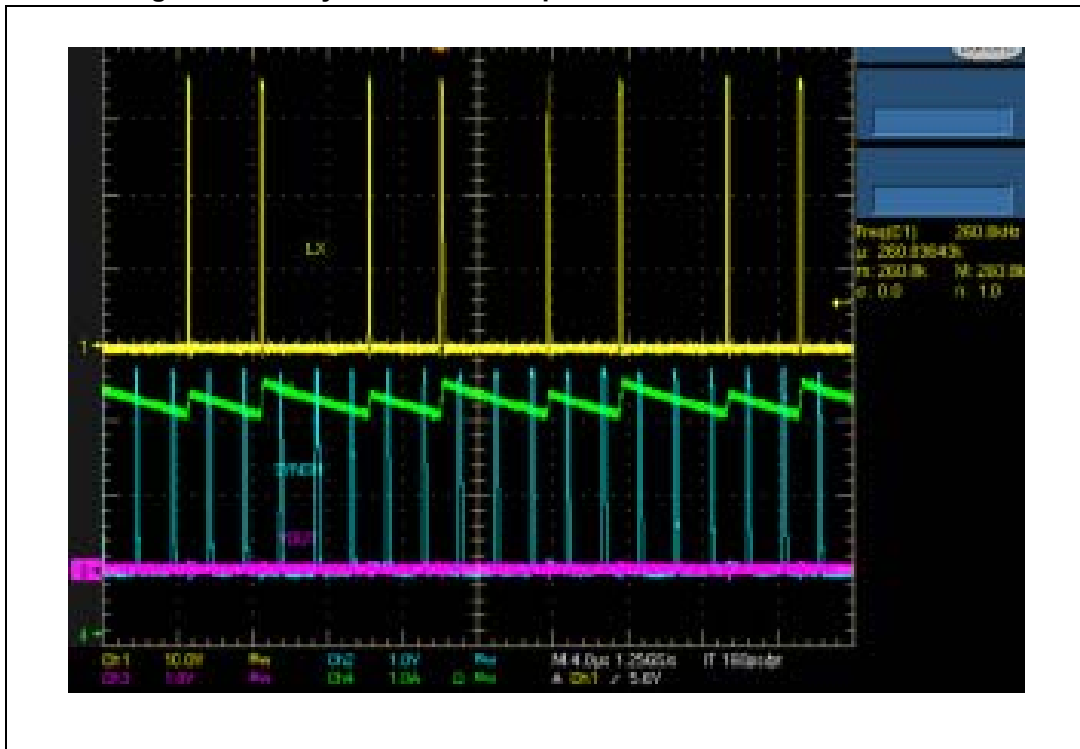

Figure 18 shows the switching frequency reduction during the valley current sense operation in case of extremely low duty cycle (V_{IN} 38 V, f_{SW} = 500 kHz short-circuit condition).

In worst case scenario (like Figure 18) of the overcurrent protection the switch current is limited to:

Equation 15

$$I_{MAX} = I_{VALLEY_TH} + \frac{V_{IN} - V_{OUT}}{L} \cdot T_{MASK_HS}$$

where I_{VALLEY_TH} is the current threshold of the valley sensing circuitry (see Table 5: Electrical characteristics on page 8) and T_{MASK_HS} is the masking time of the high-side switch 100 nsec. typ.).

In most of the overcurrent conditions the conduction time of the high-side switch is higher than the masking time and so the peak current protection limits the switch current.

Equation 16

$$I_{MAX} = I_{PEAK_TH}$$

Figure 19. Peak current sense operation in overcurrent condition

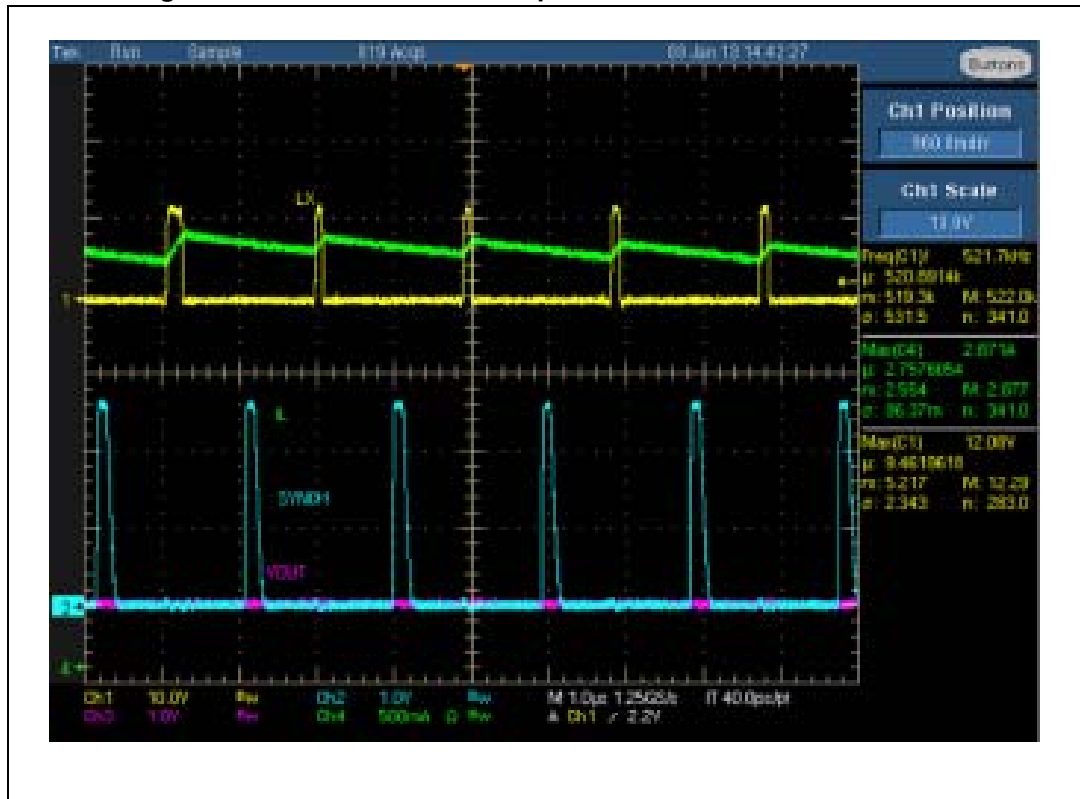

The DC current flowing in the load in overcurrent condition is:

Equation 17

$$I_{DCOC}(V_{OUT}) = I_{MAX} - \frac{I_{RIPPLE}(V_{OUT})}{2} = I_{MAX} - \left(\frac{V_{IN} - V_{OUT}}{2 \cdot L} \cdot T_{ON} \right)$$

OCP and switchover feature

Output capacitor discharging the current flowing to ground during heavy short-circuit events is only limited by parasitic elements like the output capacitor ESR and short-circuit impedance.

Due to parasitic inductance of the short-circuit impedance, negative output voltage oscillations can be generated with huge discharging current levels (see [Figure 20](#)).

Figure 20. Output voltage oscillations during heavy short-circuit

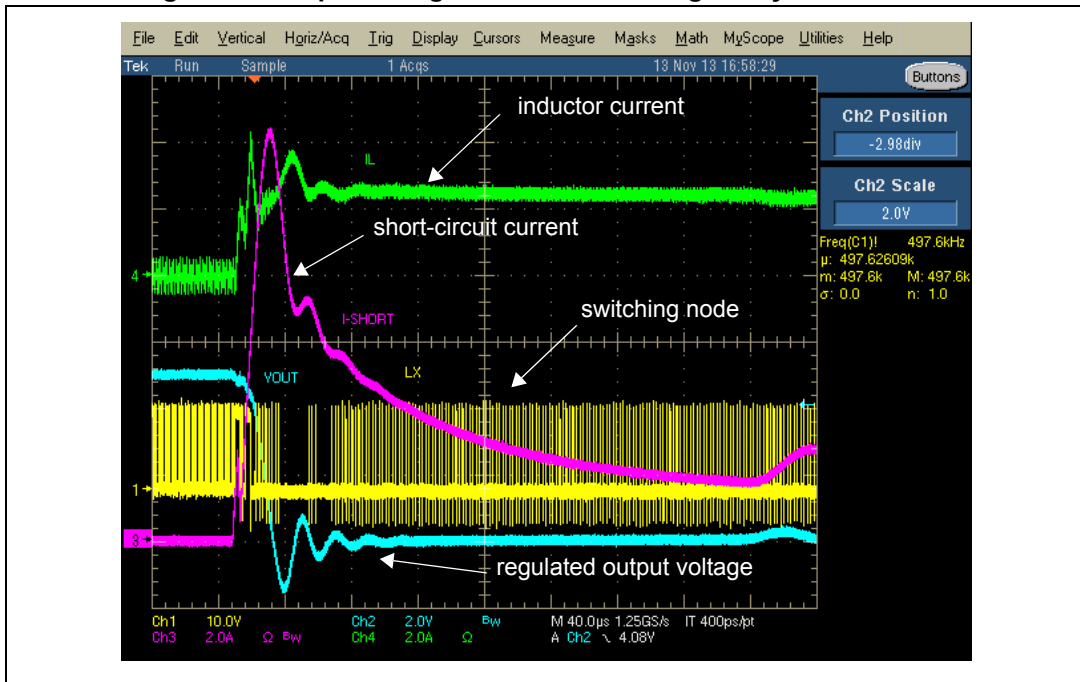

Figure 21. Zoomed waveform



The V_{BIAS} pin absolute maximum ratings (see [Table 2: Absolute maximum ratings on page 6](#)) must be satisfied over the different dynamic conditions.

If V_{BIAS} is connected to GND there are no issues (see [Figure 20](#) and [Figure 21](#)).

A small resistor value (few ohms) in series with V_{BIAS} can help to limit the pin negative voltage (see [Figure 22](#)) during heavy short-circuit events if it is connected to the regulated output voltage.

Figure 22. V_{BIAS} in heavy short-circuit event

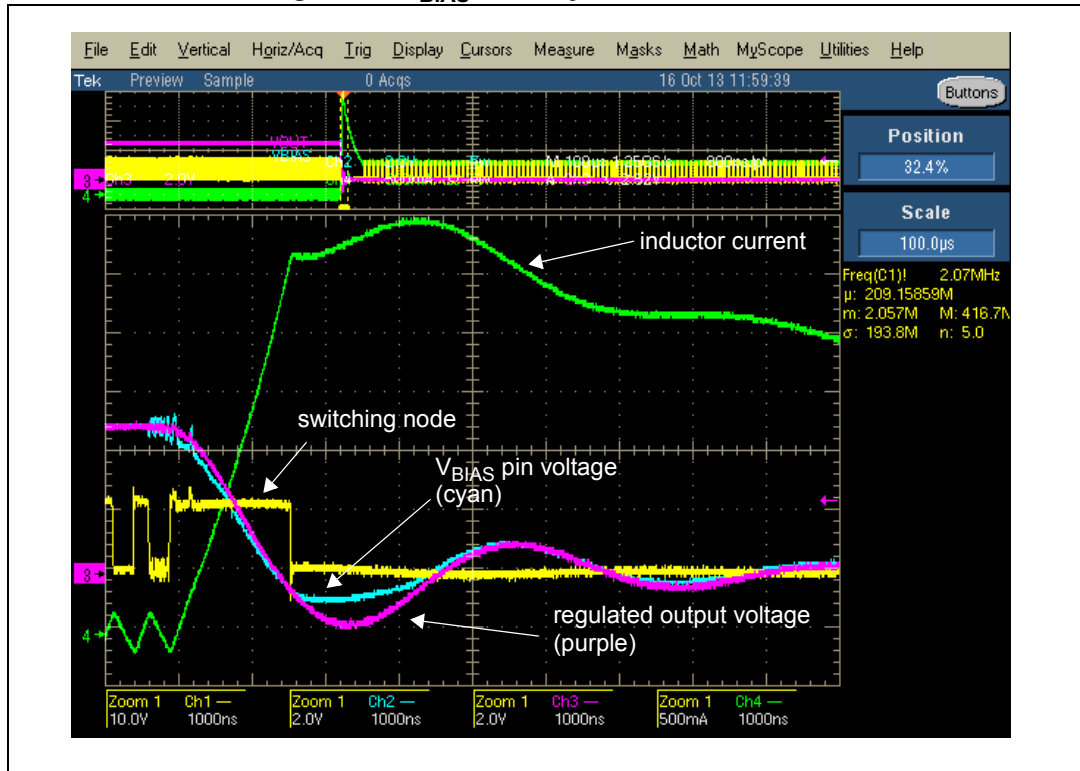

4.8 Overvoltage protection

The overvoltage protection monitors the FB pin and enables the low-side MOSFET to discharge the output capacitor if the output voltage is 20% over the nominal value.

This is a second level protection and should never be triggered in normal operating conditions if the system is properly dimensioned. In other words, the selection of the external power components and the dynamic performance determined by the compensation network should guarantee an output voltage regulation within the overvoltage threshold even during the worst case scenario in term of load transitions.

The protection is reliable and also able to operate even during normal load transitions for a system whose dynamic performance is not in line with the load dynamic request. As a consequence the output voltage regulation would be affected.

[Figure 23](#) shows the overvoltage operation during a negative step load transient for a system designed with huge inductor value and small output capacitor. The inductor value limits the switch current slew rate and the extra charge flowing into the small capacitor value generates an overvoltage event. This can be considered as an example for a system with dynamic performance not in line with the load request.

The L6986 device implements a 1 A typ. negative current limitation to limit the maximum reversed switch current during the overvoltage operation.

Figure 23. Overvoltage operation

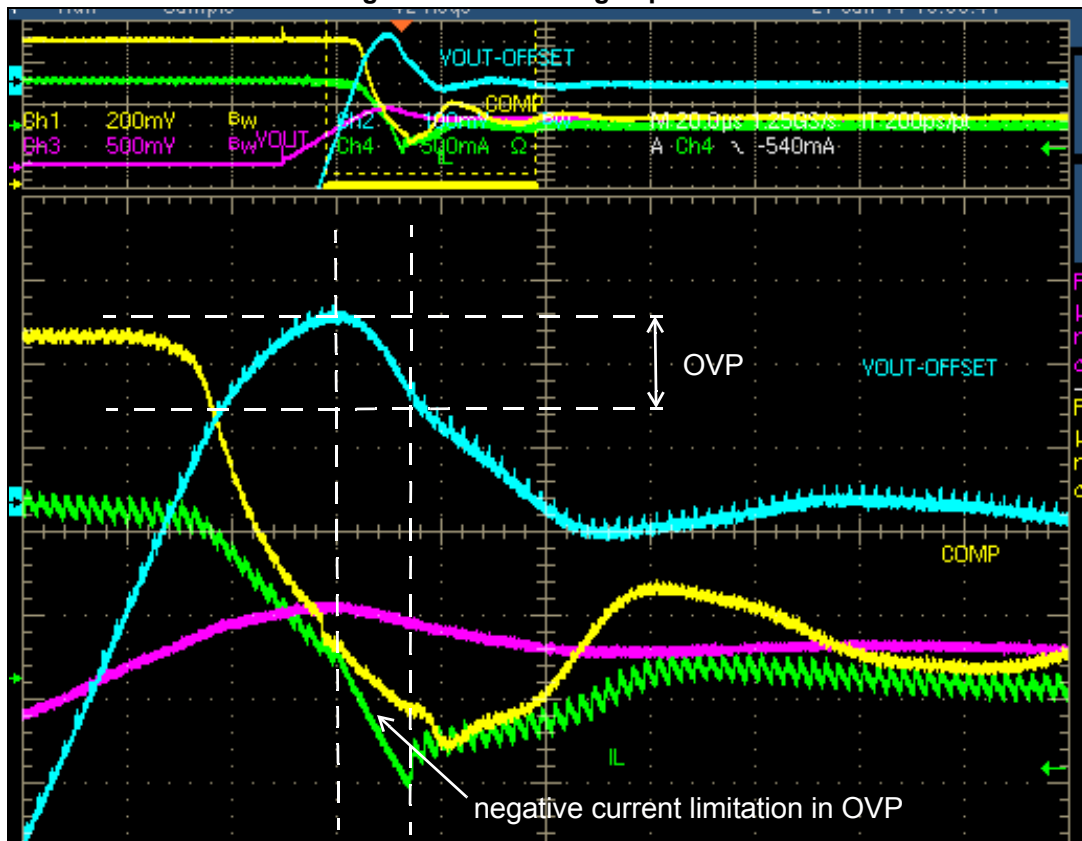

4.9 Thermal shutdown

The shutdown block disables the switching activity if the junction temperature is higher than a fixed internal threshold (165 °C typical). The thermal sensing element is close to the power elements, ensuring fast and accurate temperature detection. A hysteresis of approximately 30 °C prevents the device from turning ON and OFF continuously. When the thermal protection runs away a new soft-start cycle will take place.

5 Closing the loop

Figure 24. Block diagram of the loop

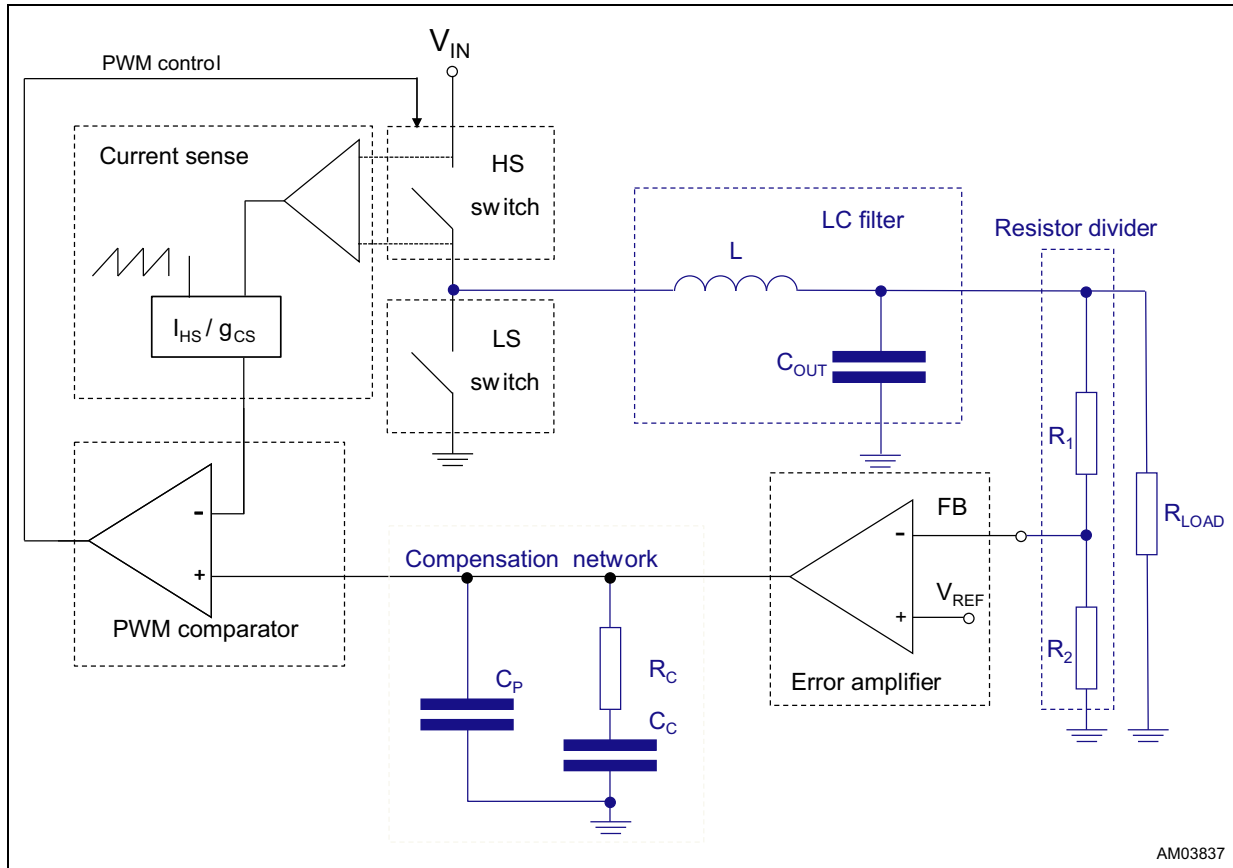

AM03837

5.1 $G_{CO}(s)$ control to output transfer function

The accurate control to output transfer function for a buck peak current mode converter can be written as:

Equation 18

$$G_{CO}(s) = \frac{R_{LOAD}}{R_i} \cdot \frac{1}{1 + \frac{R_{LOAD} \cdot T_{SW}}{L} \cdot [m_C \cdot (1-D) - 0.5]} \cdot \frac{\left(1 + \frac{s}{\omega_z}\right)}{\left(1 + \frac{s}{\omega_p}\right)} \cdot F_H(s)$$

where R_{LOAD} represents the load resistance, R_i the equivalent sensing resistor of the current sense circuitry, ω_p the single pole introduced by the power stage and ω_z the zero given by the ESR of the output capacitor.

$F_H(s)$ accounts the sampling effect performed by the PWM comparator on the output of the error amplifier that introduces a double pole at one half of the switching frequency.

Equation 19

$$\omega_z = \frac{1}{ESR \cdot C_{OUT}}$$

Equation 20

$$\omega_p = \frac{1}{R_{LOAD} \cdot C_{OUT}} + \frac{m_c \cdot (1 - D) - 0.5}{L \cdot C_{OUT} \cdot f_{SW}}$$

where:

Equation 21

$$\begin{cases} m_c = 1 + \frac{S_e}{S_n} \\ S_e = V_{PP} \cdot g_{CS} \cdot f_{SW} \\ S_n = \frac{V_{IN} - V_{OUT}}{L} \end{cases}$$

S_n represents the on time slope of the sensed inductor current, S_e the on time slope of the external ramp (V_{PP} peak-to-peak amplitude) that implements the slope compensation to avoid sub-harmonic oscillations at duty cycle over 50%.

S_e can be calculated from the parameter $V_{PP} \cdot g_{CS}$ given in [Table 5 on page 8](#).

The sampling effect contribution $F_H(s)$ is:

Equation 22

$$F_H(s) = \frac{1}{1 + \frac{s}{\omega_n \cdot Q_p} + \frac{s^2}{\omega_n^2}}$$

where:

Equation 23

$$Q_p = \frac{1}{\pi \cdot [m_c \cdot (1 - D) - 0.5]}$$

5.2 Error amplifier compensation network

The typical compensation network required to stabilize the system is shown in [Figure 25](#).

Figure 25. Transconductance embedded error amplifier

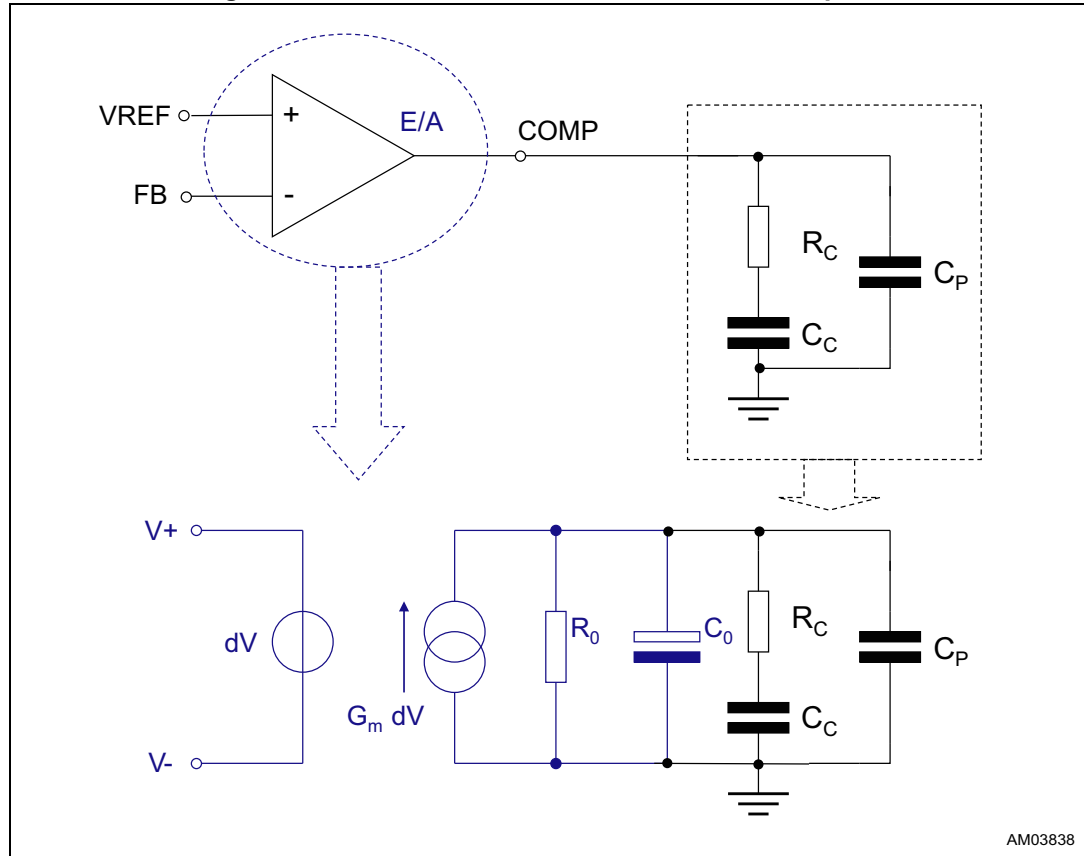

R_C and C_C introduce a pole and a zero in the open loop gain. C_P does not significantly affect system stability but it is useful to reduce the noise at the output of the error amplifier.

The transfer function of the error amplifier and its compensation network is:

Equation 24

$$A_0(s) = \frac{A_{V0} \cdot (1 + s \cdot R_C \cdot C_C)}{s^2 \cdot R_0 \cdot (C_0 + C_P) \cdot R_C \cdot C_C + s \cdot (R_0 \cdot C_C + R_0 \cdot (C_0 + C_P) + R_C \cdot C_C) + 1}$$

Where $A_{V0} = G_m \cdot R_0$

The poles of this transfer function are (if $C_C \gg C_0 + C_P$):

Equation 25

$$f_{PLF} = \frac{1}{2 \cdot \pi \cdot R_0 \cdot C_C}$$

Equation 26

whereas the zero is defined as:

$$f_{PHF} = \frac{1}{2 \cdot \pi \cdot R_0 \cdot (C_0 + C_p)}$$

Equation 27

$$f_z = \frac{1}{2 \cdot \pi \cdot R_c \cdot C_c}$$

5.3 Voltage divider

The contribution of a simple voltage divider is:

Equation 28

$$G_{DIV}(s) = \frac{R_2}{R_1 + R_2}$$

A small signal capacitor in parallel to the upper resistor (see [Figure 26](#)) of the voltage divider implements a leading network ($f_{zero} < f_{pole}$), sometimes necessary to improve the system phase margin:

Figure 26. Leading network example

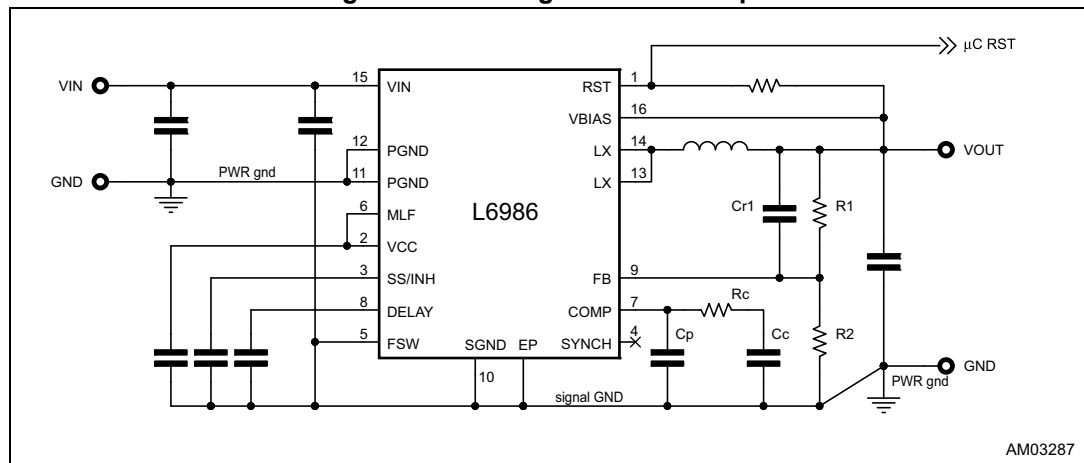

Laplace transformer of the leading network:

Equation 29

$$G_{DIV}(s) = \frac{R_2}{R_1 + R_2} \cdot \frac{(1 + s + R_1 \cdot C_{R1})}{\left(1 + s \cdot \frac{R_1 \cdot R_2}{R_1 + R_2} \cdot C_{R1}\right)}$$

where:

Equation 30

$$f_z = \frac{1}{2 \cdot \pi \cdot R_1 \cdot C_{R1}}$$

$$f_p = \frac{1}{2 \cdot \pi \cdot \frac{R_1 \cdot R_2}{R_1 + R_2} \cdot C_{R1}}$$

$$f_z < f_p$$

5.4 Total loop gain

In summary, the open loop gain can be expressed as:

Equation 31

$$G(s) = G_{DIV}(s) \cdot G_{CO}(s) \cdot A_0(s)$$

Example 1

$$V_{IN} = 12 \text{ V}, V_{OUT} = 3.3 \text{ V}, R_{OUT} = 2.2 \Omega$$

Selecting $L = 6.8 \mu\text{H}$, $C_{OUT} = 15 \mu\text{F}$ and $\text{ESR} = 1 \text{ m}\Omega$, $R_C = 68 \text{ k}\Omega$, $C_C = 180 \text{ pF}$, $C_P = 6.8 \text{ pF}$ (please refer to [Example 2](#)), the gain and phase bode diagrams are plotted respectively in [Figure 27](#) and [Figure 28](#).

Figure 27. Module plot

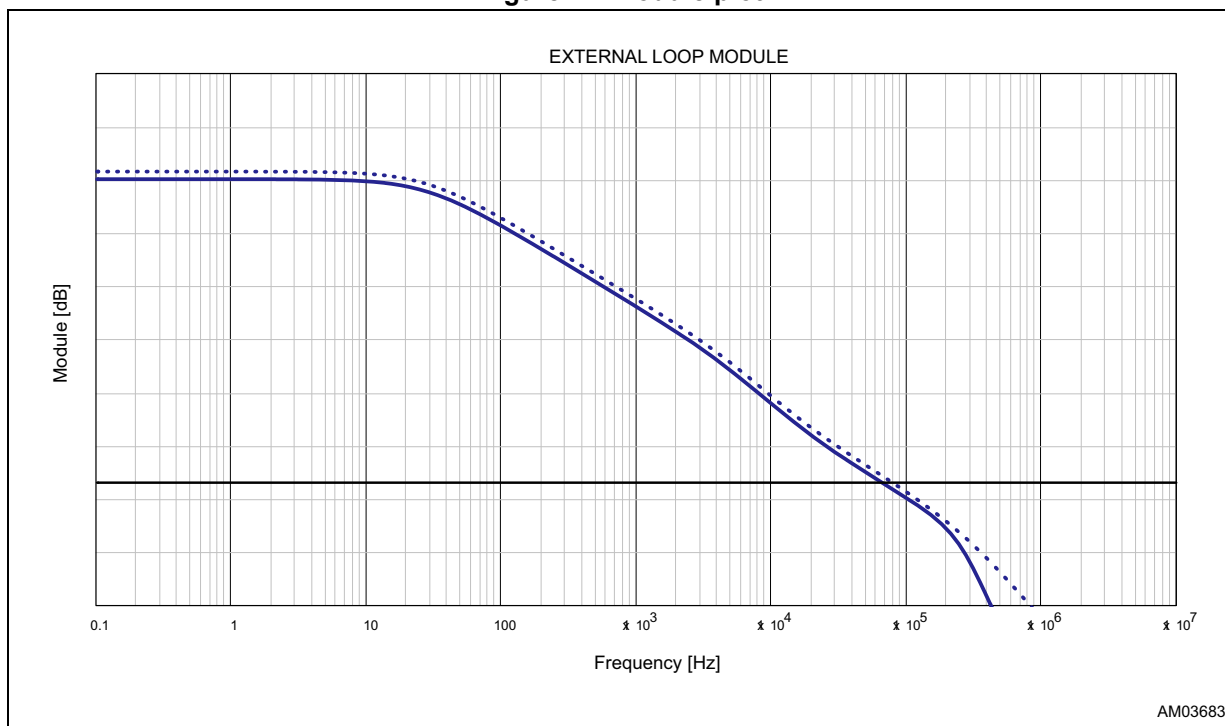

Equation 32

$$BW = 67\text{kHz}$$

$$\text{Phase margin} = 53^\circ$$

Figure 28. Phase plot

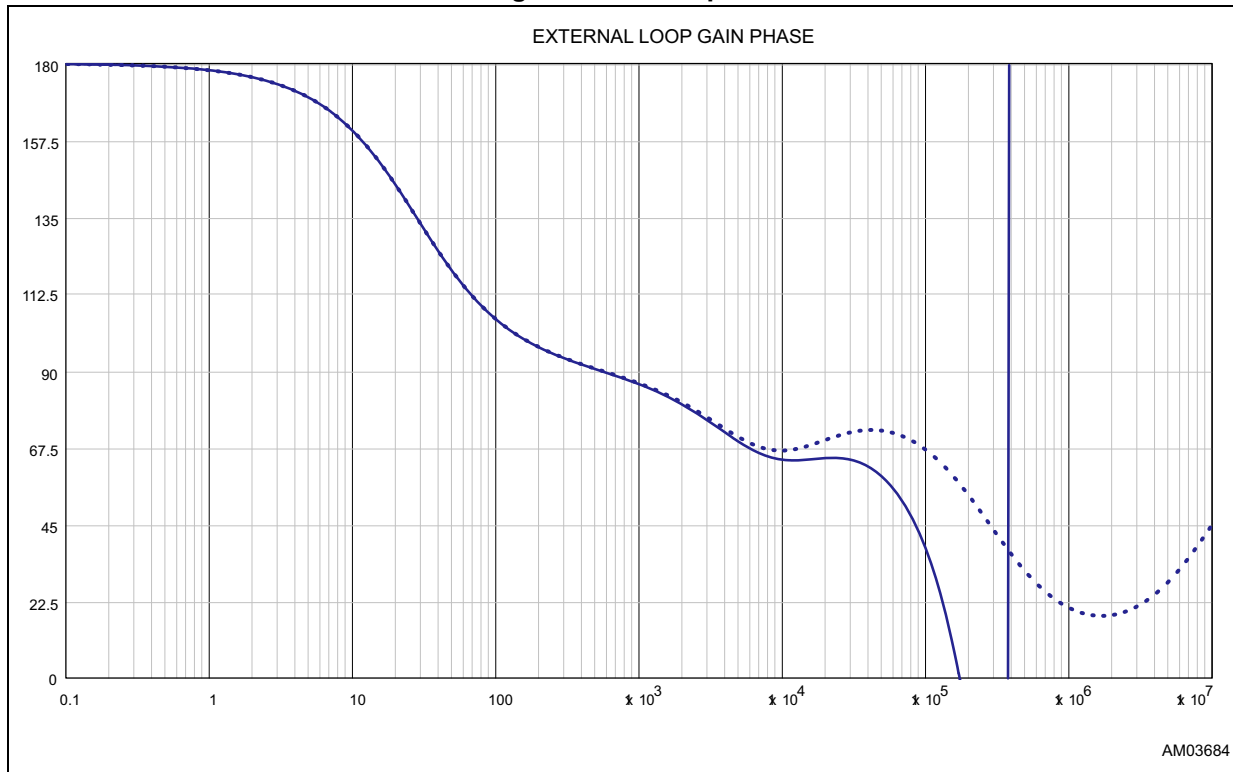

The blue solid trace represents the transfer function including the sampling effect term (see [Equation 21 on page 34](#)), the dotted blue trace neglects the contribution.

5.5 Compensation network design

The maximum bandwidth of the system can be designed up to $f_{SW}/6$ to guarantee a valid small signal model.

Equation 33

$$BW = \frac{f_{SW}}{6}$$

Equation 34

$$R_C = \frac{2 \cdot \pi \cdot BW \cdot C_{OUT} \cdot V_{OUT}}{0.85V \cdot g_{CS} \cdot g_{m\ TYP}}$$

where:

Equation 35

$$f_{POLE} = \frac{\omega_p}{2 \cdot \pi}$$

ω_p is defined by [Equation 20 on page 34](#), g_{CS} represents the current sense transconductance (see [Table 5: Electrical characteristics on page 8](#)) and $g_{m\ TYP}$ the error amplifier transconductance.

Equation 36

$$C_C = \frac{5}{2 \cdot \pi \cdot R_C \cdot BW}$$

Example 2

Considering $V_{IN} = 12 \text{ V}$, $V_{OUT} = 3.3 \text{ V}$, $L = 6.8 \mu\text{H}$, $C_{OUT} = 15 \mu\text{F}$, $f_{SW} = 500 \text{ kHz}$.

The maximum system bandwidth is 80 kHz. Assuming to design the compensation network to achieve a system bandwidth of 70 kHz:

Equation 37

$$f_{POLE} = 6 \text{ kHz}$$

Equation 38

$$R_{LOAD} = \frac{V_{OUT}}{I_{OUT}} = 2.2 \Omega$$

so accordingly with [Equation 34](#) and [Equation 36](#):

Equation 39

$$R_C = 68 \text{ k}\Omega$$

Equation 40

$$C_C = 168 \text{ pF} \approx 180 \text{ pF}$$

6 Application notes

6.1 Output voltage adjustment

The error amplifier reference voltage is 0.85 V typical.

The output voltage is adjusted accordingly with [Equation 41](#) (see [Figure 29](#)):

Equation 41

$$V_{OUT} = 0.85 \cdot \left(1 + \frac{R_1}{R_2}\right)$$

C_{r1} capacitor is sometimes useful to increase the small signal phase margin (please refer to [Section 5.5: Compensation network design](#)).

Figure 29. L6986 application circuit

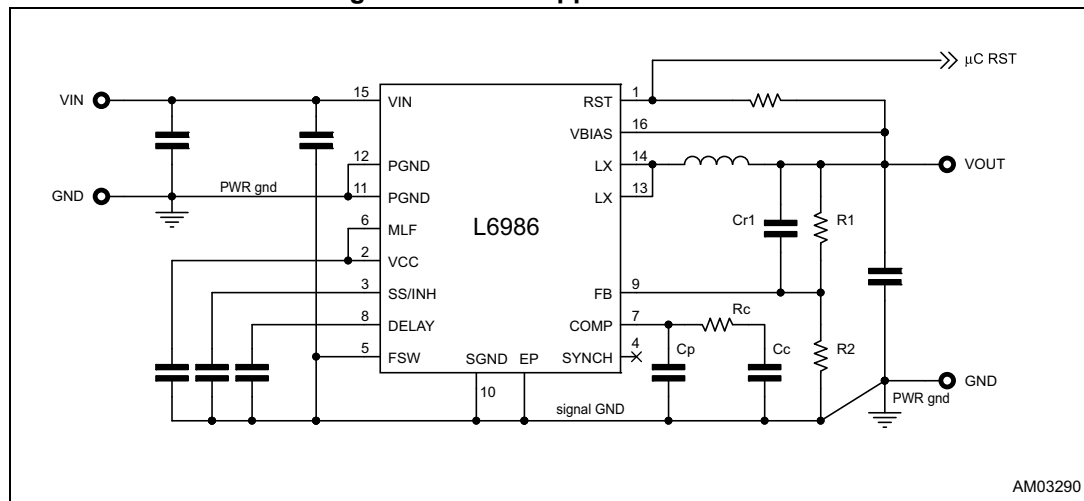

6.2 Switching frequency

A resistor connected to the FSW pin features the selection of the switching frequency. The pinstrapping is performed at power-up, before the soft-start takes place. The FSW pin is pinstrapped and then driven floating in order to minimize the quiescent current from VIN.

Please refer to [Table 6: \$f_{SW}\$ selection on page 11](#) to identify the pull-up / pull-down resistor value. $f_{SW} = 250$ kHz / $f_{SW} = 500$ kHz preferred codifications don't require any external resistor.

6.3 MLF pin

A resistor connected to the MLF pin features the selection of the between low noise mode / low consumption mode and the different RST thresholds. The pinstrapping is performed at power-up, before the soft-start takes place. The FSW pin is pinstrapped and then driven floating in order to minimize the quiescent current from VIN.

Please refer to [Table 7: LNM / LCM selection on page 11](#) to identify the pull-up / pull-down resistor value. (LNM, RST threshold 93%) / (LCM, RST threshold 93%) preferred codifications don't require any external resistor.

6.4 Voltage supervisor

The embedded voltage supervisor (composed of the RST and the DELAY pins) monitors the regulated output voltage and keeps the RST open collector output in low impedance as long as the V_{OUT} is out of regulation. In order to ensure a proper reset of digital devices with a valid power supply, the device can delay the RST assertion with a programmable time.

Figure 30. Voltage supervisor operation

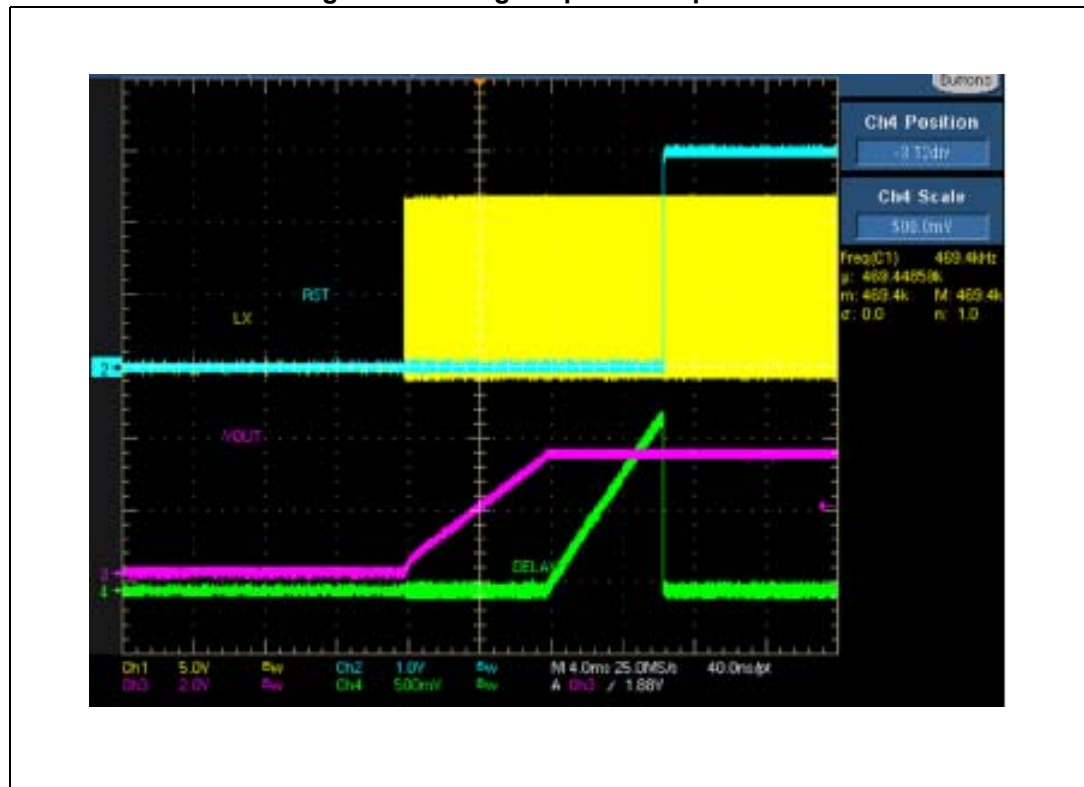

The comparator monitoring the FB voltage has four different programmable thresholds (80%, 87%, 93%, 96% nominal output voltage) for high flexibility (see [Section 6.3: MLF pin](#) and [Table 7: LNM / LCM selection on page 11](#)).

When the RST comparator detects the output voltage is in regulation, a $2\ \mu\text{A}$ internal current source starts to charge an external capacitor to implement a voltage ramp on the DELAY pin. The RST open collector is then released as soon as $V_{DELAY} = 1.234\ \text{V}$ (see [Figure 30](#)).

The C_{DELAY} is dimensioned accordingly with [Equation 42](#):

Equation 42

$$C_{DELAY} = \frac{I_{SSCH} \cdot T_{DELAY}}{V_{DELAY}} = \frac{2\ \mu\text{A} \cdot T_{DELAY}}{1.234\ \text{V}}$$

The maximum suggested capacitor value is 270 nF.

6.5 Synchronization (LNM)

Beating frequency noise is an issue when multiple switching regulators populate the same application board. The L6986 synchronization circuitry features the same switching frequency for a set of regulators simply connecting their SYNCH pin together, so preventing beating noise. The master device provides the synchronization signal to the others since the SYNCH pin is I/O able to deliver or recognize a frequency signal.

For proper synchronization of multiple regulators, all of them have to be configured with the same switching frequency (see [Table 6](#)), so the same resistor connected at the FSW pin.

In order to minimize the RMS current flowing through the input filter, the L6986 device provides a phase shift of 180° between the master and the SLAVES. If more than two devices are synchronized, all slaves will have a common 180° phase shift with respect to the master.

Considering two synchronized L6986 which regulates the same output voltage (i.e. operating with the same duty cycle), the input filter RMS current is optimized and is calculated as:

Equation 43

$$I_{\text{RMS}} = \begin{cases} \frac{I_{\text{OUT}}}{2} \cdot \sqrt{2D \cdot (1 - 2D)} & \text{if } D < 0.5 \\ \frac{I_{\text{OUT}}}{2} \cdot \sqrt{(2D - 1) \cdot (2 - 2D)} & \text{if } D > 0.5 \end{cases}$$

The graphical representation of the input RMS current of the input filter in the case of two devices with 0° phase shift (synchronized to an external signal) or 180° phase shift (synchronized connecting their SYNCH pins) regulating the same output voltage is provided in [Figure 31](#). To dimension the proper input capacitor please refer to [Chapter 6.6.1: Input capacitor selection](#).

Figure 31. Input RMS current

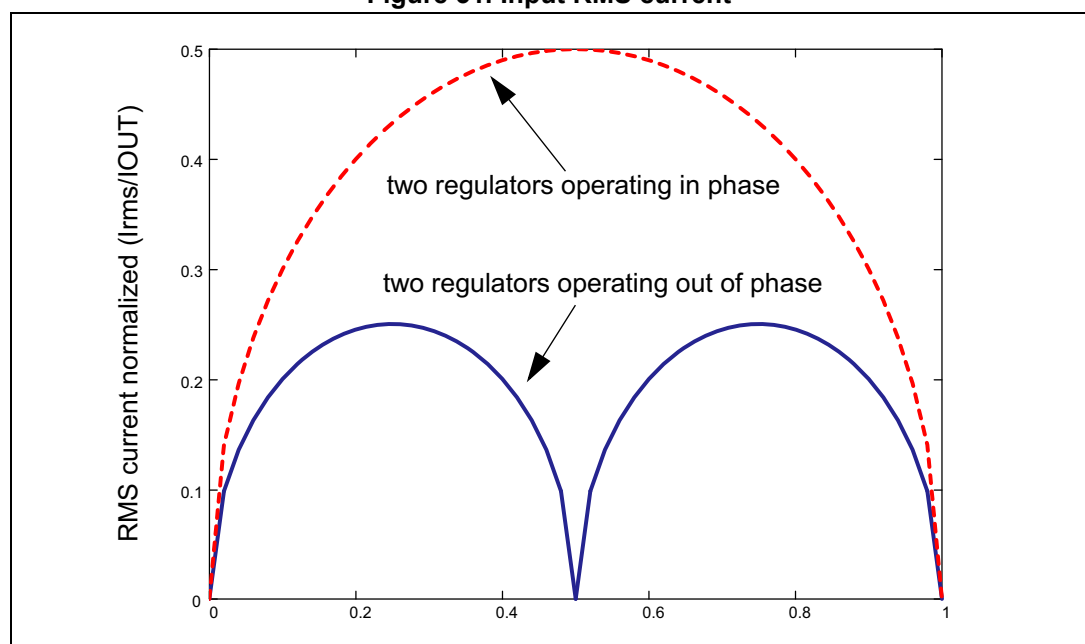

Figure 32 shows two regulators not synchronized.

Figure 32. Two regulators not synchronized



Figure 33 shows the same regulators working synchronized. The MASTER regulator (LX2 trace) delivers the synchronization signal (SYNCH1, SYNCH2 pins are connected together) to the SLAVE device (LX1). The SLAVE regulator works in phase with the synchronization signal which is out of phase with the MASTER switching operation.

Figure 33. Two regulators synchronized



Multiple L6986 can be synchronized to an external frequency signal fed to the SYNCH pin. In this case the regulator is phased to the reference and all the devices will work with 0° phase shift.

The frequency range of the synchronization signal is 275 kHz - 2 MHz and the minimum pulse width is 100 nsec (see [Figure 34](#)).

Figure 34. Synchronization pulse definition

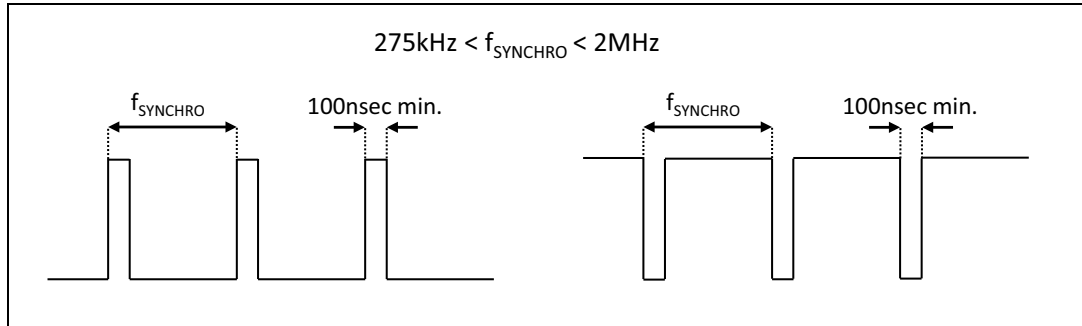

Since the slope compensation contribution that is required to prevent subharmonic oscillations in peak current mode architecture depends on the switching frequency, it is important to select the same oscillator frequency for all regulators (all of them operate as SLAVE) as close as possible to the frequency of the reference signal (please refer to [Table 6: \$f_{SW}\$ selection on page 11](#)). As a consequence all the regulators have the same resistor value connected to the FSW pin, so the slope compensation is optimized accordingly with the frequency of the synchronization signal. The slope compensation contribution is latched at power-up and so fixed during the device operation.

The L6986 normally operates in MASTER mode, driving the SYNCH line at the selected oscillator frequency as shown in [Figure 35](#) and [Figure 36](#).

In SLAVE mode the L6986 sets the internal oscillator at 250 kHz typ. (see [Table 6 on page 11](#) - first row) and drives the line accordingly.

Figure 35. L6986 synchronization driving capability

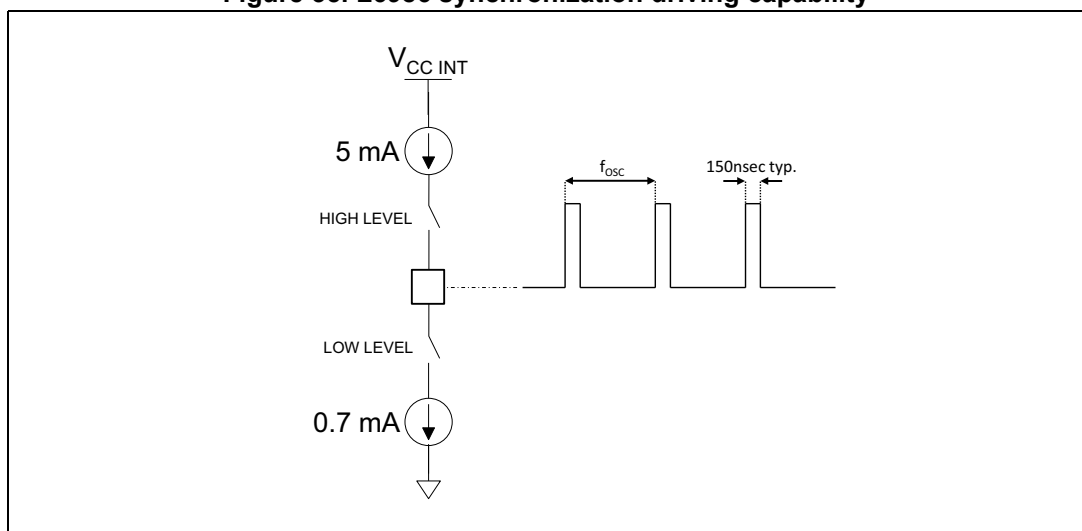

In order to safely guarantee that each regulator recognizes itself in SLAVE mode during the normal operation, the external master must drive the SYNCH pin with a clock signal

frequency higher than the maximum oscillator spread (refer to [Table 6 on page 11](#)) for at least 10 internal clock cycles.

For example: selecting $R_{FSW} = 0 \Omega$ to GND

Table 9. Example of oscillator frequency selection from [Table 6](#)

Symbol	R_{VCC} (E24 series)	R_{GND} (E24 series)	f_{SW} min.	f_{SW} typ.	f_{SW} max.
f_{SW}	NC	0Ω	450	500	550

the device enters in slave mode after 10 pulses at frequency higher than 550 kHz and so it is able to synchronize to a clock signal in the range 275 kHz - 2 MHz (see [Figure 34](#)).

Anyway it is suggested to limit the frequency range within $\pm 20\%$ FSW resistor nominal frequency (see details in text below). If not spread spectrum is required, all the regulators synchronize to a frequency higher to the maximum oscillator spread (550 kHz in the example).

The device keeps operating in slave mode as far as the master is able to drive the SYNCH pin faster than 275 kHz (maximum oscillator spread for 250 kHz oscillator), otherwise it goes back into MASTER mode at the nominal oscillator frequency after successfully driving one pulse at 250 kHz (see [Figure 36](#)) in the SYNCH line.

Figure 36. Slave to master mode transition

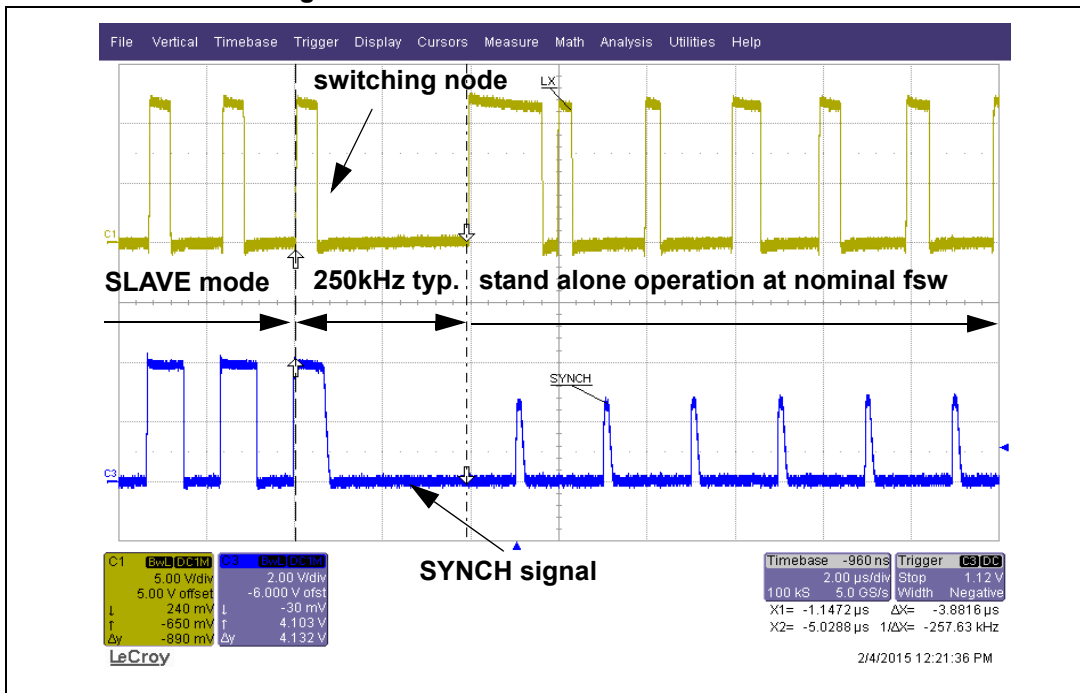

The external master can force a latched SLAVE mode driving the SYNCH pin low at power-up, before the soft-start starts the switching activity. So the oscillator frequency is 250 kHz typ. fixed until a new UVLO event is triggered regardless FSW resistor value, that otherwise counts to design the slope compensation. The same considerations above are also valid.

The master driving capability must be able to provide the proper signal levels at the SYNCH pin (see [Table 5 on page 8](#) - Synchronization section):

- Low level $< V_{\text{SYN_THL}} = 0.7 \text{ V}$ sinking 5 mA
- High level $> V_{\text{SYN_THH}} = 1.2 \text{ V}$ sourcing 0.7 mA

Figure 37. Master driving capability to synchronize the L6986

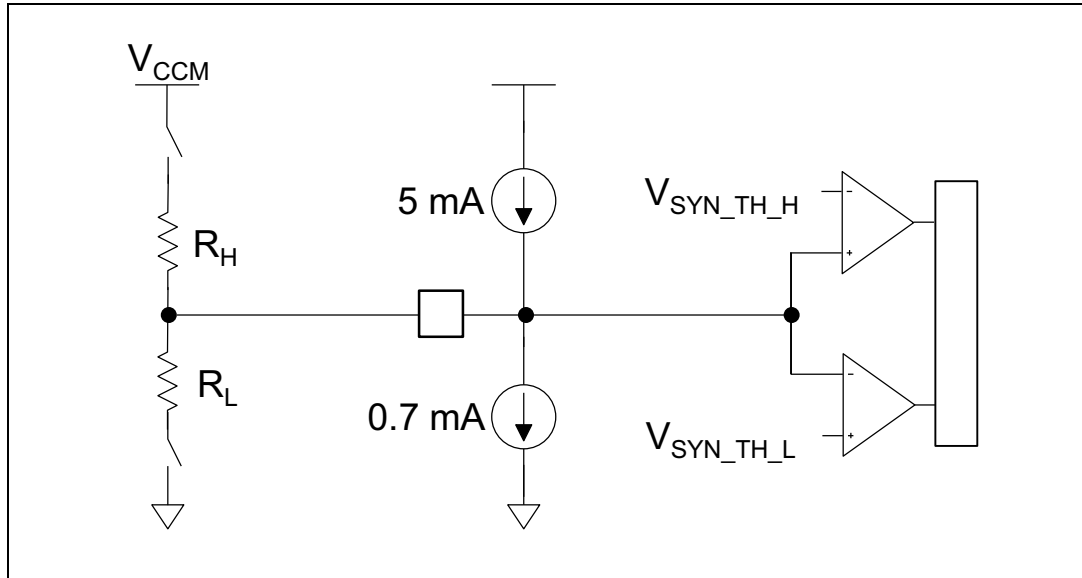

As anticipated above, in SLAVE mode the internal oscillator operates at 250 kHz typ. but the slope compensation is dimensioned accordingly with FSW resistors so, even if the L6986 supports synchronization over the $275 \text{ kHz} - 2 \text{ MHz}$ frequency range, it is important to limit the switching operation around a working point close to the selected frequency (FSW resistor).

As a consequence, to guarantee the full output current capability and to prevent the subharmonic oscillations the master must limit the driving frequency range within $\pm 20\%$ of the selected frequency.

A wider frequency range may generate subharmonic oscillation for duty $> 50\%$ or limit the peak current capability (see I_{PK} parameter in [Table 5](#)) since the internal slope compensation signal may be saturated.

Since the slope compensation contribution, that is required to prevent subharmonic oscillations in peak current mode architecture, depends on the switching frequency, it is important to select the same switching frequency for all regulators (all of them operate as SLAVE) one step lower than the reference signal (please refer to [Table 6: \$f_{\text{SW}}\$ selection on page 11](#)). As a consequence, all the regulators have the same resistor connected to the FSW pin.

6.6 Design of the power components

6.6.1 Input capacitor selection

The input capacitor voltage rating must be higher than the maximum input operating voltage of the application. During the switching activity a pulsed current flows into the input capacitor and so its RMS current capability must be selected accordingly with the application conditions. Internal losses of the input filter depends on the ESR value so usually low ESR capacitors (like multilayer ceramic capacitors) have higher RMS current capability. On the

other hand, given the RMS current value, lower ESR input filter has lower losses and so contributes to higher conversion efficiency.

The maximum RMS input current flowing through the capacitor can be calculated as:

Equation 44

$$I_{RMS} = I_{OUT} \cdot \sqrt{\left(1 - \frac{D}{\eta}\right) \cdot \frac{D}{\eta}}$$

Where I_O is the maximum DC output current, D is the duty cycles, η is the efficiency. This function has a maximum at $D = 0.5$ and, considering $\eta = 1$, it is equal to $I_O/2$.

In a specific application the range of possible duty cycles has to be considered in order to find out the maximum RMS input current. The maximum and minimum duty cycles can be calculated as:

Equation 45

$$D_{MAX} = \frac{V_{OUT} + \Delta V_{LOW_SIDE}}{V_{INMIN} + \Delta V_{LOW_SIDE} - \Delta V_{HIGH_SIDE}}$$

Equation 46

$$D_{MIN} = \frac{V_{OUT} + \Delta V_{LOW_SIDE}}{V_{INMAX} + \Delta V_{LOW_SIDE} - \Delta V_{HIGH_SIDE}}$$

Where ΔV_{HIGH_SIDE} and ΔV_{LOW_SIDE} are the voltage drops across the embedded switches. The peak to peak voltage across the input filter can be calculated as:

Equation 47

$$V_{PP} = \frac{I_{OUT}}{C_{IN} \cdot f_{SW}} \cdot \left(1 - \frac{D}{\eta}\right) \cdot \frac{D}{\eta} + ESR \cdot (I_{OUT} + \Delta I_L)$$

In case of negligible ESR (MLCC capacitor) the equation of C_{IN} as a function of the target VPP can be written as follows:

Equation 48

$$C_{IN} = \frac{I_{OUT}}{V_{PP} \cdot f_{SW}} \cdot \left(1 - \frac{D}{\eta}\right) \cdot \frac{D}{\eta}$$

Considering $\eta = 1$ this function has its maximum in $D = 0.5$:

Equation 49

$$C_{INMIN} = \frac{I_{OUT}}{4 \cdot V_{PPMAX} \cdot f_{SW}}$$

Typically C_{IN} is dimensioned to keep the maximum peak-peak voltage across the input filter in the order of 5% V_{IN_MAX} .

Table 10. Input capacitors

Manufacturer	Series	Size	Cap value (μF)	Rated voltage (V)
TDK	C3225X7S1H106M	1210	10	50
	C3216X5R1H106M	1206		
Taiyo Yuden	UMK325BJ106MM-T	1210		

6.6.2 Inductor selection

The inductor current ripple flowing into the output capacitor determines the output voltage ripple (please refer to [Section 6.6.3](#)). Usually the inductor value is selected in order to keep the current ripple lower than 20% - 40% of the output current over the input voltage range. The inductance value can be calculated by [Equation 50](#):

Equation 50

$$\Delta I_L = \frac{V_{IN} - V_{OUT}}{L} \cdot T_{ON} = \frac{V_{OUT}}{L} \cdot T_{OFF}$$

Where T_{ON} and T_{OFF} are the on and off time of the internal power switch. The maximum current ripple, at fixed V_{OUT} , is obtained at maximum T_{OFF} that is at minimum duty cycle (see [Section 6.6.1: Input capacitor selection](#) to calculate minimum duty). So fixing $\Delta I_L = 20\%$ to 40% of the maximum output current, the minimum inductance value can be calculated:

Equation 51

$$L_{MIN} = \frac{V_{OUT}}{\Delta I_{LMAX}} \cdot \frac{1 - D_{MIN}}{F_{SW}}$$

where f_{SW} is the switching frequency $1/(T_{ON} + T_{OFF})$.

For example for $V_{OUT} = 3.3$ V, $V_{IN} = 12$ V, $I_O = 2$ A and $F_{SW} = 500$ kHz the minimum inductance value to have $\Delta I_L = 30\%$ of I_O is about 8.2 μH.

The peak current through the inductor is given by:

Equation 52

$$I_{L,PK} = I_{OUT} + \frac{\Delta I_L}{2}$$

So if the inductor value decreases, the peak current (that has to be lower than the current limit of the device) increases. The higher is the inductor value, the higher is the average output current that can be delivered, without reaching the current limit.

In [Table 11](#) some inductor part numbers are listed.

Table 11. Inductors

Manufacturer	Series	Inductor value (μH)	Saturation current (A)
Coilcraft	XAL50xx	2.2 to 22	6.5 to 2.7
	XAL60xx	2.2 to 22	12.5 to 4

6.6.3 Output capacitor selection

The triangular shape current ripple (with zero average value) flowing into the output capacitor gives the output voltage ripple, that depends on the capacitor value and the equivalent resistive component (ESR). As a consequence the output capacitor has to be selected in order to have a voltage ripple compliant with the application requirements.

The voltage ripple equation can be calculated as:

Equation 53

$$\Delta V_{OUT} = ESR \cdot \Delta I_{LMAX} + \frac{\Delta I_{LMAX}}{8 \cdot C_{OUT} \cdot f_{SW}}$$

Usually the resistive component of the ripple can be neglected if the selected output capacitor is a multi layer ceramic capacitor (MLCC).

The output capacitor is important also for loop stability: it determines the main pole and the zero due to its ESR. (see [Section 5: Closing the loop on page 33](#) to consider its effect in the system stability).

For example with $V_{OUT} = 3.3 \text{ V}$, $V_{IN} = 12 \text{ V}$, $\Delta I_L = 0.6 \text{ A}$, $f_{SW} = 500 \text{ kHz}$ (resulting by the inductor value) and $C_{OUT} = 10 \text{ }\mu\text{F}$ MLCC:

Equation 54

$$\frac{\Delta V_{OUT}}{V_{OUT}} \cong \frac{1}{V_{OUT}} \cdot \frac{\Delta I_{LMAX}}{C_{OUT} \cdot f_{SW}} = \left(\frac{1}{3.3} \cdot \frac{0.6}{8 \cdot 10 \mu\text{F} \cdot 500 \text{kHz}} \right) = \frac{15 \text{mV}}{3.3} = 0.45\%$$

The output capacitor value has a key role to sustain the output voltage during a steep load transient. When the load transient slew rate exceeds the system bandwidth, the output capacitor provides the current to the load. In case the final application specifies high slew rate load transient, the system bandwidth must be maximized and the output capacitor has to sustain the output voltage for time response shorter than the loop response time.

In [Table 12](#) some capacitor series are listed.

Table 12. Output capacitors

Manufacturer	Series	Cap value (μF)	Rated voltage (V)	ESR ($\text{m}\Omega$)
MURATA	GRM32	22 to 100	6.3 to 25	< 5
	GRM31	10 to 47	6.3 to 25	< 5
PANASONIC	ECJ	10 to 22	6.3	< 5
	EEFCD	10 to 68	6.3	15 to 55
SANYO	TPA/B/C	100 to 470	4 to 16	40 to 80
TDK	C3225	22 to 100	6.3	< 5

7 Application board

The reference evaluation board schematic is shown in [Figure 38](#).

Figure 38. Evaluation board schematic

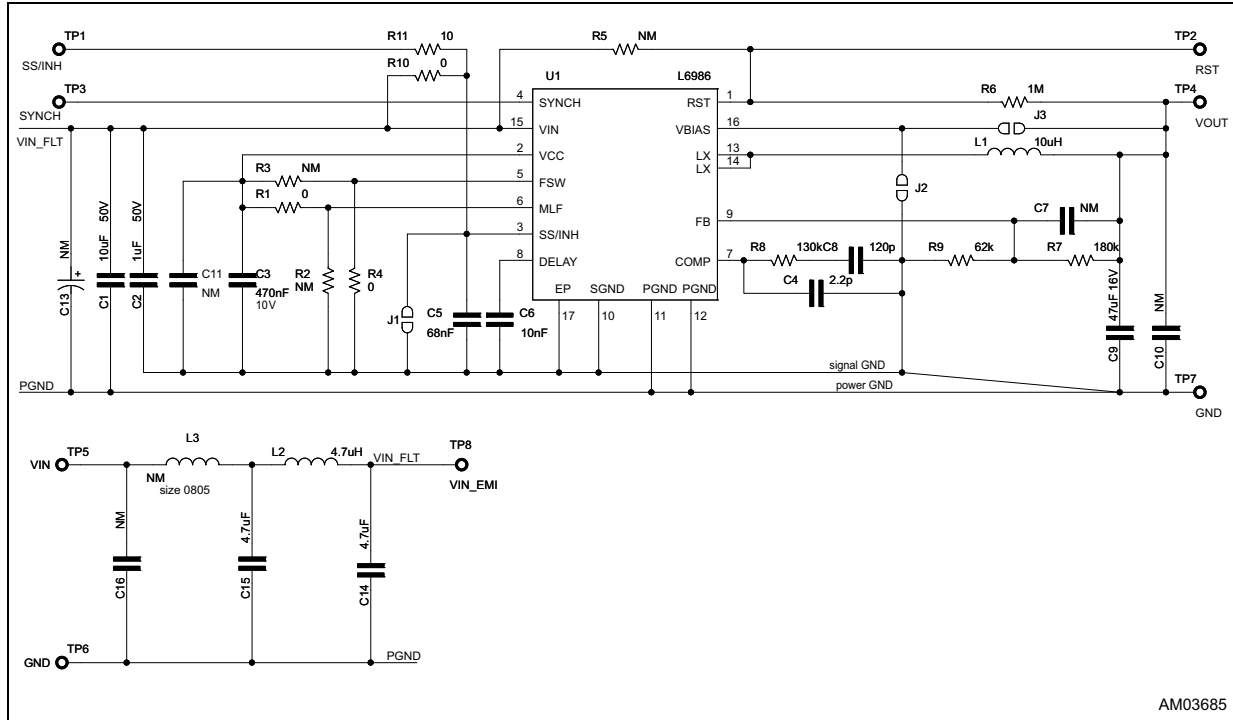

The additional input filter (C16, L3, C15, L2, C14) limits the conducted emission on the power supply.

Table 13. Bill of material

Reference	Part number	Description	Manufacturer
C1	CGA5L3X5R1H106K	10 μ F - 1206 - 50 V - X7R - 10%	TDK
C2	C2012X7S2A105K	1 μ F - 0805 - 50 V - X7S - 10%	TDK
C3		470 nF - 50 V - 0603	
C4		2.2 pF - 50 V - 0603	
C5		68 nF - 50 V - 0603	
C6		10 nF - 50 V - 0603	
C8		120 pF - 50 V - 0603	
C1	CGA5L3X5R1H106K	10 μ F - 1206 - 50 V - X7R - 10%	TDK
C9	C3216X5R1C476M	47 μ F - 1206 - 16 V - X5R - 20%	TDK
C14, C15, C16	C3216X7R1H475K160AC	4.7 μ F - 1206 - 50 V - X7R - 10%	TDK
C7, C10, C11, C13		Not mounted	
R1, R4		0 R - 0603	

Table 13. Bill of material (continued)

Reference	Part number	Description	Manufacturer
R6		1 M Ω - 1% - 0603	
R7		180 k Ω - 1% - 0603	
R8		130 k Ω - 1% - 0603	
R9		62 k Ω - 1% - 0603	
R11		10 Ω - 1% - 0603	
R2, R3, R5, R10		Not mounted	
L1	XAL5050-103MEC	10 μ H	Coilcraft
L2	XAL5030-472MEC	4.7 μ H	Coilcraft
L3	MPZ2012S221A	EMC bead	TDK
J1	Open		
J2	Open		
J3	Closed	Switchover	
J4	Open		
U1	L6986		STM

[Figure 39](#) and [Figure 40](#) show the magnitude and phase margin Bode's plots related to the evaluation board presented in [Figure 38](#).

The small signal dynamic performance of the demonstration board is:

Equation 55

$$BW = 67\text{kHz}$$

$$\text{phase margin} = 53^{\circ}$$

Figure 39. Magnitude Bode's plot

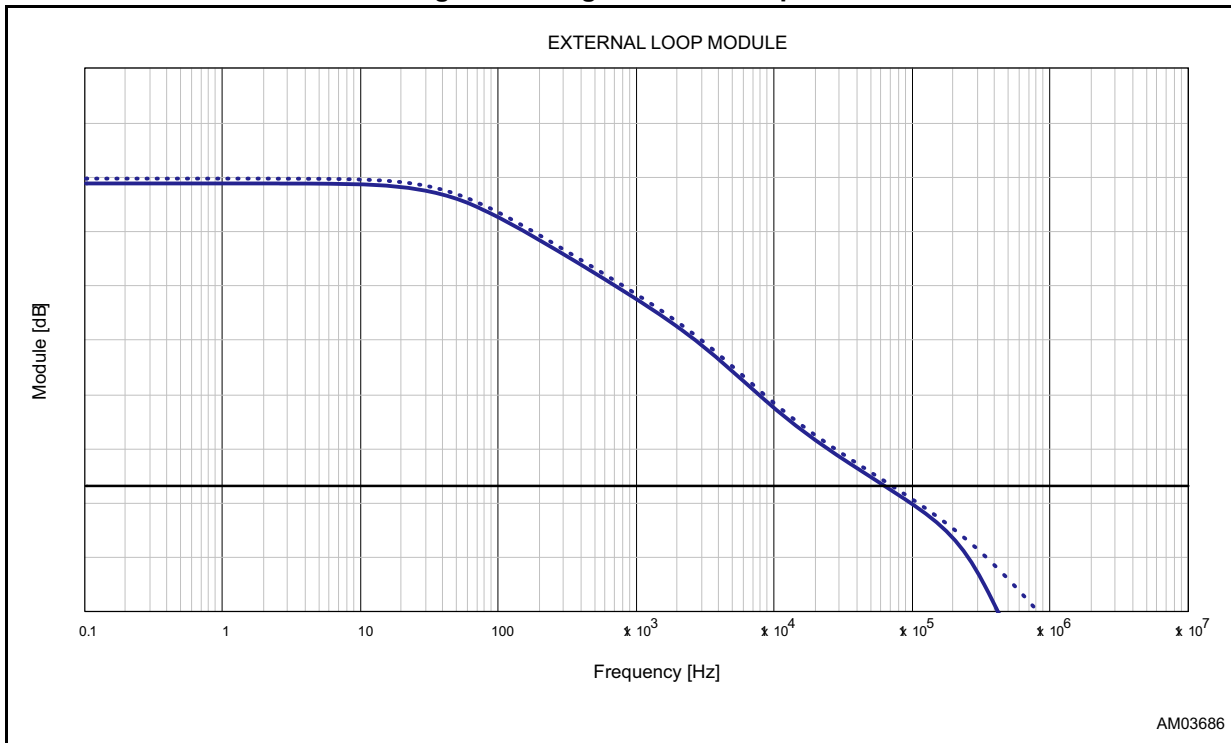

Figure 40. Phase margin Bode's plot

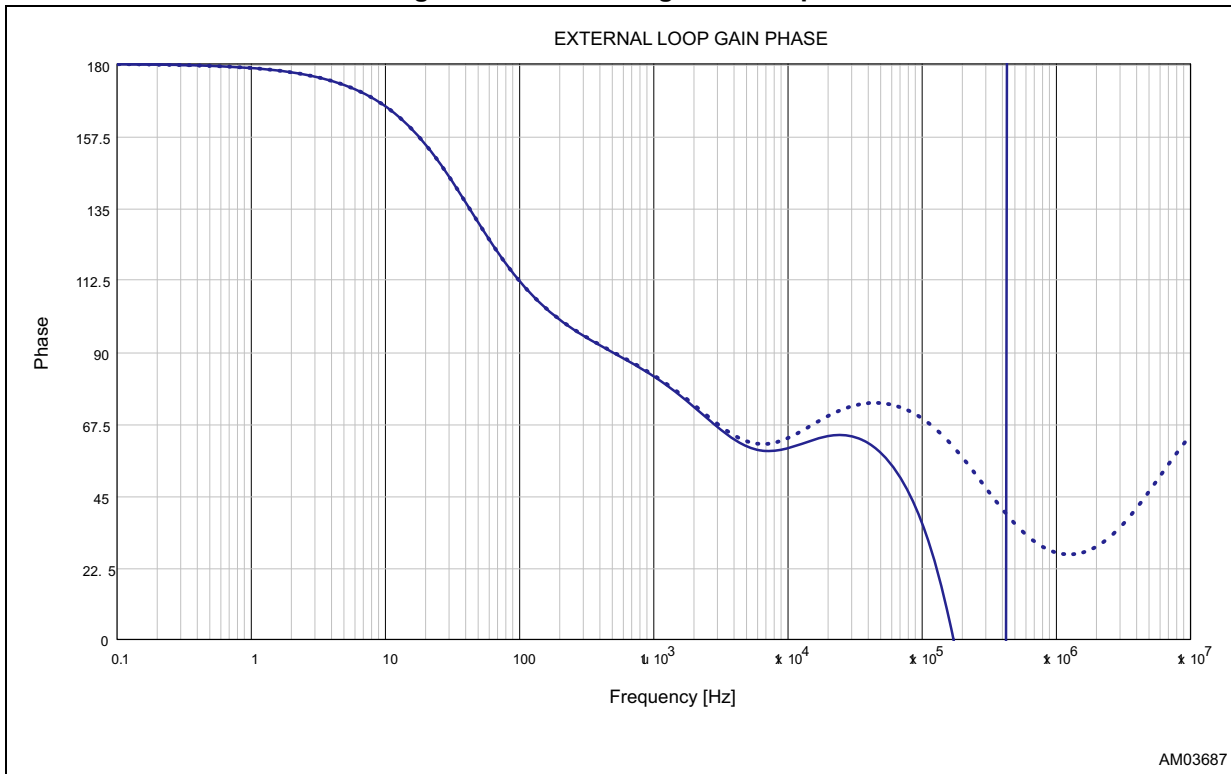

Figure 41. Top layer

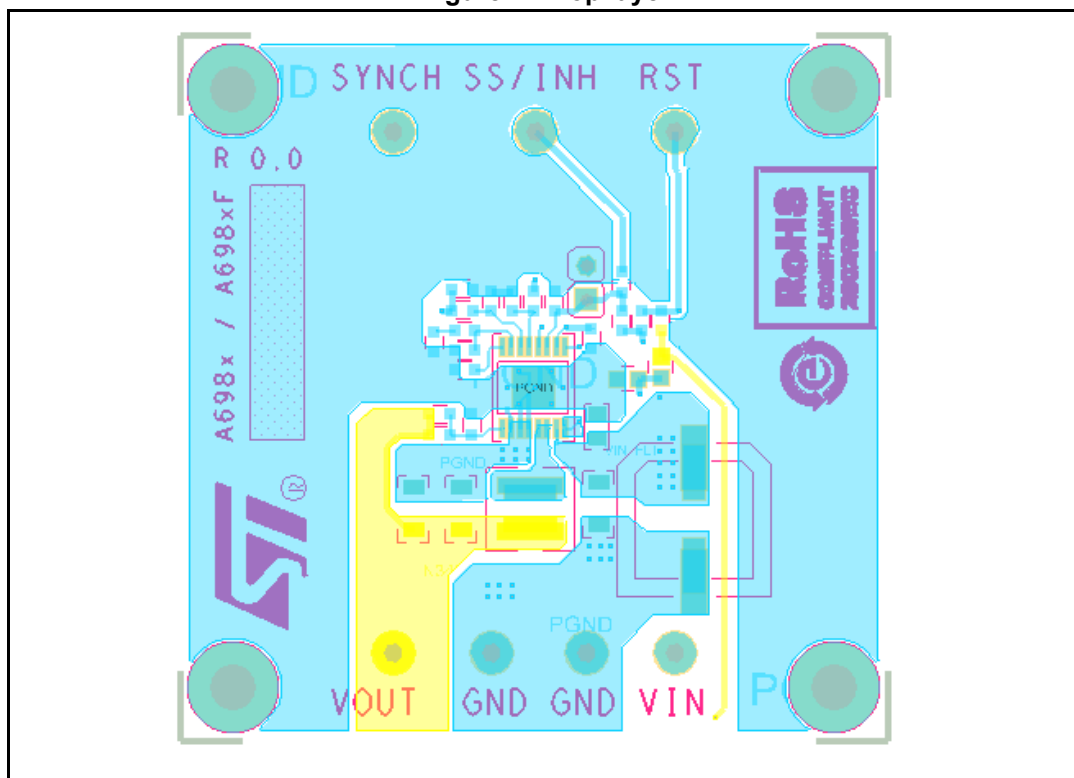
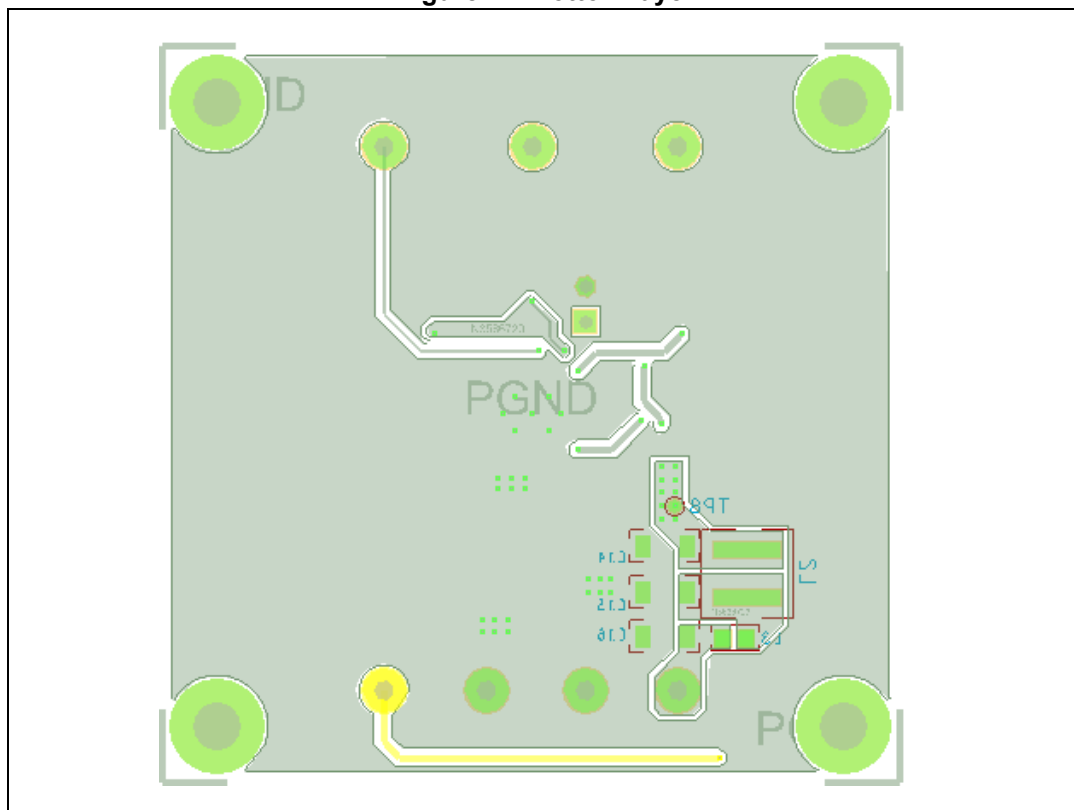

Figure 42. Bottom layer



8 Efficiency curves

Figure 43. Efficiency curves over f_{sw} : $V_{IN} = 13.5\text{ V} - V_{OUT} = 3.3\text{ V}$

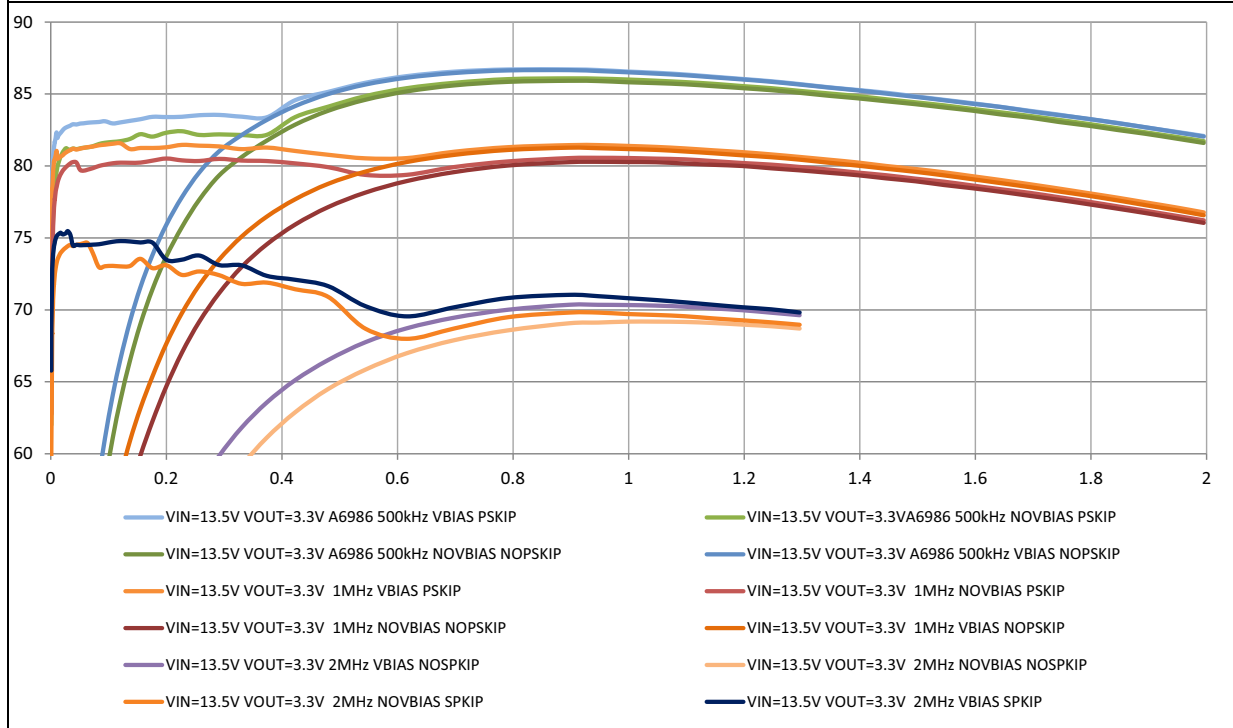

Figure 44. Efficiency curves over f_{sw} : $V_{IN} = 13.5\text{ V} - V_{OUT} = 3.3\text{ V}$ (log scale)

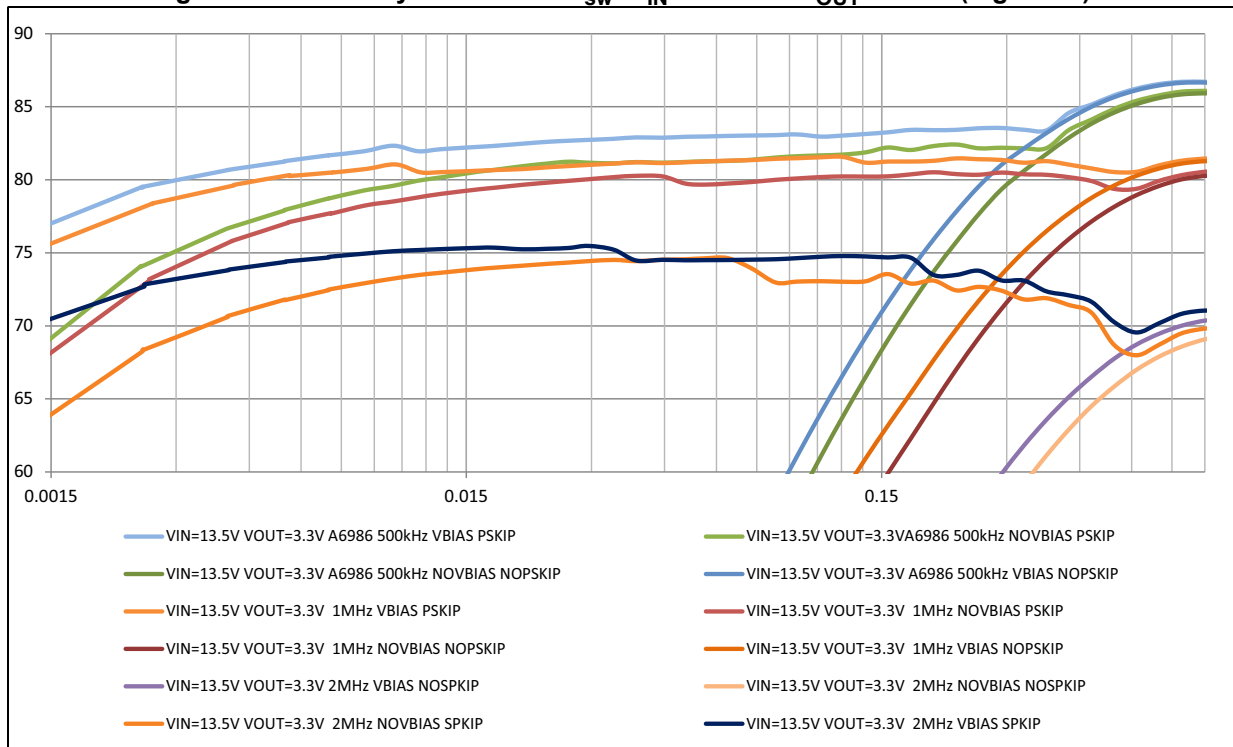

Figure 45. Efficiency curves over f_{sw} : $V_{IN} = 13.5\text{ V} - V_{OUT} = 5\text{ V}$

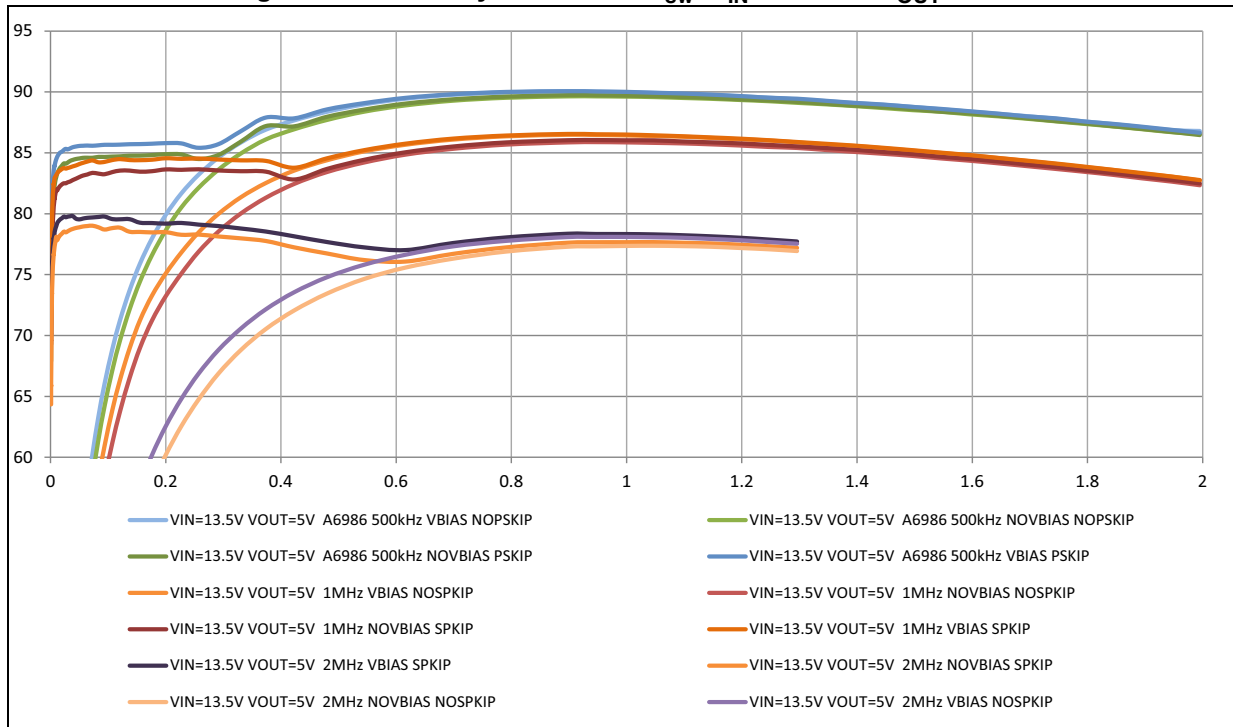

Figure 46. Efficiency curves over f_{sw} : $V_{IN} = 13.5\text{ V} - V_{OUT} = 5\text{ V}$ (log scale)

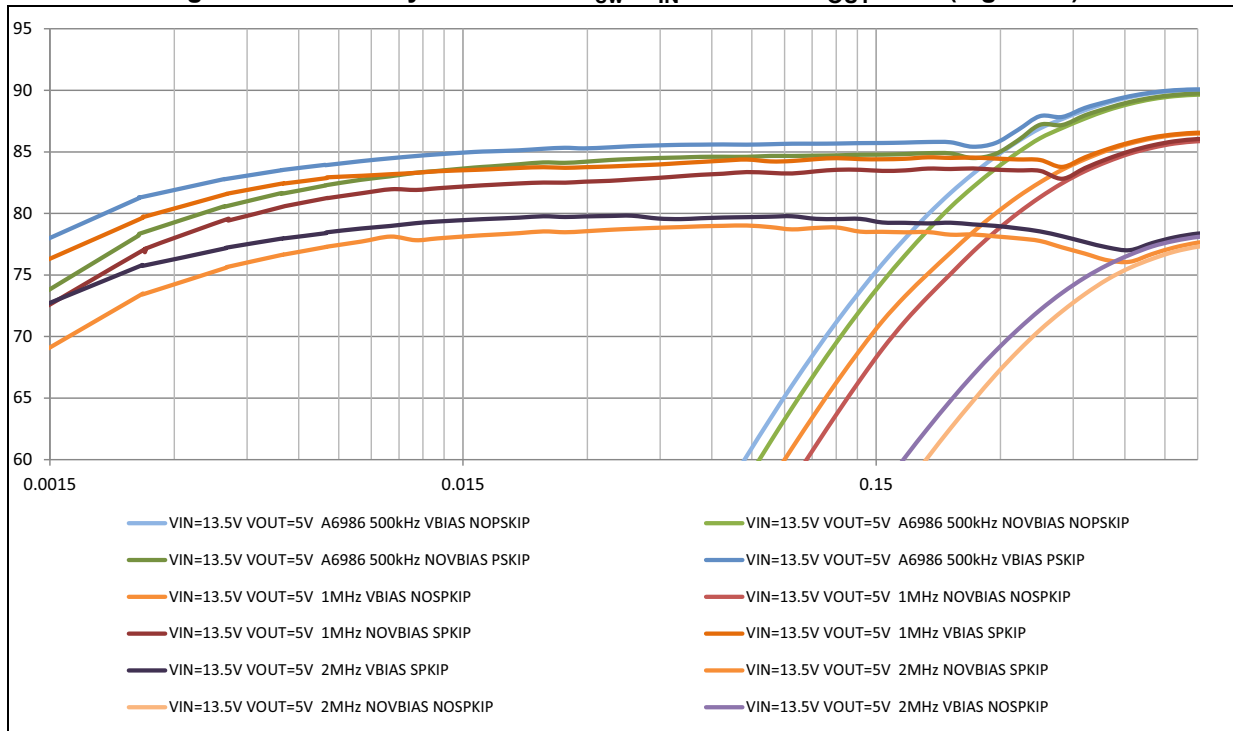

Figure 47. Efficiency curves over f_{sw} : $V_{IN} = 24\text{ V} - V_{OUT} = 3.3\text{ V}$

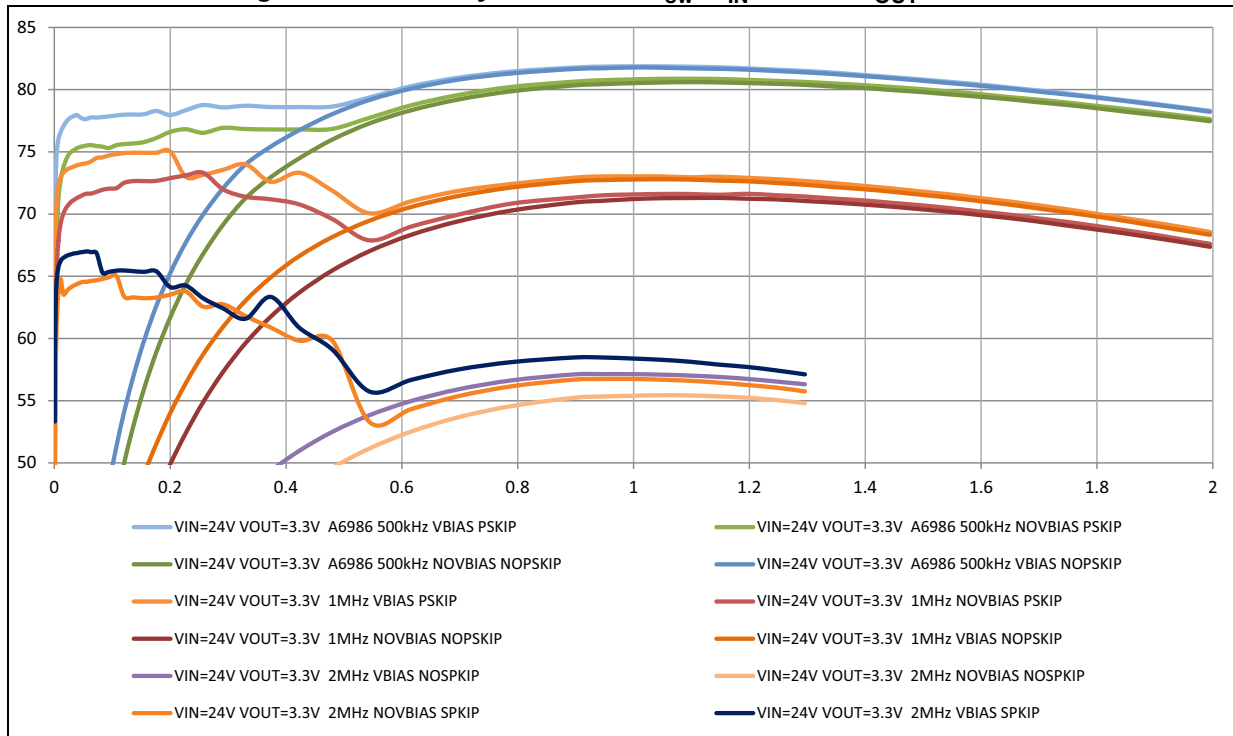

Figure 48. Efficiency curves over f_{sw} : $V_{IN} = 24\text{ V} - V_{OUT} = 3.3\text{ V}$ (log scale)

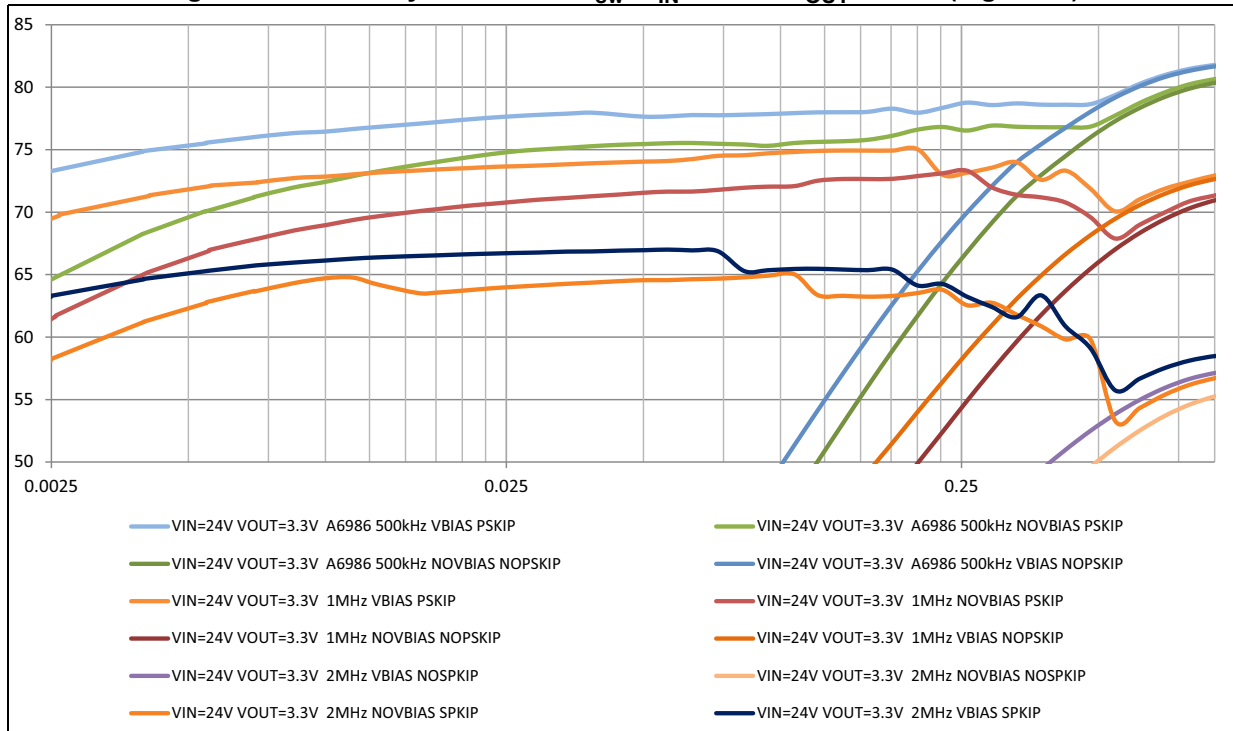

Figure 49. Efficiency curves over f_{sw} : $V_{IN} = 24\text{ V} - V_{OUT} = 5\text{ V}$

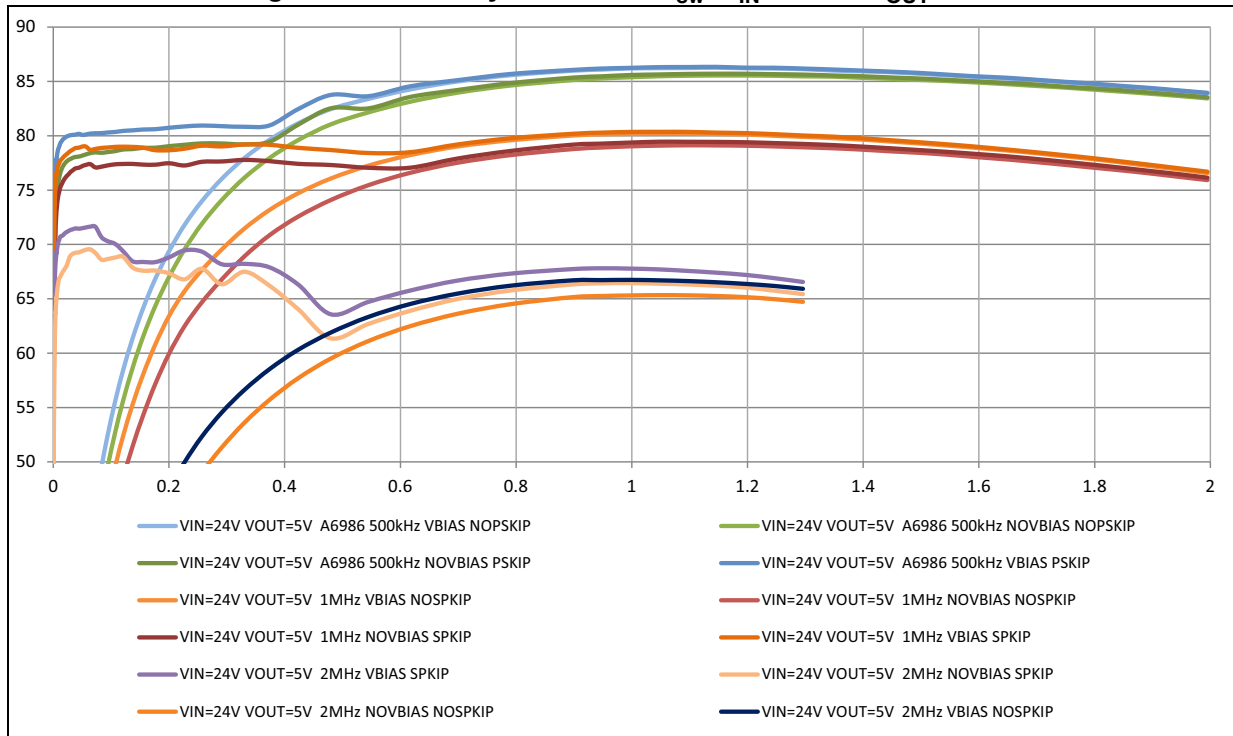

Figure 50. Efficiency curves over f_{sw} : $V_{IN} = 24\text{ V} - V_{OUT} = 5\text{ V}$ (log scale)

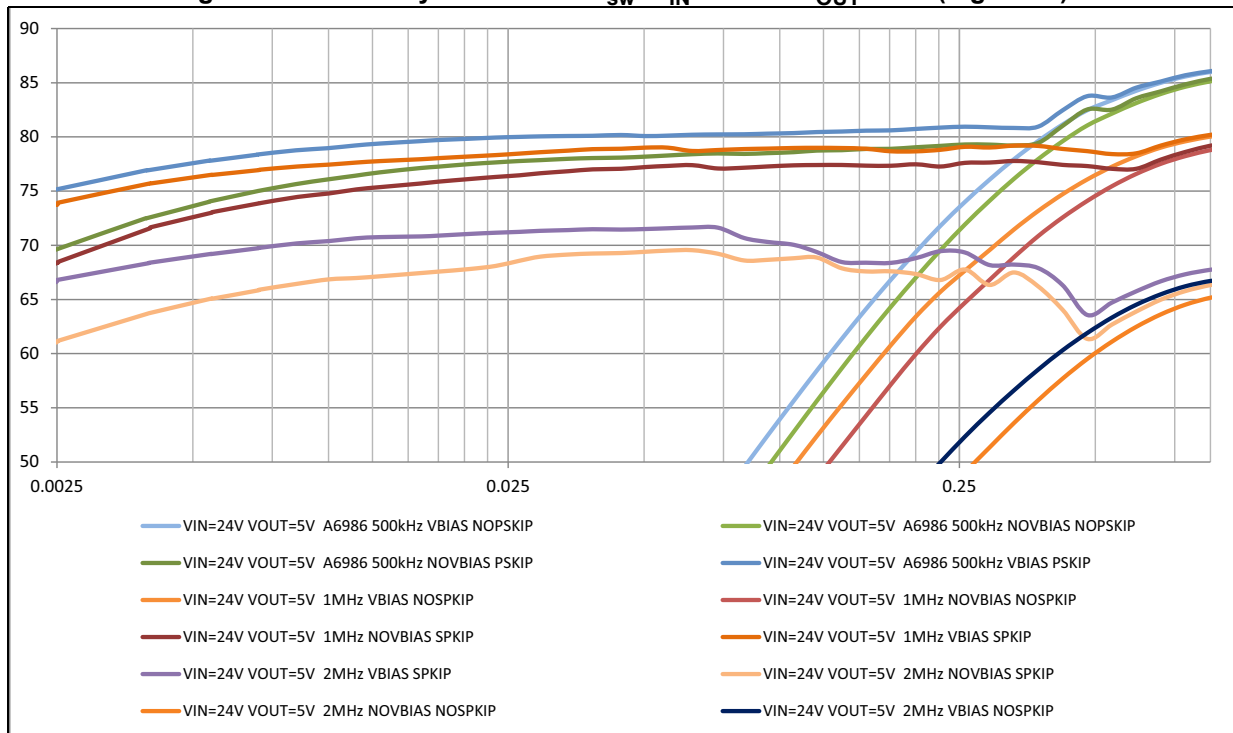

Figure 51. Efficiency curves: $f_{sw} = 500\text{kHz}$ - $V_{IN} = 24\text{ V}$ - $V_{OUT} = 3.3\text{ V}$

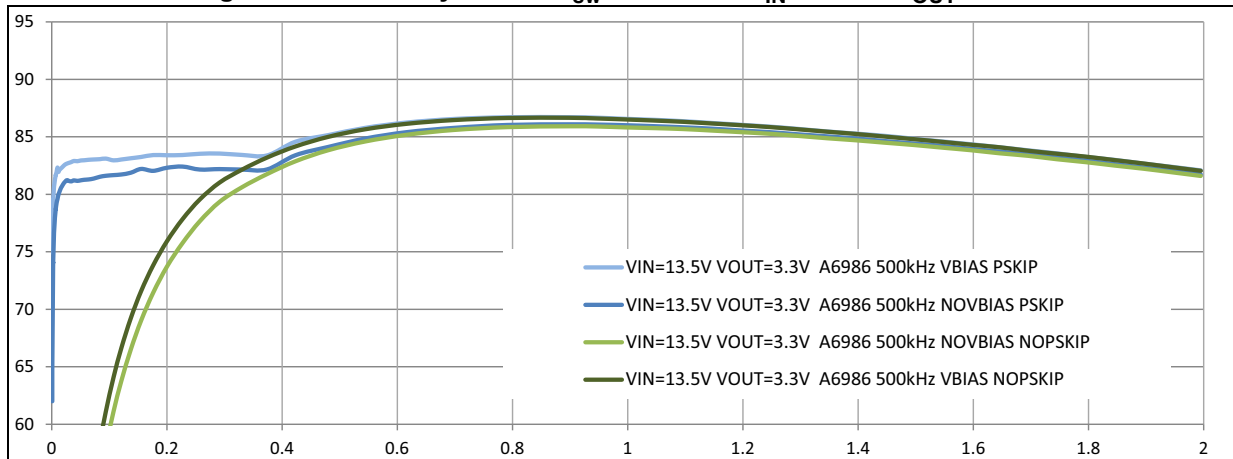

Figure 52. Efficiency curves: $f_{sw} = 500\text{ kHz}$ - $V_{IN} = 13.5\text{ V}$ - $V_{OUT} = 3.3\text{ V}$ (log scale)

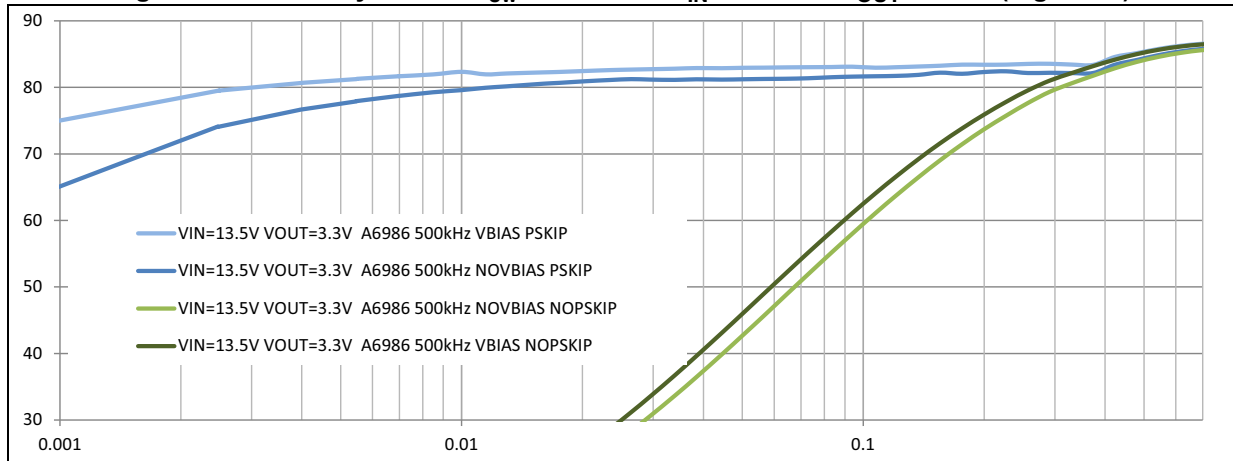

Figure 53. Efficiency curves: $f_{sw} = 500\text{ kHz}$ - $V_{IN} = 13.5\text{ V}$ - $V_{OUT} = 5\text{ V}$

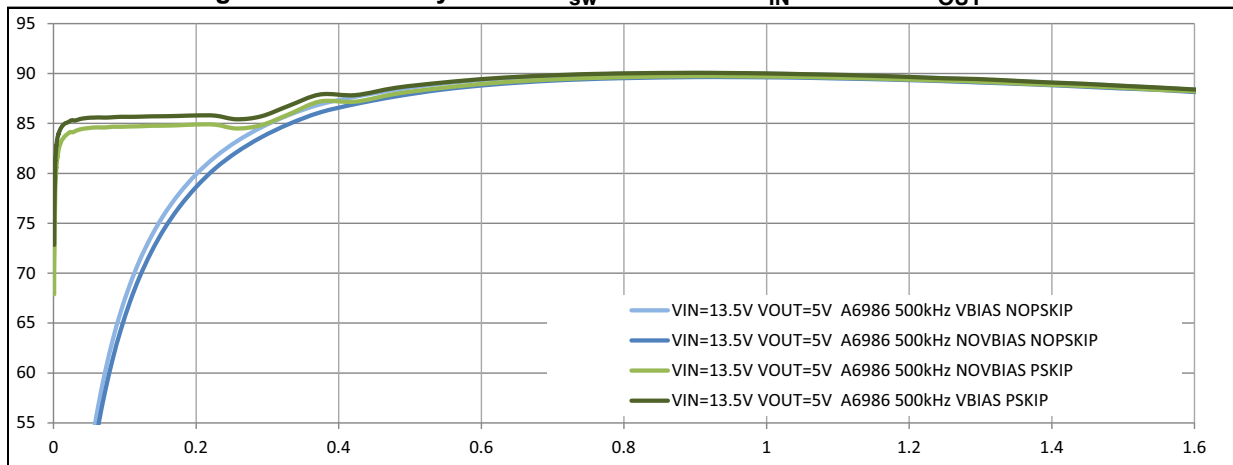

Figure 54. Efficiency curves: $f_{sw} = 500 \text{ kHz}$ - $V_{IN} = 13.5 \text{ V}$ - $V_{OUT} = 5 \text{ V}$ (log scale)

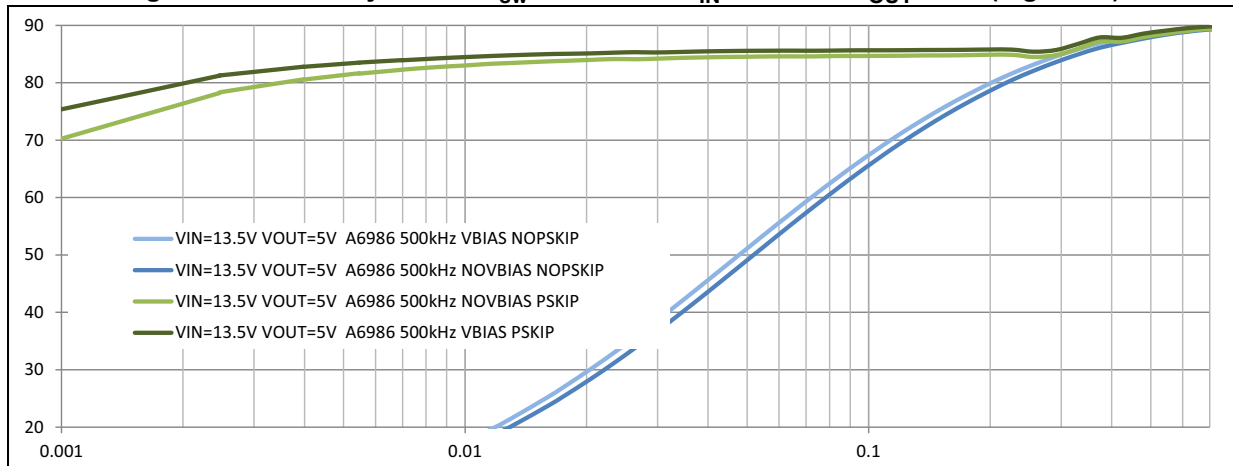

Figure 55. Efficiency curves: $f_{sw} = 500 \text{ kHz}$ - $V_{IN} = 24 \text{ V}$ - $V_{OUT} = 3.3 \text{ V}$

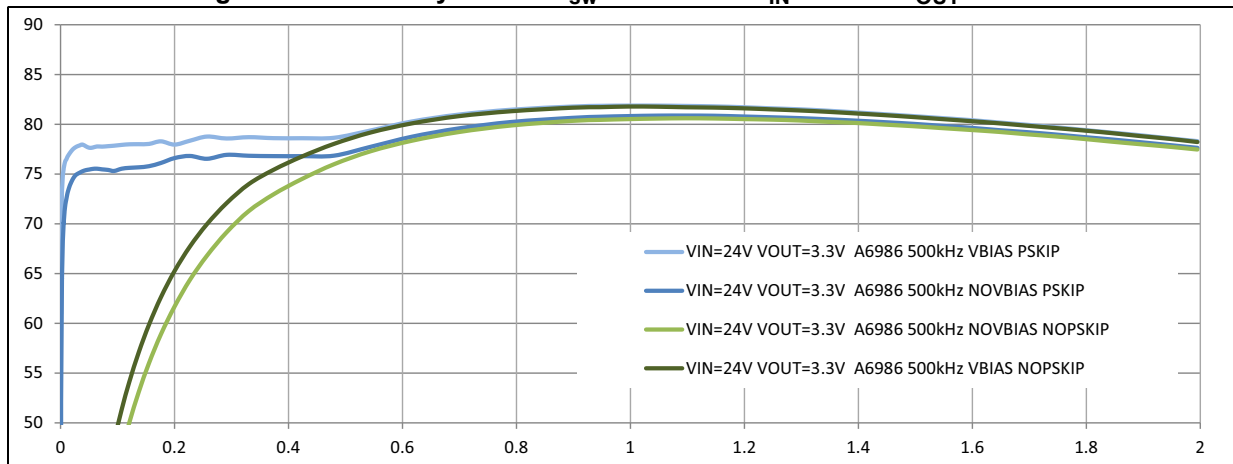

Figure 56. Efficiency curves: $f_{sw} = 500 \text{ kHz}$ - $V_{IN} = 24 \text{ V}$ - $V_{OUT} = 3.3 \text{ V}$ (log scale)

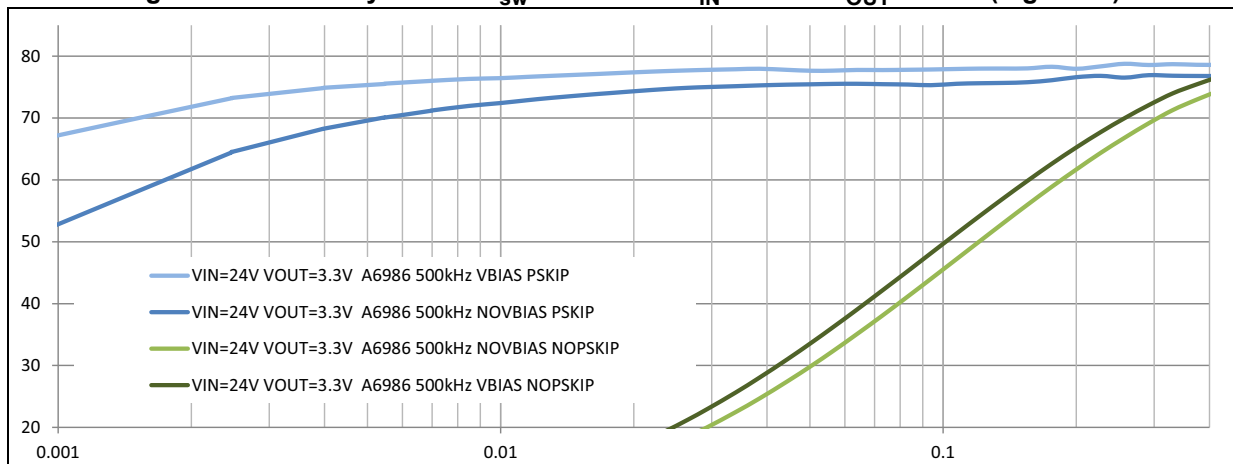

Figure 57. Efficiency curves: $f_{sw} = 500 \text{ kHz}$ - $V_{IN} = 24 \text{ V}$ - $V_{OUT} = 5 \text{ V}$ (log scale)

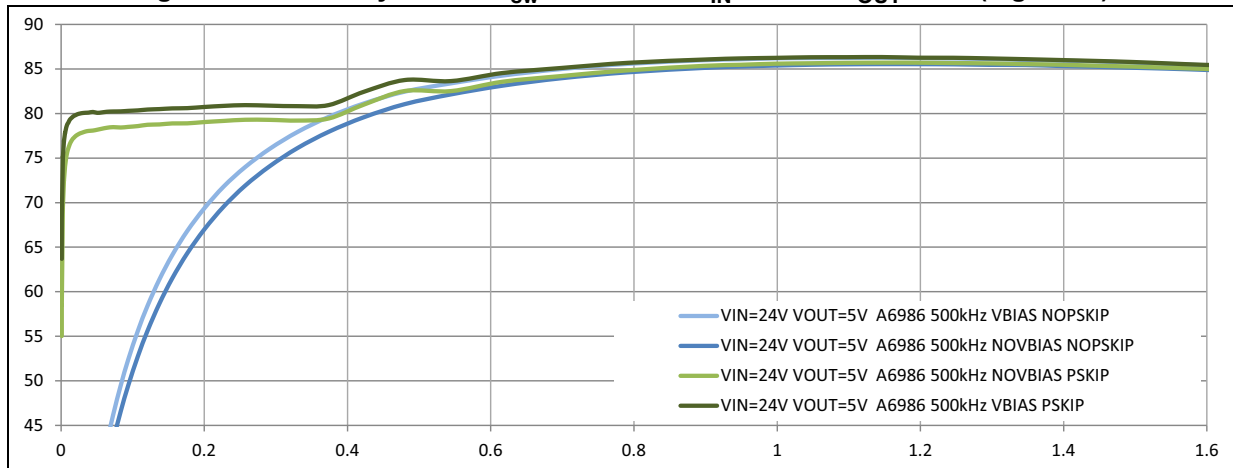
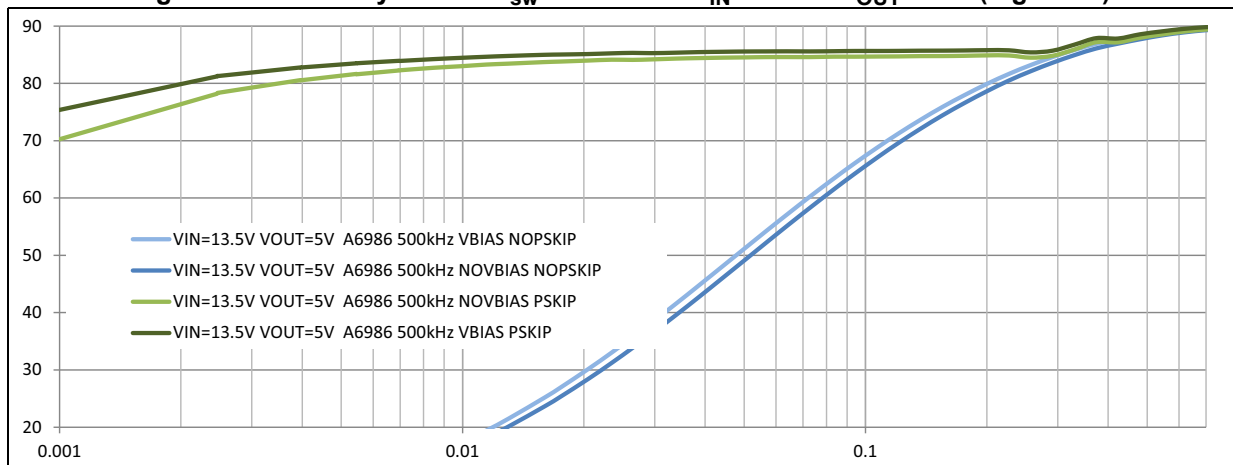

Figure 58. Efficiency curves: $f_{sw} = 500 \text{ kHz}$ - $V_{IN} = 13.5 \text{ V}$ - $V_{OUT} = 5 \text{ V}$ (log scale)



9 Package information

In order to meet environmental requirements, ST offers these devices in different grades of ECOPACK[®] packages, depending on their level of environmental compliance. ECOPACK specifications, grade definitions and product status are available at: www.st.com. ECOPACK is an ST trademark.

Figure 59. HTSSOP16 package outline

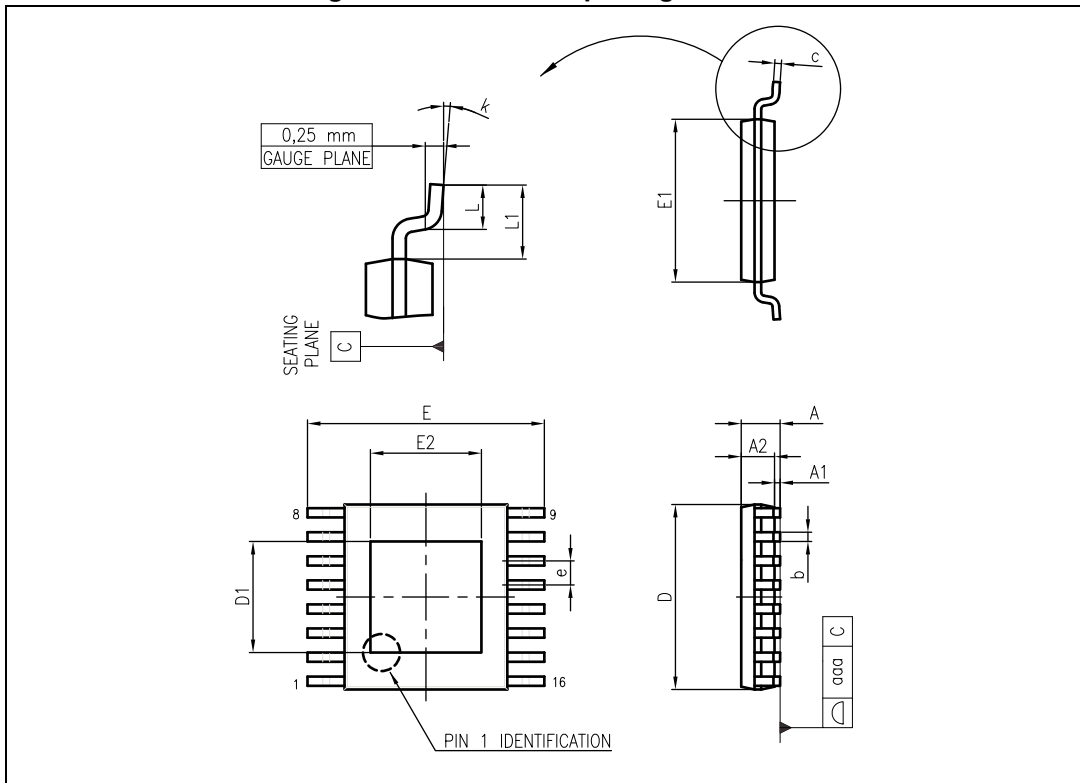

Table 14. HTSSOP16 package mechanical data

Symbol	Dimensions (mm)		
	Min.	Typ.	Max.
A			1.20
A1			0.15
A2	0.80	1.00	1.05
b	0.19		0.30
c	0.09		0.20
D	4.90	5.00	5.10
D1	2.8	3	3.2
E	6.20	6.40	6.60
E1	4.30	4.40	4.50
E2	2.8	3	3.2
e		0.65	
L	0.45	0.60	0.75
L1		1.00	
k	0.00		8.00
aaa			0.10

10 Order codes

Table 15. Order codes

Part numbers	Package	Packaging
L6986	HTSSOP16	Tube
L6986TR		Tape and reel

11 Revision history

Table 16. Document revision history

Date	Revision	Changes
11-Oct-2013	1	Initial release.
17-Mar-2014	2	Several modifications throughout document.
03-Apr-2014	3	Updated Section 3: Electrical characteristics (added sentence about testing above Table 7 on page 11). Updated Section 6.5: Synchronization (LNM) on page 43 (added "(LNM)" to title, updated 3 first paragraphs, updated second paragraph below Figure 33 on page 44). Updated cross-reference in Section 6.6.2: Inductor selection on page 49 . Added Section 10: Order codes on page 64 . Minor modifications throughout document.
22-Aug-2014	4	Updated Section : Features on page 1 (replaced 5 by 8 μA $I_{\text{Q-SHTDWN}}$). Updated Equation 17 on page 29 , Equation 18 on page 33 , Equation 20 on page 34 , Equation 34 on page 39 , Equation 44 on page 48 , Equation 47 on page 48 to Equation 49 on page 48 , Equation 51 on page 49 to Equation 54 on page 50 . Updated Section 5.1: G_{CO}(s) control to output transfer function on page 33 (replaced "R ₀ " by "R _{LOAD} " and "LC filter" by "power stage"). Updated Figure 24 on page 33 , Figure 25 on page 35 , and Figure 31 on page 43 . Added Section 8: Efficiency curves on page 55 .
23-Feb-2015		Updated Section : Features on page 1 (replaced 110 m Ω by 150 m Ω - R _{DSON LS}). Updated Section 4.3: Soft-start and inhibit on page 14 (added and updated text, added Figure 7 to Figure 9 , Equation 2 to Equation 11). Updated Section 6.5: Synchronization (LNM) on page 43 (added and updated text, Figure 31 , added Figure 34 to Figure 37 , Table 9). Minor modifications throughout document.

IMPORTANT NOTICE – PLEASE READ CAREFULLY

STMicroelectronics NV and its subsidiaries ("ST") reserve the right to make changes, corrections, enhancements, modifications, and improvements to ST products and/or to this document at any time without notice. Purchasers should obtain the latest relevant information on ST products before placing orders. ST products are sold pursuant to ST's terms and conditions of sale in place at the time of order acknowledgement.

Purchasers are solely responsible for the choice, selection, and use of ST products and ST assumes no liability for application assistance or the design of Purchasers' products.

No license, express or implied, to any intellectual property right is granted by ST herein.

Resale of ST products with provisions different from the information set forth herein shall void any warranty granted by ST for such product.

ST and the ST logo are trademarks of ST. All other product or service names are the property of their respective owners.

Information in this document supersedes and replaces information previously supplied in any prior versions of this document.

© 2015 STMicroelectronics – All rights reserved