

Datenblatt

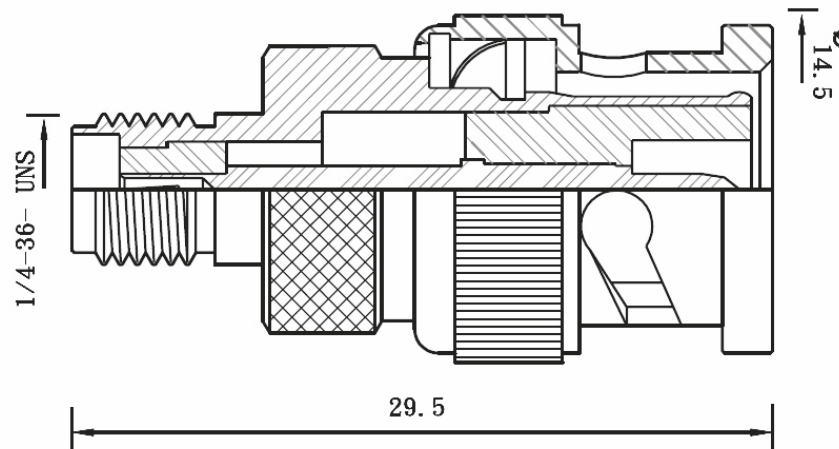

- NOTE: FINISH (PLATING THICKNESS IN MICRO-INCHES)
1. BODY: BRASS PER JIS-C3604
 2. CONTACT: PH/BRONZE PER ASTM B196 UNS C17300
 3. INSULATION: TEFLON PER ASTM D1457 AND ASTM D1710
 4. CONNECTOR INTERFACE PER MIL-STD-348A
 5. PART TO BE CLEAN AND FREE BURRS
 6. NICKEL PL 70 MIN THICK OVER COPPER STRIKE
 7. GOLD PL 3 MIN OVER NICKEL PL 70 MIN THICK OVER COPPER STRIKE

4	Shell	Brass	Nickel
3	Insulator	Teflon	White
2	Contact	Brass	Gold
1	Body	Brass	Nickel
No	Description	Material	Finish