

Total solder points: 63

Difficulty level: *beginner* 1  2  3  4  5  *advanced*

## 2 CHANNEL RF CODELOCK TRANSMITTER



# *K8059*

For use with K8057/VM109  
2 Channel RF receiver



**Features:**

- ☑ For use with the K8057/VM109 2-channel RF receivers.
- ☑ Generates unique 32-bit code.
- ☑ More than 1,000,000,000 unique codes.
- ☑ Code can easily be changed for safety purposes.
- ☑ Choose continuous or 'burst' transmission.
- ☑ LED indicator.
- ☑ Limited compatibility with K6706 - K6706A - K6706B/G

**Specifications:**

- Power supply: 12V battery V23GA, GP23GA,... (not incl.)
- 433MHz operation
- Open field range of up to 30m possible
- Dimensions: 63 x 40 x 16mm (2.5" x 1.6" x 0.6")

Velleman hereby certifies that the device K8059 meets the essential requirements and all other relevant stipulations of directive 1999/5/EG and 1995/5/EC.

For the complete conformity declaration check out :  
[Http://www.velleman.be/downloads/doC/CE\\_K8059.pdf](http://www.velleman.be/downloads/doC/CE_K8059.pdf)

### 1. Assembly (Skipping this can lead to troubles !)

Ok, so we have your attention. These hints will help you to make this project successful. Read them carefully.

#### 1.1 Make sure you have the right tools:

- A good quality soldering iron (25-40W) with a small tip.
- Wipe it often on a wet sponge or cloth, to keep it clean; then apply solder to the tip, to give it a wet look. This is called 'thinning' and will protect the tip, and enables you to make good connections. When solder rolls off the tip, it needs cleaning.
- Thin rosin-core solder. Do not use any flux or grease.
- A diagonal cutter to trim excess wires. To avoid injury when cutting excess leads, hold the lead so they cannot fly towards the eyes.
- Needle nose pliers, for bending leads, or to hold components in place.
- Small blade and Phillips screwdrivers. A basic range is fine.

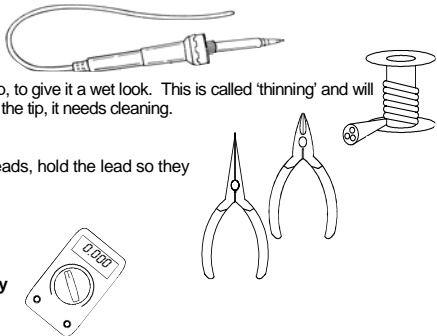

**For some projects, a basic multi-meter is required, or might be handy**

#### 1.2 Assembly Hints :

- ⇒ Make sure the skill level matches your experience, to avoid disappointments.
- ⇒ Follow the instructions carefully. Read and understand the entire step before you perform each operation.
- ⇒ Perform the assembly in the correct order as stated in this manual
- ⇒ Position all parts on the PCB (Printed Circuit Board) as shown on the drawings.
- ⇒ Values on the circuit diagram are subject to changes.
- ⇒ Values in this assembly guide are correct\*
- ⇒ Use the check-boxes to mark your progress.
- ⇒ Please read the included information on safety and customer service

\* Typographical inaccuracies excluded. Always look for possible last minute manual updates, indicated as 'NOTE' on a separate leaflet.

### 1.3 Soldering Hints :

1- Mount the component against the PCB surface and carefully solder the leads

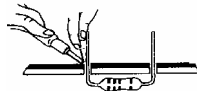

2- Make sure the solder joints are cone-shaped and shiny

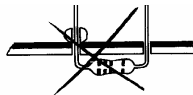
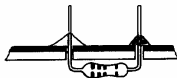

3- Trim excess leads as close as possible to the solder joint

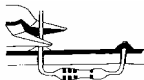

REMOVE THEM FROM THE TAPE ONE AT A TIME !

**AXIAL COMPONENTS ARE TAPED IN THE  
CORRECT MOUNTING SEQUENCE !**

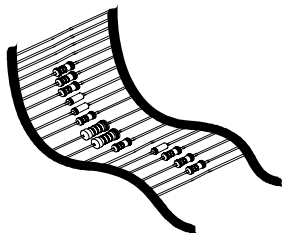

You will find the colour code for the resistances and the LEDs in the HALG (general manual) and on our website: <http://www.velleman.be/common/service.aspx>

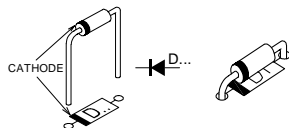
**1. Diodes. Watch the polarity!**

- D1 : BAT85
- D2 : BAT85

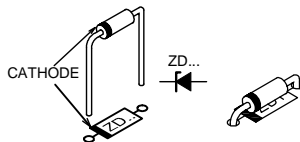
**2. Zenerdiode. Watch the polarity!**

- ZD1 : 5V1 / 500mW

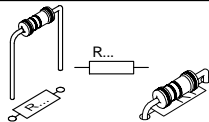
**3. 1/8W Resistors**

- R1 : 33K (3 - 3 - 3 - B)
- R2 : 33K (3 - 3 - 3 - B)
- R3 : 33K (3 - 3 - 3 - B)
- R4 : 47 (4 - 7 - 0 - B)
- R5 : 220 (2 - 2 - 1 - B)
- R6 : 2K7 (2 - 7 - 2 - B)

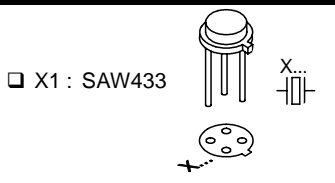
**4. SAW resonator**

- X1 : SAW433

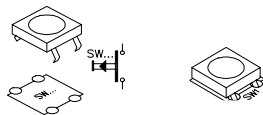
**5. Push buttons**

- SW1 : KRS0611
- SW2 : KRS0611
- SW3 : KRS0611

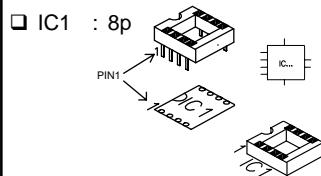
**6. IC socket. Pay attention to the position of the notch!**

- IC1 : 8p

## 7. Battery contacts

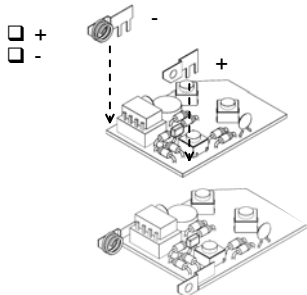

☞ Check for good attachment of the solder to the contacts

## 8. LED

☐ LD1 : 3mm blue

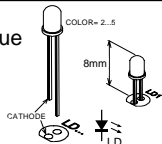

## 9. Capacitors

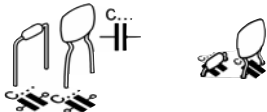

- ☐ C1 : 1pF (red 1)
- ☐ C2 : 4p7 (black, 4.7)
- ☐ C3 : 100pF (101)

☞ Bend C3 away from the IR-LED

- ☐ C4 : 100pF (101)
- ☐ C5 : 100pF (101)
- ☐ C6 : 100nF (104)

## 10. Transistor

☐ T1 : MPSH10

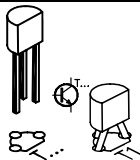

## 11. IC. Pay attention to the notch !

☐ IC1 : VK8059

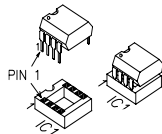

VK8059=(Programmed PIC12F629)

☞ Pay attention to the position of the notch!

## 12. Sticker

Affix the supplied sticker to the back of the housing.



## 13. Use

The transmitter comes with a factory set default code. However, for security reasons, it might be wise not to use the default code.

### 1. To program your unique code :

- Hold SW1(\*) (left button).
- Briefly press the 'program'-button (SW3) 3 times. The LED will flash 3 times.
- Release SW1.
- Your unique 32-bit code has been generated and stored.

(\*If you hold SW2 (right button) instead of SW1 (left button), the unit will generate and store your unique 32-bit code and the transmitter will be configured in such a way that continuous transmission is not possible i.e. if you hold either button transmission will stop after a +/- 1s)

### 2. To return to the default code :

- Hold SW1 (left button).
- Hold the 'program'-button (SW3).
- After +/- 10s the led will flash 5 times.
- Release both buttons.
- Your code has been erased.

 To set a new code, see point 1.



**3. Compatibility with previous transmitters (K6706 - K6706A - K6706B - K6706G) :**

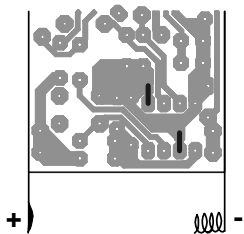

UM3758  
No code

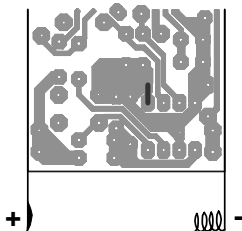

UM3758  
Pin1 -

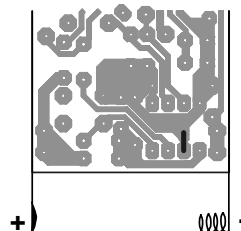

UM3758  
Pin1 +

## 14. Schematic diagram.

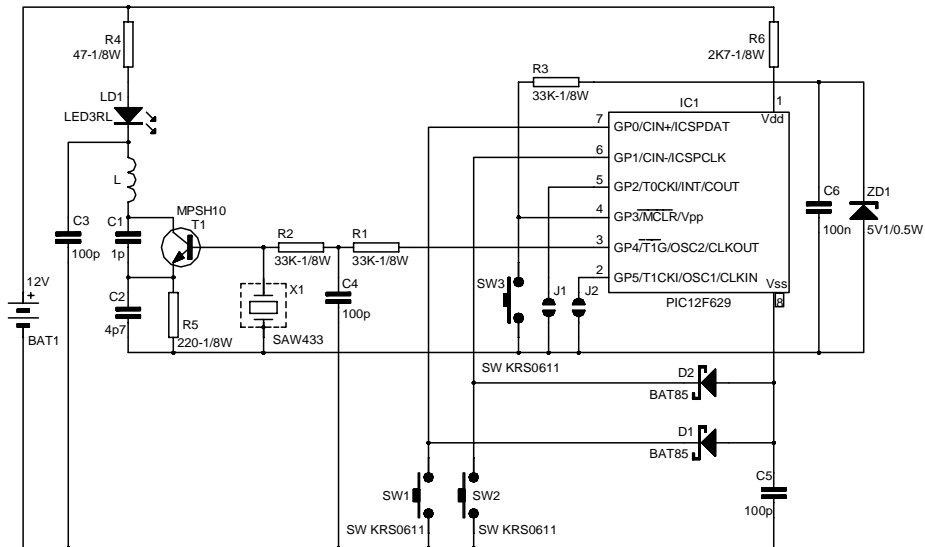

15. PCB

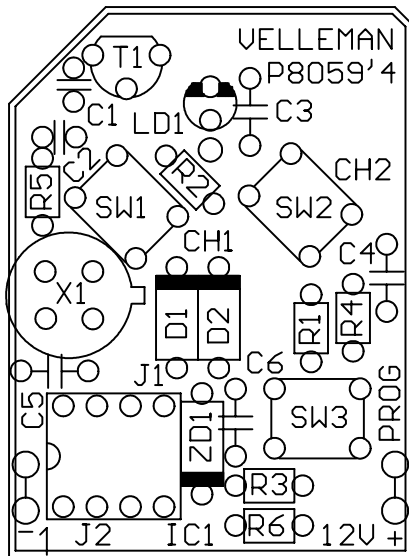



Modifications and typographical errors reserved  
© Velleman Components nv.  
H8059IP - 2004 - ED1

