

**HRTR 55 Ex**

**Diffuse reflection light scanner with background suppression**

en 02-2017/02 50113748-01



**5 ... 400mm**  
200mm with  
black-white error < 10%



- Diffuse reflection light scanner with visible red light and adjustable background suppression
- Stainless steel device housing and protective housing
- Exact scanning range adjustment through 8-turn potentiometer
- Very good black/white behavior and reliable switching nearly independent of the object or background properties
- Fast alignment through *brightVision*®
- A²LS- Active Ambient Light Suppression
- Certification
  - ⊕ II 3G Ex nA op is IIB T4 Gc X
  - ⊕ II 3D Ex tc IIIC T70°C Dc IP67 X

We reserve the right to make changes • PAL\_HRTR55\_Ex\_en\_50113748\_01.fm



**Accessories:**

(available separately)

- Cables with M8 connector



**Attention!**

Only use cables with axial (straight) plug outlet (see dimensioned drawing).

**Dimensioned drawing**

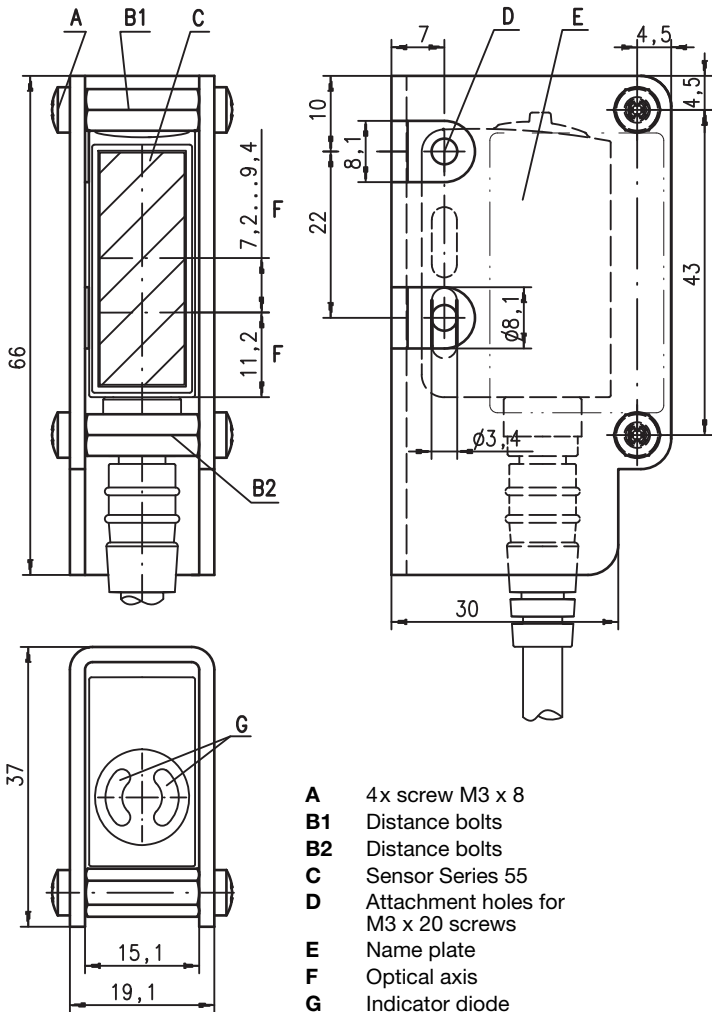

**Electrical connection**

Plug connection, 4-pin

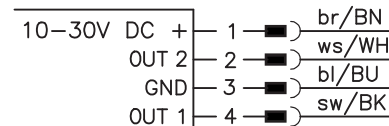

**DANGER**

- Observe the notices for installation and commissioning!
- Do not disconnect the sensor connection within the potentially explosive area while under voltage!

**Specifications**

**Optical data**

Typ. scanning range limit <sup>1)</sup> 5 ... 400mm  
 Scanning range <sup>2)</sup> see tables  
 Adjustment range 15 ... 400mm  
 Light beam characteristic focussed at 200mm  
 Light source <sup>3)</sup> LED (modulated light)  
 Wavelength 620nm (visible red light)

**Timing**

Switching frequency 1000Hz  
 Response time 0.5ms  
 Delay before start-up ≤ 300ms (acc. to. IEC 60947-5-2)

**Electrical data**

Operating voltage  $U_B$  10 ... 30VDC (incl. residual ripple)  
 Residual ripple ≤ 15% of  $U_B$   
 Open-circuit current ≤ 15mA  
 Switching output .../66 <sup>4)</sup> 2 push-pull switching outputs  
 pin 2: PNP dark switching, NPN light switching  
 pin 4: PNP light switching, NPN dark switching  
 light/dark switching  
 Function characteristics  $\geq (U_B - 2V) / \leq 2V$   
 Signal voltage high/low max. 100mA  
 Output current adjustable via 8-turn potentiometer  
 Scanning range

**Indicators**

Green LED ready  
 Yellow LED object detected - reflection

**Mechanical data**

Housing AISI 316L stainless steel, DIN X2CrNiMo17132, W.No 1.4404  
 Protective housing stainless steel AISI 303, DIN X8CrNiS18-9, W.Nr 1.4305  
 Optics cover coated plastic (PMMA), scratch resistant and non-diffusive  
 Operation plastic (TPV - PE), non-diffusive  
 Weight with M8 connector: 130g  
 Connection type M8 connector 4-pin

**Environmental data**

Ambient temp. (operation/storage) -20°C ... +50°C / -30°C ... +70°C  
 Protective circuit <sup>5)</sup> 2, 3  
 VDE safety class <sup>6)</sup> III  
 Protection class IP 67  
 Light source free group (in accordance with EN 62471)  
 Standards applied IEC 60947-5-2

**Explosion protection**

Labeling (CENELEC)  $\text{Ex}$  II 3G Ex nA op is IIB T4 Gc X  
 $\text{Ex}$  II 3D Ex tc IIIC T70 °C Dc IP67 X

- 1) Typ. scan. range limit: max. achievable scanning range for light objects (white 90%)
- 2) Scanning range: recommended scanning range for objects with different diffuse reflection
- 3) Average life expectancy 100,000h at an ambient temperature of 25°C
- 4) The push-pull switching outputs must not be connected in parallel
- 5) 2=polarity reversal protection, 3=short-circuit protection for all transistor outputs
- 6) Rating voltage 50V

**Tables**

1	5	400
2	10	300
3	15	200

1	white 90%
2	gray 18%
3	black 6%

Scanning range [mm]

**Diagrams**

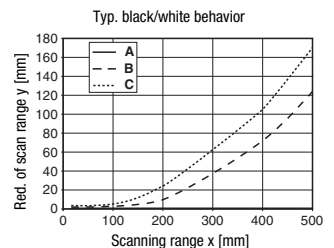
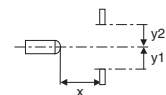
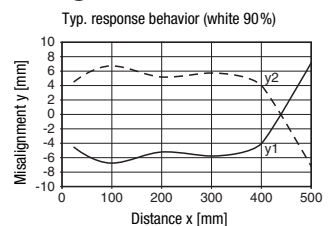

- A white 90%
- B gray 18%
- C black 6%

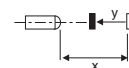

**Order guide**

	Designation	Part No.
with M8 connector	HRTR 55/66-S8 Ex	50115269

**Remarks**

**Operate in accordance with intended use!**

- ⚠ This product is not a safety sensor and is not intended as personnel protection.
- ⚠ The product may only be put into operation by competent persons.
- ⚠ Only use the product in accordance with the intended use.

- A list of tested chemicals can be found in the first part of the product description.

## Notices for the safe use of sensors in potentially explosive areas

This document is valid for devices with the following classifications:

Device group	Device category	Equipment protection level	Zone
II	3G	Gc	Zone 2
II	3D	Dc	Zone 22



### Attention!

- Check whether the equipment classification corresponds to the requirements of the application.
- The devices are not suited for the protection of persons and may not be used for emergency shutdown purposes.
- A safe operation is only possible if the equipment is used properly and for its intended purpose.
- Electrical equipment may endanger humans and (where applicable) animal health, and may threaten the safety of goods if used incorrectly or under unfavorable conditions in potentially explosive areas.
- The applicable national regulations (e.g. EN 60079-14) for the configuration and installation of explosion-proof systems must be observed without fail.

### Installation and Commissioning

- The devices must only be installed and commissioned by trained electricians. They must be aware of the regulations and operation of explosion-proof equipment.
- To prevent unintentional separation under voltage, devices with connector (e.g. Series 46B) must be equipped with a safeguard or a mechanical interlocking guard (e.g. K-VM12-Ex, part no. 50109217). The warning sign "Do not disconnect under voltage" that is supplied with the device must be attached to the sensor or its mounting bracket so that it is clearly visible.
- Devices with terminal compartment lid (e.g. Series 96) must only be commissioned if the terminal compartment lid of the device is properly sealed.
- Connection cables and connectors must be protected from excessive or unintended pulling or pushing strain.
- Prevent dust deposits from forming on the devices.
- Metallic parts (e.g. housing, mounting devices) are to be integrated into the potential equalization to prevent electrostatic charge.

### Maintenance

- No changes may be made to explosion-proof devices.
- Repairs may only be performed by a person trained for such work or by the manufacturer.
- Defective devices must be replaced immediately.
- Cyclical maintenance is generally not necessary.
- Depending on the environmental conditions, it may occasionally be necessary to clean the optical surfaces of the sensors. This cleaning must only be performed by persons trained for this task. We recommend using a soft, damp cloth. Cleaning agents that contain solvents must not be used.

### Chemical resistance

- The sensors demonstrate good resistance against diluted (weak) acids and bases.
- Exposure to organic solvents is possible only under certain circumstances and only for short periods of time.
- Resistance to chemicals must be examined on a case by case basis.

### Special conditions

- The sensor must be removed from the protective housing in order to connect the M8 connector. After the connection has been established, the sensor must be installed back into the protective housing properly. Operation without protective housing is not permitted.
- If the sensor is connected to the M8 connector and installed properly in the protective housing, the connector can no longer be unintentionally separated. Further mechanical protective measures are therefore not necessary.
- The devices must be installed in such a way that they are protected from direct exposure to UV rays (sunlight).

## Application notes



- For glossy surfaces (e.g. metals), the light beam should not be incident on the object surface at a right angle. A slight inclination is sufficient for preventing undesired direct reflections. This may result in a reduction in the scanning range.
- Objects should only be moved in laterally from the right or left. Moving in objects from the connector side or operating side is to be avoided.
- Outside of the scanning range, the sensor operates as an energetic diffuse reflection light scanner. Light objects can still be reliably detected up to the scanning range limit.
- The sensors are equipped with effective measures for the maximum avoidance of mutual interference should they be mounted opposite one another. Opposite mounting of multiple sensors of the same type should, however, absolutely be avoided.

**Mounting instructions**

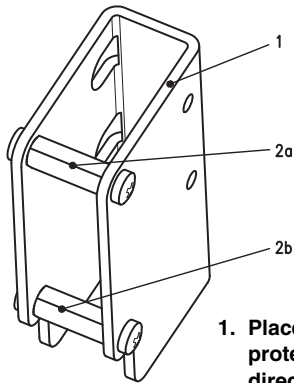

**1. Place device in the protective housing in the direction of the arrow.**

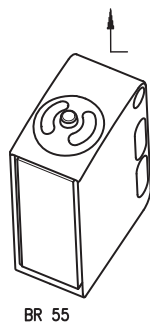

BR 55

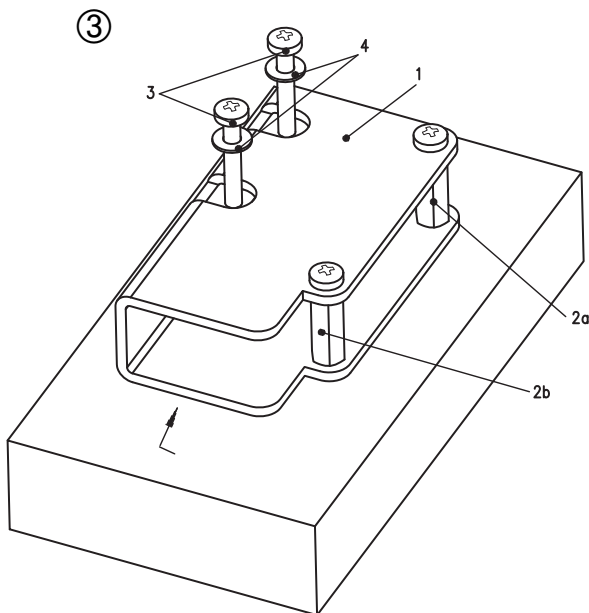
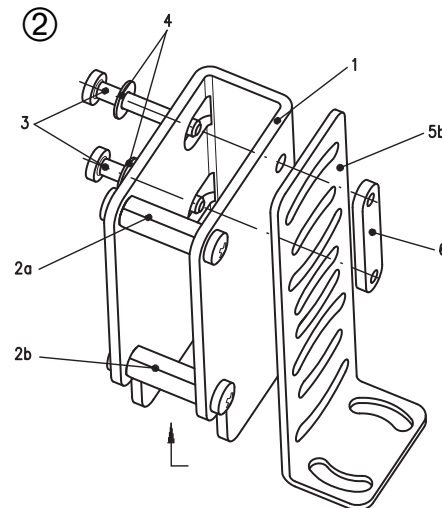
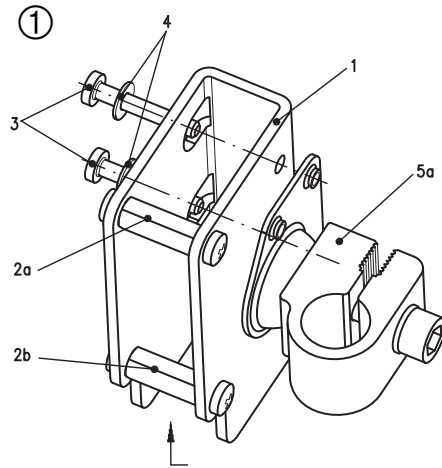

**2. Fit fastening screws (item 3) with washers (item 4) according to diagrams ①, ②, ③ depending on the installation situation, push through the device and securely tighten.**

- 1** Protective housing
- 2a, 2b** Distance bolts (mounted)
- 3** Screw M3
- 4** Washer
- 5a, 5b** Mounting devices (e.g. UMS 25, BT 25, ...)
- 6** Plate BT 3

