

DO NOT SCALE DRAWING

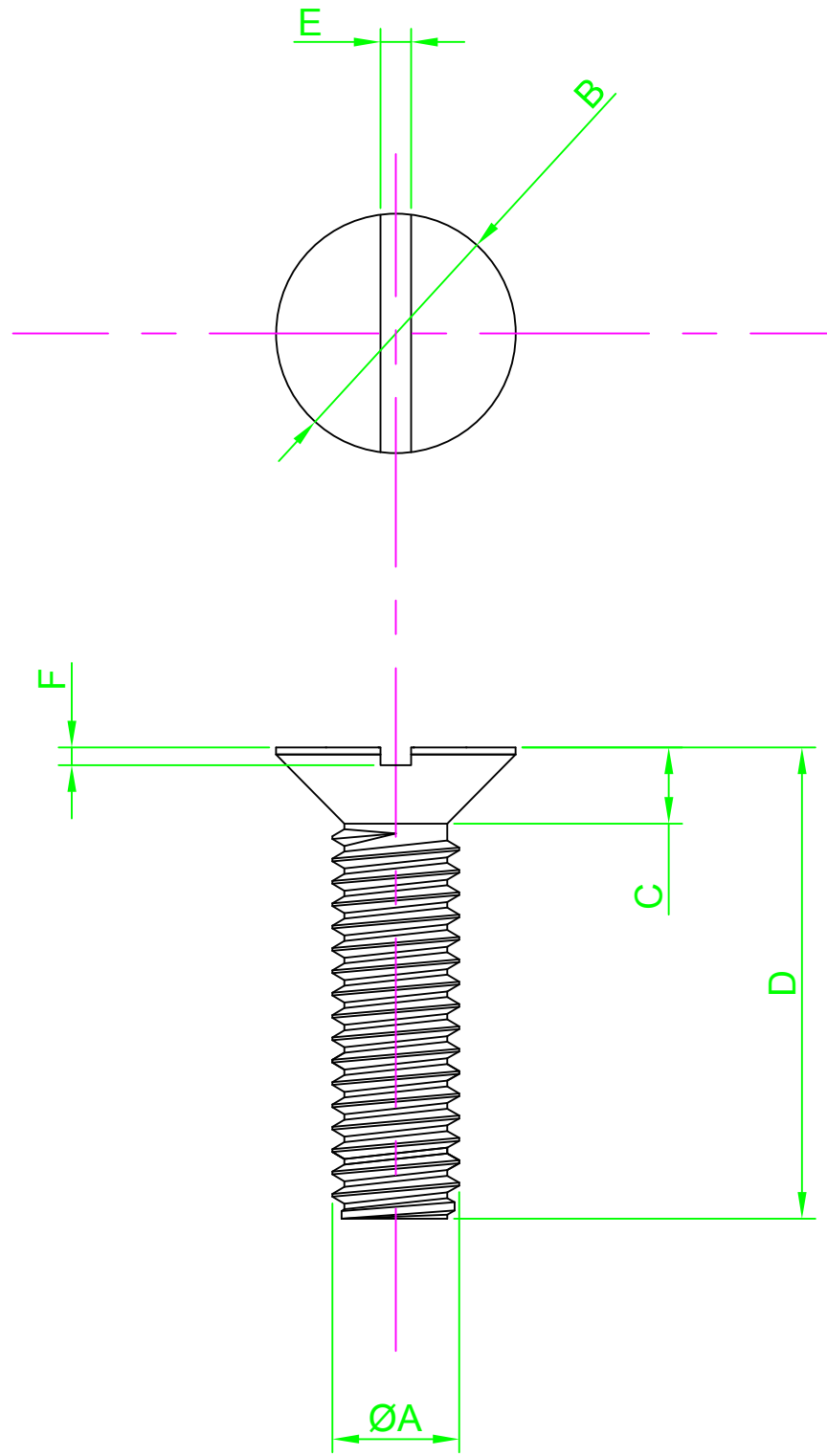
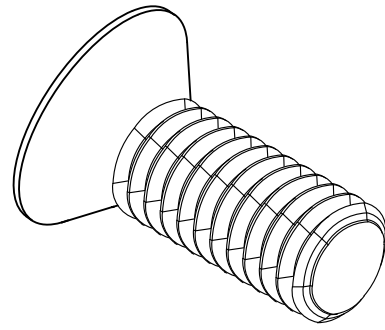

Part Number	ØA	B Nom	C Max	D Length	E Nom	F Max
M2.5 6 KSSTMC Z100	M2.5-0.45	4.7	1.5	6	0.6	0.7
M2.5 10 KSSTMC Z100				10		
M2.5 12 KSSTMC Z100				12		
M2.5 20 KSSTMC Z100				20		
M3 6 KSSTMC Z100	M3-0.5	5.6	1.65	6	0.8	0.85
M3 10 KSSTMC Z100				10		
M3 12 KSSTMC Z100				12		
M3 16 KSSTMC Z100				16		
M3 20 KSSTMC Z100				20		
M3 25 KSSTMC Z100	25					
M3.5 6 KSSTMC Z100	M3.5-0.6	6.5	1.93	6	0.8	1.0
M3.5 10 KSSTMC Z100				10		
M3.5 12 KSSTMC Z100				12		
M3.5 16 KSSTMC Z100				16		
M3.5 20 KSSTMC Z100				20		
M3.5 25 KSSTMC Z100	25					
M4 6 KSSTMC Z100	M4-0.7	7.5	2.2	6	1.0	1.1
M4 8 KSSTMC Z100				8		
M4 10 KSSTMC Z100				10		
M4 12 KSSTMC Z100				12		
M4 16 KSSTMC Z100				16		
M4 20 KSSTMC Z100				20		
M4 25 KSSTMC Z100				25		
M4 30 KSSTMC Z100				30		
M4 40 KSSTMC Z100				40		
M5 10 KSSTMC Z100				M5-0.8		
M5 12 KSSTMC Z100	12					
M5 20 KSSTMC Z100	20					
M5 25 KSSTMC Z100	25					
M5 40 KSSTMC Z100	40					
M6 10 KSSTMC Z100	M6-1.0	11.0	3.0	10	1.6	1.6
M6 12 KSSTMC Z100				12		

REVISION

A INITIAL DRAWING 21.9.15

NOTES:



UNLESS OTHERWISE SPECIFIED:
DIMENSIONS ARE IN MM (MILLIMETERS).
SURFACE FINISH:
TOLERANCES: DIN 963

MATERIAL:
Steel

TITLE:
Slotted Csk Head Machine Screw DIN 963

NAME	DATE
DRAWN Darryl Wilson	21.09.15
CHK'D	
APPVD	

HEAT TREATMENT:
N/A

DESIGN RIGHT. TR FASTENINGS LTD, 2003
UNDER NO CIRCUMSTANCES MUST THIS
DRAWING BE COPIED OR DISCLOSED
WITHOUT FIRST OBTAINING WRITTEN
AUTHORITY.

CUSTOMER PART NUMBER:
N/A

FINISH:
TC1 - Commercial Zinc/Clear Trivalent

DRAWING NUMBER:
TR32KSSTMC

A4

