

Customer Information Sheet

DRAWING No.: H9020-01 TO H9021-01

IF IN DOUBT - ASK

©

NOT TO SCALE

THIRD ANGLE PROJECTION

ALL DIMENSIONS IN mm

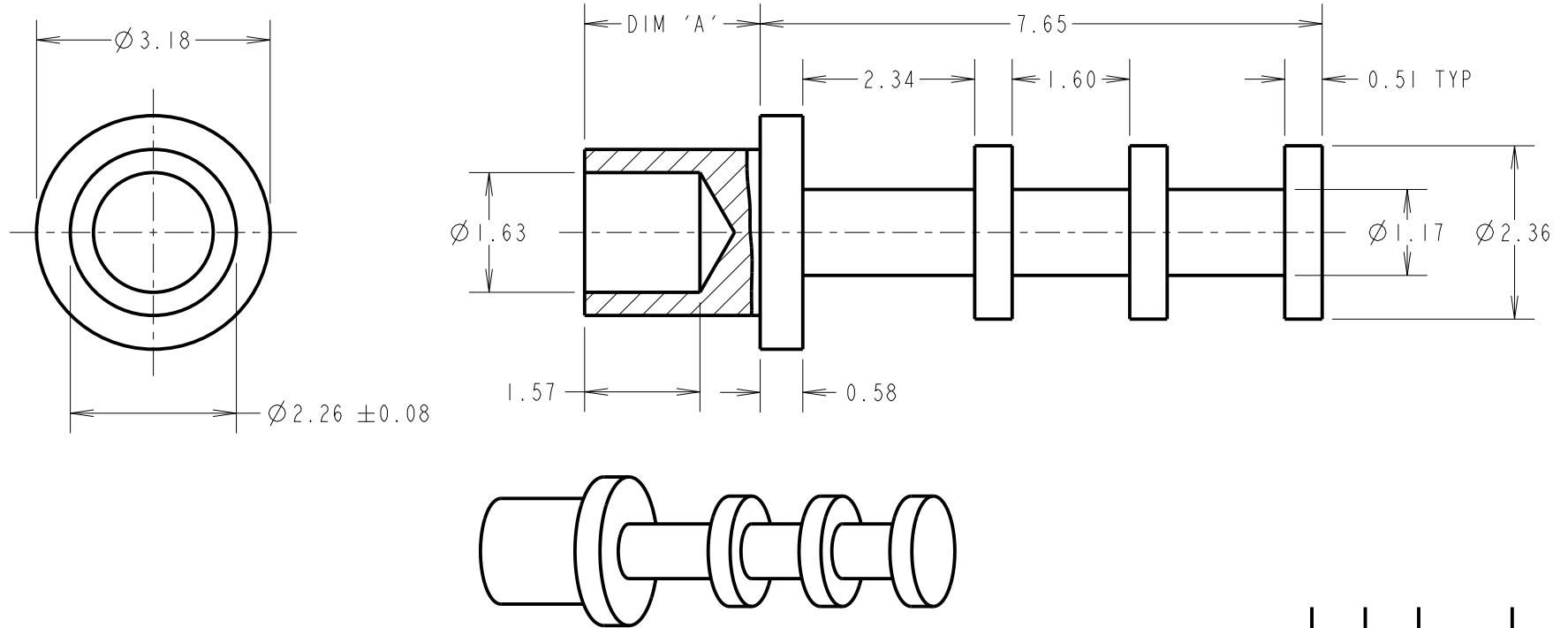

NOTES:

1. UNLESS OTHERWISE STATED, TOLERANCES = ± 0.13 .

PART No.	DIM 'A'	HOLE SIZE	BOARD THICKNESS	PUNCH AND DIE TOOL
H9020-01	2.39	$\varnothing 2.35/2.45$ mm	1.60mm	Z9020-00
H9021-01	3.18	$\varnothing 2.35/2.45$ mm	2.40mm	Z9021-00

MGP	16	09.02.22	31362
NAME	ISS.	DATE	CN/CO
APPROVED: MGP			
CHECKED: RA			
DRAWN: J. KEIR			
CUSTOMER REF.:			
ASSEMBLY DRG:			

HARWIN

www.harwin.com
technical@harwin.com

THIS DRAWING AND ANY INFORMATION OR DESCRIPTIVE MATTER SET OUT HEREON ARE CONFIDENTIAL AND COPYRIGHT PROPERTY OF THE HARWIN GROUP AND MUST NOT BE DISCLOSED, LOANED, COPIED OR USED FOR MANUFACTURING, TENDERING OR FOR ANY OTHER PURPOSE WITHOUT THEIR WRITTEN PERMISSION.

~~TOLERANCES~~
~~X = ± 1 mm~~
~~X.X = ± 0.50 mm~~
~~X.XX = ± 0.20 mm~~
~~X.XXX = ± 0.01 mm~~
 ANGLES = $\pm 5^\circ$
 UNLESS STATED

MATERIAL:
 ANNEALED BRASS
 CW614N M TO BS EN 12164
 FINISH: 100% TIN OVER NICKEL
 S/AREA: mm²

TITLE:
 TERMINAL LUG
 DRAWING NUMBER:
H9020-01 TO H9021-01

SHT
 2 OF 2