

## 2.54mm PCB connectors

Order code	Manufacturer code	Description
22-2576	n/a	REEL 1000 0.156" CRIMP TERMINAL (RC)

2.54mm PCB connectors	Page 1 of 2
The enclosed information is believed to be correct, Information may change without notice due to product improvement. Users should ensure that the product is suitable for their use. E. & O. E.	Revision A 20/02/2007

22-2576

34

**EVER-CONN  
E.C.I.**

**8578 SERIES**

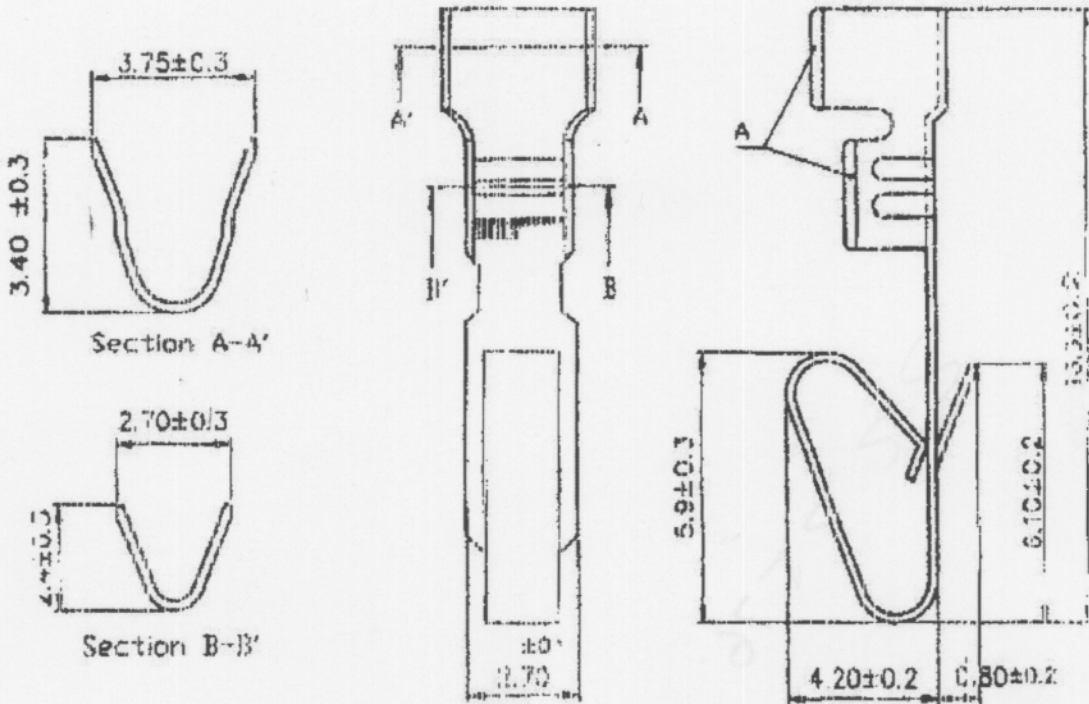

THICKNESS: 0.25mm & 0.30mm  
 MAT'L: BRASS OR PHOSPHOR BRONZE TIN PLATED  
 CURRENT RATING: 5A-7A AC,DC  
 VOLTAGE RATING: 250V AC,DC  
 APPLICABLE WIRE RANGE: AWG#16-20  
 MATES WITH: 8639, 8669, 3095-05, 5080 & 7500 SERIES HOUSING  
 ACCEPT'S WITH 1/4" (0.045") SQUARE PIN  
 UL FILE NO: E115256  
 CSA FILE NO: LR84767  
 TUV FILE NO: 93 02 14023 512



REVISIONS		REV 0							
TOLERANCES UNLESS OTHERWISE SPECIFIED	PARTIT I	±0.4	±0.5	MARK	REVISED	DATE	SCALE	BY	CHKD
	TYPE	20-40	40 UP	ISSUED	LAY	RECHK.	ANGLES	3711	ADN/12
	PARTIT II	±0.2	±0.3				DATE	DWG NO.	
		1-10	10-20				00.12.25	8578	