

RFid click™

1. Introduction

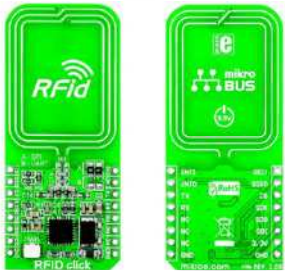

RFid click™ is an accessory board in **mikroBUS™** form factor. It's a compact and easy solution for adding RFid to your design. It features **CR95HF** 13.56 MHz contactless transceiver as well as trace antenna. RFid click™ communicates with the target board microcontroller via **mikroBUS™** UART (TX, RX), SPI (MISO, MOSI, SCK, CS) INT, RST, PWM and AN lines. The board is designed to use 3.3V power supply only. LED diode (GREEN) indicates the presence of power supply.

2. Soldering the headers

Before using your click™ board, make sure to solder 1x8 male headers to both left and right side of the board. Two 1x8 male headers are included with the board in the package.



1

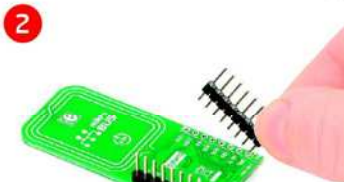

Turn the board upside down so that bottom side is facing you upwards. Place shorter pins of the header into the appropriate soldering pads.



Turn the board upward again. Make sure to align the headers so that they are perpendicular to the board, then solder the pins carefully.

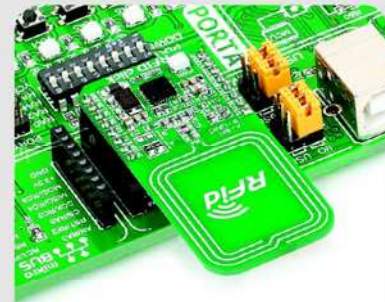

4. Essential features

RFid click™ with its **CR95HF** IC is a RFid module with integrated transceiver for contactless applications. The board contains dedicated internal frame controller and analog front end (AFE) for RF communications. It supports ISO/IEC 14443 type A and B, ISO/IEC 15693 and ISO/IEC 18092 protocols (tags) as well as the detection, reading and writing of NFC forum type 1, 2, 3 and 4 tags.

3. Plugging the board in

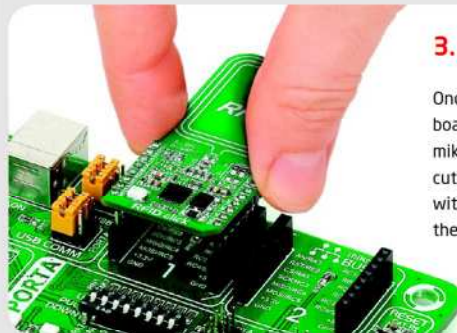

Once you have soldered the headers your board is ready to be placed into desired mikroBUS™ socket. Make sure to align the cut in the lower-right part of the board with the markings on the silkscreen at the mikroBUS™ socket. If all of the pins are aligned correctly, push the board all the way into the socket.

click™
BOARD
www.mikroe.com

RFid click Manual
ver. 1.00



0 100000 024140



5. Rfid click™ Board Schematic

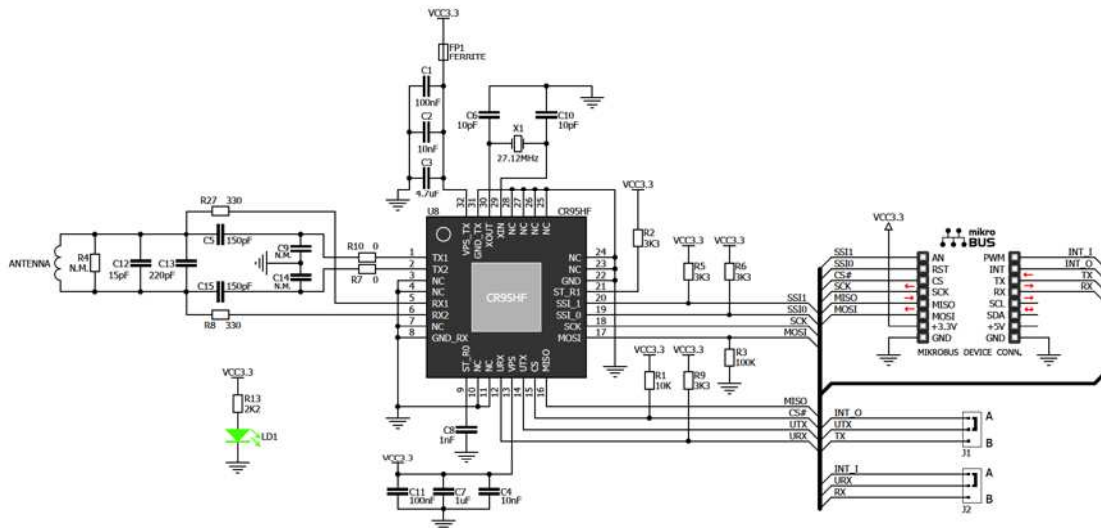

6. SMD jumpers



Two SMD jumpers are provided on the board. In case you want to use UART interface, it is necessary to solder SMD jumpers in **B** position. Otherwise if you want to use SPI interface, jumpers should be left in its default position (**A**). In that case interrupt pins (IN and OUT) are usable.

7. Code Examples

Once you have done all the necessary preparations, it's time to get your click™ board up and running. We have provided the examples for mikroC™, mikroBasic™ and mikroPascal™ compilers on our **Libstock** website. Just download them and you are ready to start.



8. Support

MikroElektronika offers **Free Tech Support** (www.mikroe.com/esupport) until the end of product lifetime, so if something goes wrong, we are ready and willing to help!

