

# KA/802000/M

## Stainless Steel ISOLine™ 15552 cylinder, double acting



- > ø 32 ... 200 mm
- > High performance adaptive cushioning system "ACS"
- > High temperature version up to +150 °C
- > High corrosion and acid resistance
- > Ideal for applications in the food industry



### Technical features

#### Medium:

Compressed air, filtered, lubricated or non-lubricated

#### Standard:

ISO 15552

#### Operation:

Double acting, adjustable cushioning

#### Operating pressure:

ø 32 ... 200 mm

Cylinder with Round barrel

1 ... 16 bar (14 ... 232 psi)

#### Ports:

G1/8 ... 3/4

#### Cylinder diameters:

32, 40, 50, 63, 80, 100, 125, 160, 200 mm

#### Standard strokes:

25, 50, 80, 100, 125, 160, 200, 250, 320, 400, 500 mm

#### Non-standard strokes:

Available (5 ... 2500 mm)

#### Operating temperature:

ø 32 ... 200 mm

"Standard version"

-10 ... +80 °C max. (+14 ... +176 °F)

ø 32 ... 200 mm

"High temperature version" (T)

0 ... +150 °C max.

(-17,7 ... +302 °F)

Air supply must be dry enough to avoid ice formation at temperatures below +2 °C (+35 °F).

#### Standard Materials:

Barrel: X5 Cr Ni 18 10

(1.4301; AISI 304)

End covers: X5 Cr Ni 19 10

(1.4308; AISI 304)

Piston rod: X10 Cr Ni S 18 9

(1.4305; AISI 303)

Nuts and screws: X10 Cr Ni S

18 9

(1.4305; AISI 303)

Tie rods: X5 Cr Ni Mo 17 12 2

(1.4401; AISI 316)

Piston rod seals: FPM

Piston seals:

PUR ø 32 ... 100 mm,

NBR ø 125 ... 200 mm

Cushion seals: NBR

O-rings: FPM

### Technical data

Cylinder ø (mm)	32	40	50	63	80	100	125	160	200
Port size	G1/8	G1/4	G1/4	G3/8	G3/8	G1/2	G1/2	G3/4	G3/4
Piston rod ø (mm)	12	16	20	20	25	25	32	40	40
Piston rod thread	M10x1,25	M12x1,25	M16x1,5	M16x1,5	M20x1,5	M20x1,5	M27x2	M36x2	M36x2
Cushion length (mm)	20	22	24	24	26	33	39	43	43
Cushioning									
Adaptive cushioning systems "ACS"	•	•	•	•	•	•	•		
Cushioning (adjustable cushion)								•	•
Initial cushion volume (cm <sup>3</sup> )	12,8	20,2	36	64	111	235	427	784	1273
Theoretical thrusts at 6 bar outstroke (N)	482	754	1178	1870	3016	4710	7363	12064	18840
Theoretical thrusts at 6 bar instroke (N)	414	633	990	1680	2722	4416	6882	11310	18090
Air consumption at 6 bar outstroke (l/cm)	0,056	0,088	0,137	0,218	0,35	0,55	0,86	1,41	2,2
Air consumption at 6 bar instroke (l/cm)	0,048	0,074	0,114	0,195	0,32	0,51	0,79	1,32	2,1

### The function

The new "ACS" Adaptive Cushioning System provides a high performance pneumatic damping function. The system will automatically cushion for a wide range of general applications as delivered. Manual adjustment is still possible for extreme applications.

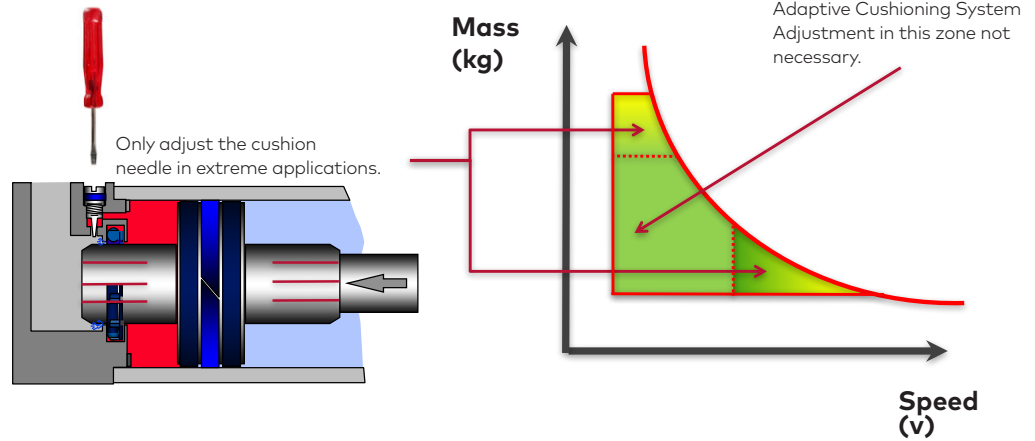

### Design and sizing in pneumatics

#### Golden Rules

Design and sizing in pneumatics is often based upon experience coupled with an element of fear of under specifying crucial equipment. In an attempt to ensure enough power, engineers may select over sized cylinders and then select over sized valves to supply them with enough air. The same uncertainty can also lead to over sized specification of air line equipment, fittings and tubing. The outcome is components larger than necessary that use too much compressed air and waste energy and money. However when following some well proven golden rules and a few laws of pneumatics it is easy to achieve correctly sized pneumatic installations.

#### Basics to Consider

The force required, the pressure available, the speed of movement and air consumption. ISO and VDMA standard or compact style also cushioning and sensors. Cylinders are greased on assembly and operate under normal conditions without additional lubrication. However using a lubricator will extend the life of these products.

#### Golden Rule:

The theoretical force of the cylinder should be 25% extra for high speed, 50% extra for low speed and 100% extra for ultra low speed (positioning) applications. The correct sizing is based upon the required force and applied pressure. Go to page 1 for more information on cylinder sizing and air consumption.





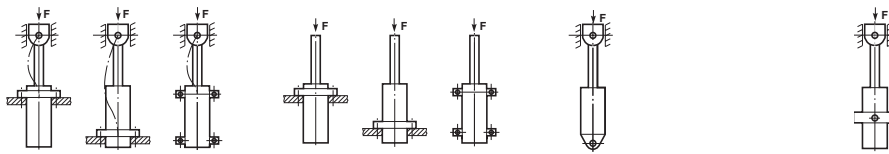

















### Load and Buckling

For applications with high side loading, use pneumatic slide actuators or standard cylinders fitted with guide units. Alternatively external guide bearings should be installed. When a long stroke length is specified, care must be taken to ensure the rod length is within the limits for prevention of buckling. The table shows the maximum stroke length for a variety of installation arrangements.



Cylinder ø (mm)	Piston rod ø (mm)	Load case 1 Pressure (bar)				Load case 2 Pressure (bar)				Load case 3 Pressure (bar)				Load case 4 Pressure (bar)			
		4	6	10	16	4	6	10	16	4	6	10	16	4	6	10	16
32	12	1100	860	650	500	500	390	290	210	650	520	380	290	760	600	450	340
40	16	1600	1200	950	730	730	580	430	320	940	750	560	430	1100	880	660	500
50	20	2000	1600	1200	930	930	740	550	420	1200	960	720	550	1400	1100	840	640
63	20	1500	1200	930	720	720	570	420	310	930	740	550	420	1100	860	650	490
80	25	1900	1500	1100	880	880	700	510	380	1100	910	680	510	1300	1100	800	600
100	25	1500	1200	880	670	670	520	380	270	880	690	510	370	1000	820	600	450
125	32	2000	1600	1200	910	910	710	520	380	1200	940	690	520	1400	1100	820	620
160	40	2400	1900	1500	1100	1100	880	640	480	1400	1200	860	640	1700	1400	1000	760
200	40	1900	1500	1100	860	860	670	480	350	1100	890	650	480	1300	1000	770	580

**Additional ISO 15552 Cylinder ranges (Cylinder ranges in the red frame are shown in this data sheet.)**

													
Symbols		Profile barrel	Round Barrel	Industrial Automation	Food & Beverage	Automotive	ATEX II 2GD	Rail *)	CE-marked	ø (mm)	Range	Description	Datasheet
		•	•	•	•	•	•	•	•	32 ... 125	PRA/802000 LPRA/802000	Double Acting Cylinder	1_5_220_PRA_802000_M_RA_8000_M 1_5_225_PRA_802000_M_EX 1_5_220_LPRA_802000_M_LRA_8000_M
		•	•	•	•	•	•	•	•	32 ... 125	RA/802000 LPRA/802000	Double Acting Cylinder	1_5_220_PRA_802000_M_RA_8000_M 1_5_225_PRA_802000_M_EX 1_5_220_LPRA_802000_M_LRA_8000_M
		•	•	•	•	•	•	•	•	160 ... 320	RA/8000 LRA/8000	Double Acting Cylinder	1_5_220_PRA_802000_M_RA_8000_M 1_5_126_RA_8000_M_EX 1_5_220_LPRA_802000_M_LRA_8000_M
		•	•	•	•	•	•	•	•	32 ... 200	KA/802000	Stainless steel Cylinder	1_5_222_KA_802000_M 1_5_228_KA_802000_M_EX
		•	•	•	•	•	•	•	•	32 ... 100	PRA/822000	Smooth Line Cylinder	1_5_230_PRA_822000_M 1_5_235_PRA_822000_M_EX
		•	•	•	•	•	•	•	•	32 ... 100	PRA/842000	Clean Line Cylinder	1_5_240_PRA_842000_M 1_5_245_PRA_842000_M_EX
		•	•	•	•	•	•	•	•	32 ... 100	PRA/862000	IVAC Industrial Cylinder	1_5_250_PRA_862000_M 1_5_255_PRA_862000_M_EX
		•	•	•	•	•	•	•	•	32 ... 100	PRA/882000	IVAC Clean Line Cylinder	1_5_260_PRA_882000_M 1_5_265_PRA_882000_M_EX
		•	•	•	•	•	•	•	•	40 ... 125	PSA/182000/ F1	Cylinder with position sensor	1_9_051_PSA_182000_F1 1_9_052_PSA_182000_F1_EX
		•	•	•	•	•	•	•	•	160 ... 320	SA/8000/F1	Cylinder with position sensor	Datasheet (standard) 1_9_062_SA_8000_F1_EX
		•	•	•	•	•	•	•	•	32 ... 100	PRA/801000, PRA/803000	Standard Single Acting Cylinder	1_4_101_PRA_801000_803000 -
		•	•	•	•	•	•	•	•	32 ... 100	RA/801000, RA/803000	Standard Single Acting Cylinder	1_4_101_PRA_801000_803000 -

• Range available. For additional information please contact the technical service or <http://www.imi-precision.com>

\*1) Rail Cylinder Shock and vibration tested to EN 61373 Category 1; Class A + B

## Cylinder variants

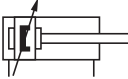
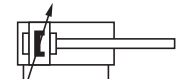
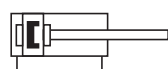
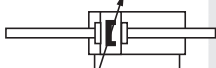
Symbol Please see the description below	Versions		Piston Rod Material		Standard Model with		ø (mm)	Description	Page			
	H	L	T	R	S	C				D	Male Piston Rod Thread	Female Piston Rod Thread
			•		X			.KA/802000/M	.KA/802000/MX	32 ... 125	Standard Cylinder	8/9
			•		X			.KA/802000/M	-	160 ... 200	Standard Cylinder	8
					X			.KA/802000/W2	.KA/802000/W2X	32 ... 125	Cylinder with Special Wiper - Seal (suitable for appl. with cement, plaster (stucco), arizona sand, hoar-frost or ice)	8/9
					X			.KA/802000/W2	-	160 ... 200		
			•		X			.KA/802000/MU	.KA/802000/MUX	32 ... 125	Cylinder with Extended Piston Rod Maximum stroke: 2000 Maximum extension: 800	8/9
			•		X			.KA/802000/MU	-	160 ... 200		
					X			.KA/802000/W6	.KA/802000/W6X	32 ... 125	Cylinder with Extended Piston Rod and Special Wiper - Seal Maximum stroke: 2000 suitable for appl. with cement, plaster (stucco), arizona sand, hoar-frost or ice	8/9
					X			.KA/802000/W6	-	160 ... 200		
			•		X			.KA/802000/MW	.KA/802000/MWX	32 ... 125	Cylinder without Cushioning	8/9
			•		X			.KA/802000/MW	-	160 ... 200		
			•		X			.KA/802000/JM	.KA/802000/JMX	32 ... 125	Cylinder with Double Ended Piston Rod	9
			•		X			.KA/802000/JM	-	160 ... 200		
					X			.KA/802000/W4	.KA/802000/W4X	32 ... 125	Cylinder with Double Ended Piston Rod and Special Wiper - Seal without Magnet (suitable for appl. with cement, plaster (stucco), arizona sand, hoar-frost or ice)	8/9
					X			.KA/802000/W3	-	160 ... 200		

Note: Versions: H = Hydraulic (ø 32 ... 100 mm); L = Low temperature -40 °C (-40 °F) (ø 32 - 125mm), -30 °C (-22 °F) (ø 160 -200 mm); T = High temperature +150 °C (+302 °F); Piston Rod Material: C = Hard chromium plated; D = Stainless steel austenitic & hard chromium plated; K, S = Stainless steel austenitic; X = Standard; • = Option

**Option selector**

\*KA/802\*\*\*/\*\*\*/\*\*\*

Non-standard variants	Substitute
High temperature version +150 °C max. (+302 °F)	<b>T</b>
Cylinder ø (mm)	Substitute
032, 040, 050, 063, 080, 100, 125, 160, 200	
Variants ø 32 ... 200 mm (magnetic piston)	Substitute
Standard	<b>M</b>
Special wiper/seal	<b>W2</b>
Without cushion	<b>MW</b>
Double ended piston rod	<b>JM</b>
Double ended piston rod, special wiper/seal	<b>W4</b>
Extended piston rod	<b>MU</b>
KA/8****/MU/****/***	<b>Extension (mm)</b>
Extended piston rod, special wiper/seal	<b>W6</b>
KA/8****/W6/****/***	<b>Extension (mm)</b>







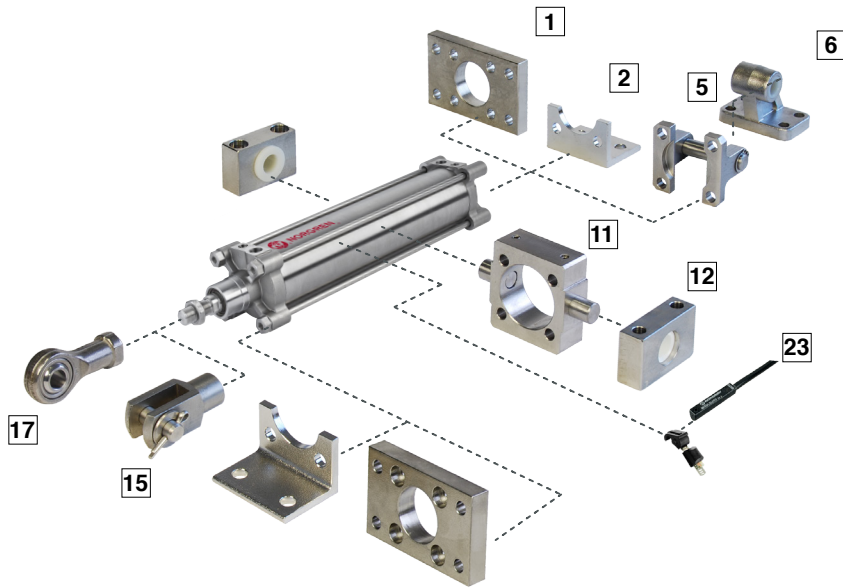

Strokes (mm)	Substitute
5 ... 2500	
Piston rod thread	Substitute
Male	<b>None</b>
Female (Ø32 ... 125 mm)	<b>X</b>

Note: If position is not required, disregard option position within part number e.g. KA/802100/M/100. For combinations of cylinder variants consult our technical service.

Additional variants/options are not possible.

Detail's see table on page 4.

**Cylinder with Round barrel  $\varnothing$  32 ... 200 mm**

**Mountings**

	B, G	C	D	F	S	SW	UF	UH
								
<b>Cyl. <math>\varnothing</math></b>	<b>1</b> Page 10	<b>2</b> Page 10	<b>5</b> Page 10	<b>15</b> Page 10	<b>12</b> Page 11	<b>6</b> Page 11	<b>17</b> Page 11	<b>11</b> Page 11
32	KQA/8032/22	KQA/8032/21	KQA/8032/23	KQM/55433/25	KQA/8032/41	M/P72288	KQM/8032/32	KQA/8032/40
40	KQA/8040/22	KQA/8040/21	KQA/8040/23	KQM/55441/25	KQA/8040/41	M/P72289	KQM/8040/32	KQA/8040/40
50	KQA/8050/22	KQA/8050/21	KQA/8050/23	KQM/55451/25	KQA/8040/41	M/P72290	KQM/8050/32	KQA/8050/40
63	KQA/8063/22	KQA/8063/21	KQA/8063/23	KQM/55451/25	KQA/8063/41	M/P72291	KQM/8050/32	KQA/8063/40
80	KQA/8080/22	KQA/8080/21	KQA/8080/23	KQA/8080/25	KQA/8063/41	M/P72292	KQM/8080/32	KQA/8080/40
100	KQA/8100/22	KQA/8100/21	KQA/8100/23	KQA/8080/25	KQA/8100/41	M/P72293	KQM/8080/32	KQA/8100/40
125	KQA/8125/22	KQA/8125/21	KQA/8125/23	KQA/8125/25	KQA/8100/41	-	KQM/8125/32	KQA/8125/40
160	-	-	-	-	-	-	-	-
200	-	-	-	-	-	-	-	-
<b>Position</b>	<b>Style</b>	<b>Stainless steel</b>			<b>Position</b>	<b>Style</b>	<b>Standard</b>	
<b>1</b>	B, G	X 5 Cr Ni 18 10 (1.4301; AISI 304). Screws: A2			<b>12</b>	S	Swivel bearing: X 10 Cr Ni S 18 9 (1.4305; AISI 304), bearing: PA	
<b>2</b>	C	X 5 Cr Ni 18 10 (1.4301; AISI 304). Screws: A2			<b>15</b>	F	Clevis mounting: X 10 Cr Ni S 18 9 (1.4305; AISI 303), Bolt: X 10 Cr Ni S 18 9 (1.4305; AISI 303), Circlip: X 10 Cr Ni S 18 9 (1.4305; AISI 303)	
<b>5</b>	D	X 5 Cr Ni 18 10 (1.4301; AISI 304). Screws: A2 Bolt: X 10 Cr Ni S 18 9 (1.4305; AISI 303)			<b>17</b>	UF	X 10 Cr Ni S 18 9 (1.4305; AISI 303), Inner ring X 105 Cr Co Mo 18-2 (1.4528), Outer ring X 5 Cr Ni 18 10 (1.4301; AISI 304)	
<b>6</b>	SW	X 6 Cr Ni 18 9 (1.4308; AISI 304)				Bracket for switches	Body: PA/PP, screw and holding strap A2	
<b>11</b>	UH	Adjustable intermediate mounting: X 10 Cr Ni S 18 9 (1.4305; AISI 303), Bolts: X 10 Cr Ni S 18 9 (1.4305; AISI 303), screws: A2						

### Accessories Round barrel (ø 32 ... 200 mm)

Model	ø	Port size	Straight fitting	Elbow fitting
KA/802032/M/*	32	G1/8	S02250618	C02470618
KA/802040/M/*	40	G1/4	S02250628	C02470628
KA/802050/M/*	50	G1/4	S02250828	C02470828
KA/802063/M/*	63	G3/8	S02250838	C02470838
KA/802080/M/*	80	G3/8	S02251038	C02471038
KA/802100/M/*	100	G1/2	S02251248	C02471248
KA/802125/M/*	125	G1/2	S02251248	C02471248
KA/802160/M/*	160	G3/4	-	-
KA/802200/M/*	200	G3/4	-	-



For alternative fitting types please contact the technical service.

### Service kit

Service kit for Round and Profile barrel*	
ø	Part number
32	KQA/8032/00
40	KQA/8040/00
50	KQA/8050/00
63	KQA/8063/00
80	KQA/8080/00
100	KQA/8100/00
125	KQA/8125/00
160	KQA/8160/00
200	KQA/8200/00

\*For TKA high temperature cylinders, replace 'KQA' with 'TQA' for the high temperature spares kit

### Magnetically operated switches

ø	M/50/**	Switch mounting brackets for M/50
		
		<b>23</b>
ø	Page 12-15	Page 15
32		QM/27/2/1
40		QM/27/2/1
50		QM/27/2/1
63		QM/27/2/1
80		QM/27/2/1
100		QM/27/2/1
125		QM/27/2/1
160		QM/27/2/1
200		QM/27/2/1

**Basic dimensions**  
**KA/802000/M**  
**Standard Cylinder**  
**ø 32 - 200 mm**

Dimensions in mm  
 Projection/First angle

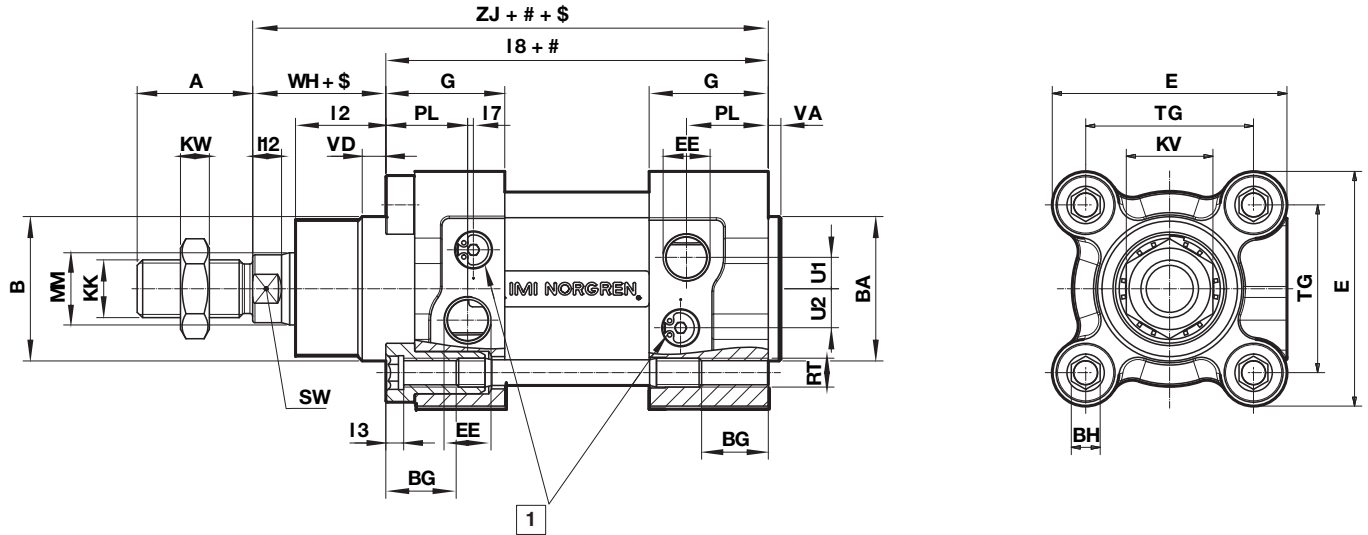

# Stroke

\$ Piston rod extension

1 Cushion screw

For additional information please contact the technical service or  
<http://www.imi-precision.com>

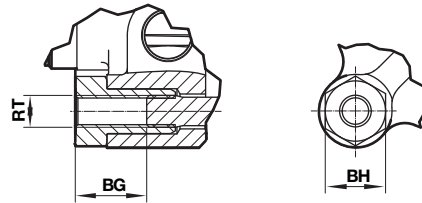

ø	A-0,5	ø B d11	ø BA d11	BG min	BH	E	EE	G	KK	KV	KW	L2	L3	L7	L8	L12	ø MM h9	PL	TG
32	22	30	30	16	6	47	G1/8	29	M10x1,25	17	5	19,5	4	6,6	94	5,5	12	15	32,5
40	24	35	35	16	6	53	G1/4	34,5	M12x1,25	19	6	22	4	5,6	105	6,5	16	21,5	38
50	32	40	40	16	8	65	G1/4	33	M16x1,5	24	8	25	5	1,6	106	8	20	22,7	46,5
63	32	45	45	16	8	75	G3/8	36,5	M16x1,5	24	8	25	5	3,6	121	8	20	24,2	56,5
80	40	45	45	17	19	95	G3/8	42	M20x1,5	30	10	33	-	1,8	128	10	25	29,7	72
100	40	55	55	17	19	113	G1/2	42	M20x1,5	30	10	35	-	3,8	138	10	25	27,7	89
125	54	60	60	20	24	140	G1/2	54	M27x2	41	13,5	44	-	1,8	160	13	32	39,7	110
160	72	65	65	28,5	32	180	G3/4	55	M36x2	55	18	58	-	-	180	16	40	31,5	140
200	72	75	75	28,5	32	220	G3/4	52,5	M36x2	55	18	67	-	-	180	16	40	26,5	175

ø	RT	SW	U1	U2	VA	VD	WH	ZJ	Model Round barrel	at 0 mm	per 25 mm
32	M6	10	4,6	6,3	3,5	6	26	120	KA/802032/M/*	0,9 (kg)	0,06 (kg)
40	M6	13	5,8	9,2	3,5	6	30	135	KA/802040/M/*	1,3 (kg)	0,08 (kg)
50	M8	17	8,7	10,8	3,5	6	37	143	KA/802050/M/*	2,0 (kg)	0,13 (kg)
63	M8	17	10	12,8	3,5	6	37	158	KA/802063/M/*	3,0 (kg)	0,14 (kg)
80	M10	22	12	14,5	3,5	6	46	174	KA/802080/M/*	5,0 (kg)	0,30 (kg)
100	M10	22	9	14,5	3,5	6	51	189	KA/802100/M/*	7,3 (kg)	0,34 (kg)
125	M12	27	12	17	5,5	8	65	225	KA/802125/M/*	12,2 (kg)	0,51 (kg)
160	M16	36	15	17	6	10	80	260	KA/802160/M/*	23,4 (kg)	0,88 (kg)
200	M16	36	19	14	6	10	95	275	KA/802200/M/*	34,4 (kg)	1,14 (kg)

\* Please insert stroke length.

Basic Dimension are also for cylinder variants or for different piston rod material

TKA/802000/M - High Temperature Cylinder

KA/802000/W2 - Cylinder with Special Wiper - Seal

KA/802000/MU - Cylinder with Extended Piston Rod

KA/802000/W6 - Cylinder with Extended Piston Rod and Special Wiper - Seal

KA/802000/MW - Cylinder without Cushioning



**Cylinder variants**  
**KA/802000/MX; /MUX; /MWX; /W2X; /W6X**  
**Cylinder with Female Piston Rod Thread**

Dimensions in mm  
 Projection/First angle

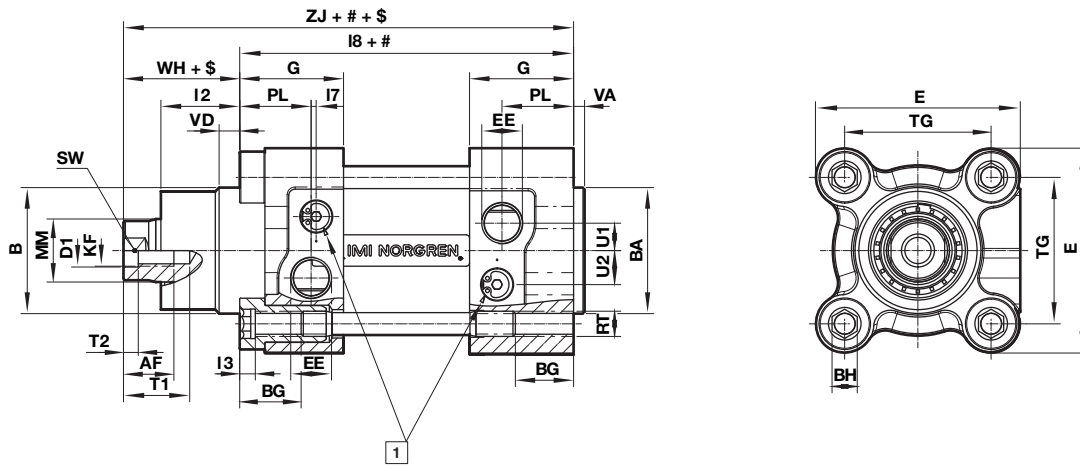

# Stroke

ø	AF	ø D1	KF	I12	ø MM h9	SW	T1	T2
32	12	6,4	M6	5,5	12	10	16	2,6
40	12	8,4	M8	6,5	16	13	16	3,3
50	16	10,5	M10	8	20	17	21	4,7
63	16	10,5	M10	8	20	17	21	4,7
80	20	13	M12	10	25	22	25	6,1
100	20	13	M12	10	25	22	25	6,1
125	32	17	M16	13	32	27	38	8

For missing dimensions please see page 8.

**KA/802000/JM, KA/802000/W4 – Cylinder with Double Ended Piston Rod**  
**KA/802000/JMX, KA/802000/W4X – Cylinder with Double Ended Piston Rod**  
**and Female Piston Rod Thread**

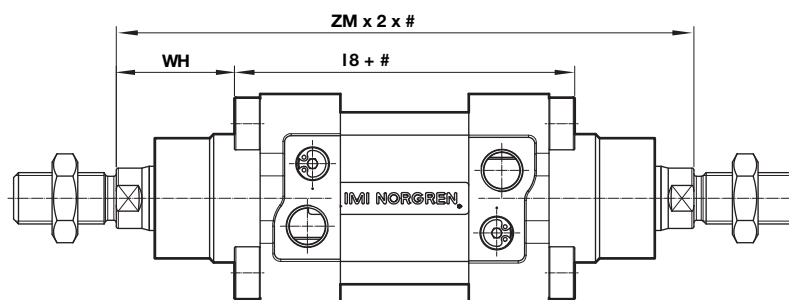

# Stroke

ø	L8	WH	ZM	Model Round barrel
32	94	26	146	KA/802032/JM/*
40	105	30	165	KA/802040/JM/*
50	106	37	180	KA/802050/JM/*
63	121	37	195	KA/802063/JM/*
80	128	46	220	KA/802080/JM/*
100	138	51	240	KA/802100/JM/*
125	160	65	290	KA/802125/JM/*
160	180	80	340	KA/802160/JM/*
200	180	95	370	KA/802200/JM/*

\* Please insert stroke length; For missing dimensions please see page 8.

### Mountings

#### Front flange B, G

Conforms to ISO 15552, type MF1 and MF2

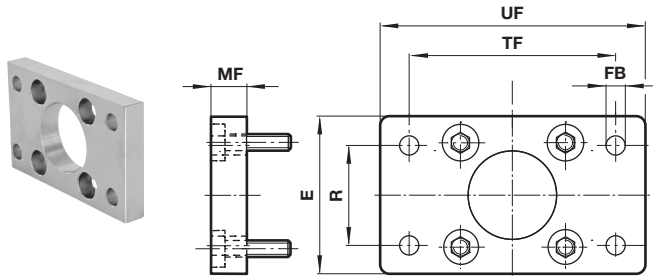

Ø	E	Ø FB	MF	R	TF	UF	kg	Model (B, G)
32	50	7	10	32	64	80	0,26	KQA/8032/22
40	55	9	10	36	72	90	0,31	KQA/8040/22
50	65	9	12	45	90	110	0,56	KQA/8050/22
63	75	9	12	50	100	125	0,73	KQA/8063/22
80	100	12	16	63	126	154	1,73	KQA/8080/22
100	120	14	16	75	150	186	2,51	KQA/8100/22

#### Foot mounting C

Conforms to ISO 15552, type MS1

Dimensions in mm  
Projection/First angle

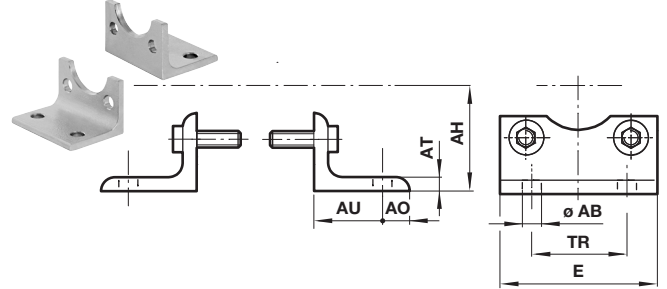

Ø	Ø AB	AH	AO	AT	AU	E	TR	kg	Model (C)
32	7	32	11	4	24	48	32	0,16	KQA/8032/21
40	9	36	12	5	28	53	36	0,19	KQA/8040/21
50	9	45	13	5	32	64	45	0,32	KQA/8050/21
63	9	50	13	5	32	74	50	0,41	KQA/8063/21
80	12	63	19	6	41	98	63	0,83	KQA/8080/21
100	14	71	19	6	41	115	75	0,98	KQA/8100/21

#### Rear clevis D

Conforms to ISO 15552, type MP2

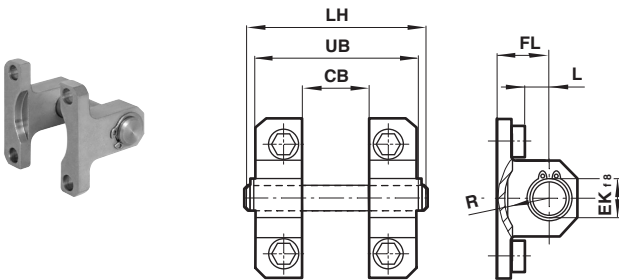

Ø	CB H14	Ø EK f8	FL	L	LH	R	UB	kg	Model (D)
32	26	10	22	13	52	9	45	0,11	KQA/8032/23
40	28	12	25	16	60	12	52	0,16	KQA/8040/23
50	32	12	27	17	68	12	60	0,22	KQA/8050/23
63	40	16	32	22	79	15	70	0,34	KQA/8063/23
80	50	16	36	22	99	15	90	0,54	KQA/8080/23
100	60	20	41	27	119	20	110	0,9	KQA/8100/23

#### Piston rod clevis F

Conforms to DIN ISO 8140

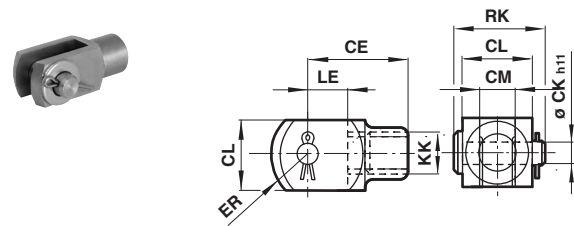

Ø	KK	CE	ØCKh11	CL	CM	ER	LE	RK	kg	Model (F)
32	M10x1,25	40	10	20	10	16	20	28	0,09	KQM/55433/25
40	M12x1,25	48	12	24	12	19	24	32	0,13	KQM/55441/25
50/63	M16x1,5	64	16	32	16	25	32	41,5	0,33	KQM/55451/25
80/100	M20x1,5	80	20	40	20	32	40	50	0,67	KQM/8080/25

### Trunnion support S

Conforms to ISO 15552, type AT4

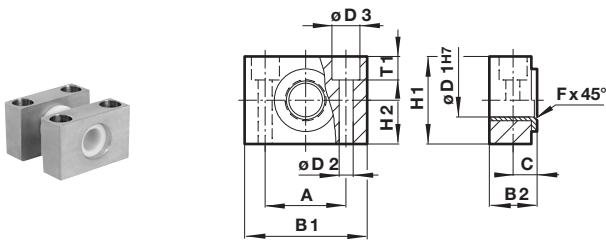

### Wide hinge SW

Conforms to ISO 15552, type AB7

Dimensions in mm  
Projection/First angle

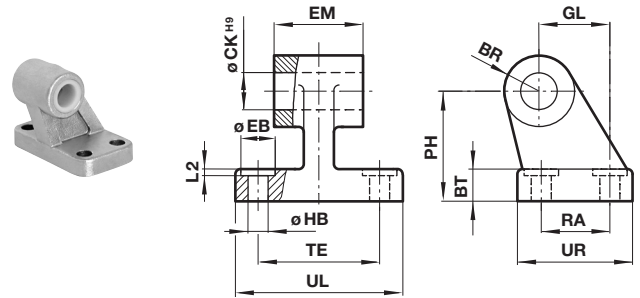

Ø	A	B	C	ØD	Fx	H	T1	kg	Model (S)				
	1	2		1	45°	1	2						
32	32	46	18	10,5	12	6,6	11	1	30	15	6,8	0,1	KQA/8032/41
40/50	36	55	21	12	16	9	15	1,6	36	18	9	0,14	KQA/8040/41
63/80	42	65	23	13	20	11	18	1,6	40	20	11	0,18	KQA/8063/41
100/125	50	75	28,5	16	25	14	20	2	50	25	13	0,34	KQA/8100/41

Ø	CA	ØCK	ØEM	G	H2	K	L1	R	ØS	kg	Model (SW)				
		H9	D	1	2	1	2								
32	32	10	11	26	21	18	31	8	38	51	1,6	10	6,6	0,15	M/P72288
40	36	12	11	28	24	22	35	10	41	53	1,6	11	6,6	0,21	M/P72289
50	45	12	15	32	33	30	45	12	50	65	1,6	13	9	0,41	M/P72290
63	50	16	15	40	37	35	50	12	52	67	1,6	15	9	0,53	M/P72291
80	63	16	18	50	47	40	60	14	66	86	2,5	15	11	0,82	M/P72292
100	71	20	18	60	55	50	70	15	76	96	2,5	19	11	1,22	M/P72293

### Universal piston rod eye UF

Conforms to DIN ISO 8139

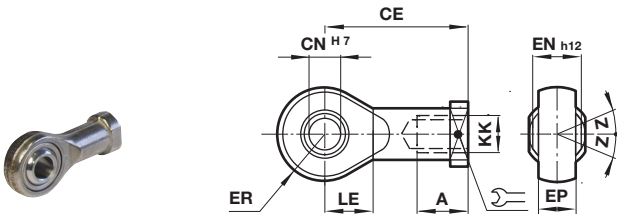

### Adjustable trunnion mounting UH

Conforms to ISO 15552, type MT4

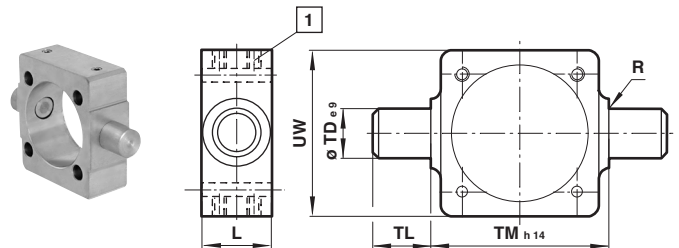

1 Locking screws

Torque max: Ø 32 & 40 mm = 6 Nm; Ø 50 & 63 mm = 10 Nm;  
Ø 80 & 100 mm = 15 Nm; Ø 125 mm = 25 Nm

Ø	Thread KK	AX	CE	Ø CNH7	EN -0,1	ER	LE	Z	kg	Model (UF)
32	M10x1,25	20	43	10	14	14,5	14	13°	0,07	KQM/8032/32
40	M12x1,25	22	50	12	16	16,5	16	13°	0,11	KQM/8040/32
50/63	M16x1,5	28	64	16	21	21,5	21	15°	0,21	KQM/8050/32
80/100	M20x1,5	33	77	20	25	25,5	25	15°	0,38	KQM/8080/32

Ø	L	R	ØTD e9	TL	TM h14	UW	XV min.	XV max.	kg	Model (UH)
32	20	1	12	12	50	53	67,5	78,5	0,24	KQA/8032/40
40	24	1,6	16	16	63	65	78,5	86,5	0,48	KQA/8040/40
50	28	1,6	16	16	75	75	84	96	0,7	KQA/8050/40
63	28	1,6	20	20	90	95	91,5	103,5	1,35	KQA/8063/40
80	28	1,6	20	20	110	115	106	114	1,46	KQA/8080/40
100	38	2	25	25	132	140	117	123	2,76	KQA/8100/40
125	50	2	25	25	160	143	144	146	3,28	KQA/8125/40

Style 'UH': It is most important that the locking screws which secure the mounting

to the tie rod are tightened to the torque figures shown in the table below. For maximum energy input, consult our Technical Service.

Unless otherwise specified, units will be supplied with dimension 'XV' plus half the stroke length. 'XV' = Distance from the piston rod shoulder to the centre of the mounting.

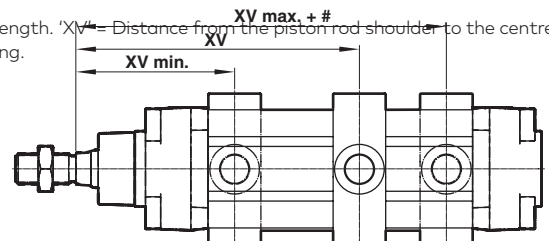

- > Magnetically operated reed switch - Round style
- > Suitable for all cylinder ranges with magnetic piston
- > LED indicator on LSU models
- > Alternative variants allows a wide range of application



### Technical features

#### Operation:

M/50/LSU Normally open with LED (yellow)

#### Switching voltage (Ub):

10 ... 240 V a.c./170 V d.c.

#### Switching voltage output:

Ub - 2,7 V

#### Switching current

(see graph overleaf):  
0,18 A max.

#### Switching power:

10 W/10 VA max.

#### Contact resistance:

150 mΩ

#### Response time:

1,8 ms

#### Operating temperature:

-25 ... +80 °C (-13 ... +176 °F)

#### High temperature version:

+150 °C max.(+302 °F)

#### Protection rating (EN 60529):

IP66

#### Shock resistance:

50 g (during 11 ms)

#### Vibration resistance:

35 g (at 2000 Hz)

#### Cable type:

2 x 0,25: PVC, PUR or silicone

3 x 0,25 PVC

#### Cable length:

2, 5 or 10 m

#### Electromagnetic compatibility

according to:  
EN 60947-5-2

#### Materials:

Body: plastic

Cable: see table below

### Technical data - Reed switches - additional information see data sheet en 4.3.005

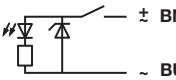
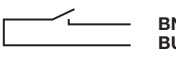
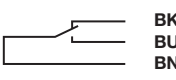
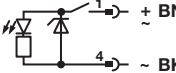
Symbol	Voltage		Current maximum (mA)	Function	Operating temperature (°C)	LED	Protection class	Plug	Cable length (m)	Cable type	Weight (g)	Model
	(V a.c.)	(V d.c.)										
	10 ... 240	10 ... 170	180	Normally open	-25 ... +80	•	IP 66	—	2,5 or 10	PVC 2x0,25	37	M/50/LSU/~V
	10 ... 240	10 ... 170	180	Normally open	-25 ... +80	•	IP 66	—	5	PUR 2x0,25	37	M/50/LSU/SU
	10 ... 240	10 ... 170	180	Normally open	-25 ... +150	—	IP 66	—	2	Silicon 2x0,25	37	TM/50/RAU/2S
	10 ... 240	10 ... 170	180	Changeover	-25 ... +80	—	IP 66	—	5	PVC 3x0,25	37	M/50/RAC/5V
	10 ... 60	10 ... 60	180	Normally open	-25 ... +80	•	IP 66	M8 x1	0,3	PVC 3x0,25	16	M/50/LSU/CP *1)
	10 ... 60	10 ... 60	180	Normally open	-25 ... +80	•	IP 66	M12 x1	0,3	PVC 3x0,25	16	M/50/LSU/CC *1)

\* Insert cable length; \*1) Plug-in connector see page 12

### Dimensions

M/50/LSU/\*V, M/50/LSU/5U,  
TM/50/RAU/2S  
Cable length L = 2, 5 or 10 m

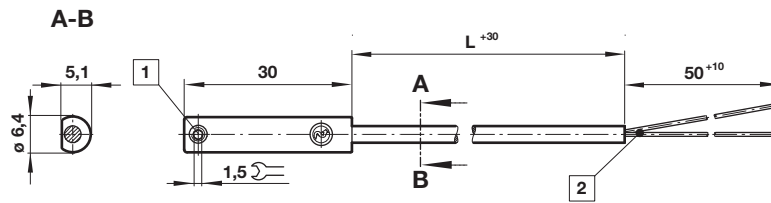

M/50/RAC/5V  
Cable length L = 5 m

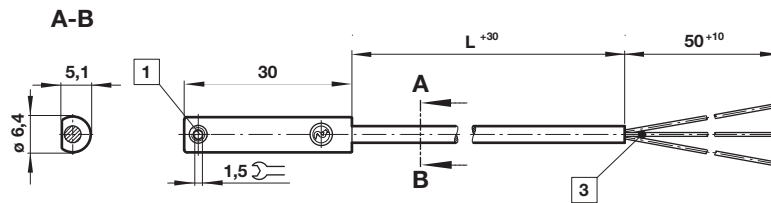

M/50/LSU/CP  
M/50/LSU/CC

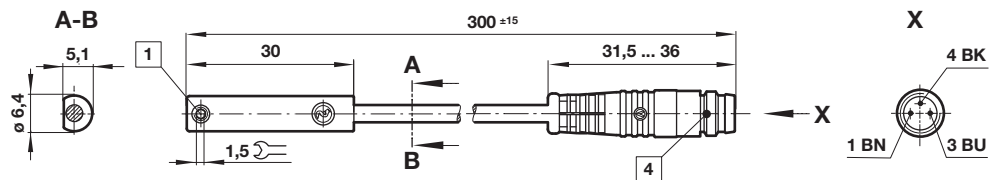

- 1 Fixing screw
- 2 + BN = brown; - BU = blue (output)
- 3 - BK = black; + BN = brown; - BU = blue
- 4 Version CP: Plug M8 x 1, color code: BK = +; BN = -; BU = output  
Version CC: Plug M12 x 1, color code: BK = +; BN = -; BU = output

### Accessories

#### Plug-in connector cable with nut



Outer cover	Cable length (m)	Weight (kg)	Connector	Connector
PVC 3x0,25	5	0,18	M8x1	M/P73001/5*1)
PUR 3x0,25	5	0,18	M8x1	M/P73002/5*1)
PVC 3x0,25	5	0,18	M8x1	M/P34615/5*2)
PUR 3x0,25	5	0,18	M8x1	M/34596/5*2)
PUR 3x0,34	5	0,21	M12x1	M/P34594/5*1)

\*1) Straight connector

\*2) 90° Connector

- > Magnetically operated solid state switch - round style
- > IO-Link version available
- > Suitable for all cylinder ranges with magnetic piston
- > Reliable switching with a very fast reponse time
- > Particularly suited for use in high levels of vibration

- > LED indicator as standard
- > CE certified
- > UL listed





### Technical features

#### Operation:

M/50/EAP (PNP) open collector output with LED (yellow)

M/50/EAN (NPN) grounded emitter output with LED (yellow)

M/50/IOP (PNP) Easy IO-Link open collector output with LED (yellow)

#### Switching voltage (Ub):

10 ... 30 V d.c.

#### Switching voltage output:

Ub - 2 V

#### Inducted voltage:

0,5 V

#### Switching current (see graph overleaf):

100 mA max.

#### Switching power:

3,0 W max.

#### Response time:

< 0,5 ms for EAP switch

< = 1 ms for IOP switch

#### Operating frequency:

1 kHz

#### Protection rating (EN 60529):

IP67 (standard)

IP68 for type: M/50/EAP/5U

#### Operating temperature:

-40 ... +80 °C (-40 ... 176 °F)

#### Cable type:

PVC 3 x 0,12 (standard)

PUR 3 x 0,14 (M/50/EAP/5U)

#### Cable length:

2, 5 and 10 m

#### Electromagnetic compatibility according to:

EN 60947-5-2

#### Materials:

Body: plastic

Cable: see table below

#### Technical data - Solid state

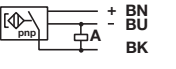
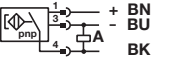
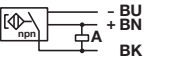
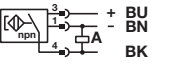
Symbol	Voltage (V d.c.)	Current maximum (mA)	Function	IO-Link *2)	Operating temperature (°C)	LED	Protection class	Plug	Cable length (m)	Cable type	Weight (g)	Model
	10 ... 30	100	PNP	.	-40 ... +80	.	IP67	—	2,5 or 10	PVC 3x0,12	37	M/50/EAP/*V
	10 ... 30	100	PNP	.	-40 ... +80	.	IP67	—	5	PVC 3x0,12	37	M/50/IOP/5V
	10 ... 30	100	PNP	.	-40 ... +80	.	IP68	—	5	PUR 3x0,14	37	M/50/EAP/5U
	10 ... 30	100	PNP	.	-40 ... +80	.	IP67	M8x1	0,3	PVC 3x0,14	16	M/50/EAP/CP *1)
	10 ... 30	100	PNP	.	-40 ... +80	.	IP67	M8x1	0,3	PVC 3x0,14	16	M/50/IOP/CP *1)
	10 ... 30	100	PNP	.	-40 ... +80	.	IP67	M12x1	0,3	PVC 3x0,14	16	M/50/EAP/CC *1)
	10 ... 30	100	NPN	.	-40 ... +80	.	IP67	—	2,5 or 10	PVC 3x0,12	37	M/50/EAN/*V
	10 ... 30	100	NPN	.	-40 ... +80	.	IP67	M8x1	0,3	PVC 3x0,14	16	M/50/EAN/CP *1)

\* Insert cable length; \*1) Plug-in connector below; Color code: BK = black, BN = brown, BU = blue

### IO-Link function \*2)

- Visual installation aid
- Counter
- Temperature diagnostic
- Power LED

### Switching current and switching voltage

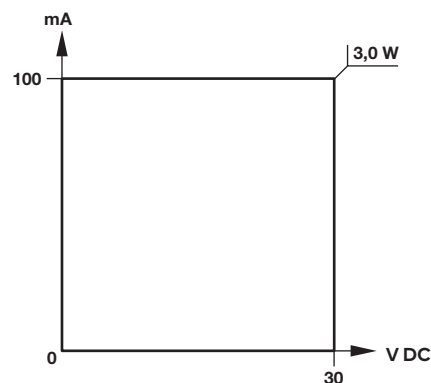

### Dimensions

M/50/EAP/\*V,  
M/50/EAN/\*V  
M/50/IOP/5V  
Cable length L = 2, 5 or 10 m

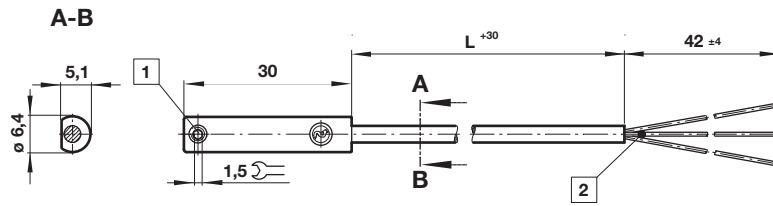

Dimensions in mm  
Projection/First angle



M/50/EAP/CP,  
M/50/EAN/CP  
M/50/IOP/CP

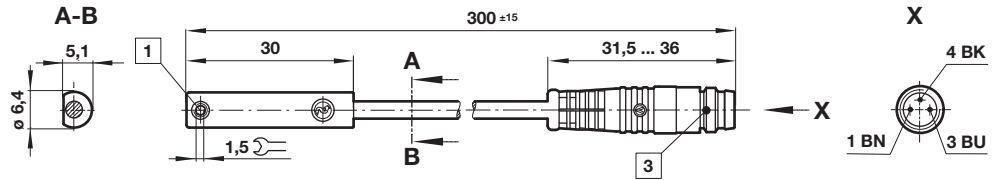

M/50/EAP/CC

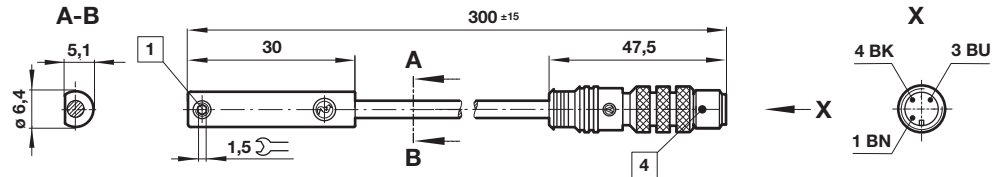

- 1 Fixing screw
- 2 Color code: BK = black; BN = brown; BU = blue
- 3 Plug M8 x 1
- 4 Plug M12 x 1

### Accessories

#### Plug-in connector cable with nut



Outer cover	Cable length (m)	Weight (kg)	Connector	Connector
PVC 3x0,25	5	0,18	M8x1	M/P73001/5*1)
PUR 3x0,25	5	0,18	M8x1	M/P73002/5*1)
PVC 3x0,25	5	0,18	M8x1	M/P34615/5*2)
PUR 3x0,25	5	0,18	M8x1	M/34596/5*2)
PUR 3x0,34	5	0,21	M12x1	M/P34594/5*1)

\*1) Straight connector

\*2) 90° Connector

### QM/27/2/1 – Switch mounting brackets for Round barrel

Switch: M/50



ø	A	B	L	Weight (kg)	Model	ø	A	B	L	Weight (kg)	Model	ø	A	B	L	Weight (kg)	Model
32	9	6	12	0,010	QM/27/2/1	63	7	6	12	0,010	QM/27/2/1	125	-2	-2	12	0,010	QM/27/2/1
40	9	7	12	0,010	QM/27/2/1	80	4	4	12	0,010	QM/27/2/1	160	-10	-9	12	0,010	QM/27/2/1
50	7	5	12	0,010	QM/27/2/1	100	3	2	12	0,010	QM/27/2/1	200	-17	-16	12	0,010	QM/27/2/1

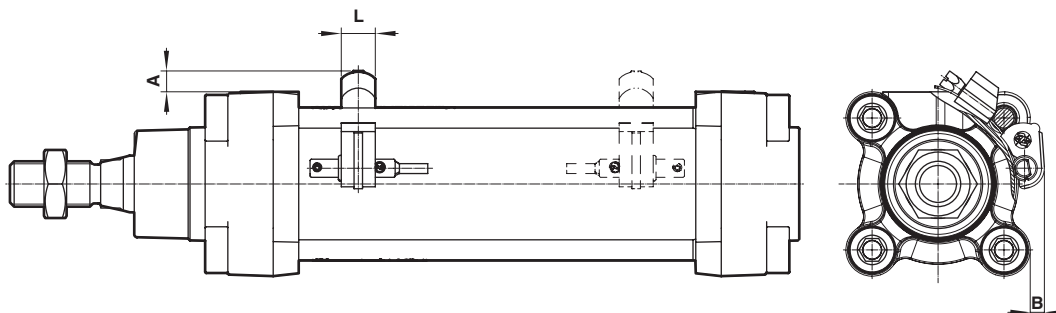

### Warning

These products are intended for use in industrial compressed air systems only. Do not use these products where pressures and temperatures can exceed those listed under »**Technical features/data**«.

Before using these products with fluids other than those specified, for non-industrial applications, life-support systems or other applications not within published specifications, consult Norgren GmbH.

Through misuse, age, or malfunction, components used in fluid power systems can fail in various modes.

The system designer is warned to consider the failure modes of all component parts used in fluid power systems and to provide adequate safeguards to prevent personal injury or damage to equipment in the event of such failure.

System designers must provide a warning to end users in the system instructional manual if protection against a failure mode cannot be adequately provided.

System designers and end users are cautioned to review specific warnings found in instruction sheets packed and shipped with these products.