



CE

Model Number

AIR 16 S Einclipsbar Set

Bearing block for AIR17-S sensor module for installation in TopScan-S profile section

Dimensions

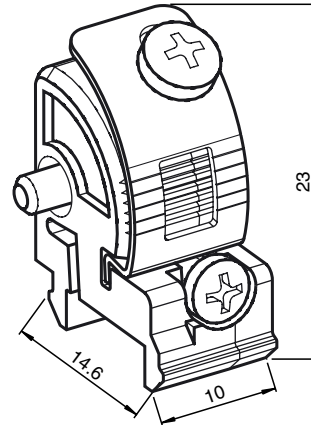

Technical data

Mechanical specifications

Material	Polyamide, spring steel
Mass	approx. 5 g
Mounting	Mounting accessories included

General information

Packing unit	2 item(s)
--------------	-----------

Suitable series

Series	TopScan-S
--------	-----------