

PRODUCT NUMBER
89947-YXXSLF

- LEAD FREE, RoHS COMPLIANT, NOTE 4
- STRAIN RELIEF OPTION, NOTE 5
- TOTAL NB OF POSITIONS, SHEET 2.
- FEATURES, SHEET 2.

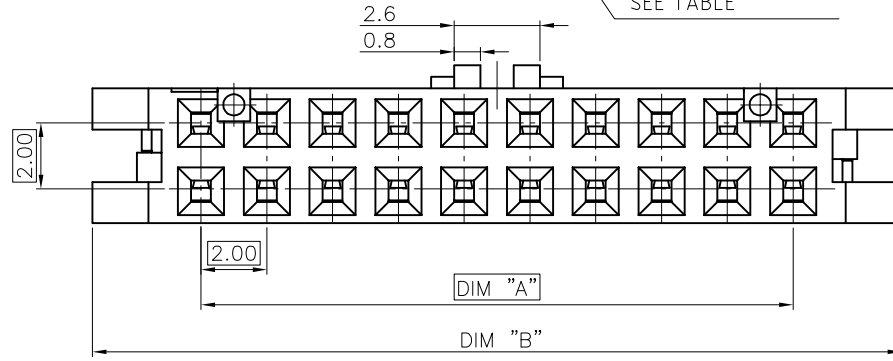
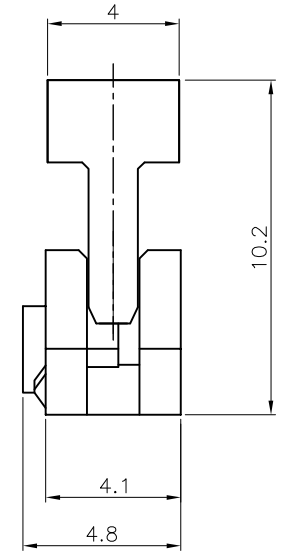
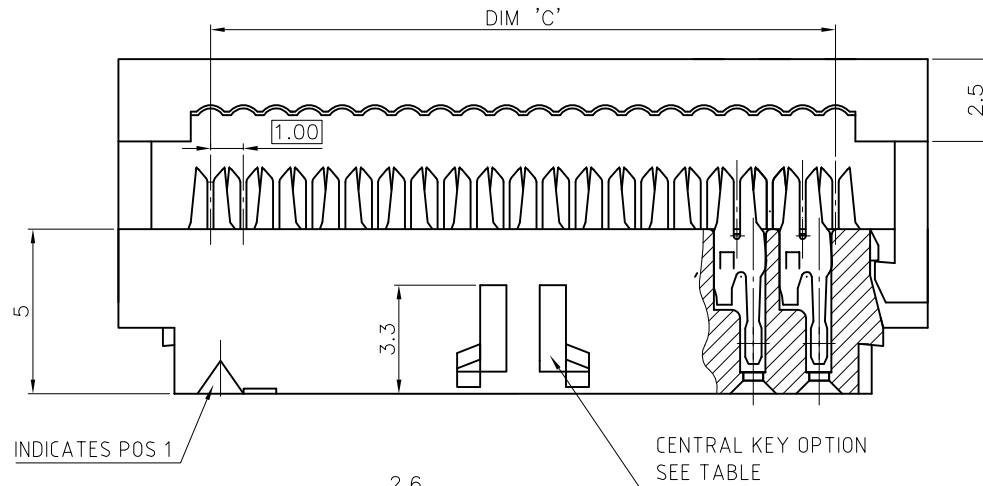

VIEW WITHOUT COVER

mat'l. code SEE NOTE		surface ISO 1302 <input checked="" type="checkbox"/>		tolerance ISO 406 ISO 1101		projection 		product family MINITEK	
L	F06-0211	LMU	06.07.03	tolerances unless otherwise specified		mm		title 2.00mm IDC 0.76µm Au	
M	F07-0215	LMU	07.06.12	angles	linear	scale 1:1		dwg no 89947	
N	F08-0218	J.CO	08.09.09	O'±x'				sheet 1 of 2	
P	F09-0081	J.CO	09.08.27	dr	L.MULIN	07.03.20			size A3
				enr	J.COMPAGNON	07.03.20			
				chr					
				app	JM.C	07.03.20	type Product Customer Drawing		
sheet index	revision sheet	P	P						
		1	2						

FCJ
FCJconnect.com

Copyright FCJ

PRODUCT NUMBER	TOTAL NB OF POS	DIM "A"	DIM "B"	DIM "C"	STRAIN RELIEF OPTION
89947-X06LF	2x3	4	10.6	5	YES
89947-X08LF	2x4	6	12.6	7	YES
89947-X10LF	2x5	8	14.6	9	YES
89947-X12LF	2x6	10	16.6	11	YES
89947-X14LF	2x7	12	18.6	13	YES
89947-X16LF	2x8	14	20.6	15	YES
89947-X18LF	2x9	16	22.6	17	YES
89947-X20LF	2x10	18	24.6	19	YES
89947-X22LF	2x11	20	26.6	21	NOT TOOLED
89947-X24LF	2x12	22	28.6	23	YES
89947-X26LF	2x13	24	30.6	25	YES
89947-X28LF	2x14	26	32.6	27	NOT TOOLED
89947-X30LF	2x15	28	34.6	29	YES
89947-X34LF	2x17	32	38.6	33	YES
89947-X36LF	2x18	34	40.6	35	NOT TOOLED
89947-X40LF	2x20	38	44.6	39	YES
89947-X44LF	2x22	42	48.6	43	YES
89947-X48LF	2x24	46	52.6	47	YES
89947-X50LF	2x25	48	54.6	49	YES

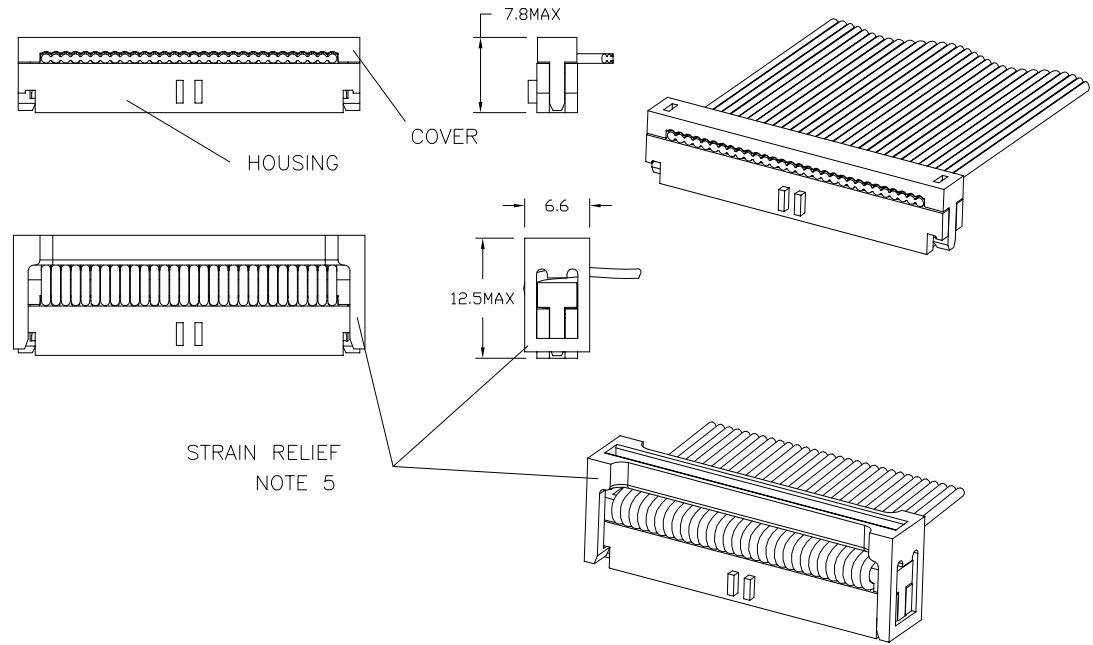

NOTES :

- 1 - MATERIAL : TERMINAL PHOSPHORE BRONZE
BASE AND COVER : PBT GLASSFILLED UL 94V-0 BLACK
- 2 - PLATING : GOLD 0.76µm Au MIN ON CONTACT AREA
NICKEL 1.27µm MIN UNDERPLATING ALL OVER
- 3 - RECOMMENDED CABLE SIZE : AWG28, STRANDED
- 4 - THIS PRODUCT MEETS EUROPEAN UNION DIRECTIVES AND OTHER COUNTRY REGULATIONS AS PER GS-22-008.
PACKAGING SPECIFICATION AS PER GS-14-920.
- 5 - S= STRAIN RELIEF ACCESSORY, SEE TABLE FOR AVAILABILITY,
OMIT LETTER FROM PARTNUMBER IF NOT APPLICABLE.

				AVAILABILITY
89947-7XX			○	FROM 2X3 POS UP TO 2X17
89947-3XX		○		FROM 2x17 POS UP TO 2x25
89947-1XX	○			FROM 2x3 POS UP TO 2x25
PRODUCT CODE	WITHOUT CENTRAL KEY	WITH CENTRAL KEY	WITH CENTRAL KEY AND FRICTION LATCH BUMP	

mat'l. code		surface		tolerance		projection		product family	
SEE NOTE		ISO 1302 ✓		ISO 406 ISO 1101				MINITEK	
ltr	ecn no	dr	date	tolerances unless otherwise specified		mm		title	
L	F06-021	LMU	06.07.03	angles	linear	.0±.3		2.00mm IDC	
M	F07-021	LMU	07.06.12	0°±x'		.00±.13		0.76µm Au	
N	F08-021	J.CO	08.09.09			.000±.05		scale 1:1	
P	F09-008	J.CO	09.08.27	dr	L.MULIN	07.03.20		dwg no	
				chr	J.COMPAGNON	07.03.20		sheet 2 of 2	
				appd	JM.C	07.03.20		size	
								89947	
								type Product Customer Drawing	
sheet index	revision sheet								