



POSITAL

FRABA

IXARC Absolute Rotary Encoder

UCD-S101B-1212-N060-PRQ



Interface

Interface	SSI with Preset
Programming Functions	Absolute: Resolution, Revolution, Code, Preset
Manual Functions	Preset + complement via cable or connector
Interface Cycle Time	≥ 25 μs
Number of Preset Cycles	5,100,000
SSI Format	MMMMMMMMMMMMSSSSSSSSSSSS00
Video Manual	▶ Watch a simple installation video

Outputs

Output Driver	RS422
---------------	-------

Electrical Data

Supply Voltage	4.5 - 30 VDC
Current Consumption	Typical 50 mA
Power Consumption	≤ 1.0 W
Start-Up Time	< 250 ms
Clock Input	RS 422, via Optocoupler
Clock Frequency	100 kHz - 2 MHz
Reverse Polarity Protection	Yes
Short Circuit Protection	Yes
EMC: Emitted Interference	DIN EN 61000-6-4

Data Sheet

Printed at 28-09-2017 00:09



POSITAL

FRABA

EMC: Noise Immunity	DIN EN 61000-6-2
MTTF	350 years @ 40 °C

Sensor

Technology	Magnetic
Resolution Singleturn	12 bit
Resolution Multiturn	12 bit
Multiturn Technology	Self powered magnetic pulse counter (no battery, no gear)
Accuracy (INL)	$\pm 0.0878^\circ$ (≤ 12 bit)
Sense Signal (Default)	Clockwise shaft movement (front view on shaft)
Code	Binary

Environmental Specifications

Protection Class (Shaft)	IP65
Protection Class (Housing)	IP65
Operating Temperature	-40 °C (-40 °F) - +85 °C (+185 °F)
Humidity	98% RH, no condensation

Mechanical Data

Housing Material	Steel
Housing Coating	Cathodic corrosion protection (>720 hrs salt spray resistance)
Flange Type	Synchro, \varnothing 58 mm (N)
Flange Material	Aluminum
Shaft Type	Solid, Length = 10 mm
Shaft Diameter	\varnothing 6 mm (0.24")
Shaft Material	Stainless Steel V2A (1.4305, 303)
Max. Shaft Load	Axial 40 N, Radial 110 N
Minimum Mechanical Lifetime (10 ⁸ revolutions with Fa/Fr)	550 (20 N / 40 N), 195 (40 N / 60 N), 135 (40 N / 80 N), 85 (40 N / 110 N)
Rotor Inertia	≤ 30 gcm ² [≤ 0.17 oz-in ²]
Friction Torque	≤ 3 Ncm @ 20 °C (4.2 oz-in @ 68 °F)
Max. Permissible Mechanical Speed	≤ 12000 1/min
Shock Resistance	≤ 100 g (half sine 6 ms, EN 60068-2-27)
Permanent Shock Resistance	≤ 10 g (half sine 16 ms, EN 60068-2-29)
Vibration Resistance	≤ 10 g (10 Hz - 1000 Hz, EN 60068-2-6)
Length	39 mm (1.54")

Data Sheet

Printed at 28-09-2017 00:09



POSITAL

FRABA

Weight 215 g (0.47 lb)

Electrical Connection

Connection Orientation Radial
Connector M12, Male, 8 pin, a coded

Certification

Approval CE + cULus listed, Industrial Control Equipment
Product Life Cycle Established

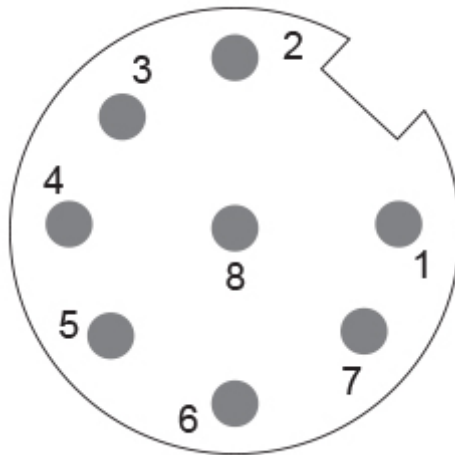

Connection Plan

SIGNAL	PIN NUMBER
Power Supply	2
GND	1
Data+	5
Data-	6
Clock+	3
Clock-	4
Preset	7
DIR	8
Shielding	Connector Housing

Connector-View on Encoder
Rotation Clockwise (seen on shaft)



POSITAL

FRABA

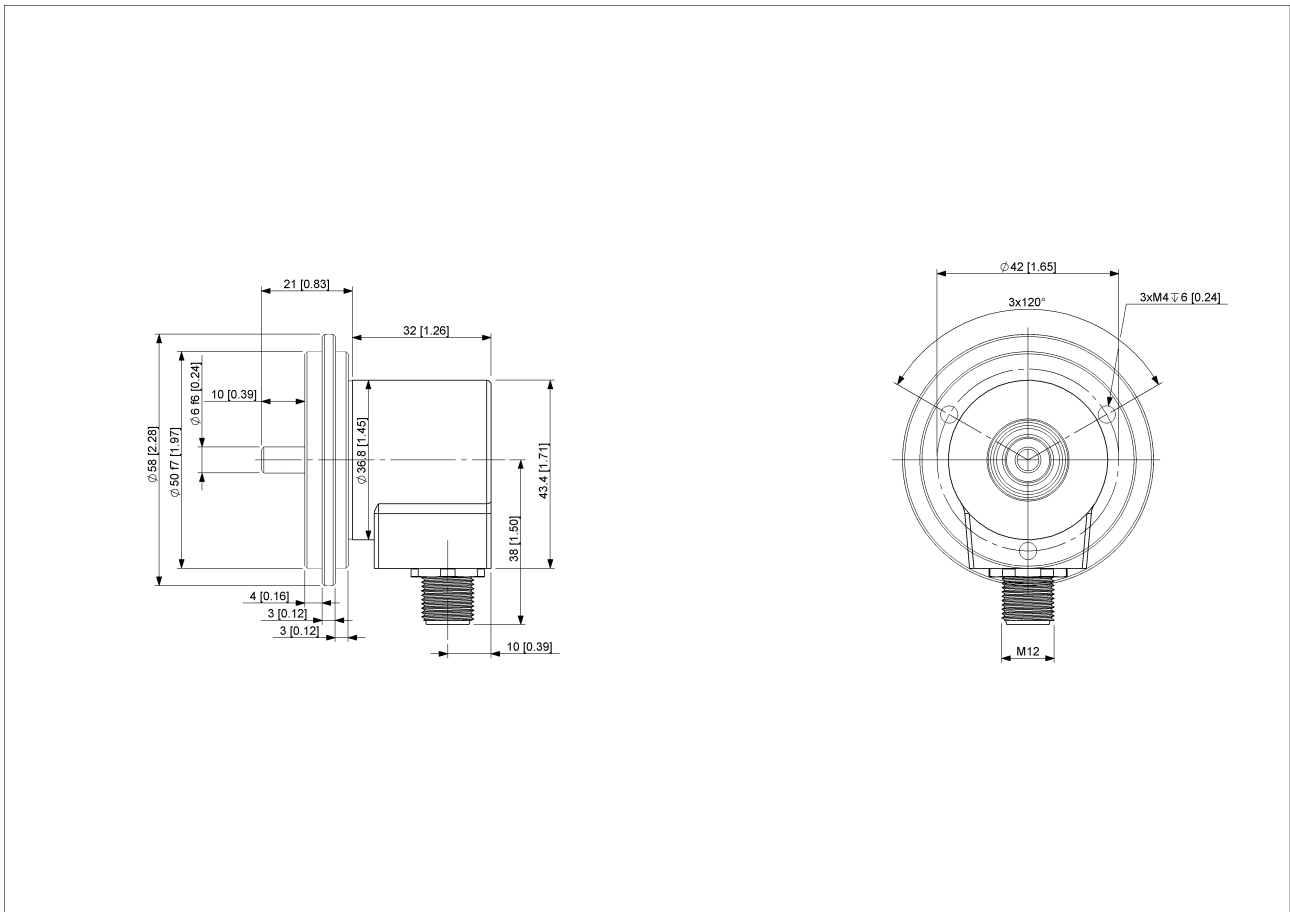

[2D Drawing](#)

Accessories

Connectors & Cables

- 5m PUR Cable, 8pin, A-Coded, f
- 10m PUR Cable, 8pin, A-Coded, f
- 2m PUR Cable, 8pin, A-Coded, f
- 10m PUR Cable, 8pin, A-Coded, f
- M12, 8pin A-Coded, Female
- More

- Clamp Disc w/ Eccentric Hole-4pcs
- Clamp Disc w/ Centred Hole-4pcs

- Coupling Bellow Type-06-06
- Coupling Bellow Type-06-10
- Coupling Bellow Type-06-08
- Coupling Bellow Type-06-(3/8")

Data Sheet

Printed at 28-09-2017 00:09



POSITAL

FRABA

Coupling Bellow Type-06-(1/4")
Coupling Jaw Type-06-06
Coupling Jaw Type-06-10
Coupling Jaw Type-06-08
Coupling Jaw Type-06-12
Coupling Jaw Type-06-(1/4")
Coupling Jaw Type-06-(3/8")
Coupling Disc Type-06-06
Coupling Disc Type-06-10
More

Mounting Bracket for Synchro Flange w/ fixtures

Contact



POSITAL
Contact Us

The picture and drawing are for general presentation purposes only. Please refer to the "Download" section for detailed technical drawings.
All dimension in [inch] mm. © FRABA B.V., All rights reserved. We do not assume responsibility for technical inaccuracies or omissions.
Specifications are subject to change without notice.