

Category 5e Keystone Panel Mount Coupler



Category 5e Unshielded Keystone Panel Mount Coupler (FACK4BKPM)

Features

- High performance data throughput, meets Category 5e data transfer rates
- Easily mounted into panels of virtually any thickness
- Die cast adaptor is robust and ensures easy mounting (into standard cut-out) and reliable earthing

Specifications

- Dimensions: 35.5 x 19.12 x 29.54mm approx. (H x W x D)
- Assembled weight (without screws): 14g approx.
- Colour: **Coupler:** Black **Panel mount:** Silver
- Material: **Coupler:**
 Housing ABS UL90V-0 **Panel mount adaptor:** Zinc
 Contacts: 50µ"/ 1.27µm gold plating over nickel plated phosphor bronze
- Supplied with 2 pairs of screws
 2 x round head nickel plated steel self-tapping screws
 2 x round head (4.40 x 1/4") machine screws
- For more detailed coupler specification please see webpage below:
http://www.tuk.co.uk/tuk_live/product_details.php?category_id=&pld=438

Packaging: Supplied as a kit in individual polythene bags, then in bags of 20

Commodity Code: 85444920

EAN Number: 5055386507662

ROHS Compliant

Code: KAPMA#20

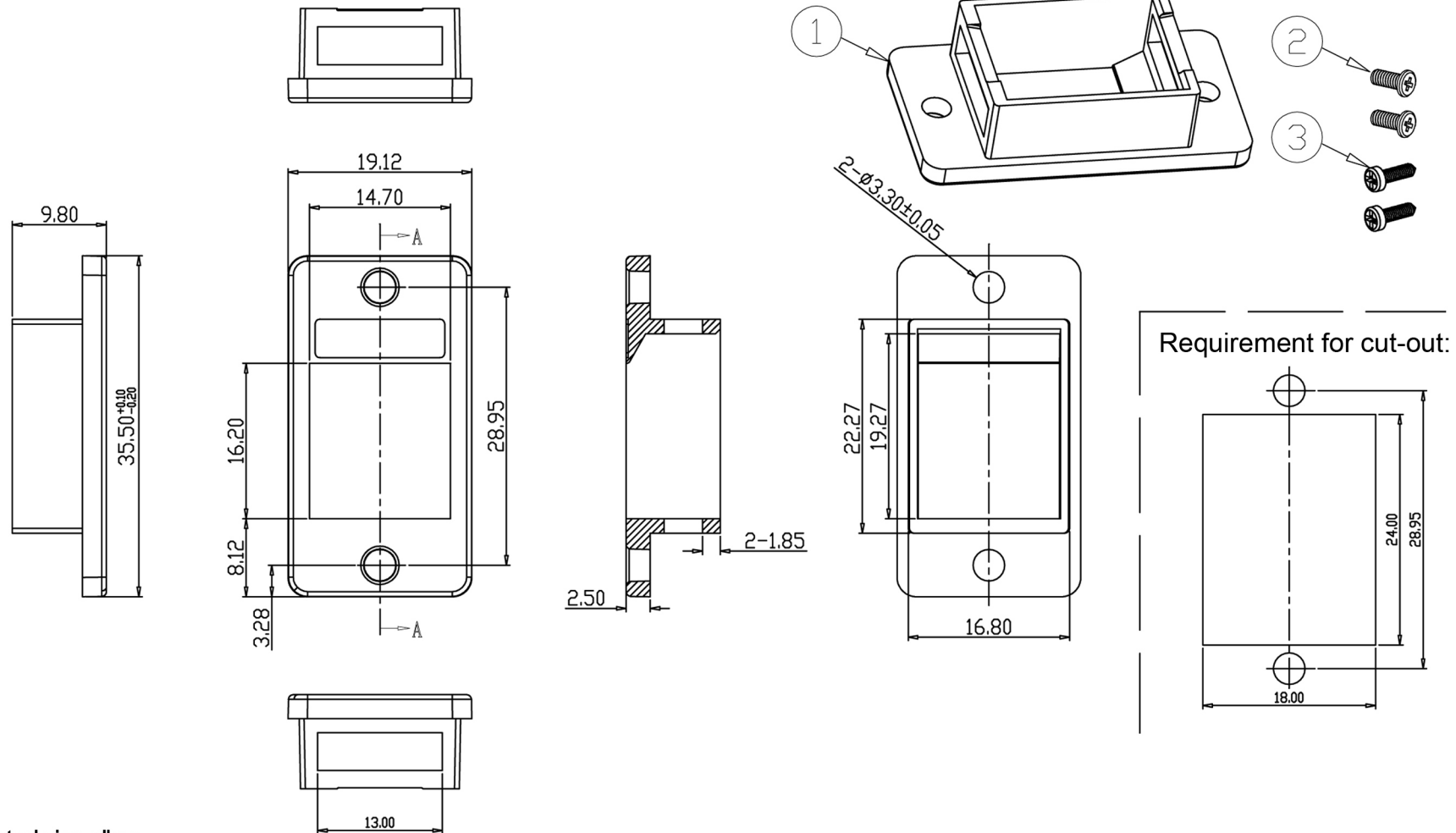

Materials:

- 1. Nickel plated zinc alloy
- 2&3. Nickel plated steel

ROHS Compliant

Code: FACK4bk/wh

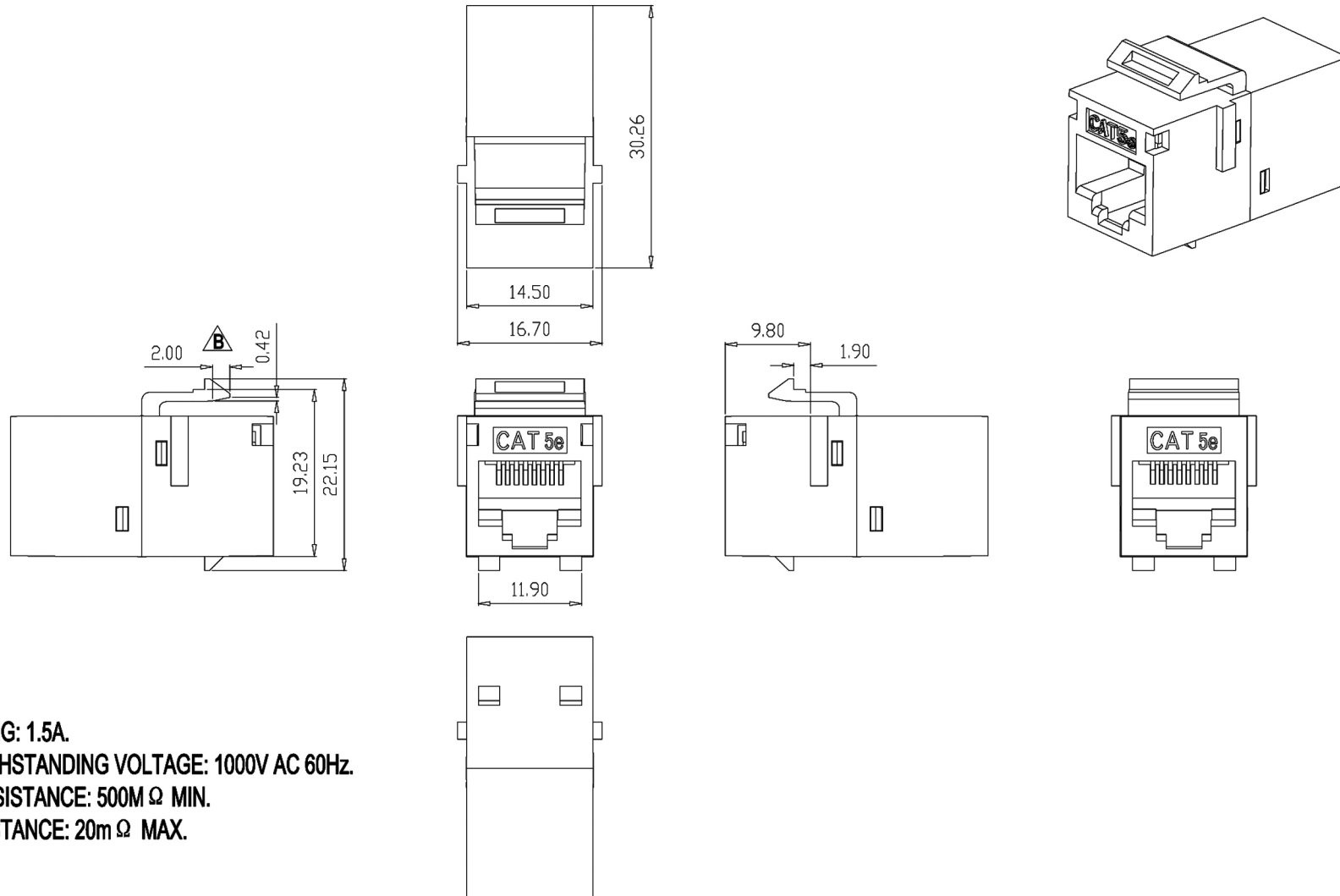

ELECTRICAL

CURRENT RATING: 1.5A.
DIELECTRIC WITHSTANDING VOLTAGE: 1000V AC 60Hz.
INSULATION RESISTANCE: 500M Ω MIN.
CONTACT RESISTANCE: 20m Ω MAX.

MECHANICAL

(1)Materials:ABS+PC V0
 (2)RJ45 Jack Contact: 50 μ "/ 1.27 μ m gold plating over nickel plated phosphor bronze