



DC COMPONENTS CO., LTD.

DISCRETE SEMICONDUCTORS

BC337

TECHNICAL SPECIFICATIONS OF NPN EPITAXIAL PLANAR TRANSISTOR

Description

Designed for driver and output stage of audio amplifiers.

Pinning

- 1 = Collector
- 2 = Base
- 3 = Emitter

Absolute Maximum Ratings (TA=25°C)

Characteristic	Symbol	Rating	Unit
Collector-Base Voltage	V <sub>CB0</sub>	50	V
Collector-Emitter Voltage	V <sub>CE0</sub>	45	V
Emitter-Base Voltage	V <sub>EB0</sub>	5	V
Collector Current	I <sub>C</sub>	800	mA
Total Power Dissipation	P <sub>D</sub>	625	mW
Junction Temperature	T <sub>J</sub>	+150	°C
Storage Temperature	T <sub>STG</sub>	-55 to +150	°C

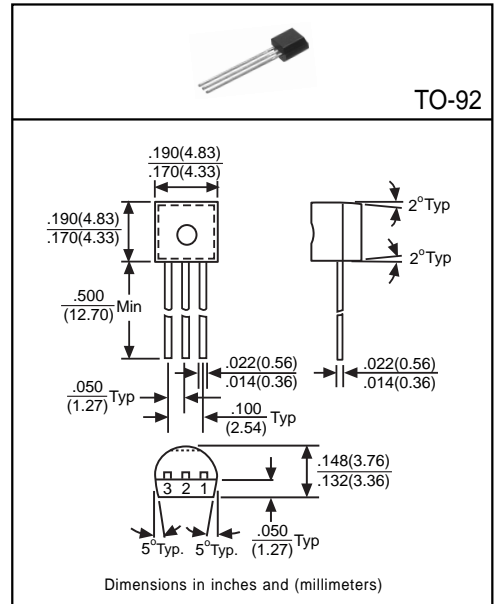

Electrical Characteristics

(Ratings at 25°C ambient temperature unless otherwise specified)

Characteristic	Symbol	Min	Typ	Max	Unit	Test Conditions
Collector-Base Breakdown Voltage	BV <sub>CB0</sub>	50	-	-	V	I <sub>C</sub> =100μA, I <sub>E</sub> =0
Collector-Emitter Breakdown Voltage	BV <sub>CE0</sub>	45	-	-	V	I <sub>C</sub> =10mA, I <sub>B</sub> =0
Emitter-Base Breakdown Voltage	BV <sub>EB0</sub>	5	-	-	V	I <sub>E</sub> =10μA, I <sub>C</sub> =0
Collector Cutoff Current	I <sub>CBO</sub>	-	-	0.1	μA	V <sub>CB</sub> =45V, I <sub>E</sub> =0
Collector-Emitter Saturation Voltage <sup>(1)</sup>	V <sub>CE(sat)</sub>	-	-	0.7	V	I <sub>C</sub> =500mA, I <sub>B</sub> =50mA
Base-Emitter On Voltage <sup>(1)</sup>	V <sub>BE(on)</sub>	-	-	1.2	V	I <sub>C</sub> =300mA, V <sub>CE</sub> =1V
DC Current Gain <sup>(1)</sup>	h <sub>FE1</sub>	100	-	630	-	I <sub>C</sub> =100mA, V <sub>CE</sub> =1V
	h <sub>FE2</sub>	40	-	-	-	I <sub>C</sub> =300mA, V <sub>CE</sub> =1V
Transition Frequency	f <sub>T</sub>	-	210	-	MHz	I <sub>C</sub> =10mA, V <sub>CE</sub> =5V, f=100MHz
Output Capacitance	C <sub>ob</sub>	-	4	-	pF	V <sub>CB</sub> =10V, f=1MHz, I <sub>E</sub> =0

(1)Pulse Test: Pulse Width ≤ 380μs, Duty Cycle ≤ 2%

Classification of h<sub>FE1</sub>

Rank	16	25	40
Range	100~250	160~400	250~630

## Electrical Characteristic Curves

### Typical Output Characteristics

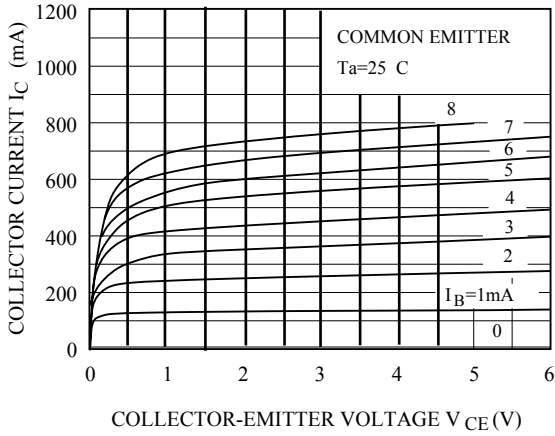

### DC Current Gain

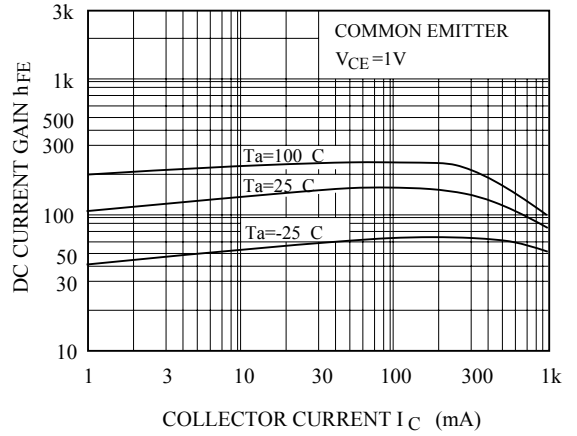

### Collector-Emitter Saturation Voltage

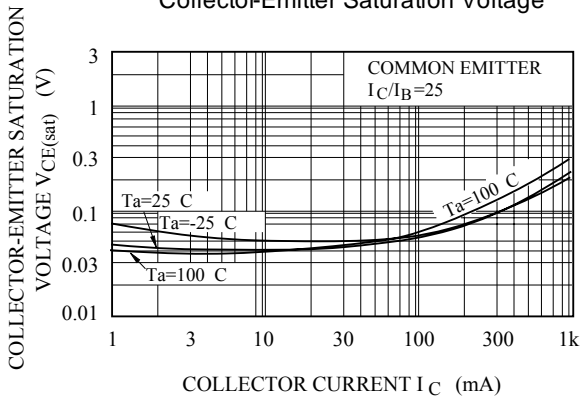

### Current Gain-Bandwidth Product

