

DI5023

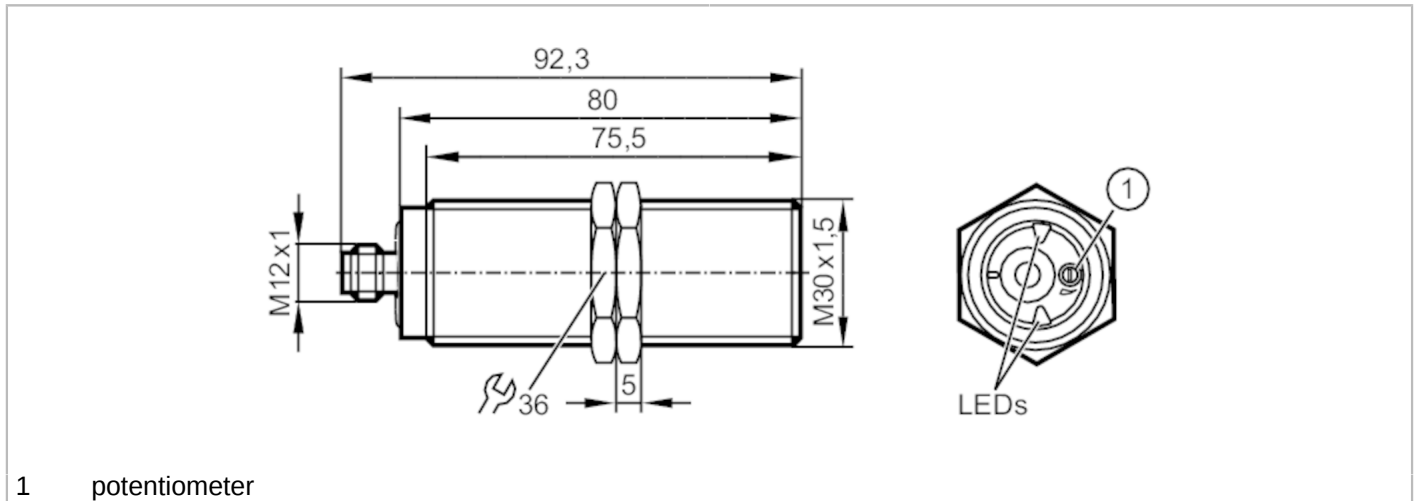

Compact evaluation unit for speed monitoring

DIA3010-ZPKG/US



1 potentiometer



Product characteristics		
Electrical design		PNP
Output function		normally open
Sensing range	[mm]	10
Housing		threaded type
Dimensions	[mm]	M30 x 1.5 / L = 92.3
Application		
Application		simple evaluation of rotating and linear movement with regard to underspeed; blocking
Electrical data		
Nominal voltage DC	[V]	10...36
Current consumption	[mA]	< 20
Protection class		III
Reverse polarity protection		yes
Outputs		
Total number of outputs		1
Electrical design		PNP
Output function		normally open
Max. voltage drop switching output DC	[V]	2.5
Permanent current rating of switching output DC	[mA]	250
Short-time current rating of switching output	[mA]	250
Short-circuit proof		yes
Overload protection		yes
Detection zone		
Sensing range	[mm]	10
Sensing range adjustable		no
Operating distance	[mm]	0...8.1

DI5023



Compact evaluation unit for speed monitoring

DIA3010-ZPKG/US

Measuring/setting range		
Setting range	[Imp/min]	5...3600
Accuracy / deviations		
Correction factor		steel: 1 / stainless steel: 0.7 / brass: 0.5 / aluminium: 0.4 / copper: 0.3
Hysteresis	[% of Sr]	10
Response times		
Start-up delay	[s]	15
Max. damping frequency	[Imp/min]	18000
Software / programming		
Adjustment of the switch point		multiturn potentiometer
Operating conditions		
Ambient temperature	[°C]	-25...80
Protection		IP 65; IP 67
Tests / approvals		
EMC		EN 60947-5-2
Shock resistance		DIN EN 60947-5-2
Vibration resistance		DIN EN 60947-5-2
MTTF	[years]	3262
Mechanical data		
Weight	[g]	252
Housing		threaded type
Mounting		flush mountable
Dimensions	[mm]	M30 x 1.5 / L = 92.3
Thread designation		M30 x 1.5
Materials		brass special coating; PA; stainless steel; TPE-U
Tightening torque	[Nm]	50
Displays / operating elements		
Display	switching status	1 x LED, green
Accessories		
Accessories (supplied)		lock nuts: 2
Electrical connection		

Connector: 1 x M12

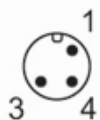

DI5023



Compact evaluation unit for speed monitoring

DIA3010-ZPKG/US

Connection

