



PIC32MZ Embedded Connectivity with Floating Point Unit (EF) Family

32-bit MCUs (up to 2 MB Live-Update Flash and 512 KB SRAM) with FPU, Audio and Graphics Interfaces, HS USB, Ethernet, and Advanced Analog

Operating Conditions

- 2.1V to 3.6V, -40°C to +85°C, DC to 200 MHz
- 2.1V to 3.6V, -40°C to +125°C (Planned)

Core: 200 MHz (up to 330 DMIPS) M-Class

- 16 KB I-Cache, 4 KB D-Cache
- FPU for fast single- and double-precision math
- MMU for optimum embedded OS execution
- microMIPS™ mode for up to 35% smaller code size
- DSP-enhanced core:
 - Four 64-bit accumulators
 - Single-cycle MAC, saturating, and fractional math
 - IEEE 754-compliant
- Code-efficient (C and Assembly) architecture

Clock Management

- Programmable PLLs and oscillator clock sources
- Fail-Safe Clock Monitor (FSCM)
- Independent Watchdog Timers (WDT) and Deadman Timer (DMT)
- Fast wake-up and start-up

Power Management

- Low-power modes (Sleep and Idle)
- Integrated Power-on Reset (POR) and Brown-out Reset (BOR)

Memory Interfaces

- 50 MHz External Bus Interface (EBI)
- 50 MHz Serial Quad Interface (SQI)

Audio and Graphics Interfaces

- Graphics interfaces: EBI or PMP
- Audio data communication: I²S, LJ, and RJ
- Audio control interfaces: SPI and I²C™
- Audio master clock: Fractional clock frequencies with USB synchronization

High-Speed (HS) Communication Interfaces (with Dedicated DMA)

- USB 2.0-compliant Hi-Speed On-The-Go (OTG) controller
- 10/100 Mbps Ethernet MAC with MII and RMII interface

Security Features

- Crypto Engine with RNG for data encryption/decryption and authentication (AES, 3DES, SHA, MD5, and HMAC)
- Advanced memory protection:
 - Peripheral and memory region access control

Direct Memory Access (DMA)

- Eight channels with automatic data size detection
- Programmable Cyclic Redundancy Check (CRC)

Packages

| Type | QFN | | TQFP | | | VTLA | LQFP |
|--------------------|------------|------------|------------|------------|------------|------------|---------------|
| Pin Count | 64 | 64 | 100 | 144 | 124 | 144 | |
| I/O Pins (up to) | 53 | 53 | 78 | 120 | 98 | 120 | |
| Contact/Lead Pitch | 0.50 mm | 0.50 mm | 0.40 mm | 0.50 mm | 0.40 mm | 0.50 mm | 0.50 mm |
| Dimensions | 9x9x0.9 mm | 10x10x1 mm | 12x12x1 mm | 14x14x1 mm | 16x16x1 mm | 9x9x0.9 mm | 20x20x1.40 mm |

Advanced Analog Features

- 12-bit ADC module:
 - 18 Msps with up to six Sample and Hold (S&H) circuits (five dedicated and one shared)
 - Up to 48 analog inputs
 - Can operate during Sleep and Idle modes
 - Multiple trigger sources
 - Six Digital Comparators and six Digital Filters
- Two comparators with 32 programmable voltage references
- Temperature sensor with ±2°C accuracy

Communication Interfaces

- Two CAN modules (with dedicated DMA channels):
 - 2.0B Active with DeviceNet™ addressing support
- Six UART modules (25 Mbps):
 - Supports up to LIN 2.1 and IrDA® protocols
- Six 4-wire SPI modules (up to 50 MHz)
- SQI configurable as an additional SPI module (50 MHz)
- Five I²C modules (up to 1 Mbaud) with SMBus support
- Parallel Master Port (PMP)
- Peripheral Pin Select (PPS) to enable function remap

Timers/Output Compare/Input Capture

- Nine 16-bit or up to four 32-bit timers/counters
- Nine Output Compare (OC) modules
- Nine Input Capture (IC) modules
- Real-Time Clock and Calendar (RTCC) module

Input/Output

- 5V-tolerant pins with up to 32 mA source/sink
- Selectable open drain, pull-ups, pull-downs, and slew rate controls
- External interrupts on all I/O pins
- PPS to enable function remap

Qualification and Class B Support

- AEC-Q100 REVG (Grade 1 -40°C to +125°C) Planned
- Class B Safety Library, IEC 60730
- Back-up internal oscillator

Debugger Development Support

- In-circuit and in-application programming
- 4-wire MIPS® Enhanced JTAG interface
- Unlimited software and 12 complex breakpoints
- IEEE 1149.2-compatible (JTAG) boundary scan
- Non-intrusive hardware-based instruction trace

Software and Tools Support

- C/C++ compiler with native DSP/fractional and FPU support
- MPLAB® Harmony Integrated Software Framework
- TCP/IP, USB, Graphics, and mTouch™ middleware
- MFi, Android™, and Bluetooth® audio frameworks
- RTOS Kernels: Express Logic ThreadX, FreeRTOS™, OPENRTOS®, Micrium® µC/OS™, and SEGGER embOS®

TABLE 1: PIC32MZ EF FAMILY FEATURES

| Device | Program Memory (KB) | Data Memory (KB) | Pins | Packages | Boot Flash Memory (KB) | Remappable Peripherals | | | | | Crypto | RNG | DMA Channels (Programmable/Dedicated) | ADC (Channels) | Analog Comparators | USB 2.0 HS OTG | I ² C™ | PMP | EBI | SQI | RTCC | Ethernet | I/O Pins | JTAG | Trace | |
|-------------------|---------------------|------------------|------|------------|------------------------|------------------------|---------------------------------------|------|----------------------|------------------------------------|--------|------|---------------------------------------|----------------|--------------------|----------------|-------------------|-----|-----|-----|------|----------|----------|------|-------|----------|
| | | | | | | Remappable Pins | Timers/Capture/Compare ⁽¹⁾ | UART | SPI/I ² S | External Interrupts ⁽²⁾ | | | | | | | | | | | | | | | | CAN 2.0B |
| PIC32MZ0512EFE064 | 512 | 128 | 64 | TQFP, QFN | 160 | 34 | 9/9/9 | 6 | 4 | 5 | 0 | N | Y | 8/12 | 24 | 2 | Y | 4 | Y | N | Y | Y | Y | 46 | Y | Y |
| PIC32MZ0512EFF064 | | | | | | | | | | | 2 | N | Y | 8/16 | | | | | | | | | | | | |
| PIC32MZ0512EFK064 | 2 | Y | | | | | | | | | Y | 8/18 | | | | | | | | | | | | | | |
| PIC32MZ1024EFE064 | 1024 | 256 | | | | | | | | | 0 | N | Y | 8/12 | | | | | | | | | | | | |
| PIC32MZ1024EFF064 | | | | | | | | | | | 2 | N | Y | 8/16 | | | | | | | | | | | | |
| PIC32MZ1024EFK064 | | | | | | | | | | | 2 | Y | Y | 8/18 | | | | | | | | | | | | |
| PIC32MZ0512EFE100 | 512 | 128 | 100 | TQFP | 160 | 51 | 9/9/9 | 6 | 6 | 5 | 0 | N | Y | 8/12 | 40 | 2 | Y | 5 | Y | Y | Y | Y | 78 | Y | Y | |
| PIC32MZ0512EFF100 | | | | | | | | | | | 2 | N | Y | 8/16 | | | | | | | | | | | | |
| PIC32MZ0512EFK100 | 2 | Y | | | | | | | | | Y | 8/18 | | | | | | | | | | | | | | |
| PIC32MZ1024EFE100 | 1024 | 256 | | | | | | | | | 0 | N | Y | 8/12 | | | | | | | | | | | | |
| PIC32MZ1024EFF100 | | | | | | | | | | | 2 | N | Y | 8/16 | | | | | | | | | | | | |
| PIC32MZ1024EFK100 | | | | | | | | | | | 2 | Y | Y | 8/18 | | | | | | | | | | | | |
| PIC32MZ0512EFE124 | 512 | 128 | 124 | VTLA | 160 | 53 | 9/9/9 | 6 | 6 | 5 | 0 | N | Y | 8/12 | 48 | 2 | Y | 5 | Y | Y | Y | Y | 97 | Y | Y | |
| PIC32MZ0512EFF124 | | | | | | | | | | | 2 | N | Y | 8/16 | | | | | | | | | | | | |
| PIC32MZ0512EFK124 | 2 | Y | | | | | | | | | Y | 8/18 | | | | | | | | | | | | | | |
| PIC32MZ1024EFE124 | 1024 | 256 | | | | | | | | | 0 | N | Y | 8/12 | | | | | | | | | | | | |
| PIC32MZ1024EFF124 | | | | | | | | | | | 2 | N | Y | 8/16 | | | | | | | | | | | | |
| PIC32MZ1024EFK124 | | | | | | | | | | | 2 | Y | Y | 8/18 | | | | | | | | | | | | |
| PIC32MZ0512EFE144 | 512 | 128 | 144 | LQFP, TQFP | 160 | 53 | 9/9/9 | 6 | 6 | 5 | 0 | N | Y | 8/12 | 48 | 2 | Y | 5 | Y | Y | Y | Y | 120 | Y | Y | |
| PIC32MZ0512EFF144 | | | | | | | | | | | 2 | N | Y | 8/16 | | | | | | | | | | | | |
| PIC32MZ0512EFK144 | 2 | Y | | | | | | | | | Y | 8/18 | | | | | | | | | | | | | | |
| PIC32MZ1024EFE144 | 1024 | 256 | | | | | | | | | 0 | N | Y | 8/12 | | | | | | | | | | | | |
| PIC32MZ1024EFF144 | | | | | | | | | | | 2 | N | Y | 8/16 | | | | | | | | | | | | |
| PIC32MZ1024EFK144 | | | | | | | | | | | 2 | Y | Y | 8/18 | | | | | | | | | | | | |

Note 1: Eight out of nine timers are remappable.

Note 2: Four out of five external interrupts are remappable.

TABLE 1: PIC32MZ EF FAMILY FEATURES (CONTINUED)

| Device | Program Memory (KB) | Data Memory (KB) | Pins | Packages | Boot Flash Memory (KB) | Remappable Peripherals | | | | | Crypto | RNG | DMA Channels (Programmable/Dedicated) | ADC (Channels) | Analog Comparators | USB 2.0 HS OTG | I ² C™ | PMP | EBI | SQI | RTCC | Ethernet | I/O Pins | JTAG | Trace | |
|-------------------|---------------------|------------------|------|------------|------------------------|------------------------|---------------------------------------|------|----------------------|------------------------------------|--------|-----|---------------------------------------|----------------|--------------------|----------------|-------------------|-----|-----|-----|------|----------|----------|------|-------|----------|
| | | | | | | Remappable Pins | Timers/Capture/Compare ⁽¹⁾ | UART | SPI/I ² S | External Interrupts ⁽²⁾ | | | | | | | | | | | | | | | | CAN 2.0B |
| PIC32MZ1024EFG064 | 1024 | 512 | 64 | TQFP, QFN | 160 | 34 | 9/9/9 | 6 | 4 | 5 | 0 | N | Y | 8/12 | 24 | 2 | Y | 4 | Y | N | Y | Y | Y | 46 | Y | Y |
| PIC32MZ1024EFH064 | | | | | | | | | | | 2 | N | Y | 8/16 | | | | | | | | | | | | |
| PIC32MZ1024EFM064 | | | | | | | | | | | 2 | Y | Y | 8/18 | | | | | | | | | | | | |
| PIC32MZ2048EFG064 | | | | | | | | | | | 0 | N | Y | 8/12 | | | | | | | | | | | | |
| PIC32MZ2048EFH064 | | | | | | | | | | | 2 | N | Y | 8/16 | | | | | | | | | | | | |
| PIC32MZ2048EFM064 | | | | | | | | | | | 2 | Y | Y | 8/18 | | | | | | | | | | | | |
| PIC32MZ1024EFG100 | 1024 | 512 | 100 | TQFP | 160 | 51 | 9/9/9 | 6 | 6 | 5 | 0 | N | Y | 8/12 | 40 | 2 | Y | 5 | Y | Y | Y | Y | 78 | Y | Y | |
| PIC32MZ1024EFH100 | | | | | | | | | | | 2 | N | Y | 8/16 | | | | | | | | | | | | |
| PIC32MZ1024EFM100 | | | | | | | | | | | 2 | Y | Y | 8/18 | | | | | | | | | | | | |
| PIC32MZ2048EFG100 | | | | | | | | | | | 0 | N | Y | 8/12 | | | | | | | | | | | | |
| PIC32MZ2048EFH100 | | | | | | | | | | | 2 | N | Y | 8/16 | | | | | | | | | | | | |
| PIC32MZ2048EFM100 | | | | | | | | | | | 2 | Y | Y | 8/18 | | | | | | | | | | | | |
| PIC32MZ1024EFG124 | 1024 | 512 | 124 | VTLA | 160 | 53 | 9/9/9 | 6 | 6 | 5 | 0 | N | Y | 8/12 | 48 | 2 | Y | 5 | Y | Y | Y | Y | 97 | Y | Y | |
| PIC32MZ1024EFH124 | | | | | | | | | | | 2 | N | Y | 8/16 | | | | | | | | | | | | |
| PIC32MZ1024EFM124 | | | | | | | | | | | 2 | Y | Y | 8/18 | | | | | | | | | | | | |
| PIC32MZ2048EFG124 | | | | | | | | | | | 0 | N | Y | 8/12 | | | | | | | | | | | | |
| PIC32MZ2048EFH124 | | | | | | | | | | | 2 | N | Y | 8/16 | | | | | | | | | | | | |
| PIC32MZ2048EFM124 | | | | | | | | | | | 2 | Y | Y | 8/18 | | | | | | | | | | | | |
| PIC32MZ1024EFG144 | 1024 | 512 | 144 | LQFP, TQFP | 160 | 53 | 9/9/9 | 6 | 6 | 5 | 0 | N | Y | 8/12 | 48 | 2 | Y | 5 | Y | Y | Y | Y | 120 | Y | Y | |
| PIC32MZ1024EFH144 | | | | | | | | | | | 2 | N | Y | 8/16 | | | | | | | | | | | | |
| PIC32MZ1024EFM144 | | | | | | | | | | | 2 | Y | Y | 8/18 | | | | | | | | | | | | |
| PIC32MZ2048EFG144 | | | | | | | | | | | 0 | N | Y | 8/12 | | | | | | | | | | | | |
| PIC32MZ2048EFH144 | | | | | | | | | | | 2 | N | Y | 8/16 | | | | | | | | | | | | |
| PIC32MZ2048EFM144 | | | | | | | | | | | 2 | Y | Y | 8/18 | | | | | | | | | | | | |

Note 1: Eight out of nine timers are remappable.
2: Four out of five external interrupts are remappable.

PIC32MZ Embedded Connectivity with Floating Point Unit (EF) Family

Device Pin Tables

TABLE 2: PIN NAMES FOR 64-PIN DEVICES

| 64-PIN QFN ⁽⁴⁾ AND TQFP (TOP VIEW) | | | |
|---|--------------------------------------|-------|--|
| <p>PIC32MZ0512EF(E/F/K)064 PIC32MZ1024EF(G/H/M)064 PIC32MZ1024EF(E/F/K)064 PIC32MZ2048EF(G/H/M)064</p> | | | |
| Pin # | Full Pin Name | Pin # | Full Pin Name |
| 1 | AN17/ETXEN/RPE5/PMD5/RE5 | 33 | VBUS |
| 2 | AN16/ETXD0/PMD6/RE6 | 34 | VUSB3v3 |
| 3 | AN15/ETXD1/PMD7/RE7 | 35 | Vss |
| 4 | AN14/C1IND/RPG6/SCK2/PMA5/RG6 | 36 | D- |
| 5 | AN13/C1INC/RPG7/SDA4/PMA4/RG7 | 37 | D+ |
| 6 | AN12/C2IND/RPG8/SCL4/PMA3/RG8 | 38 | RPF3/USBID/RF3 |
| 7 | Vss | 39 | VDD |
| 8 | VDD | 40 | Vss |
| 9 | MCLR | 41 | RPF4/SDA5/PMA9/RF4 |
| 10 | AN11/C2INC/RPG9/PMA2/RG9 | 42 | RPF5/SCL5/PMA8/RF5 |
| 11 | AN45/C1INA/RPB5/RB5 | 43 | AERXD0/ETXD2/RPD9/SDA1/PMCS2/PMA15/RD9 |
| 12 | AN4/C1INB/RB4 | 44 | ECOL/RPD10/SCL1/SCK4/RD10 |
| 13 | AN3/C2INA/RPB3/RB3 | 45 | AERXCLK/AEREFCLK/ECRS/RPD11/PMCS1/PMA14/RD11 |
| 14 | AN2/C2INB/RPB2/RB2 | 46 | AERXD1/ETXD3/RPD0/RTCC/INT0/RD0 |
| 15 | PGEC1/VREF-/CVREF-/AN1/RPB1/RB1 | 47 | SOSCI/RPC13/RC13 |
| 16 | PGED1/VREF+/CVREF+/AN0/RPB0/PMA6/RB0 | 48 | SOSCO/RPC14/T1CK/RC14 |
| 17 | PGEC2/AN46/RPB6/RB6 | 49 | EMDIO/AEMDIO/RPD1/SCK1/RD1 |
| 18 | PGED2/AN47/RPB7/RB7 | 50 | ETXERR/AETXEN/RPD2/SDA3/RD2 |
| 19 | AVDD | 51 | AERXERR/ETXCLK/RPD3/SCL3/RD3 |
| 20 | AVss | 52 | SQICS0/RPD4/PMWR/RD4 |
| 21 | AN48/RPB8/PMA10/RB8 | 53 | SQICS1/RPD5/PMRD/RD5 |
| 22 | AN49/RPB9/PMA7/RB9 | 54 | VDD |
| 23 | TMS/CVREFOUT/AN5/RPB10/PMA13/RB10 | 55 | Vss |
| 24 | TDO/AN6/PMA12/RB11 | 56 | ERXD3/AETXD1/RPF0/RF0 |
| 25 | Vss | 57 | TRCLK/SQICLK/ERXD2/AETXD0/RPF1/RF1 |
| 26 | VDD | 58 | TRD0/SQID0/ERXD1/PMD0/RE0 |
| 27 | TCK/AN7/PMA11/RB12 | 59 | Vss |
| 28 | TDI/AN8/RB13 | 60 | VDD |
| 29 | AN9/RPB14/SCK3/PMA1/RB14 | 61 | TRD1/SQID1/ERXD0/PMD1/RE1 |
| 30 | AN10/EMDC/AEMDC/RPB15/OCFB/PMA0/RB15 | 62 | TRD2/SQID2/ERXDV/ECRSV/AECRSV/PMD2/RE2 |
| 31 | OSC1/CLKI/RC12 | 63 | TRD3/SQID3/ERXCLK/EREFCLK/RPE3/PMD3/RE3 |
| 32 | OSC2/CLKO/RC15 | 64 | AN18/ERXERR/PMD4/RE4 |

- Note**
- 1: The RPN pins can be used by remappable peripherals. See [Table 1](#) for the available peripherals and [Section 12.4 “Peripheral Pin Select \(PPS\)”](#) for restrictions.
 - 2: Every I/O port pin (RBx-RGx) can be used as a change notification pin (CNBx-CNGx). See [Section 12.0 “I/O Ports”](#) for more information.
 - 3: Shaded pins are 5V tolerant.
 - 4: The metal plane at the bottom of the device is not connected to any pins and is recommended to be connected to Vss externally.

PIC32MZ Embedded Connectivity with Floating Point Unit (EF) Family

TABLE 3: PIN NAMES FOR 100-PIN DEVICES

| 100-PIN TQFP (TOP VIEW) | | | |
|--|---|-------|--|
| <p>PIC32MZ0512EF(E/F/K)100 PIC32MZ1024EF(G/H/M)100 PIC32MZ1024EF(E/F/K)100 PIC32MZ2048EF(G/H/M)100</p>  | | | |
| Pin # | Full Pin Name | Pin # | Full Pin Name |
| 1 | AN23/AERXERR/RG15 | 36 | Vss |
| 2 | EBIA5/AN34/PMA5/RA5 | 37 | Vdd |
| 3 | EBID5/AN17/RPE5/PMD5/RE5 | 38 | TCK/EBIA19/AN29/RA1 |
| 4 | EBID6/AN16/PMD6/RE6 | 39 | TDI/EBIA18/AN30/RPF13/SCK5/RF13 |
| 5 | EBID7/AN15/PMD7/RE7 | 40 | TDO/EBIA17/AN31/RPF12/RF12 |
| 6 | EBIA6/AN22/RPC1/PMA6/RC1 | 41 | EBIA11/AN7/ERXD0/AECRS/PMA11/RB12 |
| 7 | EBIA12/AN21/RPC2/PMA12/RC2 | 42 | AN8/ERXD1/AECOL/RB13 |
| 8 | EBIWE/AN20/RPC3/PMWR/RC3 | 43 | EBIA1/AN9/ERXD2/AETXD3/RPB14/SCK3/PMA1/RB14 |
| 9 | EBIOE/AN19/PC4/PMRD/RC4 | 44 | EBIA0/AN10/ERXD3/AETXD2/RPB15/OCFB/PMA0/RB15 |
| 10 | AN14/C1IND/ECOL/RPG6/SCK2/RG6 | 45 | Vss |
| 11 | EBIA4/AN13/C1INC/ECRS/RPG7/SDA4/PMA4/RG7 | 46 | Vdd |
| 12 | EBIA3/AN12/C2IND/ERXDV/ECRSDV/AERXDV/ AECRSDV/RPG8/SCL4/PMA3/RG8 | 47 | AN32/AETXD0/RPD14/RD14 |
| 13 | Vss | 48 | AN33/AETXD1/RPD15/SCK6/RD15 |
| 14 | Vdd | 49 | OSC1/CLKI/RC12 |
| 15 | MCLR | 50 | OSC2/CLKO/RC15 |
| 16 | EBIA2/AN11/C2INC/ERXCLK/EREFCLK/AERXCLK/ AEREFCLK/RPG9/PMA2/RG9 | 51 | Vbus |
| 17 | TMS/EBIA16/AN24/RA0 | 52 | VUSB3v3 |
| 18 | AN25/AERXD0/RPE8/RE8 | 53 | Vss |
| 19 | AN26/AERXD1/RPE9/RE9 | 54 | D- |
| 20 | AN45/C1INA/RPB5/RB5 | 55 | D+ |
| 21 | AN4/C1INB/RB4 | 56 | RPF3/USBID/RF3 |
| 22 | AN3/C2INA/RPB3/RB3 | 57 | EBIRDY3/RPF2/SDA3/RF2 |
| 23 | AN2/C2INB/RPB2/RB2 | 58 | EBIRDY2/RPF8/SCL3/RF8 |
| 24 | PGEC1/AN1/RPB1/RB1 | 59 | EBICS0/SCL2/RA2 |
| 25 | PGED1/AN0/RPB0/RB0 | 60 | EBIRDY1/SDA2/RA3 |
| 26 | PGEC2/AN46/RPB6/RB6 | 61 | EBIA14/PMCS1/PMA14/RA4 |
| 27 | PGED2/AN47/RPB7/RB7 | 62 | Vdd |
| 28 | VREF-/CVREF-/AN27/AERXD2/RA9 | 63 | Vss |
| 29 | VREF+/CVREF+/AN28/AERXD3/RA10 | 64 | EBIA9/RPF4/SDA5/PMA9/RF4 |
| 30 | AVdd | 65 | EBIA8/RPF5/SCL5/PMA8/RF5 |
| 31 | AVss | 66 | AETXCLK/RPA14/SCL1/RA14 |
| 32 | EBIA10/AN48/RPB8/PMA10/RB8 | 67 | AETXEN/RPA15/SDA1/RA15 |
| 33 | EBIA7/AN49/RPB9/PMA7/RB9 | 68 | EBIA15/RPD9/PMCS2/PMA15/RD9 |
| 34 | EBIA13/CVREFOUT/AN5/RPB10/PMA13/RB10 | 69 | RPD10/SCK4/RD10 |
| 35 | AN6/ERXERR/AETXERR/RB11 | 70 | EMDC/AEMDC/RPD11/RD11 |

- Note**
- 1: The RPN pins can be used by remappable peripherals. See [Table 1](#) for the available peripherals and [Section 12.4 "Peripheral Pin Select \(PPS\)"](#) for restrictions.
 - 2: Every I/O port pin (RAX-RGX) can be used as a change notification pin (CNAX-CNGX). See [Section 12.0 "I/O Ports"](#) for more information.
 - 3: Shaded pins are 5V tolerant.

PIC32MZ Embedded Connectivity with Floating Point Unit (EF) Family

TABLE 3: PIN NAMES FOR 100-PIN DEVICES (CONTINUED)

100-PIN TQFP (TOP VIEW)

PIC32MZ0512EF(E/F/K)100
 PIC32MZ1024EF(G/H/M)100
 PIC32MZ1024EF(E/F/K)100
 PIC32MZ2048EF(G/H/M)100

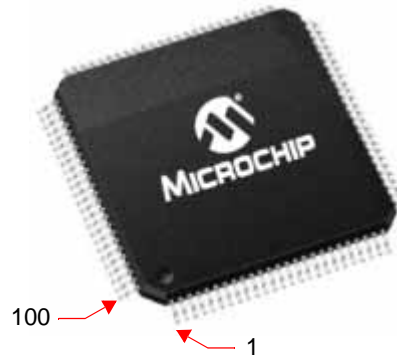

| Pin # | Full Pin Name | Pin # | Full Pin Name |
|-------|---------------------------------|-------|-----------------------------|
| 71 | EMDIO/AEMDIO/RPD0/RTCC/INT0/RD0 | 86 | EBID10/ETXD0/RPF1/PMD10/RF1 |
| 72 | SOSCI/RPC13/RC13 | 87 | EBID9/ETXERR/RPG1/PMD9/RG1 |
| 73 | SOSCO/RPC14/T1CK/RC14 | 88 | EBID8/RPG0/PMD8/RG0 |
| 74 | VDD | 89 | TRCLK/SQICLK/RA6 |
| 75 | VSS | 90 | TRD3/SQID3/RA7 |
| 76 | RPD1/SCK1/RD1 | 91 | EBID0/PMD0/RE0 |
| 77 | EBID14/ETXEN/RPD2/PMD14/RD2 | 92 | VSS |
| 78 | EBID15/ETXCLK/RPD3/PMD15/RD3 | 93 | VDD |
| 79 | EBID12/ETXD2/RPD12/PMD12/RD12 | 94 | EBID1/PMD1/RE1 |
| 80 | EBID13/ETXD3/PMD13/RD13 | 95 | TRD2/SQID2/RG14 |
| 81 | SQICS0/RPD4/RD4 | 96 | TRD1/SQID1/RG12 |
| 82 | SQICS1/RPD5/RD5 | 97 | TRD0/SQID0/RG13 |
| 83 | VDD | 98 | EBID2/PMD2/RE2 |
| 84 | VSS | 99 | EBID3/RPE3/PMD3/RE3 |
| 85 | EBID11/ETXD1/RPF0/PMD11/RF0 | 100 | EBID4/AN18/PMD4/RE4 |

- Note**
- 1: The RPN pins can be used by remappable peripherals. See [Table 1](#) for the available peripherals and [Section 12.4 "Peripheral Pin Select \(PPS\)"](#) for restrictions.
 - 2: Every I/O port pin (RAX-RGX) can be used as a change notification pin (CNAX-CNGX). See [Section 12.0 "I/O Ports"](#) for more information.
 - 3: Shaded pins are 5V tolerant.

PIC32MZ Embedded Connectivity with Floating Point Unit (EF) Family

TABLE 4: PIN NAMES FOR 124-PIN DEVICES

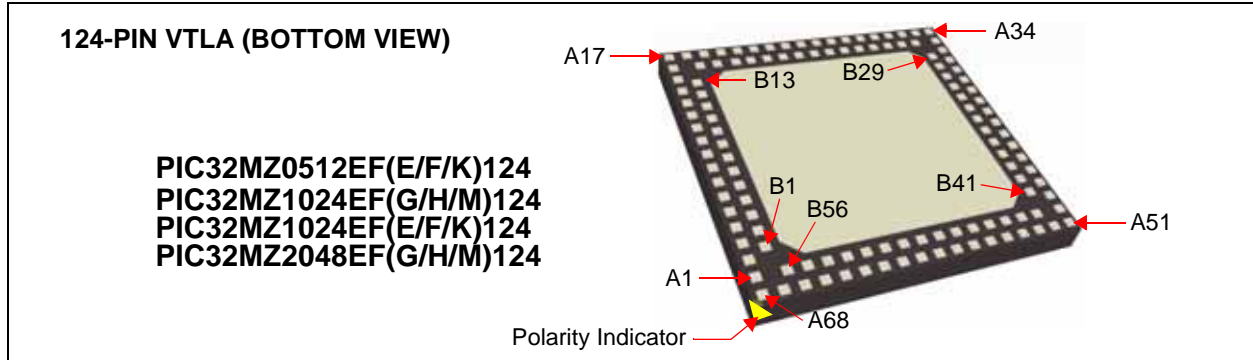

| Package Pin # | Full Pin Name | Package Pin # | Full Pin Name |
|---------------|-------------------------------------|---------------|--------------------------|
| A1 | No Connect | A35 | VBus |
| A2 | AN23/RG15 | A36 | VUSB3V3 |
| A3 | EBID5/AN17/RPE5/PMD5/RE5 | A37 | D- |
| A4 | EBID7/AN15/PMD7/RE7 | A38 | RPF3/USBID/RF3 |
| A5 | AN35/ETXD0/RJ8 | A39 | EBIRDY2/RPF8/SCL3/RF8 |
| A6 | EBIA12/AN21/RPC2/PMA12/RC2 | A40 | ERXD3/RH9 |
| A7 | EBIOE/AN19/RPC4/PMRD/RC4 | A41 | EBICS0/SCL2/RA2 |
| A8 | EBIA4/AN13/C1INC/RPG7/SDA4/PMA4/RG7 | A42 | EBIA14/PMCS1/PMA14/RA4 |
| A9 | Vss | A43 | Vss |
| A10 | MCLR | A44 | EBIA8/RPF5/SCL5/PMA8/RF5 |
| A11 | TMS/EBIA16/AN24/RA0 | A45 | RPA15/SDA1/RA15 |
| A12 | AN26/RPE9/RE9 | A46 | RPD10/SCK4/RD10 |
| A13 | AN4/C1INB/RB4 | A47 | ECRS/RH12 |
| A14 | AN3/C2INA/RPB3/RB3 | A48 | RPD0/RTCC/INT0/RD0 |
| A15 | VDD | A49 | SOSCO/RPC14/T1CK/RC14 |
| A16 | AN2/C2INB/RPB2/RB2 | A50 | VDD |
| A17 | PGEC1/AN1/RPB1/RB1 | A51 | Vss |
| A18 | PGED1/AN0/RPB0/RB0 | A52 | RPD1/SCK1/RD1 |
| A19 | PGED2/AN47/RPB7/RB7 | A53 | EBID15/RPD3/PMD15/RD3 |
| A20 | VREF+/CVREF+/AN28/RA10 | A54 | EBID13/PMD13/RD13 |
| A21 | AVss | A55 | EMDIO/RJ1 |
| A22 | AN39/ETXD3/RH1 | A56 | SQICS0/RPD4/RD4 |
| A23 | EBIA7/AN49/RPB9/PMA7/RB9 | A57 | ETXEN/RPD6/RD6 |
| A24 | AN6/RB11 | A58 | VDD |
| A25 | VDD | A59 | EBID11/RPF0/PMD11/RF0 |
| A26 | TDI/EBIA18/AN30/RPF13/SCK5/RF13 | A60 | EBID9/RPG1/PMD9/RG1 |
| A27 | EBIA11/AN7/PMA11/RB12 | A61 | TRCLK/SQICLK/RA6 |
| A28 | EBIA1/AN9/RPB14/SCK3/PMA1/RB14 | A62 | RJ4 |
| A29 | Vss | A63 | Vss |
| A30 | AN40/ERXERR/RH4 | A64 | EBID1/PMD1/RE1 |
| A31 | AN42/ERXD2/RH6 | A65 | TRD1/SQID1/RG12 |
| A32 | AN33/RPD15/SCK6/RD15 | A66 | EBID2/SQID2/PMD2/RE2 |
| A33 | OSC2/CLKO/RC15 | A67 | EBID4/AN18/PMD4/RE4 |
| A34 | No Connect | A68 | No Connect |

- Note**
- 1: The RPN pins can be used by remappable peripherals. See [Table 1](#) for the available peripherals and [Section 12.4 "Peripheral Pin Select \(PPS\)"](#) for restrictions.
 - 2: Every I/O port pin (RAX-RJx) can be used as a change notification pin (CNAX-CNJx). See [Section 12.0 "I/O Ports"](#) for more information.
 - 3: Shaded pins are 5V tolerant.
 - 4: The metal plane at the bottom of the device is not connected to any pins and is recommended to be connected to Vss externally.

PIC32MZ Embedded Connectivity with Floating Point Unit (EF) Family

TABLE 4: PIN NAMES FOR 124-PIN DEVICES (CONTINUED)

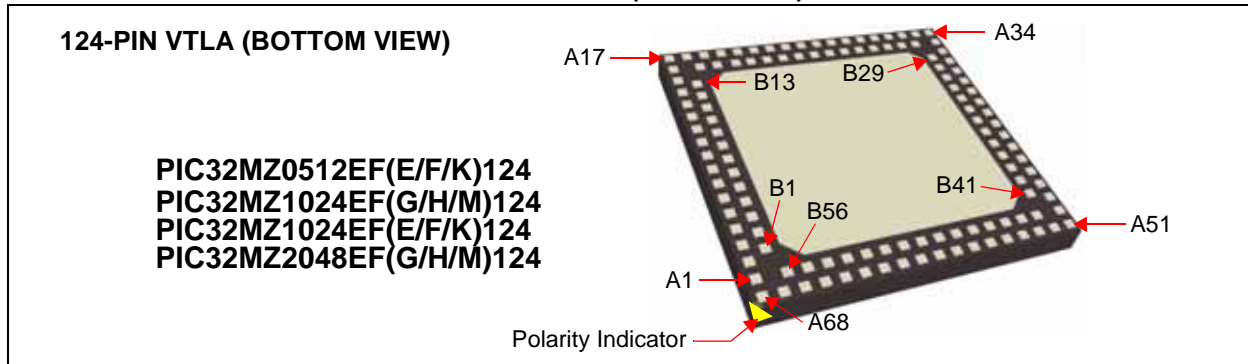

| Package Pin # | Full Pin Name | Package Pin # | Full Pin Name |
|---------------|--------------------------------------|---------------|-----------------------------|
| B1 | EBIA5/AN34/PMA5/RA5 | B29 | Vss |
| B2 | EBID6/AN16/PMD6/RE6 | B30 | D+ |
| B3 | EBIA6/AN22/RPC1/PMA6/RC1 | B31 | RPF2/SDA3/RF2 |
| B4 | AN36/ETXD1/RJ9 | B32 | ERXD0/RH8 |
| B5 | EBIWE/AN20/RPC3/PMWR/RC3 | B33 | ECOL/RH10 |
| B6 | AN14/C1IND/RPG6/SCK2/RG6 | B34 | EBIRDY1/SDA2/RA3 |
| B7 | EBIA3/AN12/C2IND/RPG8/SCL4/PMA3/RG8 | B35 | VDD |
| B8 | VDD | B36 | EBIA9/RPF4/SDA5/PMA9/RF4 |
| B9 | EBIA2/AN11/C2INC/RPG9/PMA2/RG9 | B37 | RPA14/SCL1/RA14 |
| B10 | AN25/RPE8/RE8 | B38 | EBIA15/RPD9/PMCS2/PMA15/RD9 |
| B11 | AN45/C1INA/RPB5/RB5 | B39 | EMDC/RPD11/RD11 |
| B12 | AN37/ERXCLK/EREFCLK/RJ11 | B40 | ERXDV/ECRSRV/RH13 |
| B13 | Vss | B41 | SOSCI/RPC13/RC13 |
| B14 | PGEC2/AN46/RPB6/RB6 | B42 | EBID14/RPD2/PMD14/RD2 |
| B15 | VREF-/CVREF-/AN27/RA9 | B43 | EBID12/RPD12/PMD12/RD12 |
| B16 | AVDD | B44 | ETXERR/RJ0 |
| B17 | AN38/ETXD2/RH0 | B45 | EBIRDY3/RJ2 |
| B18 | EBIA10/AN48/RPB8/PMA10/RB8 | B46 | SQICS1/RPD5/RD5 |
| B19 | EBIA13/CVREFOUT/AN5/RPB10/PMA13/RB10 | B47 | ETXCLK/RPD7/RD7 |
| B20 | Vss | B48 | Vss |
| B21 | TCK/EBIA19/AN29/RA1 | B49 | EBID10/RPF1/PMD10/RF1 |
| B22 | TDO/EBIA17/AN31/RPF12/RF12 | B50 | EBID8/RPG0/PMD8/RG0 |
| B23 | AN8/RB13 | B51 | TRD3/SQID3/RA7 |
| B24 | EBIA0/AN10/RPB15/OCFB/PMA0/RB15 | B52 | EBID0/PMD0/RE0 |
| B25 | VDD | B53 | VDD |
| B26 | AN41/ERXD1/RH5 | B54 | TRD2/SQID2/RG14 |
| B27 | AN32/AETXD0/RPD14/RD14 | B55 | TRD0/SQID0/RG13 |
| B28 | OSC1/CLKI/RC12 | B56 | EBID3/RPE3/PMD3/RE3 |

- Note 1:** The RPN pins can be used by remappable peripherals. See [Table 1](#) for the available peripherals and [Section 12.4 "Peripheral Pin Select \(PPS\)"](#) for restrictions.
- 2:** Every I/O port pin (RAX-RJx) can be used as a change notification pin (CNAX-CNJx). See [Section 12.0 "I/O Ports"](#) for more information.
- 3:** Shaded pins are 5V tolerant.
- 4:** The metal plane at the bottom of the device is not connected to any pins and is recommended to be connected to Vss externally.

PIC32MZ Embedded Connectivity with Floating Point Unit (EF) Family

TABLE 5: PIN NAMES FOR 144-PIN DEVICES

144-PIN LQFP AND TQFP (TOP VIEW)

PIC32MZ0512EF(E/F/K)144
 PIC32MZ1024EF(G/H/M)144
 PIC32MZ1024EF(E/F/K)144
 PIC32MZ2048EF(G/H/M)144

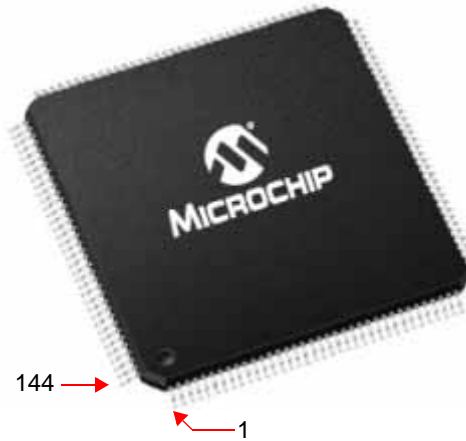

| Pin Number | Full Pin Name | Pin Number | Full Pin Name |
|------------|--------------------------------|------------|----------------------------|
| 1 | AN23/RG15 | 37 | PGEC2/AN46/RPB6/RB6 |
| 2 | EBIA5/AN34/PMA5/RA5 | 38 | PGED2/AN47/RPB7/RB7 |
| 3 | EBID5/AN17/RPE5/PMD5/RE5 | 39 | VREF-/CVREF-/AN27/RA9 |
| 4 | EBID6/AN16/PMD6/RE6 | 40 | VREF+/CVREF+/AN28/RA10 |
| 5 | EBID7/AN15/PMD7/RE7 | 41 | AVDD |
| 6 | EBIA6/AN22/RPC1/PMA6/RC1 | 42 | AVSS |
| 7 | AN35/ETXD0/RJ8 | 43 | AN38/ETXD2/RH0 |
| 8 | AN36/ETXD1/RJ9 | 44 | AN39/ETXD3/RH1 |
| 9 | EBIBS0/RJ12 | 45 | EBIRP/RH2 |
| 10 | EBIBS1/RJ10 | 46 | RH3 |
| 11 | EBIA12/AN21/RPC2/PMA12/RC2 | 47 | EBIA10/AN48/RPB8/PMA10/RB8 |
| 12 | EBIWE/AN20/RPC3/PMWR/RC3 | 48 | EBIA7/AN49/RPB9/PMA7/RB9 |
| 13 | EBIOE/AN19/RPC4/PMRD/RC4 | 49 | CVREFOUT/AN5/RPB10/RB10 |
| 14 | AN14/C1IND/RPG6/SCK2/RG6 | 50 | AN6/RB11 |
| 15 | AN13/C1INC/RPG7/SDA4/RG7 | 51 | EBIA1/PMA1/RK1 |
| 16 | AN12/C2IND/RPG8/SCL4/RG8 | 52 | EBIA3/PMA3/RK2 |
| 17 | VSS | 53 | EBIA17/RK3 |
| 18 | VDD | 54 | VSS |
| 19 | EBIA16/RK0 | 55 | VDD |
| 20 | MCLR | 56 | TCK/AN29/RA1 |
| 21 | EBIA2/AN11/C2INC/RPG9/PMA2/RG9 | 57 | TDI/AN30/RPF13/SCK5/RF13 |
| 22 | TMS/AN24/RA0 | 58 | TDO/AN31/RPF12/RF12 |
| 23 | AN25/RPE8/RE8 | 59 | AN7/RB12 |
| 24 | AN26/RPE9/RE9 | 60 | AN8/RB13 |
| 25 | AN45/C1INA/RPB5/RB5 | 61 | AN9/RPB14/SCK3/RB14 |
| 26 | AN4/C1INB/RB4 | 62 | AN10/RPB15/OCFB/RB15 |
| 27 | AN37/ERXCLK/EREFCLK/RJ11 | 63 | VSS |
| 28 | EBIA13/PMA13/RJ13 | 64 | VDD |
| 29 | EBIA11/PMA11/RJ14 | 65 | AN40/ERXERR/RH4 |
| 30 | EBIA0/PMA0/RJ15 | 66 | AN41/ERXD1/RH5 |
| 31 | AN3/C2INA/RPB3/RB3 | 67 | AN42/ERXD2/RH6 |
| 32 | VSS | 68 | EBIA4/PMA4/RH7 |
| 33 | VDD | 69 | AN32/RPD14/RD14 |
| 34 | AN2/C2INB/RPB2/RB2 | 70 | AN33/RPD15/SCK6/RD15 |
| 35 | PGEC1/AN1/RPB1/RB1 | 71 | OSC1/CLKI/RC12 |
| 36 | PGED1/AN0/RPB0/RB0 | 72 | OSC2/CLKO/RC15 |

- Note 1:** The RPN pins can be used by remappable peripherals. See [Table 1](#) for the available peripherals and [Section 12.4 “Peripheral Pin Select \(PPS\)”](#) for restrictions.
- 2:** Every I/O port pin (RAX-RKx) can be used as a change notification pin (CNAX-CNKx). See [Section 12.0 “I/O Ports”](#) for more information.
- 3:** Shaded pins are 5V tolerant.

PIC32MZ Embedded Connectivity with Floating Point Unit (EF) Family

TABLE 5: PIN NAMES FOR 144-PIN DEVICES (CONTINUED)

144-PIN LQFP AND TQFP (TOP VIEW)

PIC32MZ0512EF(E/F/K)144
PIC32MZ1024EF(G/H/M)144
PIC32MZ1024EF(E/F/K)144
PIC32MZ2048EF(G/H/M)144



| Pin Number | Full Pin Name | Pin Number | Full Pin Name |
|------------|-----------------------------|------------|-------------------------|
| 73 | VBUS | 109 | RPD1/SCK1/RD1 |
| 74 | VUSB3V3 | 110 | EBID14/RPD2/PMD14/RD2 |
| 75 | VSS | 111 | EBID15/RPD3/PMD15/RD3 |
| 76 | D- | 112 | EBID12/RPD12/PMD12/RD12 |
| 77 | D+ | 113 | EBID13/PMD13/RD13 |
| 78 | RPF3/USBID/RF3 | 114 | ETXERR/RJ0 |
| 79 | SDA3/RPF2/RF2 | 115 | EMDIO/RJ1 |
| 80 | SCL3/RPF8/RF8 | 116 | EBIRDY3/RJ2 |
| 81 | ERXD0/RH8 | 117 | EBIA22/RJ3 |
| 82 | ERXD3/RH9 | 118 | SQICS0/RPD4/RD4 |
| 83 | ECOL/RH10 | 119 | SQICS1/RPD5/RD5 |
| 84 | EBIRDY2/RH11 | 120 | ETXEN/RPD6/RD6 |
| 85 | SCL2/RA2 | 121 | ETXCLK/RPD7/RD7 |
| 86 | EBIRDY1/SDA2/RA3 | 122 | VDD |
| 87 | EBIA14/PMCS1/PMA14/RA4 | 123 | VSS |
| 88 | VDD | 124 | EBID11/RPF0/PMD11/RF0 |
| 89 | VSS | 125 | EBID10/RPF1/PMD10/RF1 |
| 90 | EBIA9/RPF4/SDA5/PMA9/RF4 | 126 | EBIA21/RK7 |
| 91 | EBIA8/RPF5/SCL5/PMA8/RF5 | 127 | EBID9/RPG1/PMD9/RG1 |
| 92 | EBIA18/RK4 | 128 | EBID8/RPG0/PMD8/RG0 |
| 93 | EBIA19/RK5 | 129 | TRCLK/SQICLK/RA6 |
| 94 | EBIA20/RK6 | 130 | TRD3/SQID3/RA7 |
| 95 | RPA14/SCL1/RA14 | 131 | EBICS0/RJ4 |
| 96 | RPA15/SDA1/RA15 | 132 | EBICS1/RJ5 |
| 97 | EBIA15/RPD9/PMCS2/PMA15/RD9 | 133 | EBICS2/RJ6 |
| 98 | RPD10/SCK4/RD10 | 134 | EBICS3/RJ7 |
| 99 | EMDC/RPD11/RD11 | 135 | EBID0/PMD0/RE0 |
| 100 | ECRS/RH12 | 136 | VSS |
| 101 | ERXDV/ECRSDV/RH13 | 137 | VDD |
| 102 | RH14 | 138 | EBID1/PMD1/RE1 |
| 103 | EBIA23/RH15 | 139 | TRD2/SQID2/RG14 |
| 104 | RPD0/RTCC/INT0/RD0 | 140 | TRD1/SQID1/RG12 |
| 105 | SOSCI/IPC13/RC13 | 141 | TRD0/SQID0/RG13 |
| 106 | SOSCO/IPC14/T1CK/RC14 | 142 | EBID2/PMD2/RE2 |
| 107 | VDD | 143 | EBID3/RPE3/PMD3/RE3 |
| 108 | VSS | 144 | EBID4/AN18/PMD4/RE4 |

- Note 1:** The RPN pins can be used by remappable peripherals. See [Table 1](#) for the available peripherals and [Section 12.4 “Peripheral Pin Select \(PPS\)”](#) for restrictions.
- Note 2:** Every I/O port pin (RAX-RKx) can be used as a change notification pin (CNAX-CNKx). See [Section 12.0 “I/O Ports”](#) for more information.
- Note 3:** Shaded pins are 5V tolerant.

PIC32MZ Embedded Connectivity with Floating Point Unit (EF) Family

Table of Contents

| | | |
|------|---|-----|
| 1.0 | Device Overview | 15 |
| 2.0 | Guidelines for Getting Started with 32-bit Microcontrollers | 37 |
| 3.0 | CPU | 43 |
| 4.0 | Memory Organization | 61 |
| 5.0 | Flash Program Memory | 99 |
| 6.0 | Resets | 109 |
| 7.0 | CPU Exceptions and Interrupt Controller | 115 |
| 8.0 | Oscillator Configuration | 155 |
| 9.0 | Prefetch Module | 171 |
| 10.0 | Direct Memory Access (DMA) Controller | 175 |
| 11.0 | Hi-Speed USB with On-The-Go (OTG) | 199 |
| 12.0 | I/O Ports | 249 |
| 13.0 | Timer1 | 285 |
| 14.0 | Timer2/3, Timer4/5, Timer6/7, and Timer8/9 | 289 |
| 15.0 | Deadman Timer (DMT) | 295 |
| 16.0 | Watchdog Timer (WDT) | 303 |
| 17.0 | Input Capture | 307 |
| 18.0 | Output Compare | 311 |
| 19.0 | Serial Peripheral Interface (SPI) and Inter-IC Sound (I ² S) | 317 |
| 20.0 | Serial Quad Interface (SQI) | 327 |
| 21.0 | Inter-Integrated Circuit™ (I ² C™) | 355 |
| 22.0 | Universal Asynchronous Receiver Transmitter (UART) | 363 |
| 23.0 | Parallel Master Port (PMP) | 371 |
| 24.0 | External Bus Interface (EBI) | 385 |
| 25.0 | Real-Time Clock and Calendar (RTCC) | 393 |
| 26.0 | Crypto Engine | 403 |
| 27.0 | Random Number Generator (RNG) | 423 |
| 28.0 | 12-bit High-Speed Successive Approximation Register (SAR) Analog-to-Digital Converter (ADC) | 429 |
| 29.0 | Controller Area Network (CAN) | 487 |
| 30.0 | Ethernet Controller | 525 |
| 31.0 | Comparator | 569 |
| 32.0 | Comparator Voltage Reference (CVREF) | 573 |
| 33.0 | Power-Saving Features | 577 |
| 34.0 | Special Features | 583 |
| 35.0 | Instruction Set | 605 |
| 36.0 | Development Support | 607 |
| 37.0 | Electrical Characteristics | 611 |
| 38.0 | AC and DC Characteristics Graphs | 663 |
| 39.0 | Packaging Information | 665 |
| | The Microchip Web Site | 717 |
| | Customer Change Notification Service | 717 |
| | Customer Support | 717 |
| | Product Identification System | 718 |

TO OUR VALUED CUSTOMERS

It is our intention to provide our valued customers with the best documentation possible to ensure successful use of your Microchip products. To this end, we will continue to improve our publications to better suit your needs. Our publications will be refined and enhanced as new volumes and updates are introduced.

If you have any questions or comments regarding this publication, please contact the Marketing Communications Department via E-mail at docerrors@microchip.com. We welcome your feedback.

Most Current Data Sheet

To obtain the most up-to-date version of this data sheet, please register at our Worldwide Web site at:

<http://www.microchip.com>

You can determine the version of a data sheet by examining its literature number found on the bottom outside corner of any page. The last character of the literature number is the version number, (e.g., DS30000000A is version A of document DS30000000).

Errata

An errata sheet, describing minor operational differences from the data sheet and recommended workarounds, may exist for current devices. As device/documentation issues become known to us, we will publish an errata sheet. The errata will specify the revision of silicon and revision of document to which it applies.

To determine if an errata sheet exists for a particular device, please check with one of the following:

- Microchip's Worldwide Web site; <http://www.microchip.com>
- Your local Microchip sales office (see last page)

When contacting a sales office, please specify which device, revision of silicon and data sheet (include literature number) you are using.

Customer Notification System

Register on our web site at www.microchip.com to receive the most current information on all of our products.

Referenced Sources

This device data sheet is based on the following individual sections of the *"PIC32 Family Reference Manual"*. These documents should be considered as the general reference for the operation of a particular module or device feature.

Note: To access the documents listed below, browse the documentation section of the Microchip website (www.microchip.com).

- **Section 1. "Introduction"** (DS60001127)
- **Section 7. "Resets"** (DS60001118)
- **Section 8. "Interrupt Controller"** (DS60001108)
- **Section 9. "Watchdog, Deadman, and Power-up Timers"** (DS60001114)
- **Section 10. "Power-Saving Features"** (DS60001130)
- **Section 12. "I/O Ports"** (DS60001120)
- **Section 13. "Parallel Master Port (PMP)"** (DS60001128)
- **Section 14. "Timers"** (DS60001105)
- **Section 15. "Input Capture"** (DS60001122)
- **Section 16. "Output Compare"** (DS60001111)
- **Section 19. "Comparator"** (DS60001110)
- **Section 20. "Comparator Voltage Reference (CVREF)"** (DS60001109)
- **Section 21. "Universal Asynchronous Receiver Transmitter (UART)"** (DS60001107)
- **Section 22. "12-bit High-Speed Successive Approximation Register (SAR) Analog-to-Digital Converter (ADC)"** (DS60001344)
- **Section 23. "Serial Peripheral Interface (SPI)"** (DS60001106)
- **Section 24. "Inter-Integrated Circuit™ (I²C™)"** (DS60001116)
- **Section 29. "Real-Time Clock and Calendar (RTCC)"** (DS60001125)
- **Section 31. "Direct Memory Access (DMA) Controller"** (DS60001117)
- **Section 32. "Configuration"** (DS60001124)
- **Section 33. "Programming and Diagnostics"** (DS60001129)
- **Section 34. "Controller Area Network (CAN)"** (DS60001154)
- **Section 35. "Ethernet Controller"** (DS60001155)
- **Section 41. "Prefetch Module for Devices with L1 CPU Cache"** (DS60001183)
- **Section 42. "Oscillators with Enhanced PLL"** (DS60001250)
- **Section 46. "Serial Quad Interface (SQI)"** (DS60001244)
- **Section 47. "External Bus Interface (EBI)"** (DS60001245)
- **Section 48. "Memory Organization and Permissions"** (DS60001214)
- **Section 49. "Crypto Engine (CE) and Random Number Generator (RNG)"** (DS60001246)
- **Section 50. "CPU for Devices with MIPS32® microAptiv™ and M-Class Cores"** (DS60001192)
- **Section 51. "Hi-Speed USB with On-The-Go (OTG)"** (DS60001326)
- **Section 52. "Flash Program Memory with Support for Live Update"** (DS60001193)

PIC32MZ Embedded Connectivity with Floating Point Unit (EF) Family

NOTES:

PIC32MZ Embedded Connectivity with Floating Point Unit (EF) Family

1.0 DEVICE OVERVIEW

Note: This data sheet summarizes the features of the PIC32MZ EF family of devices. It is not intended to be a comprehensive reference source. To complement the information in this data sheet, refer to the “PIC32 Family Reference Manual”, which is available from the Microchip web site (www.microchip.com/PIC32).

This data sheet contains device-specific information for PIC32MZ EF devices.

Figure 1-1 illustrates a general block diagram of the core and peripheral modules in the PIC32MZ EF family of devices.

Table 1-21 through Table 1-22 list the pinout I/O descriptions for the pins shown in the device pin tables (see Table 2 through Table 5).

FIGURE 1-1: PIC32MZ EF FAMILY BLOCK DIAGRAM

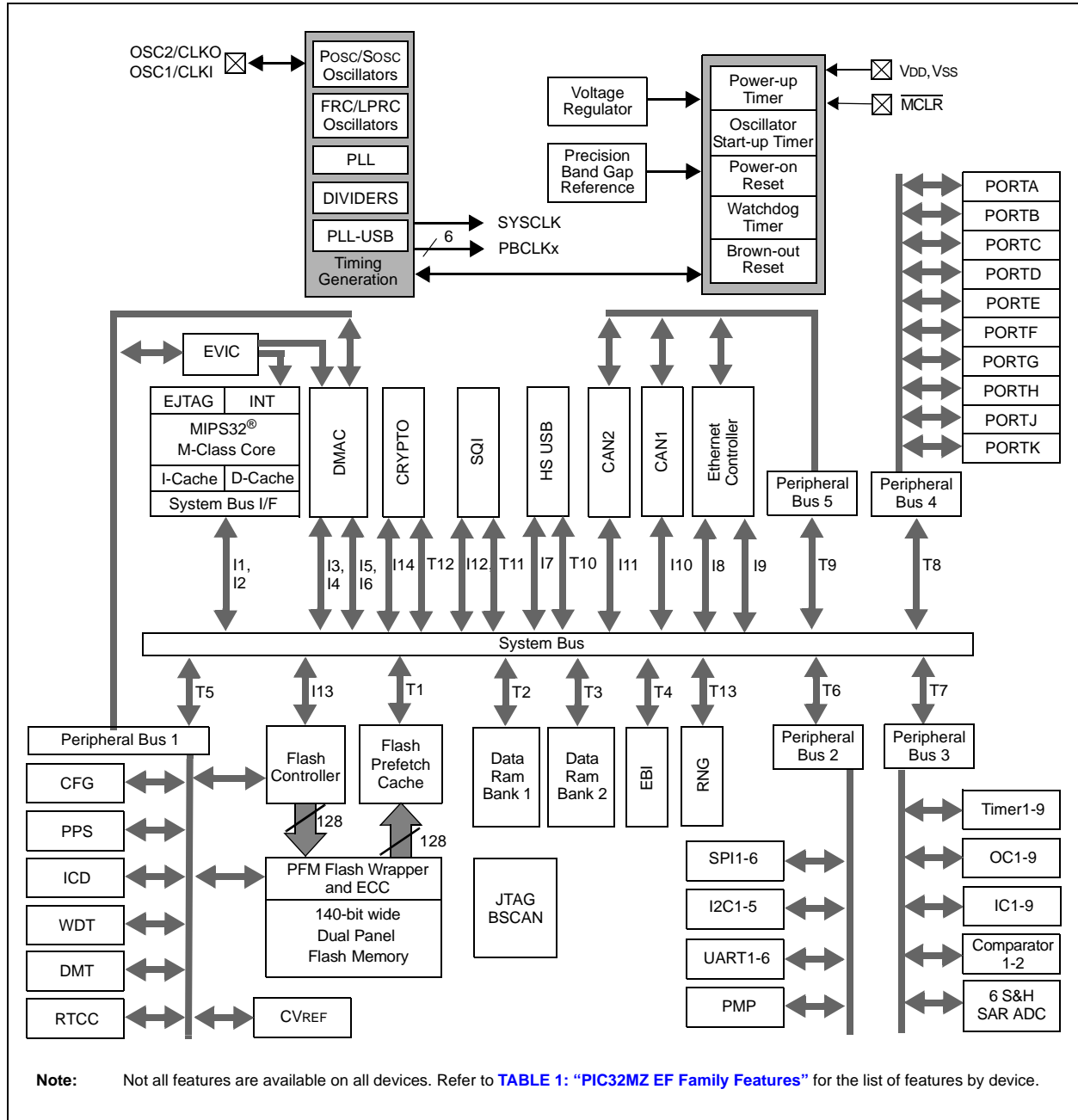

PIC32MZ Embedded Connectivity with Floating Point Unit (EF) Family

TABLE 1-1: ADC PINOUT I/O DESCRIPTIONS

| Pin Name | Pin Number | | | | Pin Type | Buffer Type | Description |
|----------|------------------|--------------|--------------|--------------------|----------|-------------|-----------------------|
| | 64-pin QFN/ TQFP | 100-pin TQFP | 124-pin VTLA | 144-pin TQFP/ LQFP | | | |
| AN0 | 16 | 25 | A18 | 36 | I | Analog | Analog Input Channels |
| AN1 | 15 | 24 | A17 | 35 | I | Analog | |
| AN2 | 14 | 23 | A16 | 34 | I | Analog | |
| AN3 | 13 | 22 | A14 | 31 | I | Analog | |
| AN4 | 12 | 21 | A13 | 26 | I | Analog | |
| AN5 | 23 | 34 | B19 | 49 | I | Analog | |
| AN6 | 24 | 35 | A24 | 50 | I | Analog | |
| AN7 | 27 | 41 | A27 | 59 | I | Analog | |
| AN8 | 28 | 42 | B23 | 60 | I | Analog | |
| AN9 | 29 | 43 | A28 | 61 | I | Analog | |
| AN10 | 30 | 44 | B24 | 62 | I | Analog | |
| AN11 | 10 | 16 | B9 | 21 | I | Analog | |
| AN12 | 6 | 12 | B7 | 16 | I | Analog | |
| AN13 | 5 | 11 | A8 | 15 | I | Analog | |
| AN14 | 4 | 10 | B6 | 14 | I | Analog | |
| AN15 | 3 | 5 | A4 | 5 | I | Analog | |
| AN16 | 2 | 4 | B2 | 4 | I | Analog | |
| AN17 | 1 | 3 | A3 | 3 | I | Analog | |
| AN18 | 64 | 100 | A67 | 144 | I | Analog | |
| AN19 | — | 9 | A7 | 13 | I | Analog | |
| AN20 | — | 8 | B5 | 12 | I | Analog | |
| AN21 | — | 7 | A6 | 11 | I | Analog | |
| AN22 | — | 6 | B3 | 6 | I | Analog | |
| AN23 | — | 1 | A2 | 1 | I | Analog | |
| AN24 | — | 17 | A11 | 22 | I | Analog | |
| AN25 | — | 18 | B10 | 23 | I | Analog | |
| AN26 | — | 19 | A12 | 24 | I | Analog | |
| AN27 | — | 28 | B15 | 39 | I | Analog | |
| AN28 | — | 29 | A20 | 40 | I | Analog | |
| AN29 | — | 38 | B21 | 56 | I | Analog | |
| AN30 | — | 39 | A26 | 57 | I | Analog | |
| AN31 | — | 40 | B22 | 58 | I | Analog | |
| AN32 | — | 47 | B27 | 69 | I | Analog | |
| AN33 | — | 48 | A32 | 70 | I | Analog | |
| AN34 | — | 2 | B1 | 2 | I | Analog | |
| AN35 | — | — | A5 | 7 | I | Analog | |

Legend: CMOS = CMOS-compatible input or output Analog = Analog input P = Power
 ST = Schmitt Trigger input with CMOS levels O = Output I = Input
 TTL = Transistor-transistor Logic input buffer PPS = Peripheral Pin Select

PIC32MZ Embedded Connectivity with Floating Point Unit (EF) Family

TABLE 1-1: ADC PINOUT I/O DESCRIPTIONS (CONTINUED)

| Pin Name | Pin Number | | | | Pin Type | Buffer Type | Description |
|----------|-----------------|--------------|--------------|-------------------|----------|-------------|-----------------------|
| | 64-pin QFN/TQFP | 100-pin TQFP | 124-pin VTLA | 144-pin TQFP/LQFP | | | |
| AN36 | — | — | B4 | 8 | I | Analog | Analog Input Channels |
| AN37 | — | — | B12 | 27 | I | Analog | |
| AN38 | — | — | B17 | 43 | I | Analog | |
| AN39 | — | — | A22 | 44 | I | Analog | |
| AN40 | — | — | A30 | 65 | I | Analog | |
| AN41 | — | — | B26 | 66 | I | Analog | |
| AN42 | — | — | A31 | 67 | I | Analog | |
| AN45 | 11 | 20 | B11 | 25 | I | Analog | |
| AN46 | 17 | 26 | B14 | 37 | I | Analog | |
| AN47 | 18 | 27 | A19 | 38 | I | Analog | |
| AN48 | 21 | 32 | B18 | 47 | I | Analog | |
| AN49 | 22 | 33 | A23 | 48 | I | Analog | |

Legend: CMOS = CMOS-compatible input or output
 ST = Schmitt Trigger input with CMOS levels
 TTL = Transistor-transistor Logic input buffer
 Analog = Analog input
 O = Output
 PPS = Peripheral Pin Select
 P = Power
 I = Input

PIC32MZ Embedded Connectivity with Floating Point Unit (EF) Family

TABLE 1-2: OSCILLATOR PINOUT I/O DESCRIPTIONS

| Pin Name | Pin Number | | | | Pin Type | Buffer Type | Description |
|----------|-----------------|--------------|--------------|-------------------|----------|-------------|--|
| | 64-pin QFN/TQFP | 100-pin TQFP | 124-pin VTLA | 144-pin TQFP/LQFP | | | |
| CLKI | 31 | 49 | B28 | 71 | I | ST/CMOS | External clock source input. Always associated with OSC1 pin function. |
| CLKO | 32 | 50 | A33 | 72 | O | — | Oscillator crystal output. Connects to crystal or resonator in Crystal Oscillator mode. Optionally functions as CLKO in RC and EC modes. Always associated with OSC2 pin function. |
| OSC1 | 31 | 49 | B28 | 71 | I | ST/CMOS | Oscillator crystal input. ST buffer when configured in RC mode; CMOS otherwise. |
| OSC2 | 32 | 50 | A33 | 72 | O | — | Oscillator crystal output. Connects to crystal or resonator in Crystal Oscillator mode. Optionally functions as CLKO in RC and EC modes. |
| SOSCI | 47 | 72 | B41 | 105 | I | ST/CMOS | 32.768 kHz low-power oscillator crystal input; CMOS otherwise. |
| SOSCO | 48 | 73 | A49 | 106 | O | — | 32.768 low-power oscillator crystal output. |
| REFCLKI1 | PPS | PPS | PPS | PPS | I | — | Reference Clock Generator Inputs 1-4 |
| REFCLKI3 | PPS | PPS | PPS | PPS | I | — | |
| REFCLKI4 | PPS | PPS | PPS | PPS | I | — | |
| REFCLKO1 | PPS | PPS | PPS | PPS | O | — | Reference Clock Generator Outputs 1-4 |
| REFCLKO3 | PPS | PPS | PPS | PPS | O | — | |
| REFCLKO4 | PPS | PPS | PPS | PPS | O | — | |

Legend: CMOS = CMOS-compatible input or output
 ST = Schmitt Trigger input with CMOS levels
 TTL = Transistor-transistor Logic input buffer
 Analog = Analog input
 O = Output
 PPS = Peripheral Pin Select
 P = Power
 I = Input

TABLE 1-3: IC1 THROUGH IC9 PINOUT I/O DESCRIPTIONS

| Pin Name | Pin Number | | | | Pin Type | Buffer Type | Description |
|----------------------|-----------------|--------------|--------------|-------------------|----------|-------------|--------------------------|
| | 64-pin QFN/TQFP | 100-pin TQFP | 124-pin VTLA | 144-pin TQFP/LQFP | | | |
| Input Capture | | | | | | | |
| IC1 | PPS | PPS | PPS | PPS | I | ST | Input Capture Inputs 1-9 |
| IC2 | PPS | PPS | PPS | PPS | I | ST | |
| IC3 | PPS | PPS | PPS | PPS | I | ST | |
| IC4 | PPS | PPS | PPS | PPS | I | ST | |
| IC5 | PPS | PPS | PPS | PPS | I | ST | |
| IC6 | PPS | PPS | PPS | PPS | I | ST | |
| IC7 | PPS | PPS | PPS | PPS | I | ST | |
| IC8 | PPS | PPS | PPS | PPS | I | ST | |
| IC9 | PPS | PPS | PPS | PPS | I | ST | |

Legend: CMOS = CMOS-compatible input or output
 ST = Schmitt Trigger input with CMOS levels
 TTL = Transistor-transistor Logic input buffer
 Analog = Analog input
 O = Output
 PPS = Peripheral Pin Select
 P = Power
 I = Input

PIC32MZ Embedded Connectivity with Floating Point Unit (EF) Family

TABLE 1-4: OC1 THROUGH OC9 PINOUT I/O DESCRIPTIONS

| Pin Name | Pin Number | | | | Pin Type | Buffer Type | Description |
|-----------------------|-----------------|--------------|--------------|-------------------|----------|-------------|------------------------------|
| | 64-pin QFN/TQFP | 100-pin TQFP | 124-pin VTLA | 144-pin TQFP/LQFP | | | |
| Output Compare | | | | | | | |
| OC1 | PPS | PPS | PPS | PPS | O | — | Output Compare Outputs 1-9 |
| OC2 | PPS | PPS | PPS | PPS | O | — | |
| OC3 | PPS | PPS | PPS | PPS | O | — | |
| OC4 | PPS | PPS | PPS | PPS | O | — | |
| OC5 | PPS | PPS | PPS | PPS | O | — | |
| OC6 | PPS | PPS | PPS | PPS | O | — | |
| OC7 | PPS | PPS | PPS | PPS | O | — | |
| OC8 | PPS | PPS | PPS | PPS | O | — | |
| OC9 | PPS | PPS | PPS | PPS | O | — | |
| OCFA | PPS | PPS | PPS | PPS | I | ST | Output Compare Fault A Input |
| OCFB | 30 | 44 | B24 | 62 | I | ST | Output Compare Fault B Input |

Legend: CMOS = CMOS-compatible input or output Analog = Analog input P = Power
 ST = Schmitt Trigger input with CMOS levels O = Output I = Input
 TTL = Transistor-transistor Logic input buffer PPS = Peripheral Pin Select

TABLE 1-5: EXTERNAL INTERRUPTS PINOUT I/O DESCRIPTIONS

| Pin Name | Pin Number | | | | Pin Type | Buffer Type | Description |
|----------------------------|-----------------|--------------|--------------|-------------------|----------|-------------|----------------------|
| | 64-pin QFN/TQFP | 100-pin TQFP | 124-pin VTLA | 144-pin TQFP/LQFP | | | |
| External Interrupts | | | | | | | |
| INT0 | 46 | 71 | A48 | 104 | I | ST | External Interrupt 0 |
| INT1 | PPS | PPS | PPS | PPS | I | ST | External Interrupt 1 |
| INT2 | PPS | PPS | PPS | PPS | I | ST | External Interrupt 2 |
| INT3 | PPS | PPS | PPS | PPS | I | ST | External Interrupt 3 |
| INT4 | PPS | PPS | PPS | PPS | I | ST | External Interrupt 4 |

Legend: CMOS = CMOS-compatible input or output Analog = Analog input P = Power
 ST = Schmitt Trigger input with CMOS levels O = Output I = Input
 TTL = Transistor-transistor Logic input buffer PPS = Peripheral Pin Select

PIC32MZ Embedded Connectivity with Floating Point Unit (EF) Family

TABLE 1-6: PORTA THROUGH PORTK PINOUT I/O DESCRIPTIONS

| Pin Name | Pin Number | | | | Pin Type | Buffer Type | Description |
|--------------|-----------------|--------------|--------------|-------------------|----------|-------------|-----------------------------------|
| | 64-pin QFN/TQFP | 100-pin TQFP | 124-pin VTLA | 144-pin TQFP/LQFP | | | |
| PORTA | | | | | | | |
| RA0 | — | 17 | A11 | 22 | I/O | ST | PORTA is a bidirectional I/O port |
| RA1 | — | 38 | B21 | 56 | I/O | ST | |
| RA2 | — | 59 | A41 | 85 | I/O | ST | |
| RA3 | — | 60 | B34 | 86 | I/O | ST | |
| RA4 | — | 61 | A42 | 87 | I/O | ST | |
| RA5 | — | 2 | B1 | 2 | I/O | ST | |
| RA6 | — | 89 | A61 | 129 | I/O | ST | |
| RA7 | — | 90 | B51 | 130 | I/O | ST | |
| RA9 | — | 28 | B15 | 39 | I/O | ST | |
| RA10 | — | 29 | A20 | 40 | I/O | ST | |
| RA14 | — | 66 | B37 | 95 | I/O | ST | |
| RA15 | — | 67 | A45 | 96 | I/O | ST | |
| PORTB | | | | | | | |
| RB0 | 16 | 25 | A18 | 36 | I/O | ST | PORTB is a bidirectional I/O port |
| RB1 | 15 | 24 | A17 | 35 | I/O | ST | |
| RB2 | 14 | 23 | A16 | 34 | I/O | ST | |
| RB3 | 13 | 22 | A14 | 31 | I/O | ST | |
| RB4 | 12 | 21 | A13 | 26 | I/O | ST | |
| RB5 | 11 | 20 | B11 | 25 | I/O | ST | |
| RB6 | 17 | 26 | B14 | 37 | I/O | ST | |
| RB7 | 18 | 27 | A19 | 38 | I/O | ST | |
| RB8 | 21 | 32 | B18 | 47 | I/O | ST | |
| RB9 | 22 | 33 | A23 | 48 | I/O | ST | |
| RB10 | 23 | 34 | B19 | 49 | I/O | ST | |
| RB11 | 24 | 35 | A24 | 50 | I/O | ST | |
| RB12 | 27 | 41 | A27 | 59 | I/O | ST | |
| RB13 | 28 | 42 | B23 | 60 | I/O | ST | |
| RB14 | 29 | 43 | A28 | 61 | I/O | ST | |
| RB15 | 30 | 44 | B24 | 62 | I/O | ST | |
| PORTC | | | | | | | |
| RC1 | — | 6 | B3 | 6 | I/O | ST | PORTC is a bidirectional I/O port |
| RC2 | — | 7 | A6 | 11 | I/O | ST | |
| RC3 | — | 8 | B5 | 12 | I/O | ST | |
| RC4 | — | 9 | A7 | 13 | I/O | ST | |
| RC12 | 31 | 49 | B28 | 71 | I/O | ST | |
| RC13 | 47 | 72 | B41 | 105 | I/O | ST | |
| RC14 | 48 | 73 | A49 | 106 | I/O | ST | |
| RC15 | 32 | 50 | A33 | 72 | I/O | ST | |

Legend: CMOS = CMOS-compatible input or output Analog = Analog input P = Power
 ST = Schmitt Trigger input with CMOS levels O = Output I = Input
 TTL = Transistor-transistor Logic input buffer PPS = Peripheral Pin Select

PIC32MZ Embedded Connectivity with Floating Point Unit (EF) Family

TABLE 1-6: PORTA THROUGH PORTK PINOUT I/O DESCRIPTIONS (CONTINUED)

| Pin Name | Pin Number | | | | Pin Type | Buffer Type | Description |
|--------------|-----------------|--------------|--------------|-------------------|----------|-------------|-----------------------------------|
| | 64-pin QFN/TQFP | 100-pin TQFP | 124-pin VTLA | 144-pin TQFP/LQFP | | | |
| PORTD | | | | | | | |
| RD0 | 46 | 71 | A48 | 104 | I/O | ST | PORTD is a bidirectional I/O port |
| RD1 | 49 | 76 | A52 | 109 | I/O | ST | |
| RD2 | 50 | 77 | B42 | 110 | I/O | ST | |
| RD3 | 51 | 78 | A53 | 111 | I/O | ST | |
| RD4 | 52 | 81 | A56 | 118 | I/O | ST | |
| RD5 | 53 | 82 | B46 | 119 | I/O | ST | |
| RD6 | — | — | A57 | 120 | I/O | ST | |
| RD7 | — | — | B47 | 121 | I/O | ST | |
| RD9 | 43 | 68 | B38 | 97 | I/O | ST | |
| RD10 | 44 | 69 | A46 | 98 | I/O | ST | |
| RD11 | 45 | 70 | B39 | 99 | I/O | ST | |
| RD12 | — | 79 | B43 | 112 | I/O | ST | |
| RD13 | — | 80 | A54 | 113 | I/O | ST | |
| RD14 | — | 47 | B27 | 69 | I/O | ST | |
| RD15 | — | 48 | A32 | 70 | I/O | ST | |
| PORTE | | | | | | | |
| RE0 | 58 | 91 | B52 | 135 | I/O | ST | PORTE is a bidirectional I/O port |
| RE1 | 61 | 94 | A64 | 138 | I/O | ST | |
| RE2 | 62 | 98 | A66 | 142 | I/O | ST | |
| RE3 | 63 | 99 | B56 | 143 | I/O | ST | |
| RE4 | 64 | 100 | A67 | 144 | I/O | ST | |
| RE5 | 1 | 3 | A3 | 3 | I/O | ST | |
| RE6 | 2 | 4 | B2 | 4 | I/O | ST | |
| RE7 | 3 | 5 | A4 | 5 | I/O | ST | |
| RE8 | — | 18 | B10 | 23 | I/O | ST | |
| RE9 | — | 19 | A12 | 24 | I/O | ST | |
| PORTF | | | | | | | |
| RF0 | 56 | 85 | A59 | 124 | I/O | ST | PORTF is a bidirectional I/O port |
| RF1 | 57 | 86 | B49 | 125 | I/O | ST | |
| RF2 | — | 57 | B31 | 79 | I/O | ST | |
| RF3 | 38 | 56 | A38 | 78 | I/O | ST | |
| RF4 | 41 | 64 | B36 | 90 | I/O | ST | |
| RF5 | 42 | 65 | A44 | 91 | I/O | ST | |
| RF8 | — | 58 | A39 | 80 | I/O | ST | |
| RF12 | — | 40 | B22 | 58 | I/O | ST | |
| RF13 | — | 39 | A26 | 57 | I/O | ST | |

Legend: CMOS = CMOS-compatible input or output Analog = Analog input P = Power
 ST = Schmitt Trigger input with CMOS levels O = Output I = Input
 TTL = Transistor-transistor Logic input buffer PPS = Peripheral Pin Select

PIC32MZ Embedded Connectivity with Floating Point Unit (EF) Family

TABLE 1-6: PORTA THROUGH PORTK PINOUT I/O DESCRIPTIONS (CONTINUED)

| Pin Name | Pin Number | | | | Pin Type | Buffer Type | Description |
|--------------|-----------------|--------------|--------------|-------------------|----------|-------------|-----------------------------------|
| | 64-pin QFN/TQFP | 100-pin TQFP | 124-pin VTLA | 144-pin TQFP/LQFP | | | |
| PORTG | | | | | | | |
| RG0 | — | 88 | B50 | 128 | I/O | ST | PORTG is a bidirectional I/O port |
| RG1 | — | 87 | A60 | 127 | I/O | ST | |
| RG6 | 4 | 10 | B6 | 14 | I/O | ST | |
| RG7 | 5 | 11 | A8 | 15 | I/O | ST | |
| RG8 | 6 | 12 | B7 | 16 | I/O | ST | |
| RG9 | 10 | 16 | B9 | 21 | I/O | ST | |
| RG12 | — | 96 | A65 | 140 | I/O | ST | |
| RG13 | — | 97 | B55 | 141 | I/O | ST | |
| RG14 | — | 95 | B54 | 139 | I/O | ST | |
| RG15 | — | 1 | A2 | 1 | I/O | ST | |
| PORTH | | | | | | | |
| RH0 | — | — | B17 | 43 | I/O | ST | PORTH is a bidirectional I/O port |
| RH1 | — | — | A22 | 44 | I/O | ST | |
| RH2 | — | — | — | 45 | I/O | ST | |
| RH3 | — | — | — | 46 | I/O | ST | |
| RH4 | — | — | A30 | 65 | I/O | ST | |
| RH5 | — | — | B26 | 66 | I/O | ST | |
| RH6 | — | — | A31 | 67 | I/O | ST | |
| RH7 | — | — | — | 68 | I/O | ST | |
| RH8 | — | — | B32 | 81 | I/O | ST | |
| RH9 | — | — | A40 | 82 | I/O | ST | |
| RH10 | — | — | B33 | 83 | I/O | ST | |
| RH11 | — | — | — | 84 | I/O | ST | |
| RH12 | — | — | A47 | 100 | I/O | ST | |
| RH13 | — | — | B40 | 101 | I/O | ST | |
| RH14 | — | — | — | 102 | I/O | ST | |
| RH15 | — | — | — | 103 | I/O | ST | |
| PORTJ | | | | | | | |
| RJ0 | — | — | B44 | 114 | I/O | ST | PORTJ is a bidirectional I/O port |
| RJ1 | — | — | A55 | 115 | I/O | ST | |
| RJ2 | — | — | B45 | 116 | I/O | ST | |
| RJ3 | — | — | — | 117 | I/O | ST | |
| RJ4 | — | — | A62 | 131 | I/O | ST | |
| RJ5 | — | — | — | 132 | I/O | ST | |
| RJ6 | — | — | — | 133 | I/O | ST | |
| RJ7 | — | — | — | 134 | I/O | ST | |
| RJ8 | — | — | A5 | 7 | I/O | ST | |
| RJ9 | — | — | B4 | 8 | I/O | ST | |
| RJ10 | — | — | — | 10 | I/O | ST | |
| RJ11 | — | — | B12 | 27 | I/O | ST | |
| RJ12 | — | — | — | 9 | I/O | ST | |
| RJ13 | — | — | — | 28 | I/O | ST | |
| RJ14 | — | — | — | 29 | I/O | ST | |
| RJ15 | — | — | — | 30 | I/O | ST | |

Legend: CMOS = CMOS-compatible input or output Analog = Analog input P = Power
 ST = Schmitt Trigger input with CMOS levels O = Output I = Input
 TTL = Transistor-transistor Logic input buffer PPS = Peripheral Pin Select

PIC32MZ Embedded Connectivity with Floating Point Unit (EF) Family

TABLE 1-6: PORTA THROUGH PORTK PINOUT I/O DESCRIPTIONS (CONTINUED)

| Pin Name | Pin Number | | | | Pin Type | Buffer Type | Description |
|--------------|-----------------|--------------|--------------|-------------------|----------|-------------|-----------------------------------|
| | 64-pin QFN/TQFP | 100-pin TQFP | 124-pin VTLA | 144-pin TQFP/LQFP | | | |
| PORTK | | | | | | | |
| RK0 | — | — | — | 19 | I/O | ST | PORTK is a bidirectional I/O port |
| RK1 | — | — | — | 51 | I/O | ST | |
| RK2 | — | — | — | 52 | I/O | ST | |
| RK3 | — | — | — | 53 | I/O | ST | |
| RK4 | — | — | — | 92 | I/O | ST | |
| RK5 | — | — | — | 93 | I/O | ST | |
| RK6 | — | — | — | 94 | I/O | ST | |
| RK7 | — | — | — | 126 | I/O | ST | |

Legend: CMOS = CMOS-compatible input or output Analog = Analog input P = Power
 ST = Schmitt Trigger input with CMOS levels O = Output I = Input
 TTL = Transistor-transistor Logic input buffer PPS = Peripheral Pin Select

PIC32MZ Embedded Connectivity with Floating Point Unit (EF) Family

TABLE 1-7: TIMER1 THROUGH TIMER9 AND RTCC PINOUT I/O DESCRIPTIONS

| Pin Name | Pin Number | | | | Pin Type | Buffer Type | Description |
|------------------------------|-----------------|--------------|--------------|-------------------|----------|-------------|--------------------------------------|
| | 64-pin QFN/TQFP | 100-pin TQFP | 124-pin VTLA | 144-pin TQFP/LQFP | | | |
| Timer1 through Timer9 | | | | | | | |
| T1CK | 48 | 73 | A49 | 106 | I | ST | Timer1 External Clock Input |
| T2CK | PPS | PPS | PPS | PPS | I | ST | Timer2 External Clock Input |
| T3CK | PPS | PPS | PPS | PPS | I | ST | Timer3 External Clock Input |
| T4CK | PPS | PPS | PPS | PPS | I | ST | Timer4 External Clock Input |
| T5CK | PPS | PPS | PPS | PPS | I | ST | Timer5 External Clock Input |
| T6CK | PPS | PPS | PPS | PPS | I | ST | Timer6 External Clock Input |
| T7CK | PPS | PPS | PPS | PPS | I | ST | Timer7 External Clock Input |
| T8CK | PPS | PPS | PPS | PPS | I | ST | Timer8 External Clock Input |
| T9CK | PPS | PPS | PPS | PPS | I | ST | Timer9 External Clock Input |
| Real-Time Clock and Calendar | | | | | | | |
| RTCC | 46 | 71 | A48 | 104 | O | — | Real-Time Clock Alarm/Seconds Output |

Legend: CMOS = CMOS-compatible input or output
 ST = Schmitt Trigger input with CMOS levels
 TTL = Transistor-transistor Logic input buffer
 Analog = Analog input
 O = Output
 PPS = Peripheral Pin Select
 P = Power
 I = Input

PIC32MZ Embedded Connectivity with Floating Point Unit (EF) Family

TABLE 1-8: UART1 THROUGH UART6 PINOUT I/O DESCRIPTIONS

| Pin Name | Pin Number | | | | Pin Type | Buffer Type | Description |
|--|-----------------|--------------|--------------|-------------------|----------|-------------|---------------------|
| | 64-pin QFN/TQFP | 100-pin TQFP | 124-pin VTLA | 144-pin TQFP/LQFP | | | |
| Universal Asynchronous Receiver Transmitter 1 | | | | | | | |
| U1RX | PPS | PPS | PPS | PPS | I | ST | UART1 Receive |
| U1TX | PPS | PPS | PPS | PPS | O | — | UART1 Transmit |
| U1CTS | PPS | PPS | PPS | PPS | I | ST | UART1 Clear to Send |
| U1RTS | PPS | PPS | PPS | PPS | O | — | UART1 Ready to Send |
| Universal Asynchronous Receiver Transmitter 2 | | | | | | | |
| U2RX | PPS | PPS | PPS | PPS | I | ST | UART2 Receive |
| U2TX | PPS | PPS | PPS | PPS | O | — | UART2 Transmit |
| U2CTS | PPS | PPS | PPS | PPS | I | ST | UART2 Clear To Send |
| U2RTS | PPS | PPS | PPS | PPS | O | — | UART2 Ready To Send |
| Universal Asynchronous Receiver Transmitter 3 | | | | | | | |
| U3RX | PPS | PPS | PPS | PPS | I | ST | UART3 Receive |
| U3TX | PPS | PPS | PPS | PPS | O | — | UART3 Transmit |
| U3CTS | PPS | PPS | PPS | PPS | I | ST | UART3 Clear to Send |
| U3RTS | PPS | PPS | PPS | PPS | O | — | UART3 Ready to Send |
| Universal Asynchronous Receiver Transmitter 4 | | | | | | | |
| U4RX | PPS | PPS | PPS | PPS | I | ST | UART4 Receive |
| U4TX | PPS | PPS | PPS | PPS | O | — | UART4 Transmit |
| U4CTS | PPS | PPS | PPS | PPS | I | ST | UART4 Clear to Send |
| U4RTS | PPS | PPS | PPS | PPS | O | — | UART4 Ready to Send |
| Universal Asynchronous Receiver Transmitter 5 | | | | | | | |
| U5RX | PPS | PPS | PPS | PPS | I | ST | UART5 Receive |
| U5TX | PPS | PPS | PPS | PPS | O | — | UART5 Transmit |
| U5CTS | PPS | PPS | PPS | PPS | I | ST | UART5 Clear to Send |
| U5RTS | PPS | PPS | PPS | PPS | O | — | UART5 Ready to Send |
| Universal Asynchronous Receiver Transmitter 6 | | | | | | | |
| U6RX | PPS | PPS | PPS | PPS | I | ST | UART6 Receive |
| U6TX | PPS | PPS | PPS | PPS | O | — | UART6 Transmit |
| U6CTS | PPS | PPS | PPS | PPS | I | ST | UART6 Clear to Send |
| U6RTS | PPS | PPS | PPS | PPS | O | — | UART6 Ready to Send |

Legend: CMOS = CMOS-compatible input or output Analog = Analog input P = Power
 ST = Schmitt Trigger input with CMOS levels O = Output I = Input
 TTL = Transistor-transistor Logic input buffer PPS = Peripheral Pin Select

PIC32MZ Embedded Connectivity with Floating Point Unit (EF) Family

TABLE 1-9: SPI1 THROUGH SPI 6 PINOUT I/O DESCRIPTIONS

| Pin Name | Pin Number | | | | Pin Type | Buffer Type | Description |
|--------------------------------------|-----------------|--------------|--------------|-------------------|----------|-------------|---|
| | 64-pin QFN/TQFP | 100-pin TQFP | 124-pin VTLA | 144-pin TQFP/LQFP | | | |
| Serial Peripheral Interface 1 | | | | | | | |
| SCK1 | 49 | 76 | A52 | 109 | I/O | ST | SPI1 Synchronous Serial Clock Input/Output |
| SDI1 | PPS | PPS | PPS | PPS | I | ST | SPI1 Data In |
| SDO1 | PPS | PPS | PPS | PPS | O | — | SPI1 Data Out |
| SS1 | PPS | PPS | PPS | PPS | I/O | ST | SPI1 Slave Synchronization Or Frame Pulse I/O |
| Serial Peripheral Interface 2 | | | | | | | |
| SCK2 | 4 | 10 | B6 | 14 | I/O | ST | SPI2 Synchronous Serial Clock Input/output |
| SDI2 | PPS | PPS | PPS | PPS | I | ST | SPI2 Data In |
| SDO2 | PPS | PPS | PPS | PPS | O | — | SPI2 Data Out |
| SS2 | PPS | PPS | PPS | PPS | I/O | ST | SPI2 Slave Synchronization Or Frame Pulse I/O |
| Serial Peripheral Interface 3 | | | | | | | |
| SCK3 | 29 | 43 | A28 | 61 | I/O | ST | SPI3 Synchronous Serial Clock Input/Output |
| SDI3 | PPS | PPS | PPS | PPS | I | ST | SPI3 Data In |
| SDO3 | PPS | PPS | PPS | PPS | O | — | SPI3 Data Out |
| SS3 | PPS | PPS | PPS | PPS | I/O | ST | SPI3 Slave Synchronization Or Frame Pulse I/O |
| Serial Peripheral Interface 4 | | | | | | | |
| SCK4 | 44 | 69 | A46 | 98 | I/O | ST | SPI4 Synchronous Serial Clock Input/Output |
| SDI4 | PPS | PPS | PPS | PPS | I | ST | SPI4 Data In |
| SDO4 | PPS | PPS | PPS | PPS | O | — | SPI4 Data Out |
| SS4 | PPS | PPS | PPS | PPS | I/O | ST | SPI4 Slave Synchronization Or Frame Pulse I/O |
| Serial Peripheral Interface 5 | | | | | | | |
| SCK5 | — | 39 | A26 | 57 | I/O | ST | SPI5 Synchronous Serial Clock Input/Output |
| SDI5 | — | PPS | PPS | PPS | I | ST | SPI5 Data In |
| SDO5 | — | PPS | PPS | PPS | O | — | SPI5 Data Out |
| SS5 | — | PPS | PPS | PPS | I/O | ST | SPI5 Slave Synchronization Or Frame Pulse I/O |
| Serial Peripheral Interface 6 | | | | | | | |
| SCK6 | — | 48 | A32 | 70 | I/O | ST | SPI6 Synchronous Serial Clock Input/Output |
| SDI6 | — | PPS | PPS | PPS | I | ST | SPI6 Data In |
| SDO6 | — | PPS | PPS | PPS | O | — | SPI6 Data Out |
| SS6 | — | PPS | PPS | PPS | I/O | ST | SPI6 Slave Synchronization Or Frame Pulse I/O |

Legend: CMOS = CMOS-compatible input or output
 ST = Schmitt Trigger input with CMOS levels
 TTL = Transistor-transistor Logic input buffer
 Analog = Analog input
 O = Output
 PPS = Peripheral Pin Select
 P = Power
 I = Input

PIC32MZ Embedded Connectivity with Floating Point Unit (EF) Family

TABLE 1-10: I2C1 THROUGH I2C5 PINOUT I/O DESCRIPTIONS

| Pin Name | Pin Number | | | | Pin Type | Buffer Type | Description |
|-----------------------------------|-----------------|--------------|--------------|-------------------|----------|-------------|--|
| | 64-pin QFN/TQFP | 100-pin TQFP | 124-pin VTLA | 144-pin TQFP/LQFP | | | |
| Inter-Integrated Circuit 1 | | | | | | | |
| SCL1 | 44 | 66 | B37 | 95 | I/O | ST | I2C1 Synchronous Serial Clock Input/Output |
| SDA1 | 43 | 67 | A45 | 96 | I/O | ST | I2C1 Synchronous Serial Data Input/Output |
| Inter-Integrated Circuit 2 | | | | | | | |
| SCL2 | — | 59 | A41 | 85 | I/O | ST | I2C2 Synchronous Serial Clock Input/Output |
| SDA2 | — | 60 | B34 | 86 | I/O | ST | I2C2 Synchronous Serial Data Input/Output |
| Inter-Integrated Circuit 3 | | | | | | | |
| SCL3 | 51 | 58 | A39 | 80 | I/O | ST | I2C3 Synchronous Serial Clock Input/Output |
| SDA3 | 50 | 57 | B31 | 79 | I/O | ST | I2C3 Synchronous Serial Data Input/Output |
| Inter-Integrated Circuit 4 | | | | | | | |
| SCL4 | 6 | 12 | B7 | 16 | I/O | ST | I2C4 Synchronous Serial Clock Input/Output |
| SDA4 | 5 | 11 | A8 | 15 | I/O | ST | I2C4 Synchronous Serial Data Input/Output |
| Inter-Integrated Circuit 5 | | | | | | | |
| SCL5 | 42 | 65 | A44 | 91 | I/O | ST | I2C5 Synchronous Serial Clock Input/Output |
| SDA5 | 41 | 64 | B36 | 90 | I/O | ST | I2C5 Synchronous Serial Data Input/Output |

Legend: CMOS = CMOS-compatible input or output Analog = Analog input P = Power
 ST = Schmitt Trigger input with CMOS levels O = Output I = Input
 TTL = Transistor-transistor Logic input buffer PPS = Peripheral Pin Select

TABLE 1-11: COMPARATOR 1, COMPARATOR 2 AND CVREF PINOUT I/O DESCRIPTIONS

| Pin Name | Pin Number | | | | Pin Type | Buffer Type | Description |
|-------------------------------------|-----------------|--------------|--------------|-------------------|----------|-------------|---|
| | 64-pin QFN/TQFP | 100-pin TQFP | 124-pin VTLA | 144-pin TQFP/LQFP | | | |
| Comparator Voltage Reference | | | | | | | |
| CVREF+ | 16 | 29 | A20 | 40 | I | Analog | Comparator Voltage Reference (High) Input |
| CVREF- | 15 | 28 | B15 | 39 | I | Analog | Comparator Voltage Reference (Low) Input |
| CVREFOUT | 23 | 34 | B19 | 49 | O | Analog | Comparator Voltage Reference Output |
| Comparator 1 | | | | | | | |
| C1INA | 11 | 20 | B11 | 25 | I | Analog | Comparator 1 Positive Input |
| C1INB | 12 | 21 | A13 | 26 | I | Analog | |
| C1INC | 5 | 11 | A8 | 15 | I | Analog | |
| C1IND | 4 | 10 | B6 | 14 | I | Analog | |
| C1OUT | PPS | PPS | PPS | PPS | O | — | Comparator 1 Output |
| Comparator 2 | | | | | | | |
| C2INA | 13 | 22 | A14 | 31 | I | Analog | Comparator 2 Positive Input |
| C2INB | 14 | 23 | A16 | 34 | I | Analog | |
| C2INC | 10 | 16 | B9 | 21 | I | Analog | |
| C2IND | 6 | 12 | B7 | 16 | I | Analog | |
| C2OUT | PPS | PPS | PPS | PPS | O | — | Comparator 2 Output |

Legend: CMOS = CMOS-compatible input or output Analog = Analog input P = Power
 ST = Schmitt Trigger input with CMOS levels O = Output I = Input
 TTL = Transistor-transistor Logic input buffer PPS = Peripheral Pin Select

PIC32MZ Embedded Connectivity with Floating Point Unit (EF) Family

TABLE 1-12: PMP PINOUT I/O DESCRIPTIONS

| Pin Name | Pin Number | | | | Pin Type | Buffer Type | Description |
|----------|-----------------|--------------|--------------|-------------------|----------|-------------|--|
| | 64-pin QFN/TQFP | 100-pin TQFP | 124-pin VTLA | 144-pin TQFP/LQFP | | | |
| PMA0 | 30 | 44 | B24 | 30 | I/O | TTL/ST | Parallel Master Port Address bit 0 Input (Buffered Slave modes) and Output (Master modes) |
| PMA1 | 29 | 43 | A28 | 51 | I/O | TTL/ST | Parallel Master Port Address bit 1 Input (Buffered Slave modes) and Output (Master modes) |
| PMA2 | 10 | 16 | B9 | 21 | O | — | Parallel Master Port Address (Demultiplexed Master modes) |
| PMA3 | 6 | 12 | B7 | 52 | O | — | |
| PMA4 | 5 | 11 | A8 | 68 | O | — | |
| PMA5 | 4 | 2 | B1 | 2 | O | — | |
| PMA6 | 16 | 6 | B3 | 6 | O | — | |
| PMA7 | 22 | 33 | A23 | 48 | O | — | |
| PMA8 | 42 | 65 | A44 | 91 | O | — | |
| PMA9 | 41 | 64 | B36 | 90 | O | — | |
| PMA10 | 21 | 32 | B18 | 47 | O | — | |
| PMA11 | 27 | 41 | A27 | 29 | O | — | |
| PMA12 | 24 | 7 | A6 | 11 | O | — | |
| PMA13 | 23 | 34 | B19 | 28 | O | — | |
| PMA14 | 45 | 61 | A42 | 87 | O | — | |
| PMA15 | 43 | 68 | B38 | 97 | O | — | |
| PMCS1 | 45 | 61 | A42 | 87 | O | — | |
| PMCS2 | 43 | 68 | B38 | 97 | O | — | Parallel Master Port Chip Select 2 Strobe |
| PMD0 | 58 | 91 | B52 | 135 | I/O | TTL/ST | Parallel Master Port Data (Demultiplexed Master mode) or Address/Data (Multiplexed Master modes) |
| PMD1 | 61 | 94 | A64 | 138 | I/O | TTL/ST | |
| PMD2 | 62 | 98 | A66 | 142 | I/O | TTL/ST | |
| PMD3 | 63 | 99 | B56 | 143 | I/O | TTL/ST | |
| PMD4 | 64 | 100 | A67 | 144 | I/O | TTL/ST | |
| PMD5 | 1 | 3 | A3 | 3 | I/O | TTL/ST | |
| PMD6 | 2 | 4 | B2 | 4 | I/O | TTL/ST | |
| PMD7 | 3 | 5 | A4 | 5 | I/O | TTL/ST | |
| PMD8 | — | 88 | B50 | 128 | I/O | TTL/ST | |
| PMD9 | — | 87 | A60 | 127 | I/O | TTL/ST | |
| PMD10 | — | 86 | B49 | 125 | I/O | TTL/ST | |
| PMD11 | — | 85 | A59 | 124 | I/O | TTL/ST | |
| PMD12 | — | 79 | B43 | 112 | I/O | TTL/ST | |
| PMD13 | — | 80 | A54 | 113 | I/O | TTL/ST | |
| PMD14 | — | 77 | B42 | 110 | I/O | TTL/ST | |
| PMD15 | — | 78 | A53 | 111 | I/O | TTL/ST | |
| PMALL | 30 | 44 | B24 | 30 | O | — | Parallel Master Port Address Latch Enable Low Byte (Multiplexed Master modes) |
| PMALH | 29 | 43 | A28 | 51 | O | — | Parallel Master Port Address Latch Enable High Byte (Multiplexed Master modes) |
| PMRD | 53 | 9 | A7 | 13 | O | — | Parallel Master Port Read Strobe |
| PMWR | 52 | 8 | B5 | 12 | O | — | Parallel Master Port Write Strobe |

Legend: CMOS = CMOS-compatible input or output
 ST = Schmitt Trigger input with CMOS levels
 TTL = Transistor-transistor Logic input buffer
 Analog = Analog input
 O = Output
 PPS = Peripheral Pin Select
 P = Power
 I = Input

PIC32MZ Embedded Connectivity with Floating Point Unit (EF) Family

TABLE 1-13: EBI PINOUT I/O DESCRIPTIONS

| Pin Name | Pin Number | | | | Pin Type | Buffer Type | Description |
|----------|-----------------|--------------|--------------|-------------------|----------|-------------|-------------------------------------|
| | 64-pin QFN/TQFP | 100-pin TQFP | 124-pin VTLA | 144-pin TQFP/LQFP | | | |
| EBIA0 | — | 44 | B24 | 30 | O | — | External Bus Interface Address Bus |
| EBIA1 | — | 43 | A28 | 51 | O | — | |
| EBIA2 | — | 16 | B9 | 21 | O | — | |
| EBIA3 | — | 12 | B7 | 52 | O | — | |
| EBIA4 | — | 11 | A8 | 68 | O | — | |
| EBIA5 | — | 2 | B1 | 2 | O | — | |
| EBIA6 | — | 6 | B3 | 6 | O | — | |
| EBIA7 | — | 33 | A23 | 48 | O | — | |
| EBIA8 | — | 65 | A44 | 91 | O | — | |
| EBIA9 | — | 64 | B36 | 90 | O | — | |
| EBIA10 | — | 32 | B18 | 47 | O | — | |
| EBIA11 | — | 41 | A27 | 29 | O | — | |
| EBIA12 | — | 7 | A6 | 11 | O | — | |
| EBIA13 | — | 34 | B19 | 28 | O | — | |
| EBIA14 | — | 61 | A42 | 87 | O | — | |
| EBIA15 | — | 68 | B38 | 97 | O | — | |
| EBIA16 | — | 17 | A11 | 19 | O | — | |
| EBIA17 | — | 40 | B22 | 53 | O | — | |
| EBIA18 | — | 39 | A26 | 92 | O | — | |
| EBIA19 | — | 38 | B21 | 93 | O | — | |
| EBIA20 | — | — | — | 94 | O | — | |
| EBIA21 | — | — | — | 126 | O | — | |
| EBIA22 | — | — | — | 117 | O | — | |
| EBIA23 | — | — | — | 103 | O | — | |
| EBID0 | — | 91 | B52 | 135 | I/O | ST | External Bus Interface Data I/O Bus |
| EBID1 | — | 94 | A64 | 138 | I/O | ST | |
| EBID2 | — | 98 | A66 | 142 | I/O | ST | |
| EBID3 | — | 99 | B56 | 143 | I/O | ST | |
| EBID4 | — | 100 | A67 | 144 | I/O | ST | |
| EBID5 | — | 3 | A3 | 3 | I/O | ST | |
| EBID6 | — | 4 | B2 | 4 | I/O | ST | |
| EBID7 | — | 5 | A4 | 5 | I/O | ST | |
| EBID8 | — | 88 | B50 | 128 | I/O | ST | |
| EBID9 | — | 87 | A60 | 127 | I/O | ST | |
| EBID10 | — | 86 | B49 | 125 | I/O | ST | |
| EBID11 | — | 85 | A59 | 124 | I/O | ST | |
| EBID12 | — | 79 | B43 | 112 | I/O | ST | |
| EBID13 | — | 80 | A54 | 113 | I/O | ST | |
| EBID14 | — | 77 | B42 | 110 | I/O | ST | |
| EBID15 | — | 78 | A53 | 111 | I/O | ST | |
| EBIBS0 | — | — | — | 9 | O | — | External Bus Interface Byte Select |
| EBIBS1 | — | — | — | 10 | O | — | |
| EBICS0 | — | 59 | A41 | 131 | O | — | External Bus Interface Chip Select |
| EBICS1 | — | — | — | 132 | O | — | |
| EBICS2 | — | — | — | 133 | O | — | |
| EBICS3 | — | — | — | 134 | O | — | |

Legend: CMOS = CMOS-compatible input or output Analog = Analog input P = Power
 ST = Schmitt Trigger input with CMOS levels O = Output I = Input
 TTL = Transistor-transistor Logic input buffer PPS = Peripheral Pin Select

PIC32MZ Embedded Connectivity with Floating Point Unit (EF) Family

TABLE 1-13: EBI PINOUT I/O DESCRIPTIONS (CONTINUED)

| Pin Name | Pin Number | | | | Pin Type | Buffer Type | Description |
|----------|-----------------|--------------|--------------|-------------------|----------|-------------|--|
| | 64-pin QFN/TQFP | 100-pin TQFP | 124-pin VTLA | 144-pin TQFP/LQFP | | | |
| EBIOE | — | 9 | A7 | 13 | O | — | External Bus Interface Output Enable |
| EBIRDY1 | — | 60 | B34 | 86 | I | ST | External Bus Interface Ready Input |
| EBIRDY2 | — | 58 | A39 | 84 | I | ST | |
| EBIRDY3 | — | 57 | B45 | 116 | I | ST | |
| EBIRP | — | — | — | 45 | O | — | External Bus Interface Flash Reset Pin |
| EBIWE | — | 8 | B5 | 12 | O | — | External Bus Interface Write Enable |

Legend: CMOS = CMOS-compatible input or output
 ST = Schmitt Trigger input with CMOS levels
 TTL = Transistor-transistor Logic input buffer

Analog = Analog input
 O = Output
 PPS = Peripheral Pin Select

P = Power
 I = Input

PIC32MZ Embedded Connectivity with Floating Point Unit (EF) Family

TABLE 1-14: USB PINOUT I/O DESCRIPTIONS

| Pin Name | Pin Number | | | | Pin Type | Buffer Type | Description |
|----------|-----------------|--------------|--------------|-------------------|----------|-------------|---|
| | 64-pin QFN/TQFP | 100-pin TQFP | 124-pin VTLA | 144-pin TQFP/LQFP | | | |
| VBUS | 33 | 51 | A35 | 73 | I | Analog | USB bus power monitor |
| VUSB3V3 | 34 | 52 | A36 | 74 | P | — | USB internal transceiver supply. If the USB module is <i>not</i> used, this pin must be connected to Vss. When connected, the shared pin functions on USBID will <i>not</i> be available. |
| D+ | 37 | 55 | B30 | 77 | I/O | Analog | USB D+ |
| D- | 36 | 54 | A37 | 76 | I/O | Analog | USB D- |
| USBID | 38 | 56 | A38 | 78 | I | ST | USB OTG ID detect |

Legend: CMOS = CMOS-compatible input or output
 ST = Schmitt Trigger input with CMOS levels
 TTL = Transistor-transistor Logic input buffer
 Analog = Analog input
 O = Output
 PPS = Peripheral Pin Select
 P = Power
 I = Input

TABLE 1-15: CAN1 AND CAN2 PINOUT I/O DESCRIPTIONS

| Pin Name | Pin Number | | | | Pin Type | Buffer Type | Description |
|----------|-----------------|--------------|--------------|-------------------|----------|-------------|-----------------------|
| | 64-pin QFN/TQFP | 100-pin TQFP | 124-pin VTLA | 144-pin TQFP/LQFP | | | |
| C1TX | PPS | PPS | PPS | PPS | O | — | CAN1 Bus Transmit Pin |
| C1RX | PPS | PPS | PPS | PPS | I | ST | CAN1 Bus Receive Pin |
| C2TX | PPS | PPS | PPS | PPS | O | — | CAN2 Bus Transmit Pin |
| C2RX | PPS | PPS | PPS | PPS | I | ST | CAN2 Bus Receive Pin |

Legend: CMOS = CMOS-compatible input or output
 ST = Schmitt Trigger input with CMOS levels
 TTL = Transistor-transistor Logic input buffer
 Analog = Analog input
 O = Output
 PPS = Peripheral Pin Select
 P = Power
 I = Input

PIC32MZ Embedded Connectivity with Floating Point Unit (EF) Family

TABLE 1-16: ETHERNET MII I/O DESCRIPTIONS

| Pin Name | Pin Number | | | | Pin Type | Buffer Type | Description |
|----------|-----------------|--------------|--------------|-------------------|----------|-------------|--------------------------------|
| | 64-pin QFN/TQFP | 100-pin TQFP | 124-pin VTLA | 144-pin TQFP/LQFP | | | |
| ERXD0 | 61 | 41 | B32 | 81 | I | ST | Ethernet Receive Data 0 |
| ERXD1 | 58 | 42 | B26 | 66 | I | ST | Ethernet Receive Data 1 |
| ERXD2 | 57 | 43 | A31 | 67 | I | ST | Ethernet Receive Data 2 |
| ERXD3 | 56 | 44 | A40 | 82 | I | ST | Ethernet Receive Data 3 |
| ERXERR | 64 | 35 | A30 | 65 | I | ST | Ethernet Receive Error Input |
| ERXDV | 62 | 12 | B40 | 101 | I | ST | Ethernet Receive Data Valid |
| ERXCLK | 63 | 16 | B12 | 27 | I | ST | Ethernet Receive Clock |
| ETXD0 | 2 | 86 | A5 | 7 | O | — | Ethernet Transmit Data 0 |
| ETXD1 | 3 | 85 | B4 | 8 | O | — | Ethernet Transmit Data 1 |
| ETXD2 | 43 | 79 | B17 | 43 | O | — | Ethernet Transmit Data 2 |
| ETXD3 | 46 | 80 | A22 | 44 | O | — | Ethernet Transmit Data 3 |
| ETXERR | 50 | 87 | B44 | 114 | O | — | Ethernet Transmit Error |
| ETXEN | 1 | 77 | A57 | 120 | O | — | Ethernet Transmit Enable |
| ETXCLK | 51 | 78 | B47 | 121 | I | ST | Ethernet Transmit Clock |
| ECOL | 44 | 10 | B33 | 83 | I | ST | Ethernet Collision Detect |
| ECRS | 45 | 11 | A47 | 100 | I | ST | Ethernet Carrier Sense |
| EMDC | 30 | 70 | B39 | 99 | O | — | Ethernet Management Data Clock |
| EMDIO | 49 | 71 | A55 | 115 | I/O | — | Ethernet Management Data |

Legend: CMOS = CMOS-compatible input or output Analog = Analog input P = Power
 ST = Schmitt Trigger input with CMOS levels O = Output I = Input
 TTL = Transistor-transistor Logic input buffer PPS = Peripheral Pin Select

TABLE 1-17: ETHERNET RMII PINOUT I/O DESCRIPTIONS

| Pin Name | Pin Number | | | | Pin Type | Buffer Type | Description |
|-------------------------------|-----------------|--------------|--------------|-------------------|----------|-------------|-----------------------------------|
| | 64-pin QFN/TQFP | 100-pin TQFP | 124-pin VTLA | 144-pin TQFP/LQFP | | | |
| Ethernet MII Interface | | | | | | | |
| ERXD0 | 61 | 41 | B32 | 81 | I | ST | Ethernet Receive Data 0 |
| ERXD1 | 58 | 42 | B26 | 66 | I | ST | Ethernet Receive Data 1 |
| ERXERR | 64 | 35 | A30 | 65 | I | ST | Ethernet Receive Error Input |
| ETXD0 | 2 | 86 | A5 | 7 | O | — | Ethernet Transmit Data 0 |
| ETXD1 | 3 | 85 | B4 | 8 | O | — | Ethernet Transmit Data 1 |
| ETXEN | 1 | 77 | A57 | 120 | O | — | Ethernet Transmit Enable |
| EMDC | 30 | 70 | B39 | 99 | O | — | Ethernet Management Data Clock |
| EMDIO | 49 | 71 | A55 | 115 | I/O | — | Ethernet Management Data |
| EREFCLK | 63 | 16 | B12 | 27 | I | ST | Ethernet Reference Clock |
| ECRSDV | 62 | 12 | B40 | 101 | I | ST | Ethernet Carrier Sense Data Valid |

Legend: CMOS = CMOS-compatible input or output Analog = Analog input P = Power
 ST = Schmitt Trigger input with CMOS levels O = Output I = Input
 TTL = Transistor-transistor Logic input buffer PPS = Peripheral Pin Select

PIC32MZ Embedded Connectivity with Floating Point Unit (EF) Family

TABLE 1-18: ALTERNATE ETHERNET MII PINOUT I/O DESCRIPTIONS

| Pin Name | Pin Number | | | | Pin Type | Buffer Type | Description |
|----------|-----------------|--------------|--------------|-------------------|----------|-------------|--|
| | 64-pin QFN/TQFP | 100-pin TQFP | 124-pin VTLA | 144-pin TQFP/LQFP | | | |
| AERXD0 | — | 18 | — | — | I | ST | Alternate Ethernet Receive Data 0 |
| AERXD1 | — | 19 | — | — | I | ST | Alternate Ethernet Receive Data 1 |
| AERXD2 | — | 28 | — | — | I | ST | Alternate Ethernet Receive Data 2 |
| AERXD3 | — | 29 | — | — | I | ST | Alternate Ethernet Receive Data 3 |
| AERXERR | — | 1 | — | — | I | ST | Alternate Ethernet Receive Error Input |
| AERXDV | — | 12 | — | — | I | ST | Alternate Ethernet Receive Data Valid |
| AERXCLK | — | 16 | — | — | I | ST | Alternate Ethernet Receive Clock |
| AETXD0 | — | 47 | — | — | O | — | Alternate Ethernet Transmit Data 0 |
| AETXD1 | — | 48 | — | — | O | — | Alternate Ethernet Transmit Data 1 |
| AETXD2 | — | 44 | — | — | O | — | Alternate Ethernet Transmit Data 2 |
| AETXD3 | — | 43 | — | — | O | — | Alternate Ethernet Transmit Data 3 |
| AETXERR | — | 35 | — | — | O | — | Alternate Ethernet Transmit Error |
| AECOL | — | 42 | — | — | I | ST | Alternate Ethernet Collision Detect |
| AECRS | — | 41 | — | — | I | ST | Alternate Ethernet Carrier Sense |
| AETXCLK | — | 66 | — | — | I | ST | Alternate Ethernet Transmit Clock |
| AEMDC | — | 70 | — | — | O | — | Alternate Ethernet Management Data Clock |
| AEMDIO | — | 71 | — | — | I/O | — | Alternate Ethernet Management Data |
| AETXEN | — | 67 | — | — | O | — | Alternate Ethernet Transmit Enable |

Legend: CMOS = CMOS-compatible input or output Analog = Analog input P = Power
 ST = Schmitt Trigger input with CMOS levels O = Output I = Input
 TTL = Transistor-transistor Logic input buffer PPS = Peripheral Pin Select

TABLE 1-19: ALTERNATE ETHERNET RMII PINOUT I/O DESCRIPTIONS

| Pin Name | Pin Number | | | | Pin Type | Buffer Type | Description |
|----------|-----------------|--------------|--------------|-------------------|----------|-------------|---|
| | 64-pin QFN/TQFP | 100-pin TQFP | 124-pin VTLA | 144-pin TQFP/LQFP | | | |
| AERXD0 | 43 | 18 | — | — | I | ST | Alternate Ethernet Receive Data 0 |
| AERXD1 | 46 | 19 | — | — | I | ST | Alternate Ethernet Receive Data 1 |
| AERXERR | 51 | 1 | — | — | I | ST | Alternate Ethernet Receive Error Input |
| AETXD0 | 57 | 47 | — | — | O | — | Alternate Ethernet Transmit Data 0 |
| AETXD1 | 56 | 48 | — | — | O | — | Alternate Ethernet Transmit Data 1 |
| AEMDC | 30 | 70 | — | — | O | — | Alternate Ethernet Management Data Clock |
| AEMDIO | 49 | 71 | — | — | I/O | — | Alternate Ethernet Management Data |
| AETXEN | 50 | 67 | — | — | O | — | Alternate Ethernet Transmit Enable |
| AEREFCLK | 45 | 16 | — | — | I | ST | Alternate Ethernet Reference Clock |
| AECRSDV | 62 | 12 | — | — | I | ST | Alternate Ethernet Carrier Sense Data Valid |

Legend: CMOS = CMOS-compatible input or output Analog = Analog input P = Power
 ST = Schmitt Trigger input with CMOS levels O = Output I = Input
 TTL = Transistor-transistor Logic input buffer PPS = Peripheral Pin Select

PIC32MZ Embedded Connectivity with Floating Point Unit (EF) Family

TABLE 1-20: SQI1 PINOUT I/O DESCRIPTIONS

| Pin Name | Pin Number | | | | Pin Type | Buffer Type | Description |
|----------|-----------------|--------------|--------------|-------------------|----------|-------------|-------------------------------------|
| | 64-pin QFN/TQFP | 100-pin TQFP | 124-pin VTLA | 144-pin TQFP/LQFP | | | |
| SQICLK | 57 | 89 | A61 | 129 | O | — | Serial Quad Interface Clock |
| SQICS0 | 52 | 81 | A56 | 118 | O | — | Serial Quad Interface Chip Select 0 |
| SQICS1 | 53 | 82 | B46 | 119 | O | — | Serial Quad Interface Chip Select 1 |
| SQID0 | 58 | 97 | B55 | 141 | I/O | ST | Serial Quad Interface Data 0 |
| SQID1 | 61 | 96 | A65 | 140 | I/O | ST | Serial Quad Interface Data 1 |
| SQID2 | 62 | 95 | B54 | 139 | I/O | ST | Serial Quad Interface Data 2 |
| SQID3 | 63 | 90 | B51 | 130 | I/O | ST | Serial Quad Interface Data 3 |

Legend: CMOS = CMOS-compatible input or output
 ST = Schmitt Trigger input with CMOS levels
 TTL = Transistor-transistor Logic input buffer
 Analog = Analog input
 O = Output
 PPS = Peripheral Pin Select
 P = Power
 I = Input

TABLE 1-21: POWER, GROUND, AND VOLTAGE REFERENCE PINOUT I/O DESCRIPTIONS

| Pin Name | Pin Number | | | | Pin Type | Buffer Type | Description |
|--------------------------|-----------------------|--------------------------------|--|---------------------------------------|----------|-------------|---|
| | 64-pin QFN/TQFP | 100-pin TQFP | 124-pin VTLA | 144-pin TQFP/LQFP | | | |
| Power and Ground | | | | | | | |
| AVDD | 19 | 30 | B16 | 41 | P | P | Positive supply for analog modules. This pin must be connected at all times. |
| AVSS | 20 | 31 | A21 | 42 | P | P | Ground reference for analog modules. This pin must be connected at all times |
| VDD | 8, 26, 39, 54, 60 | 14, 37, 46, 62, 74, 83, 93 | B8, A15, A25, B25, B35, A50, A58, B53 | 18, 33, 55, 64, 88, 107, 122, 137 | P | — | Positive supply for peripheral logic and I/O pins. This pin must be connected at all times. |
| VSS | 7, 25, 35, 40, 55, 59 | 13, 36, 45, 53, 63, 75, 84, 92 | A9, B13, B20, B29, A29, A43, A51, B48, A63 | 17, 32, 54, 63, 75, 89, 108, 123, 136 | P | — | Ground reference for logic, I/O pins, and USB. This pin must be connected at all times. |
| Voltage Reference | | | | | | | |
| VREF+ | 16 | 29 | A20 | 40 | I | Analog | Analog Voltage Reference (High) Input |
| VREF- | 15 | 28 | B15 | 39 | I | Analog | Analog Voltage Reference (Low) Input |

Legend: CMOS = CMOS-compatible input or output
 ST = Schmitt Trigger input with CMOS levels
 TTL = Transistor-transistor Logic input buffer
 Analog = Analog input
 O = Output
 PPS = Peripheral Pin Select
 P = Power
 I = Input

PIC32MZ Embedded Connectivity with Floating Point Unit (EF) Family

TABLE 1-22: JTAG, TRACE, AND PROGRAMMING/DEBUGGING PINOUT I/O DESCRIPTIONS

| Pin Name | Pin Number | | | | Pin Type | Buffer Type | Description |
|------------------------------|-----------------|--------------|--------------|-------------------|----------|-------------|--|
| | 64-pin QFN/TQFP | 100-pin TQFP | 124-pin VTLA | 144-pin TQFP/LQFP | | | |
| JTAG | | | | | | | |
| TCK | 27 | 38 | B21 | 56 | I | ST | JTAG Test Clock Input Pin |
| TDI | 28 | 39 | A26 | 57 | I | ST | JTAG Test Data Input Pin |
| TDO | 24 | 40 | B22 | 58 | O | — | JTAG Test Data Output Pin |
| TMS | 23 | 17 | A11 | 22 | I | ST | JTAG Test Mode Select Pin |
| Trace | | | | | | | |
| TRCLK | 57 | 89 | A61 | 129 | O | — | Trace Clock |
| TRD0 | 58 | 97 | B55 | 141 | O | — | Trace Data bits 0-3 |
| TRD1 | 61 | 96 | A65 | 140 | O | — | |
| TRD2 | 62 | 95 | B54 | 139 | O | — | |
| TRD3 | 63 | 90 | B51 | 130 | O | — | |
| Programming/Debugging | | | | | | | |
| PGED1 | 16 | 25 | A18 | 36 | I/O | ST | Data I/O pin for Programming/Debugging Communication Channel 1 |
| PGEC1 | 15 | 24 | A17 | 35 | I | ST | Clock input pin for Programming/Debugging Communication Channel 1 |
| PGED2 | 18 | 27 | A19 | 38 | I/O | ST | Data I/O pin for Programming/Debugging Communication Channel 2 |
| PGEC2 | 17 | 26 | B14 | 37 | I | ST | Clock input pin for Programming/Debugging Communication Channel 2 |
| MCLR | 9 | 15 | A10 | 20 | I/P | ST | Master Clear (Reset) input. This pin is an active-low Reset to the device. |

Legend: CMOS = CMOS-compatible input or output
 ST = Schmitt Trigger input with CMOS levels
 TTL = Transistor-transistor Logic input buffer
 Analog = Analog input
 O = Output
 PPS = Peripheral Pin Select
 P = Power
 I = Input

PIC32MZ Embedded Connectivity with Floating Point Unit (EF) Family

NOTES:

2.0 GUIDELINES FOR GETTING STARTED WITH 32-BIT MICROCONTROLLERS

Note 1: This data sheet summarizes the features of the PIC32MZ EF family of devices. It is not intended to be a comprehensive reference source. To complement the information in this data sheet, refer to the “PIC32 Family Reference Manual”, which is available from the Microchip web site (www.microchip.com/PIC32).

2.1 Basic Connection Requirements

Getting started with the PIC32MZ EF family of 32-bit Microcontrollers (MCUs) requires attention to a minimal set of device pin connections before proceeding with development. The following is a list of pin names, which must always be connected:

- All VDD and VSS pins (see [2.2 “Decoupling Capacitors”](#))
- All AVDD and AVSS pins, even if the ADC module is not used (see [2.2 “Decoupling Capacitors”](#))
- MCLR pin (see [2.3 “Master Clear \(MCLR\) Pin”](#))
- PGECx/PGEDx pins, used for In-Circuit Serial Programming™ (ICSP™) and debugging purposes (see [2.4 “ICSP Pins”](#))
- OSC1 and OSC2 pins, when external oscillator source is used (see [2.7 “External Oscillator Pins”](#))

The following pin(s) may be required as well:

VREF+/VREF- pins, used when external voltage reference for the ADC module is implemented.

Note: The AVDD and AVSS pins must be connected, regardless of ADC use and the ADC voltage reference source.

2.2 Decoupling Capacitors

The use of decoupling capacitors on power supply pins, such as VDD, VSS, AVDD and AVSS is required. See [Figure 2-1](#).

Consider the following criteria when using decoupling capacitors:

- **Value and type of capacitor:** A value of 0.1 μF (100 nF), 10-20V is recommended. The capacitor should be a low Equivalent Series Resistance (low-ESR) capacitor and have resonance frequency in the range of 20 MHz and higher. It is further recommended that ceramic capacitors be used.
- **Placement on the printed circuit board:** The decoupling capacitors should be placed as close to the pins as possible. It is recommended that the capacitors be placed on the same side of the board as the device. If space is constricted, the capacitor can be placed on another layer on the PCB using a via; however, ensure that the trace length from the pin to the capacitor is within one-quarter inch (6 mm) in length.
- **Handling high frequency noise:** If the board is experiencing high frequency noise, upward of tens of MHz, add a second ceramic-type capacitor in parallel to the above described decoupling capacitor. The value of the second capacitor can be in the range of 0.01 μF to 0.001 μF . Place this second capacitor next to the primary decoupling capacitor. In high-speed circuit designs, consider implementing a decade pair of capacitances as close to the power and ground pins as possible. For example, 0.1 μF in parallel with 0.001 μF .
- **Maximizing performance:** On the board layout from the power supply circuit, run the power and return traces to the decoupling capacitors first, and then to the device pins. This ensures that the decoupling capacitors are first in the power chain. Equally important is to keep the trace length between the capacitor and the power pins to a minimum thereby reducing PCB track inductance.

PIC32MZ Embedded Connectivity with Floating Point Unit (EF) Family

FIGURE 2-1: RECOMMENDED MINIMUM CONNECTION

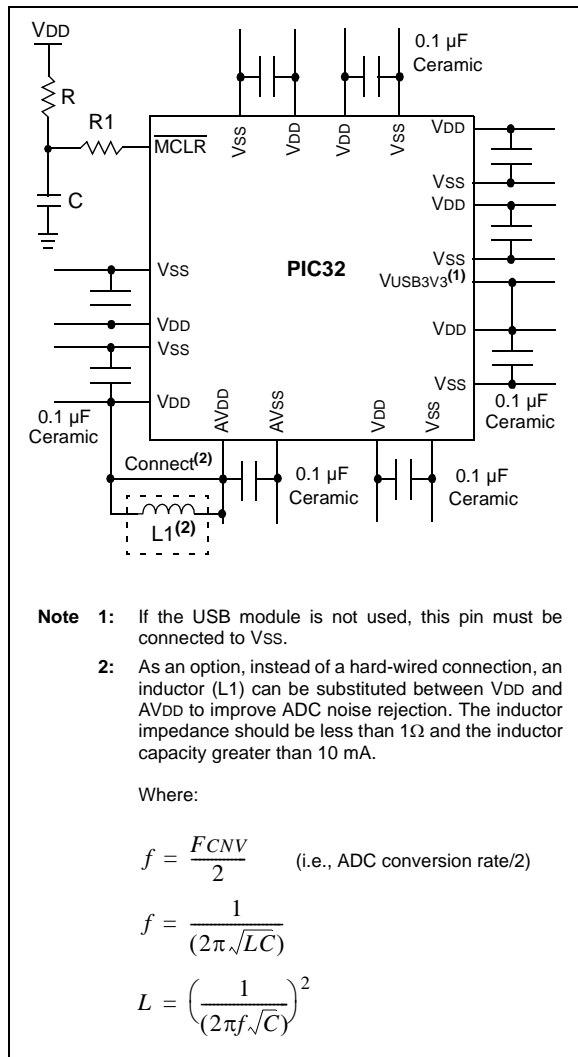

2.2.1 BULK CAPACITORS

The use of a bulk capacitor is recommended to improve power supply stability. Typical values range from 4.7 µF to 47 µF. This capacitor should be located as close to the device as possible.

2.3 Master Clear ($\overline{\text{MCLR}}$) Pin

The $\overline{\text{MCLR}}$ pin provides for two specific device functions:

- Device Reset
- Device programming and debugging

Pulling The $\overline{\text{MCLR}}$ pin low generates either a device Reset or a POR, depending on the setting of the SMCLR bit (DEVCFG0<15>). Figure 2-2 illustrates a typical $\overline{\text{MCLR}}$ circuit. During device programming and debugging, the resistance and capacitance that can be added to the pin must be considered. Device programmers and debuggers drive the $\overline{\text{MCLR}}$ pin. Consequently, specific voltage levels (V_{IH} and V_{IL}) and fast signal transitions must not be adversely affected. Therefore, specific values of R and C will need to be adjusted based on the application and PCB requirements.

For example, as illustrated in Figure 2-2, it is recommended that the capacitor C be isolated from the $\overline{\text{MCLR}}$ pin during programming and debugging operations.

Place the components illustrated in Figure 2-2 within one-quarter inch (6 mm) from the $\overline{\text{MCLR}}$ pin.

FIGURE 2-2: EXAMPLE OF $\overline{\text{MCLR}}$ PIN CONNECTIONS

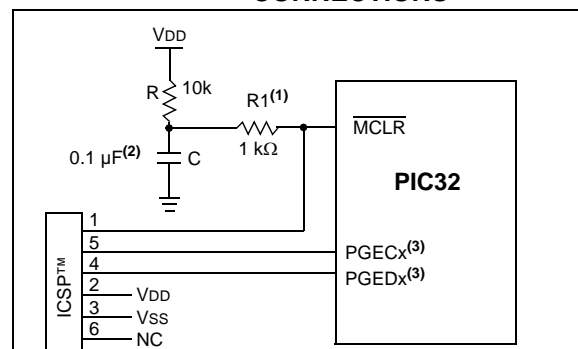

- Note 1:** $470\Omega \leq R1 \leq 1\Omega$ will limit any current flowing into $\overline{\text{MCLR}}$ from the external capacitor C, in the event of $\overline{\text{MCLR}}$ pin breakdown, due to Electrostatic Discharge (ESD) or Electrical Overstress (EOS). Ensure that the $\overline{\text{MCLR}}$ pin V_{IH} and V_{IL} specifications are met without interfering with the Debug/Programmer tools.
- Note 2:** The capacitor can be sized to prevent unintentional Resets from brief glitches or to extend the device Reset period during POR.
- Note 3:** No pull-ups or bypass capacitors are allowed on active debug/program PGECx/PGEDx pins.

2.4 ICSP Pins

The PGECx and PGEDx pins are used for ICSP and debugging purposes. It is recommended to keep the trace length between the ICSP connector and the ICSP pins on the device as short as possible. If the ICSP connector is expected to experience an ESD event, a series resistor is recommended, with the value in the range of a few tens of Ohms, not to exceed 100 Ohms.

Pull-up resistors, series diodes and capacitors on the PGECx and PGEDx pins are not recommended as they will interfere with the programmer/debugger communications to the device. If such discrete components are an application requirement, they should be removed from the circuit during programming and debugging. Alternatively, refer to the AC/DC characteristics and timing requirements information in the respective device Flash programming specification for information on capacitive loading limits and pin input voltage high (V_{IH}) and input low (V_{IL}) requirements.

Ensure that the “Communication Channel Select” (i.e., PGECx/PGEDx pins) programmed into the device matches the physical connections for the ICSP to MPLAB[®] ICD 3 or MPLAB REAL ICE[™].

For more information on ICD 3 and REAL ICE connection requirements, refer to the following documents that are available from the Microchip web site.

- “Using MPLAB[®] ICD 3” (poster) (DS50001765)
- “MPLAB[®] ICD 3 Design Advisory” (DS50001764)
- “MPLAB[®] REAL ICE[™] In-Circuit Debugger User’s Guide” (DS50001616)
- “Using MPLAB[®] REAL ICE[™] Emulator” (poster) (DS50001749)

2.5 JTAG

The TMS, TDO, TDI and TCK pins are used for testing and debugging according to the Joint Test Action Group (JTAG) standard. It is recommended to keep the trace length between the JTAG connector and the JTAG pins on the device as short as possible. If the JTAG connector is expected to experience an ESD event, a series resistor is recommended, with the value in the range of a few tens of Ohms, not to exceed 100 Ohms.

Pull-up resistors, series diodes and capacitors on the TMS, TDO, TDI and TCK pins are not recommended as they will interfere with the programmer/debugger communications to the device. If such discrete components are an application requirement, they should be removed from the circuit during programming and debugging. Alternatively, refer to the AC/DC characteristics and timing requirements information in the respective device Flash programming specification for information on capacitive loading limits and pin input voltage high (V_{IH}) and input low (V_{IL}) requirements.

2.6 Trace

The trace pins can be connected to a hardware trace-enabled programmer to provide a compressed real-time instruction trace. When used for trace, the TRD3, TRD2, TRD1, TRD0 and TRCLK pins should be dedicated for this use. The trace hardware requires a 22 Ohm series resistor between the trace pins and the trace connector.

2.7 External Oscillator Pins

Many MCUs have options for at least two oscillators: a high-frequency primary oscillator and a low-frequency secondary oscillator (refer to [Section 8.0 “Oscillator Configuration”](#) for details).

The oscillator circuit should be placed on the same side of the board as the device. Also, place the oscillator circuit close to the respective oscillator pins, not exceeding one-half inch (12 mm) distance between them. The load capacitors should be placed next to the oscillator itself, on the same side of the board. Use a grounded copper pour around the oscillator circuit to isolate them from surrounding circuits. The grounded copper pour should be routed directly to the MCU ground. Do not run any signal traces or power traces inside the ground pour. Also, if using a two-sided board, avoid any traces on the other side of the board where the crystal is placed. A suggested layout is illustrated in [Figure 2-3](#).

FIGURE 2-3: SUGGESTED OSCILLATOR CIRCUIT PLACEMENT

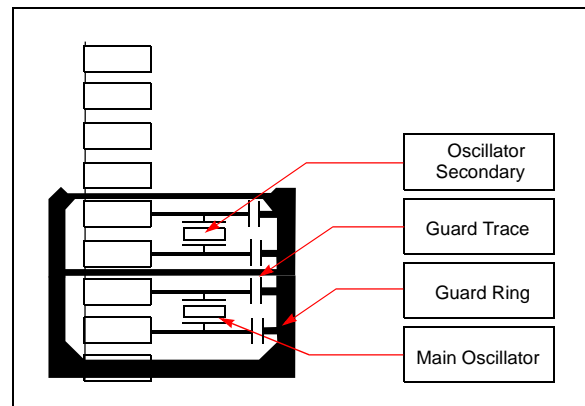

2.8 Unused I/Os

Unused I/O pins should not be allowed to float as inputs. They can be configured as outputs and driven to a logic-low state.

Alternatively, inputs can be reserved by connecting the pin to V_{SS} through a 1k to 10k resistor and configuring the pin as an input.

PIC32MZ Embedded Connectivity with Floating Point Unit (EF) Family

2.9 Designing for High-Speed Peripherals

The PIC32MZ EF family devices have peripherals that operate at frequencies much higher than typical for an embedded environment. [Table 2-1](#) lists the peripherals that produce high-speed signals on their external pins:

TABLE 2-1: PERIPHERALS THAT PRODUCE HS SIGNALS ON EXTERNAL PINS

| Peripheral | High-Speed Signal Pins | Maximum Speed on Signal Pin |
|------------|------------------------|-----------------------------|
| EBI | EBIAX, EBIDx | 50 MHz |
| SQI1 | SQICLK, SQICSx, SQIDx | 50 MHz |
| HS USB | D+, D- | 480 MHz |

Due to these high-speed signals, it is important to consider several factors when designing a product that uses these peripherals, as well as the PCB on which these components will be placed. Adhering to these recommendations will help achieve the following goals:

- Minimize the effects of electromagnetic interference to the proper operation of the product
- Ensure signals arrive at their intended destination at the same time
- Minimize crosstalk
- Maintain signal integrity
- Reduce system noise
- Minimize ground bounce and power sag

2.9.1 SYSTEM DESIGN

2.9.1.1 Impedance Matching

When selecting parts to place on high-speed buses, particularly the SQI bus, if the impedance of the peripheral device does not match the impedance of the pins on the PIC32MZ EF device to which it is connected, signal reflections could result, thereby degrading the quality of the signal.

If it is not possible to select a product that matches impedance, place a series resistor at the load to create the matching impedance. See [Figure 2-4](#) for an example.

FIGURE 2-4: SERIES RESISTOR

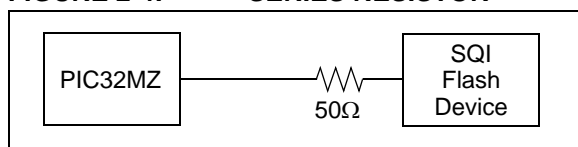

2.9.1.2 PCB Layout Recommendations

The following list contains recommendations that will help ensure the PCB layout will promote the goals previously listed.

- **Component Placement**
 - Place bypass capacitors as close to their component power and ground pins as possible, and place them on the same side of the PCB
 - Devices on the same bus that have larger setup times should be placed closer to the PIC32MZ EF device
- **Power and Ground**
 - Multi-layer PCBs will allow separate power and ground planes
 - Each ground pin should be connected to the ground plane individually
 - Place bypass capacitor vias as close to the pad as possible (preferably inside the pad)
 - If power and ground planes are not used, maximize width for power and ground traces
 - Use low-ESR, surface-mount bypass capacitors
- **Clocks and Oscillators**
 - Place crystals as close as possible to the PIC32MZ EF device OSC/SOSC pins
 - Do not route high-speed signals near the clock or oscillator
 - Avoid via usage and branches in clock lines (SQICLK)
 - Place termination resistors at the end of clock lines
- **Traces**
 - Higher-priority signals should have the shortest traces
 - Match trace lengths for parallel buses (EBIAX, EBIDx, SQIDx)
 - Avoid long run lengths on parallel traces to reduce coupling
 - Make the clock traces as straight as possible
 - Use rounded turns rather than right-angle turns
 - Have traces on different layers intersect on right angles to minimize crosstalk
 - Maximize the distance between traces, preferably no less than three times the trace width
 - Power traces should be as short and as wide as possible
 - High-speed traces should be placed close to the ground plane

2.9.1.3 EMI Suppression Considerations

The use of LDO regulators is preferred to reduce overall system noise and provide a cleaner power source. However, when utilizing switching Buck/Boost regulators as the local power source for PIC32MZ EF devices, as well as in electrically noisy environments, users should evaluate the use of T-Filters (i.e., L-C-L) on the power pins, as shown in Figure 2-5. In addition to a more stable power source, use of this type of T-Filter can greatly reduce susceptibility to EMI sources and events.

FIGURE 2-5:

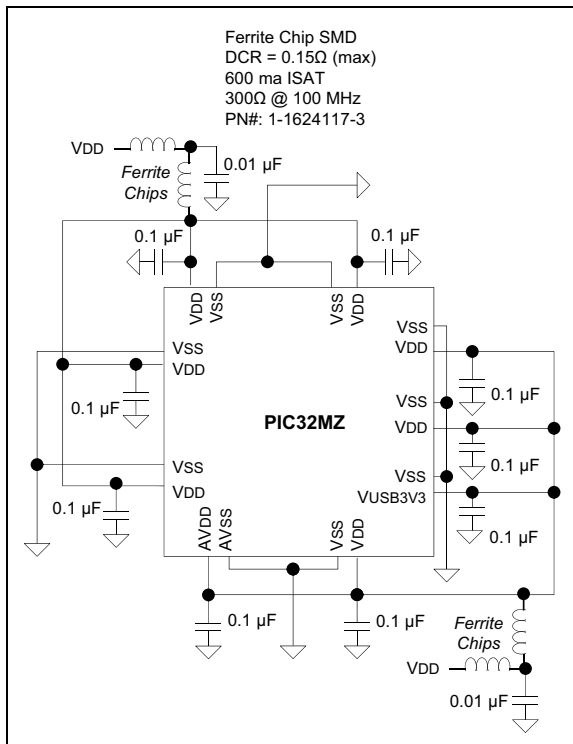

PIC32MZ Embedded Connectivity with Floating Point Unit (EF) Family

2.10 Typical Application Connection Examples

Examples of typical application connections are shown in [Figure 2-6](#) and [Figure 2-7](#).

FIGURE 2-6: AUDIO PLAYBACK APPLICATION

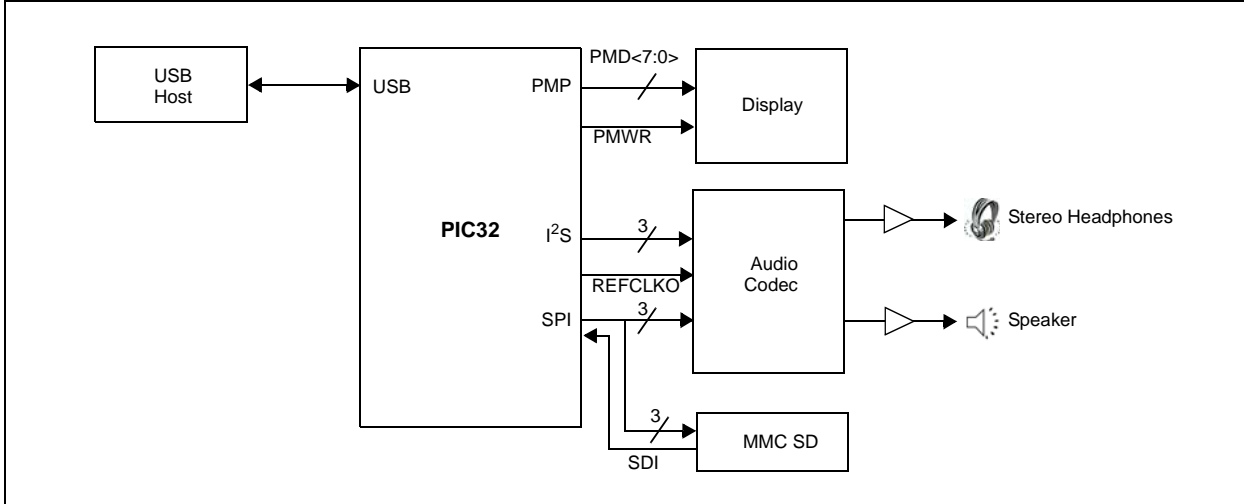
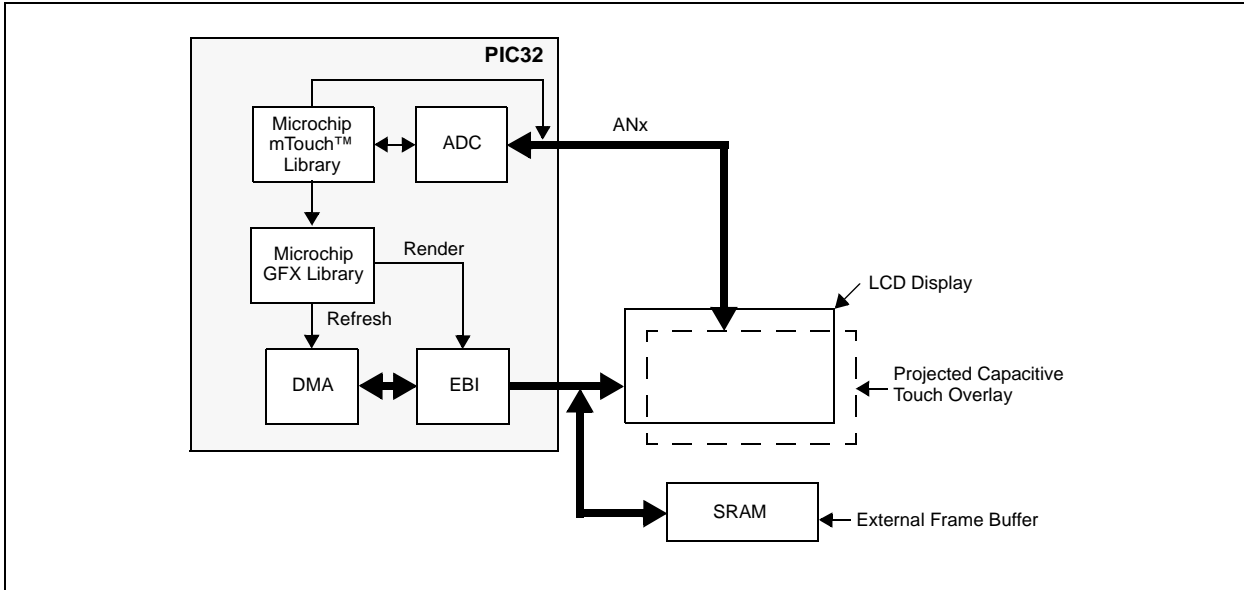

FIGURE 2-7: LOW-COST CONTROLLERLESS (LCC) GRAPHICS APPLICATION WITH PROJECTED CAPACITIVE TOUCH



3.0 CPU

Note 1: This data sheet summarizes the features of the PIC32MZ EF family of devices. It is not intended to be a comprehensive reference source. To complement the information in this data sheet, refer to **Section 50. “CPU for Devices with MIPS32[®] microAptiv[™] and M-Class Cores”** (DS60001192) of the *“PIC32 Family Reference Manual”*, which is available from the Microchip web site (www.microchip.com/PIC32).

2: The Series 5 Warrior M-class CPU core resources are available at: www.imgtec.com.

The MIPS32[®] M-Class Core is the heart of the PIC32MZ EF family device processor. The CPU fetches instructions, decodes each instruction, fetches source operands, executes each instruction and writes the results of instruction execution to the proper destinations.

Key features include:

- 5-stage pipeline
- 32-bit address and data paths
- MIPS32 Enhanced Architecture (Release 5):
 - Multiply-accumulate and multiply-subtract instructions
 - Targeted multiply instruction
 - Zero/One detect instructions
 - WAIT instruction
 - Conditional move instructions (MOVN, MOVZ)
 - Vectored interrupts
 - Programmable exception vector base
 - Atomic interrupt enable/disable
 - GPR shadow registers to minimize latency for interrupt handlers
 - Bit field manipulation instructions
 - Virtual memory support
- microMIPS[™] compatible instruction set:
 - Improves code size density over MIPS32, while maintaining MIPS32 performance.
 - Supports all MIPS32 instructions (except branch-likely instructions)
 - Fifteen additional 32-bit instructions and 39 16-bit instructions corresponding to commonly-used MIPS32 instructions
 - Stack pointer implicit in instruction
 - MIPS32 assembly and ABI compatible
- MMU with Translation Lookaside Buffer (TLB) mechanism:
 - 16 dual-entry fully associative Joint TLB
 - 4-entry fully associative Instruction and Data TLB
 - 4 KB pages
- Separate L1 data and instruction caches:
 - 16 KB 4-way Instruction Cache (I-Cache)
 - 4 KB 4-way Data Cache (D-Cache)
- Autonomous Multiply/Divide Unit (MDU):
 - Maximum issue rate of one 32x32 multiply per clock
 - Early-in iterative divide. Minimum 12 and maximum 38 clock latency (dividend (rs) sign extension-dependent)
- Power Control:
 - Minimum frequency: 0 MHz
 - Low-Power mode (triggered by WAIT instruction)
 - Extensive use of local gated clocks
- EJTAG Debug and Instruction Trace:
 - Support for single stepping
 - Virtual instruction and data address/value breakpoints
 - Hardware breakpoint supports both address match and address range triggering.
 - Eight instruction and four data complex breakpoints
- iFlowtrace[®] version 2.0 support:
 - Real-time instruction program counter
 - Special events trace capability
 - Two performance counters with 34 user-selectable countable events
 - Disabled if the processor enters Debug mode
 - Program Counter sampling
- Four Watch registers:
 - Instruction, Data Read, Data Write options
 - Address match masking options
- DSP ASE Extension:
 - Native fractional format data type operations
 - Register Single Instruction Multiple Data (SIMD) operations (add, subtract, multiply, shift)
 - GPR-based shift
 - Bit manipulation
 - Compare-Pick
 - DSP Control Access
 - Indexed-Load
 - Branch
 - Multiplication of complex operands
 - Variable bit insertion and extraction
 - Virtual circular buffers
 - Arithmetic saturation and overflow handling
 - Zero-cycle overhead saturation and rounding operations
- Floating Point Unit (FPU):
 - 1985 IEEE-754 compliant Floating Point Unit
 - Supports single and double precision datatypes
 - 2008 IEEE-754 compatibility control of NaN handling and Abs/Neg instructions
 - Runs at 1:1 core/FPU clock ratio

PIC32MZ Embedded Connectivity with Floating Point Unit (EF) Family

A block diagram of the PIC32MZ EF family processor core is shown in [Figure 3-1](#).

FIGURE 3-1: PIC32MZ EF FAMILY MICROPROCESSOR CORE BLOCK DIAGRAM

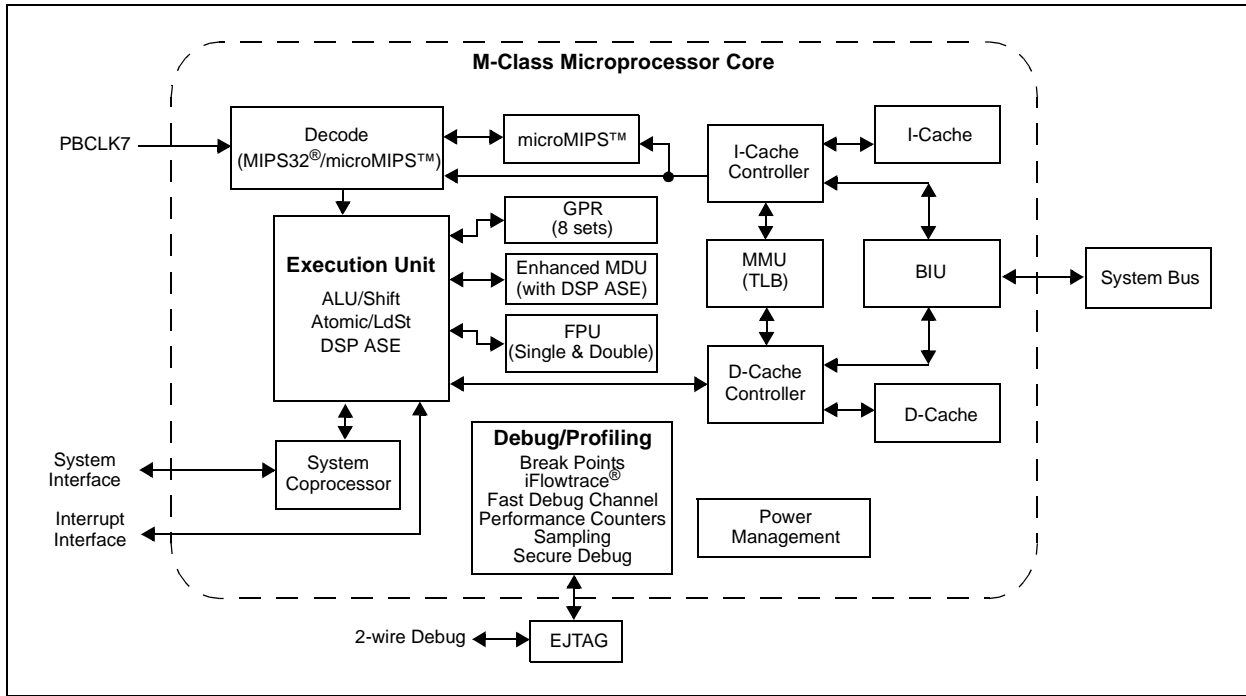

PIC32MZ Embedded Connectivity with Floating Point Unit (EF) Family

3.1 Architecture Overview

The MIPS32 M-Class Microprocessor core in PIC32MZ EF family devices contains several logic blocks working together in parallel, providing an efficient high-performance computing engine. The following blocks are included with the core:

- Execution unit
- General Purpose Register (GPR)
- Multiply/Divide Unit (MDU)
- System control coprocessor (CP0)
- Floating Point Unit (FPU)
- Memory Management Unit (MMU)
- Instruction/Data cache controllers
- Power Management
- Instructions and data caches
- microMIPS support
- Enhanced JTAG (EJTAG) controller

3.1.1 EXECUTION UNIT

The processor core execution unit implements a load/store architecture with single-cycle ALU operations (logical, shift, add, subtract) and an autonomous multiply/divide unit. The core contains thirty-two 32-bit General Purpose Registers (GPRs) used for integer operations and address calculation. Seven additional register file shadow sets (containing thirty-two registers) are added to minimize context switching overhead during interrupt/exception processing. The register file consists of two read ports and one write port and is fully bypassed to minimize operation latency in the pipeline.

The execution unit includes:

- 32-bit adder used for calculating the data address
- Address unit for calculating the next instruction address
- Logic for branch determination and branch target address calculation
- Load aligner
- Trap condition comparator
- Bypass multiplexers used to avoid stalls when executing instruction streams where data producing instructions are followed closely by consumers of their results

- Leading Zero/One detect unit for implementing the CLZ and CLO instructions
- Arithmetic Logic Unit (ALU) for performing arithmetic and bitwise logical operations
- Shifter and store aligner
- DSP ALU and logic block for performing DSP instructions, such as arithmetic/shift/compare operations

3.1.2 MULTIPLY/DIVIDE UNIT (MDU)

The processor core includes a Multiply/Divide Unit (MDU) that contains a separate pipeline for multiply and divide operations, and DSP ASE multiply instructions. This pipeline operates in parallel with the Integer Unit (IU) pipeline and does not stall when the IU pipeline stalls. This allows MDU operations to be partially masked by system stalls and/or other integer unit instructions.

The high-performance MDU consists of a 32x32 booth recoded multiplier, four pairs of result/accumulation registers (HI and LO), a divide state machine, and the necessary multiplexers and control logic. The first number shown ('32' of 32x32) represents the *rs* operand. The second number ('32' of 32x32) represents the *rt* operand.

The MDU supports execution of one multiply or multiply-accumulate operation every clock cycle.

Divide operations are implemented with a simple 1-bit-per-clock iterative algorithm. An early-in detection checks the sign extension of the dividend (*rs*) operand. If *rs* is 8 bits wide, 23 iterations are skipped. For a 16-bit wide *rs*, 15 iterations are skipped and for a 24-bit wide *rs*, 7 iterations are skipped. Any attempt to issue a subsequent MDU instruction while a divide is still active causes an IU pipeline stall until the divide operation has completed.

Table 3-1 lists the repeat rate (peak issue rate of cycles until the operation can be reissued) and latency (number of cycles until a result is available) for the processor core multiply and divide instructions. The approximate latency and repeat rates are listed in terms of pipeline clocks.

TABLE 3-1: MIPS32® M-CLASS MICROPROCESSOR CORE HIGH-PERFORMANCE INTEGER MULTIPLY/DIVIDE UNIT LATENCIES AND REPEAT RATES

| Opcode | Operand Size (mul <i>rt</i>) (div <i>rs</i>) | Latency | Repeat Rate |
|--|--|---------|-------------|
| MULT/MULTU, MADD/MADDU, MSUB/MSUBU (HI/LO destination) | 16 bits | 5 | 1 |
| | 32 bits | 5 | 1 |
| MUL (GPR destination) | 16 bits | 5 | 1 |
| | 32 bits | 5 | 1 |
| DIV/DIVU | 8 bits | 12/14 | 12/14 |
| | 16 bits | 20/22 | 20/22 |
| | 24 bits | 28/30 | 28/30 |
| | 32 bits | 36/38 | 36/38 |

PIC32MZ Embedded Connectivity with Floating Point Unit (EF) Family

The MIPS architecture defines that the result of a multiply or divide operation be placed in one of four pairs of HI and LO registers. Using the Move-From-HI (MFHI) and Move-From-LO (MFLO) instructions, these values can be transferred to the General Purpose Register file.

In addition to the HI/LO targeted operations, the MIPS32 architecture also defines a multiply instruction, MUL, which places the least significant results in the primary register file instead of the HI/LO register pair. By avoiding the explicit MFLO instruction required when using the LO register, and by supporting multiple destination registers, the throughput of multiply-intensive operations is increased.

Two other instructions, Multiply-Add (MADD) and Multiply-Subtract (MSUB), are used to perform the multiply-accumulate and multiply-subtract operations. The MADD instruction multiplies two numbers and then adds the product to the current contents of the HI and LO registers. Similarly, the MSUB instruction multiplies two operands and then subtracts the product from the HI and LO registers. The MADD and MSUB operations are commonly used in DSP algorithms.

The MDU also implements various shift instructions operating on the HI/LO register and multiply instructions as defined in the DSP ASE. The MDU supports all of the data types required for this purpose and includes three extra HI/LO registers as defined by the ASE.

Table 3-2 lists the latencies and repeat rates for the DSP multiply and dot-product operations. The approximate latencies and repeat rates are listed in terms of pipeline clocks.

TABLE 3-2: DSP-RELATED LATENCIES AND REPEAT RATES

| Op code | Latency | Repeat Rate |
|--|---------|-------------|
| Multiply and dot-product without saturation after accumulation | 5 | 1 |
| Multiply and dot-product with saturation after accumulation | 5 | 1 |
| Multiply without accumulation | 5 | 1 |

3.1.3 SYSTEM CONTROL COPROCESSOR (CP0)

In the MIPS architecture, CP0 is responsible for the virtual-to-physical address translation and cache protocols, the exception control system, the processor's diagnostics capability, the operating modes (Kernel, User and Debug) and whether interrupts are enabled or disabled. Configuration information, such as cache size and set associativity, and the presence of options like microMIPS is also available by accessing the CP0 registers, listed in Table 3-3.

TABLE 3-3: COPROCESSOR 0 REGISTERS

| Register Number | Register Name | Function |
|-----------------|------------------------|--|
| 0 | Index | Index into the TLB array (MPU only). |
| 1 | Random | Randomly generated index into the TLB array (MPU only). |
| 2 | EntryLo0 | Low-order portion of the TLB entry for even-numbered virtual pages (MPU only). |
| 3 | EntryLo1 | Low-order portion of the TLB entry for odd-numbered virtual pages (MPU only). |
| 4 | Context/ UserLocal | Pointer to the page table entry in memory (MPU only). User information that can be written by privileged software and read via the RDHWR instruction. |
| 5 | PageMask/ PageGrain | PageMask controls the variable page sizes in TLB entries. PageGrain enables support of 1 KB pages in the TLB (MPU only). |
| 6 | Wired | Controls the number of fixed (i.e., wired) TLB entries (MPU only). |
| 7 | HWREna | Enables access via the RDHWR instruction to selected hardware registers in Non-privileged mode. |
| 8 | BadVAddr | Reports the address for the most recent address-related exception. |
| | BadInstr | Reports the instruction that caused the most recent exception. |
| | BadInstrP | Reports the branch instruction if a delay slot caused the most recent exception. |
| 9 | Count | Processor cycle count. |
| 10 | EntryHi | High-order portion of the TLB entry (MPU only). |
| 11 | Compare | Core timer interrupt control. |

PIC32MZ Embedded Connectivity with Floating Point Unit (EF) Family

TABLE 3-3: COPROCESSOR 0 REGISTERS (CONTINUED)

| Register Number | Register Name | Function |
|-----------------|----------------|---|
| 12 | Status | Processor status and control. |
| | IntCtl | Interrupt control of vector spacing. |
| | SRSCtl | Shadow register set control. |
| | SRSMap | Shadow register mapping control. |
| | View_IPL | Allows the Priority Level to be read/written without extracting or inserting that bit from/to the Status register. |
| | SRSMAP2 | Contains two 4-bit fields that provide the mapping from a vector number to the shadow set number to use when servicing such an interrupt. |
| 13 | Cause | Describes the cause of the last exception. |
| | NestedExc | Contains the error and exception level status bit values that existed prior to the current exception. |
| | View_RIPL | Enables read access to the RIPL bit that is available in the Cause register. |
| 14 | EPC | Program counter at last exception. |
| | NestedEPC | Contains the exception program counter that existed prior to the current exception. |
| 15 | PRID | Processor identification and revision |
| | Ebase | Exception base address of exception vectors. |
| | CDMMBase | Common device memory map base. |
| 16 | Config | Configuration register. |
| | Config1 | Configuration register 1. |
| | Config2 | Configuration register 2. |
| | Config3 | Configuration register 3. |
| | Config4 | Configuration register 4. |
| | Config5 | Configuration register 5. |
| | Config7 | Configuration register 7. |
| 17 | LLAddr | Load link address (MPU only). |
| 18 | WatchLo | Low-order watchpoint address (MPU only). |
| 19 | WatchHi | High-order watchpoint address (MPU only). |
| 20-22 | Reserved | Reserved in the PIC32 core. |
| 23 | Debug | EJTAG debug register. |
| | TraceControl | EJTAG trace control. |
| | TraceControl2 | EJTAG trace control 2. |
| | UserTraceData1 | EJTAG user trace data 1 register. |
| | TraceBPC | EJTAG trace breakpoint register. |
| | Debug2 | Debug control/exception status 1. |
| 24 | DEPC | Program counter at last debug exception. |
| | UserTraceData2 | EJTAG user trace data 2 register. |
| 25 | PerfCtl0 | Performance counter 0 control. |
| | PerfCnt0 | Performance counter 0. |
| | PerfCtl1 | Performance counter 1 control. |
| | PerfCnt1 | Performance counter 1. |
| 26 | ErrCtl | Software test enable of way-select and data RAM arrays for I-Cache and D-Cache (MPU only). |
| 27 | Reserved | Reserved in the PIC32 core. |
| 28 | TagLo/DataLo | Low-order portion of cache tag interface (MPU only). |
| 29 | Reserved | Reserved in the PIC32 core. |
| 30 | ErrorEPC | Program counter at last error exception. |
| 31 | DeSave | Debug exception save. |

PIC32MZ Embedded Connectivity with Floating Point Unit (EF) Family

3.1.4 FLOATING POINT UNIT (FPU)

The Floating Point Unit (FPU), Coprocessor (CP1), implements the MIPS Instruction Set Architecture for floating point computation. The implementation supports the ANSI/IEEE Standard 754 (IEEE for Binary Floating Point Arithmetic) for single- and double-precision data formats. The FPU can be programmed to have thirty-two 32-bit or 64-bit floating point registers used for floating point operations.

The performance is optimized for single precision formats. Most instructions have one FPU cycle throughput and four FPU cycle latency. The FPU implements the multiply-add (MADD) and multiply-sub (MSUB) instructions with intermediate rounding after the multiply function. The result is guaranteed to be the same as executing a MUL and an ADD instruction separately, but the instruction latency, instruction fetch, dispatch bandwidth, and the total number of register accesses are improved.

IEEE denormalized input operands and results are supported by hardware for some instructions. IEEE denormalized results are not supported by hardware in general, but a fast flush-to-zero mode is provided to optimize performance. The fast flush-to-zero mode is enabled through the FCCR register, and use of this mode is recommended for best performance when denormalized results are generated.

The FPU has a separate pipeline for floating point instruction execution. This pipeline operates in parallel with the integer core pipeline and does not stall when the integer pipeline stalls. This allows long-running FPU operations, such as divide or square root, to be partially masked by system stalls and/or other integer unit instructions. Arithmetic instructions are always dispatched and completed in order, but loads and stores can complete out of order. The exception model is “precise” at all times.

Table 3-4 contains the floating point instruction latencies and repeat rates for the processor core. In this table, 'Latency' refers to the number of FPU cycles necessary for the first instruction to produce the result needed by the second instruction. The “Repeat Rate” refers to the maximum rate at which an instruction can be executed per FPU cycle.

TABLE 3-4: FPU INSTRUCTION LATENCIES AND REPEAT RATES

| Op code | Latency (FPU Cycles) | Repeat Rate (FPU Cycles) |
|--|----------------------|--------------------------|
| ABS.[S,D], NEG.[S,D], ADD.[S,D], SUB.[S,D], C.cond.[S,D], MUL.S | 4 | 1 |
| MADD.S, MSUB.S, NMADD.S, NMSUB.S, CABS.cond.[S,D] | 4 | 1 |
| CVT.D.S, CVT.PS.PW, CVT.[S,D].[W,L] | 4 | 1 |
| CVT.S.D, CVT.[W,L].[S,D], CEIL.[W,L].[S,D], FLOOR.[W,L].[S,D], ROUND.[W,L].[S,D], TRUNC.[W,L].[S,D] | 4 | 1 |
| MOV.[S,D], MOVF.[S,D], MOVN.[S,D], MOVT.[S,D], MOVZ.[S,D] | 4 | 1 |
| MUL.D | 5 | 2 |
| MADD.D, MSUB.D, NMADD.D, NMSUB.D | 5 | 2 |
| RECIP.S | 13 | 10 |
| RECIP.D | 26 | 21 |
| RSQRT.S | 17 | 14 |
| RSQRT.D | 36 | 31 |
| DIV.S, SQRT.S | 17 | 14 |
| DIV.D, SQRT.D | 32 | 29 |
| MTC1, DMTC1, LWC1, LDC1, LDXC1, LUXC1, LWXC1 | 4 | 1 |
| MFC1, DMFC1, SWC1, SDC1, SDXC1, SUXC1, SWXC1 | 1 | 1 |

Legend: S = Single D = Double
 W = Word L = Long word

The FPU implements a high-performance 7-stage pipeline:

- Decode, register read and unpack (FR stage)
- Multiply tree - double pumped for double (M1 stage)
- Multiply complete (M2 stage)
- Addition first step (A1 stage)
- Addition second and final step (A2 stage)
- Packing to IEEE format (FP stage)
- Register writeback (FW stage)

The FPU implements a bypass mechanism that allows the result of an operation to be forwarded directly to the instruction that needs it without having to write the result to the FPU register and then read it back.

Table 3-5 lists the Coprocessor 1 Registers for the FPU.

TABLE 3-5: FPU (CP1) REGISTERS

| Register Number | Register Name | Function |
|-----------------|---------------|---|
| 0 | FIR | Floating Point implementation register. Contains information that identifies the FPU. |
| 25 | FCCR | Floating Point condition codes register. |
| 26 | FEXR | Floating Point exceptions register. |
| 28 | FENR | Floating Point enables register. |
| 31 | FCSR | Floating Point Control and Status register. |

3.2 Power Management

The processor core offers a number of power management features, including low-power design, active power management and power-down modes of operation. The core is a static design that supports slowing or halting the clocks, which reduces system power consumption during Idle periods.

3.2.1 INSTRUCTION-CONTROLLED POWER MANAGEMENT

The mechanism for invoking Power-Down mode is through execution of the `WAIT` instruction. For more information on power management, see [Section 33.0 “Power-Saving Features”](#).

3.2.2 LOCAL CLOCK GATING

The majority of the power consumed by the processor core is in the clock tree and clocking registers. The PIC32MZ family makes extensive use of local gated-clocks to reduce this dynamic power consumption.

3.3 L1 Instruction and Data Caches

3.3.1 INSTRUCTION CACHE (I-CACHE)

The I-Cache is an on-core memory block of 16 Kbytes. Because the I-Cache is virtually indexed, the virtual-to-physical address translation occurs in parallel with the cache access rather than having to wait for the physical address translation. The tag holds 22 bits of physical address, a valid bit, and a lock bit. The LRU replacement bits are stored in a separate array.

The I-Cache block also contains and manages the instruction line fill buffer. Besides accumulating data to be written to the cache, instruction fetches that reference data in the line fill buffer are serviced either by a bypass of that data, or data coming from the external interface. The I-Cache control logic controls the bypass function.

The processor core supports I-Cache locking. Cache locking allows critical code or data segments to be locked into the cache on a per-line basis, enabling the system programmer to maximize the efficiency of the system cache.

The cache locking function is always available on all I-Cache entries. Entries can then be marked as locked or unlocked on a per entry basis using the `CACHE` instruction.

3.3.2 DATA CACHE (D-CACHE)

The D-Cache is an on-core memory block of 4 Kbytes. This virtually indexed, physically tagged cache is protected. Because the D-Cache is virtually indexed, the virtual-to-physical address translation occurs in parallel with the cache access. The tag holds 22 bits of physical address, a valid bit, and a lock bit. There is an additional array holding dirty bits and LRU replacement algorithm bits for each set of the cache.

In addition to I-Cache locking, the processor core also supports a D-Cache locking mechanism identical to the I-Cache. Critical data segments are locked into the cache on a per-line basis. The locked contents can be updated on a store hit, but cannot be selected for replacement on a cache miss.

The D-Cache locking function is always available on all D-Cache entries. Entries can then be marked as locked or unlocked on a per-entry basis using the `CACHE` instruction.

3.3.3 ATTRIBUTES

The processor core I-Cache and D-Cache attributes are listed in the Configuration registers (see [Register 3-1](#) through [Register 3-4](#)).

3.4 EJTAG Debug Support

The processor core provides for an Enhanced JTAG (EJTAG) interface for use in the software debug of application and kernel code. In addition to standard User mode and Kernel modes of operation, the processor core provides a Debug mode that is entered after a debug exception (derived from a hardware breakpoint, single-step exception, etc.) is taken and continues until a Debug Exception Return (DERET) instruction is executed. During this time, the processor executes the debug exception handler routine.

The EJTAG interface operates through the Test Access Port (TAP), a serial communication port used for transferring test data in and out of the core. In addition to the standard JTAG instructions, special instructions defined in the EJTAG specification specify which registers are selected and how they are used.

3.5 MIPS DSP ASE Extension

The MIPS DSP Application-Specific Extension Revision 2 is an extension to the MIPS32 architecture. This extension comprises new integer instructions and states that include new HI/LO accumulator register pairs and a DSP control register. This extension is crucial in a wide range of DSP, multimedia, and DSP-like algorithms covering Audio and Video processing applications. The extension supports native fractional format data type operations, register Single Instruction Multiple Data (SIMD) operations, such as add, subtract, multiply, and shift. In addition, the extension includes the following features that are essential in making DSP algorithms computationally efficient:

- Support for multiplication of complex operands
- Variable bit insertion and extraction
- Implementation and use of virtual circular buffers
- Arithmetic saturation and overflow handling support
- Zero cycle overhead saturation and rounding operations

3.6 microMIPS ISA

The processor core supports the microMIPS ISA, which contains all MIPS32 ISA instructions (except for branch-likely instructions) in a new 32-bit encoding scheme, with some of the commonly used instructions also available in 16-bit encoded format. This ISA improves code density through the additional 16-bit instructions while maintaining a performance similar to MIPS32 mode. In microMIPS mode, 16-bit or 32-bit instructions will be fetched and recoded to legacy MIPS32 instruction opcodes in the pipeline's I stage, so that the processor core can have the same microAptiv UP microarchitecture. Because the microMIPS instruction stream can be intermixed with 16-bit halfword or 32-bit word size instructions on halfword or word boundaries, additional logic is in place to address the word misalignment issues, thus minimizing performance loss.

PIC32MZ Embedded Connectivity with Floating Point Unit (EF) Family

3.7 M-Class Core Configuration

Register 3-1 through Register 3-4 show the default configuration of the M-Class core, which is included on PIC32MZ EF family devices.

REGISTER 3-1: CONFIG: CONFIGURATION REGISTER; CP0 REGISTER 16, SELECT 0

| Bit Range | Bit 31/23/15/7 | Bit 30/22/14/6 | Bit 29/21/13/5 | Bit 28/20/12/4 | Bit 27/19/11/3 | Bit 26/18/10/2 | Bit 25/17/9/1 | Bit 24/16/8/0 |
|-----------|----------------|----------------|----------------|----------------|----------------|----------------|---------------|---------------|
| 31:24 | r-1 | U-0 | U-0 | U-0 | U-0 | U-0 | U-0 | R-0 |
| | — | — | — | — | — | — | — | ISP |
| 23:16 | R-0 | R-0 | R-1 | R-0 | U-0 | R-1 | R-0 | R-0 |
| | DSP | UDI | SB | MDU | — | MM<1:0> | | BM |
| 15:8 | R-0 | R-0 | R-0 | R-0 | R-0 | R-1 | R-0 | R-0 |
| | BE | AT<1:0> | | AR<2:0> | | | MT<2:1> | |
| 7:0 | R-1 | U-0 | U-0 | U-0 | U-0 | R/W-0 | R/W-1 | R/W-0 |
| | MT<0> | — | — | — | — | K0<2:0> | | |

| | | |
|-------------------|------------------|------------------------------------|
| Legend: | r = Reserved bit | U = Unimplemented bit, read as '0' |
| R = Readable bit | W = Writable bit | '0' = Bit is cleared |
| -n = Value at POR | '1' = Bit is set | x = Bit is unknown |

- bit 31 **Reserved:** This bit is hardwired to '1' to indicate the presence of the Config1 register.
- bit 30-25 **Unimplemented:** Read as '0'
- bit 24 **ISP:** Instruction Scratch Pad RAM bit
0 = Instruction Scratch Pad RAM is not implemented
- bit 23 **DSP:** Data Scratch Pad RAM bit
0 = Data Scratch Pad RAM is not implemented
- bit 22 **UDI:** User-defined bit
0 = CorExtend User-Defined Instructions are not implemented
- bit 21 **SB:** SimpleBE bit
1 = Only Simple Byte Enables are allowed on the internal bus interface
- bit 20 **MDU:** Multiply/Divide Unit bit
0 = Fast, high-performance MDU
- bit 19 **Unimplemented:** Read as '0'
- bit 18-17 **MM<1:0>:** Merge Mode bits
10 = Merging is allowed
- bit 16 **BM:** Burst Mode bit
0 = Burst order is sequential
- bit 15 **BE:** Endian Mode bit
0 = Little-endian
- bit 14-13 **AT<1:0>:** Architecture Type bits
00 = MIPS32
- bit 12-10 **AR<2:0>:** Architecture Revision Level bits
001 = MIPS32 Release 2
- bit 9-7 **MT<2:0>:** MMU Type bits
001 = M-Class MPU Microprocessor core uses a TLB-based MMU
- bit 6-3 **Unimplemented:** Read as '0'
- bit 2-0 **K0<2:0>:** Kseg0 Coherency Algorithm bits
011 = Cacheable, non-coherent, write-back, write allocate
010 = Uncached
001 = Cacheable, non-coherent, write-through, write allocate
000 = Cacheable, non-coherent, write-through, no write allocate
All other values are not used and mapped to other values. 100, 101, and 110 are mapped to 010. 111 is mapped to 010.

PIC32MZ Embedded Connectivity with Floating Point Unit (EF) Family

REGISTER 3-2: CONFIG1: CONFIGURATION REGISTER 1; CP0 REGISTER 16, SELECT 1

| Bit Range | Bit 31/23/15/7 | Bit 30/22/14/6 | Bit 29/21/13/5 | Bit 28/20/12/4 | Bit 27/19/11/3 | Bit 26/18/10/2 | Bit 25/17/9/1 | Bit 24/16/8/0 |
|-----------|----------------|----------------|----------------|----------------|----------------|----------------|---------------|---------------|
| 31:24 | r-1 — | R-0 | R-0 | R-1 | R-1 | R-1 | R-1 | R-0 |
| | MMU Size<5:0> | | | | | | | IS<2> |
| 23:16 | R-1 | R-0 | R-0 | R-1 | R-1 | R-0 | R-1 | R-1 |
| | IS<1:0> | | IL<2:0> | | | IA<2:0> | | |
| 15:8 | R-0 | R-0 | R-0 | R-0 | R-1 | R-1 | R-0 | R-1 |
| | DS<2:0> | | | DL<2:0> | | DA<2:1> | | |
| 7:0 | R-1 | U-0 | U-0 | R-1 | R-1 | R-0 | R-1 | R-1 |
| | DA<0> | — | — | PC | WR | CA | EP | FP |

| | |
|-------------------|------------------------------------|
| Legend: | r = Reserved bit |
| R = Readable bit | W = Writable bit |
| -n = Value at POR | U = Unimplemented bit, read as '0' |
| | '1' = Bit is set |
| | '0' = Bit is cleared |
| | x = Bit is unknown |

bit 31 **Reserved:** This bit is hardwired to a '1' to indicate the presence of the Config2 register.

bit 30-25 **MMU Size<5:0>:** Contains the number of TLB entries minus 1

001111 = 16 TLB entries

bit 24-22 **IS<2:0>:** Instruction Cache Sets bits

010 = Contains 256 instruction cache sets per way

bit 21-19 **IL<2:0>:** Instruction-Cache Line bits

011 = Contains instruction cache line size of 16 bytes

bit 18-16 **IA<2:0>:** Instruction-Cache Associativity bits

011 = Contains 4-way instruction cache associativity

bit 15-13 **DS<2:0>:** Data-Cache Sets bits

000 = Contains 64 data cache sets per way

bit 12-10 **DL<2:0>:** Data-Cache Line bits

011 = Contains data cache line size of 16 bytes

bit 9-7 **DA<2:0>:** Data-Cache Associativity bits

011 = Contains the 4-way set associativity for the data cache

bit 6-5 **Unimplemented:** Read as '0'

bit 4 **PC:** Performance Counter bit

1 = The processor core contains Performance Counters

bit 3 **WR:** Watch Register Presence bit

1 = No Watch registers are present

bit 2 **CA:** Code Compression Implemented bit

0 = No MIPS16e[®] present

bit 1 **EP:** EJTAG Present bit

1 = Core implements EJTAG

bit 0 **FP:** Floating Point Unit bit

1 = Floating Point Unit is present

PIC32MZ Embedded Connectivity with Floating Point Unit (EF) Family

REGISTER 3-3: CONFIG3: CONFIGURATION REGISTER 3; CP0 REGISTER 16, SELECT 3

| Bit Range | Bit 31/23/15/7 | Bit 30/22/14/6 | Bit 29/21/13/5 | Bit 28/20/12/4 | Bit 27/19/11/3 | Bit 26/18/10/2 | Bit 25/17/9/1 | Bit 24/16/8/0 |
|-----------|--------------------------------|------------------|----------------|----------------|----------------|----------------|---------------|----------------------------------|
| 31:24 | r-1 — | U-0 — | U-0 — | U-0 — | U-0 — | U-0 — | U-0 — | U-0 — |
| 23:16 | U-0 — | R-0 IPLW<1:0> | R-1 | R-0 | R-0 | R-0 | R-1 MCU | R/W-y ISAONEXC ⁽¹⁾ |
| 15:8 | R-y ISA<1:0> ⁽¹⁾ | R-y | R-1 ULRI | R-1 RXI | R-1 DSP2P | R-1 DSPP | U-0 — | R-1 ITL |
| 7:0 | U-0 — | R-1 VEIC | R-1 VINT | R-0 SP | R-1 CDMM | U-0 — | U-0 — | R-0 TL |

| | | |
|-------------------|------------------|--|
| Legend: | r = Reserved bit | y = Value set from Configuration bits on POR |
| R = Readable bit | W = Writable bit | U = Unimplemented bit, read as '0' |
| -n = Value at POR | '1' = Bit is set | '0' = Bit is cleared x = Bit is unknown |

- bit 31 **Reserved:** This bit is hardwired as '1' to indicate the presence of the Config4 register
- bit 30-23 **Unimplemented:** Read as '0'
- bit 22-21 **IPLW<1:0>:** Width of the Status IPL and Cause RIPL bits
01 = IPL and RIPL bits are 8-bits in width
- bit 20-18 **MMAR<2:0>:** microMIPS Architecture Revision Level bits
000 = Release 1
- bit 17 **MCU:** MIPS® MCU™ ASE Implemented bit
1 = MCU ASE is implemented
- bit 16 **ISAONEXC:** ISA on Exception bit⁽¹⁾
1 = microMIPS is used on entrance to an exception vector
0 = MIPS32 ISA is used on entrance to an exception vector
- bit 15-14 **ISA<1:0>:** Instruction Set Availability bits⁽¹⁾
11 = Both MIPS32 and microMIPS are implemented; microMIPS is used when coming out of reset
10 = Both MIPS32 and microMIPS are implemented; MIPS32 ISA used when coming out of reset
- bit 13 **ULRI:** UserLocal Register Implemented bit
1 = UserLocal Coprocessor 0 register is implemented
- bit 12 **RXI:** RIE and XIE Implemented in PageGrain bit
1 = RIE and XIE bits are implemented
- bit 11 **DSP2P:** MIPS DSP ASE Revision 2 Presence bit
1 = DSP Revision 2 is present
- bit 10 **DSPP:** MIPS DSP ASE Presence bit
1 = DSP is present
- bit 9 **Unimplemented:** Read as '0'
- bit 8 **ITL:** Indicates that iFlowtrace® hardware is present
1 = The iFlowtrace® is implemented in the core
- bit 7 **Unimplemented:** Read as '0'
- bit 6 **VEIC:** External Vector Interrupt Controller bit
1 = Support for an external interrupt controller is implemented.
- bit 5 **VINT:** Vector Interrupt bit
1 = Vector interrupts are implemented
- bit 4 **SP:** Small Page bit
0 = 4 KB page size
- bit 3 **CDMM:** Common Device Memory Map bit
1 = CDMM is implemented
- bit 2-1 **Unimplemented:** Read as '0'
- bit 0 **TL:** Trace Logic bit
0 = Trace logic is not implemented

Note 1: These bits are set based on the value of the BOOTISA Configuration bit (DEVCFG0<6>).

PIC32MZ Embedded Connectivity with Floating Point Unit (EF) Family

REGISTER 3-4: CONFIG5: CONFIGURATION REGISTER 5; CP0 REGISTER 16, SELECT 5

| Bit Range | Bit 31/23/15/7 | Bit 30/22/14/6 | Bit 29/21/13/5 | Bit 28/20/12/4 | Bit 27/19/11/3 | Bit 26/18/10/2 | Bit 25/17/9/1 | Bit 24/16/8/0 |
|-----------|----------------|----------------|----------------|----------------|----------------|----------------|---------------|---------------|
| 31:24 | U-0 | U-0 | U-0 | U-0 | U-0 | U-0 | U-0 | U-0 |
| | — | — | — | — | — | — | — | — |
| 23:16 | U-0 | U-0 | U-0 | U-0 | U-0 | U-0 | U-0 | U-0 |
| | — | — | — | — | — | — | — | — |
| 15:8 | U-0 | U-0 | U-0 | U-0 | U-0 | U-0 | U-0 | U-0 |
| | — | — | — | — | — | — | — | — |
| 7:0 | U-0 | U-0 | U-0 | U-0 | U-0 | U-0 | U-0 | R-1 |
| | — | — | — | — | — | — | — | NF |

Legend:

r = Reserved
 R = Readable bit W = Writable bit U = Unimplemented bit, read as '0'
 -n = Value at POR '1' = Bit is set '0' = Bit is cleared x = Bit is unknown

bit 31-1 **Unimplemented:** Read as '0'
 bit 0 **NF:** Nested Fault bit
 1 = Nested Fault feature is implemented

REGISTER 3-5: CONFIG7: CONFIGURATION REGISTER 7; CP0 REGISTER 16, SELECT 7

| Bit Range | Bit 31/23/15/7 | Bit 30/22/14/6 | Bit 29/21/13/5 | Bit 28/20/12/4 | Bit 27/19/11/3 | Bit 26/18/10/2 | Bit 25/17/9/1 | Bit 24/16/8/0 |
|-----------|----------------|----------------|----------------|----------------|----------------|----------------|---------------|---------------|
| 31:24 | R-1 | U-0 | U-0 | U-0 | U-0 | U-0 | U-0 | U-0 |
| | W1 | — | — | — | — | — | — | — |
| 23:16 | U-0 | U-0 | U-0 | U-0 | U-0 | U-0 | U-0 | U-0 |
| | — | — | — | — | — | — | — | — |
| 15:8 | U-0 | U-0 | U-0 | U-0 | U-0 | U-0 | U-0 | U-0 |
| | — | — | — | — | — | — | — | — |
| 7:0 | U-0 | U-0 | U-0 | U-0 | U-0 | U-0 | U-0 | U-0 |
| | — | — | — | — | — | — | — | — |

Legend:

R = Readable bit W = Writable bit U = Unimplemented bit, read as '0'
 -n = Value at POR '1' = Bit is set '0' = Bit is cleared x = Bit is unknown

bit 31 **W1:** Wait IE Ignore bit
 1 = Indicates that this processor will allow an interrupt to unblock a WAIT instruction
 bit 30-0 **Unimplemented:** Read as '0'

PIC32MZ Embedded Connectivity with Floating Point Unit (EF) Family

REGISTER 3-6: FIR: FLOATING POINT IMPLEMENTATION REGISTER; CP1 REGISTER 0

| Bit Range | Bit 31/23/15/7 | Bit 30/22/14/6 | Bit 29/21/13/5 | Bit 28/20/12/4 | Bit 27/19/11/3 | Bit 26/18/10/2 | Bit 25/17/9/1 | Bit 24/16/8/0 |
|-----------|----------------|----------------|----------------|----------------|----------------|----------------|---------------|---------------|
| 31:24 | U-0 | U-0 | U-0 | R-1 | U-0 | U-0 | U-0 | R-1 |
| | — | — | — | UFRP | — | — | — | FC |
| 23:16 | R-1 | R-1 | R-1 | R-1 | R-0 | R-0 | R-1 | R-1 |
| | HAS2008 | F64 | L | W | MIPS3D | PS | D | S |
| 15:8 | R-1 | R-0 | R-1 | R-0 | R-0 | R-1 | R-1 | R-1 |
| | PRID<7:0> | | | | | | | |
| 7:0 | R-x | R-x | R-x | R-x | R-x | R-x | R-x | R-x |
| | REVISION<7:0> | | | | | | | |

Legend:

R = Readable bit
-n = Value at POR

W = Writable bit
'1' = Bit is set

U = Unimplemented bit, read as '0'
'0' = Bit is cleared
x = Bit is unknown

bit 31-29 **Unimplemented:** Read as '0'

bit 28 **UFRP:** User Mode FR Switching Instruction bit
1 = User mode FR switching instructions are supported
0 = User mode FR switching instructions are not supported

bit 27-25 **Unimplemented:** Read as '0'

bit 24 **FC:** Full Convert Ranges bit
1 = Full convert ranges are implemented (all numbers can be converted to another type by the FPU)
0 = Full convert ranges are not implemented

bit 23 **HAS008:** IEEE-754-2008 bit
1 = MAC2008, ABS2008, NAN2008 bits exist within the FCSR register
0 = MAC2009, ABS2008, and NAN2008 bits do not exist within the FCSR register

bit 22 **F64:** 64-bit FPU bit
1 = This is a 64-bit FPU
0 = This is not a 64-bit FPU

bit 21 **L:** Long Fixed Point Data Type bit
1 = Long fixed point data types are implemented
0 = Long fixed point data types are not implemented

bit 20 **W:** Word Fixed Point data type bit
1 = Word fixed point data types are implemented
0 = Word fixed point data types are not implemented

bit 19 **MIPS3D:** MIPS-3D ASE bit
1 = MIPS-3D is implemented
0 = MIPS-3D is not implemented

bit 18 **PS:** Paired Single Floating Point data bit
1 = PS floating point is implemented
0 = PS floating point is not implemented

bit 17 **D:** Double-precision floating point data bit
1 = Double-precision floating point data types are implemented
0 = Double-precision floating point data types are not implemented

bit 16 **S:** Single-precision Floating Point Data bit
1 = Single-precision floating point data types are implemented
0 = Single-precision floating point data types are not implemented

bit 15-8 **PRID<7:0>:** Processor Identification bits
These bits allow software to distinguish between the various types of MIPS processors. For PIC32 devices with the M-Class core, this value is 0xA7.

bit 7-0 **REVISION<7:0>:** Processor Revision Identification bits
These bits allow software to distinguish between one revision and another of the same processor type. This number is increased on major revisions of the processor core

PIC32MZ Embedded Connectivity with Floating Point Unit (EF) Family

REGISTER 3-7: FCCR: FLOATING POINT CONDITION CODES REGISTER; CP1 REGISTER 25

| Bit Range | Bit 31/23/15/7 | Bit 30/22/14/6 | Bit 29/21/13/5 | Bit 28/20/12/4 | Bit 27/19/11/3 | Bit 26/18/10/2 | Bit 25/17/9/1 | Bit 24/16/8/0 |
|-----------|----------------|----------------|----------------|----------------|----------------|----------------|---------------|---------------|
| 31:24 | U-0 | U-0 | U-0 | U-0 | U-0 | U-0 | U-0 | U-0 |
| | — | — | — | — | — | — | — | — |
| 23:16 | U-0 | U-0 | U-0 | U-0 | U-0 | U-0 | U-0 | U-0 |
| | — | — | — | — | — | — | — | — |
| 15:8 | U-0 | U-0 | U-0 | U-0 | U-0 | U-0 | U-0 | U-0 |
| | — | — | — | — | — | — | — | — |
| 7:0 | R/W-x | R/W-x | R/W-x | R/W-x | R/W-x | R/W-x | R/W-x | R/W-x |
| | FCC<7:0> | | | | | | | |

Legend:

R = Readable bit

W = Writable bit

U = Unimplemented bit, read as '0'

-n = Value at POR

'1' = Bit is set

'0' = Bit is cleared

x = Bit is unknown

bit 31-8 **Unimplemented:** Read as '0'

bit 7-0 **FCC<7:0>:** Floating Point Condition Code bits

These bits record the results of floating point compares and are tested for floating point conditional branches and conditional moves.

PIC32MZ Embedded Connectivity with Floating Point Unit (EF) Family

REGISTER 3-8: FE XR: FLOATING POINT EXCEPTIONS STATUS REGISTER; CP1 REGISTER 26

| Bit Range | Bit 31/23/15/7 | Bit 30/22/14/6 | Bit 29/21/13/5 | Bit 28/20/12/4 | Bit 27/19/11/3 | Bit 26/18/10/2 | Bit 25/17/9/1 | Bit 24/16/8/0 |
|-----------|----------------|----------------|----------------|----------------|----------------|----------------|---------------|---------------|
| 31:24 | U-0 | U-0 | U-0 | U-0 | U-0 | U-0 | U-0 | U-0 |
| | — | — | — | — | — | — | — | — |
| 23:16 | U-0 | U-0 | U-0 | U-0 | U-0 | U-0 | R/W-x | R/W-x |
| | — | — | — | — | — | — | CAUSE<5:4> | |
| | | | | | | | E | V |
| 15:8 | R/W-x | R/W-x | R/W-x | U-0 | U-0 | U-0 | U-0 | U-0 |
| | CAUSE<3:0> | | | | — | — | — | — |
| | Z | O | U | I | | | | |
| 7:0 | U-0 | R/W-x | R/W-x | R/W-x | R/W-x | R/W-x | U-0 | U-0 |
| | — | FLAGS<4:0> | | | | | — | — |
| | | V | Z | O | U | I | | |

Legend:

R = Readable bit
-n = Value at POR

W = Writable bit
'1' = Bit is set

U = Unimplemented bit, read as '0'
'0' = Bit is cleared
x = Bit is unknown

bit 31-18 **Unimplemented:** Read as '0'

bit 17-12 **CAUSE<5:0>**: FPU Exception Cause bits

These bits indicated the exception conditions that arise during execution of an FPU arithmetic instruction.

bit 17 **E**: Unimplemented Operation bit

bit 16 **V**: Invalid Operation bit

bit 15 **Z**: Divide-by-Zero bit

bit 14 **O**: Overflow bit

bit 13 **U**: Underflow bit

bit 12 **I**: Inexact bit

bit 11-7 **Unimplemented:** Read as '0'

bit 6-2 **FLAGS<4:0>**: FPU Flags bits

These bits show any exception conditions that have occurred for completed instructions since the flag was last reset by software.

bit 6 **V**: Invalid Operation bit

bit 4 **Z**: Divide-by-Zero bit

bit 4 **O**: Overflow bit

bit 3 **U**: Underflow bit

bit 2 **I**: Inexact bit

bit 1-0 **Unimplemented:** Read as '0'

PIC32MZ Embedded Connectivity with Floating Point Unit (EF) Family

REGISTER 3-9: FENR: FLOATING POINT EXCEPTIONS AND MODES ENABLE REGISTER; CP1 REGISTER 28

| Bit Range | Bit 31/23/15/7 | Bit 30/22/14/6 | Bit 29/21/13/5 | Bit 28/20/12/4 | Bit 27/19/11/3 | Bit 26/18/10/2 | Bit 25/17/9/1 | Bit 24/16/8/0 |
|-----------|----------------|----------------|----------------|----------------|----------------|----------------|---------------|---------------|
| 31:24 | U-0 | U-0 | U-0 | U-0 | U-0 | U-0 | U-0 | U-0 |
| | — | — | — | — | — | — | — | — |
| 23:16 | U-0 | U-0 | U-0 | U-0 | U-0 | U-0 | U-0 | U-0 |
| | — | — | — | — | — | — | — | — |
| 15:8 | U-0 | U-0 | U-0 | U-0 | R/W-x | R/W-x | R/W-x | R/W-x |
| | — | — | — | — | ENABLES<4:1> | | | |
| | | | | | V | Z | O | U |
| 7:0 | R/W-x | U-0 | U-0 | U-0 | U-0 | R-x | R/W-x | R/W-x |
| | ENABLES<0> | — | — | — | — | FS | RM<1:0> | |
| | I | | | | | | | |

Legend:

R = Readable bit W = Writable bit U = Unimplemented bit, read as '0'
-n = Value at POR '1' = Bit is set '0' = Bit is cleared x = Bit is unknown

bit 31-12 **Unimplemented:** Read as '0'

bit 11-7 **ENABLES<4:0>:** FPU Exception Enable bits

These bits control whether or not a trap is taken when an IEEE exception condition occurs for any of the five conditions. The trap occurs when both an enable bit and its corresponding cause bit are set either during an FPU arithmetic operation or by moving a value to the FCSR or one of its alternative representations.

bit 11 **V:** Invalid Operation bit

bit 10 **Z:** Divide-by-Zero bit

bit 9 **O:** Overflow bit

bit 8 **U:** Underflow bit

bit 7 **I:** Inexact bit

bit 6-3 **Unimplemented:** Read as '0'

bit 2 **FS:** Flush to Zero control bit

1 = Denormal input operands are flushed to zero. Tiny results are flushed to either zero or the applied format's smallest normalized number (MinNorm) depending on the rounding mode settings.

0 = Denormal input operands result in an Unimplemented Operation exception.

bit 1-0 **RM<1:0>:** Rounding Mode control bits

11 = Round towards Minus Infinity ($-\infty$)

10 = Round towards Plus Infinity ($+\infty$)

01 = Round toward Zero (0)

00 = Round to Nearest

PIC32MZ Embedded Connectivity with Floating Point Unit (EF) Family

REGISTER 3-10: FCSR: FLOATING POINT CONTROL AND STATUS REGISTER; CP1 REGISTER 31

| Bit Range | Bit 31/23/15/7 | Bit 30/22/14/6 | Bit 29/21/13/5 | Bit 28/20/12/4 | Bit 27/19/11/3 | Bit 26/18/10/2 | Bit 25/17/9/1 | Bit 24/16/8/0 |
|-----------|----------------|----------------|----------------|----------------|----------------|----------------|---------------|---------------|
| 31:24 | R/W-x | R/W-x | R/W-x | R/W-x | R/W-x | R/W-x | R/W-x | R/W-x |
| | FCC<7:1> | | | | | | | FS |
| 23:16 | R/W-x | R/W-x | R/W-x | R-0 | R-1 | R-1 | R/W-x | R/W-x |
| | FCC<0> | FO | FN | MAC2008 | ABS2008 | NAN2008 | CAUSE<5:4> | |
| 15:8 | R/W-x | R/W-x | R/W-x | R/W-x | R/W-x | R/W-x | R/W-x | R/W-x |
| | CAUSE<3:0> | | | | ENABLES<4:1> | | | |
| | | | | | V | Z | O | U |
| 7:0 | R/W-x | R/W-x | R/W-x | R/W-x | R/W-x | R/W-x | R/W-x | R/W-x |
| | ENABLES<0> | FLAGS<4:0> | | | | | RM<1:0> | |
| | I | V | Z | O | U | I | | |

Legend:

R = Readable bit

W = Writable bit

U = Unimplemented bit, read as '0'

-n = Value at POR

'1' = Bit is set

'0' = Bit is cleared

x = Bit is unknown

bit 31-25 **FCC<7:1>**: Floating Point Condition Code bits

These bits record the results of floating point compares and are tested for floating point conditional branches and conditional moves.

bit 24 **FS**: Flush to Zero control bit

1 = Denormal input operands are flushed to zero. Tiny results are flushed to either zero or the applied format's smallest normalized number (MinNorm) depending on the rounding mode settings.

0 = Denormal input operands result in an Unimplemented Operation exception.

bit 23 **FCC<0>**: Floating Point Condition Code bits

These bits record the results of floating point compares and are tested for floating point conditional branches and conditional moves.

bit 22 **FO**: Flush Override Control bit

1 = The intermediate result is kept in an internal format, which can be perceived as having the usual mantissa precision but with unlimited exponent precision and without forcing to a specific value or taking an exception.

0 = Handling of Tiny Result values depends on setting of the FS bit.

bit 21 **FN**: Flush to Nearest Control bit

1 = Final result is rounded to either zero or 2E_min (MinNorm), whichever is closest when in Round to Nearest (RN) rounding mode. For other rounding modes, a final result is given as if FS was set to 1.

0 = Handling of Tiny Result values depends on setting of the FS bit.

bit 20 **MAC2008**: Fused Multiply Add mode control bit

0 = Unfused multiply-add. Intermediary multiplication results are rounded to the destination format.

bit 19 **ABS2008**: Absolute value format control bit

1 = ABS.fmt and NEG.fmt instructions compliant with IEEE Standard 754-2008. The ABS and NEG functions accept QNAN inputs without trapping.

bit 18 **NAN2008**: NaN Encoding control bit

1 = Quiet and signaling NaN encodings recommended by the IEEE Standard 754-2008. A quiet NaN is encoded with the first bit of the fraction being 1 and a signaling NaN is encoded with the first bit of the fraction being 0.

bit 17-12 **CAUSE<5:0>**: FPU Exception Cause bits

These bits indicated the exception conditions that arise during execution of an FPU arithmetic instruction.

bit 17 **E**: Unimplemented Operation bit

PIC32MZ Embedded Connectivity with Floating Point Unit (EF) Family

REGISTER 3-10: FCSR: FLOATING POINT CONTROL AND STATUS REGISTER; CP1 REGISTER 31

- bit 16 **V**: Invalid Operation bit
- bit 15 **Z**: Divide-by-Zero bit
- bit 14 **O**: Overflow bit
- bit 13 **U**: Underflow bit
- bit 12 **I**: Inexact bit
- bit 11-7 **ENABLES<4:0>**: FPU Exception Enable bits
These bits control whether or not a trap is taken when an IEEE exception condition occurs for any of the five conditions. The trap occurs when both an enable bit and its corresponding cause bit are set either during an FPU arithmetic operation or by moving a value to the FCSR or one of its alternative representations.
- bit 11 **V**: Invalid Operation bit
- bit 10 **Z**: Divide-by-Zero bit
- bit 9 **O**: Overflow bit
- bit 8 **U**: Underflow bit
- bit 7 **I**: Inexact bit
- bit 6-2 **FLAGS<4:0>**: FPU Flags bits
These bits show any exception conditions that have occurred for completed instructions since the flag was last reset by software.
- bit 6 **V**: Invalid Operation bit
- bit 5 **Z**: Divide-by-Zero bit
- bit 4 **O**: Overflow bit
- bit 3 **U**: Underflow bit
- bit 2 **I**: Inexact bit
- bit 1-0 **RM<1:0>**: Rounding Mode control bits
11 = Round towards Minus Infinity ($-\infty$)
10 = Round towards Plus Infinity ($+\infty$)
01 = Round toward Zero (0)
00 = Round to Nearest

4.0 MEMORY ORGANIZATION

Note: This data sheet summarizes the features of the PIC32MZ EF family of devices. It is not intended to be a comprehensive reference source. For detailed information, refer to **Section 48. “Memory Organization and Permissions”** in the “*PIC32 Family Reference Manual*”, which is available from the Microchip web site (www.microchip.com/PIC32).

PIC32MZ EF microcontrollers provide 4 GB of unified virtual memory address space. All memory regions, including program, data memory, SFRs and Configuration registers, reside in this address space at their respective unique addresses. The program and data memories can be optionally partitioned into user and kernel memories. In addition, PIC32MZ EF devices allow execution from data memory.

Key features include:

- 32-bit native data width
- Separate User (KUSEG) and Kernel (KSEG0/KSEG1/KSEG2/KSEG3) mode address space
- Separate boot Flash memory for protected code
- Robust bus exception handling to intercept runaway code
- Cacheable (KSEG0/KSEG2) and non-cacheable (KSEG1/KSEG3) address regions
- Read-Write permission access to predefined memory regions

4.1 Memory Layout

PIC32MZ EF microcontrollers implement two address schemes: virtual and physical. All hardware resources, such as program memory, data memory and peripherals, are located at their respective physical addresses. Virtual addresses are exclusively used by the CPU to fetch and execute instructions as well as access peripherals. Physical addresses are used by bus master peripherals, such as DMA and the Flash controller, that access memory independently of the CPU.

The main memory maps for the PIC32MZ EF devices are illustrated in [Figure 4-1](#) through [Figure 4-4](#). [Figure 4-5](#) provides memory map information for boot Flash and boot alias. [Table 4-1](#) provides memory map information for Special Function Registers (SFRs).

PIC32MZ Embedded Connectivity with Floating Point Unit (EF) Family

FIGURE 4-1: MEMORY MAP FOR DEVICES WITH 512 KB OF PROGRAM MEMORY^(1,2)

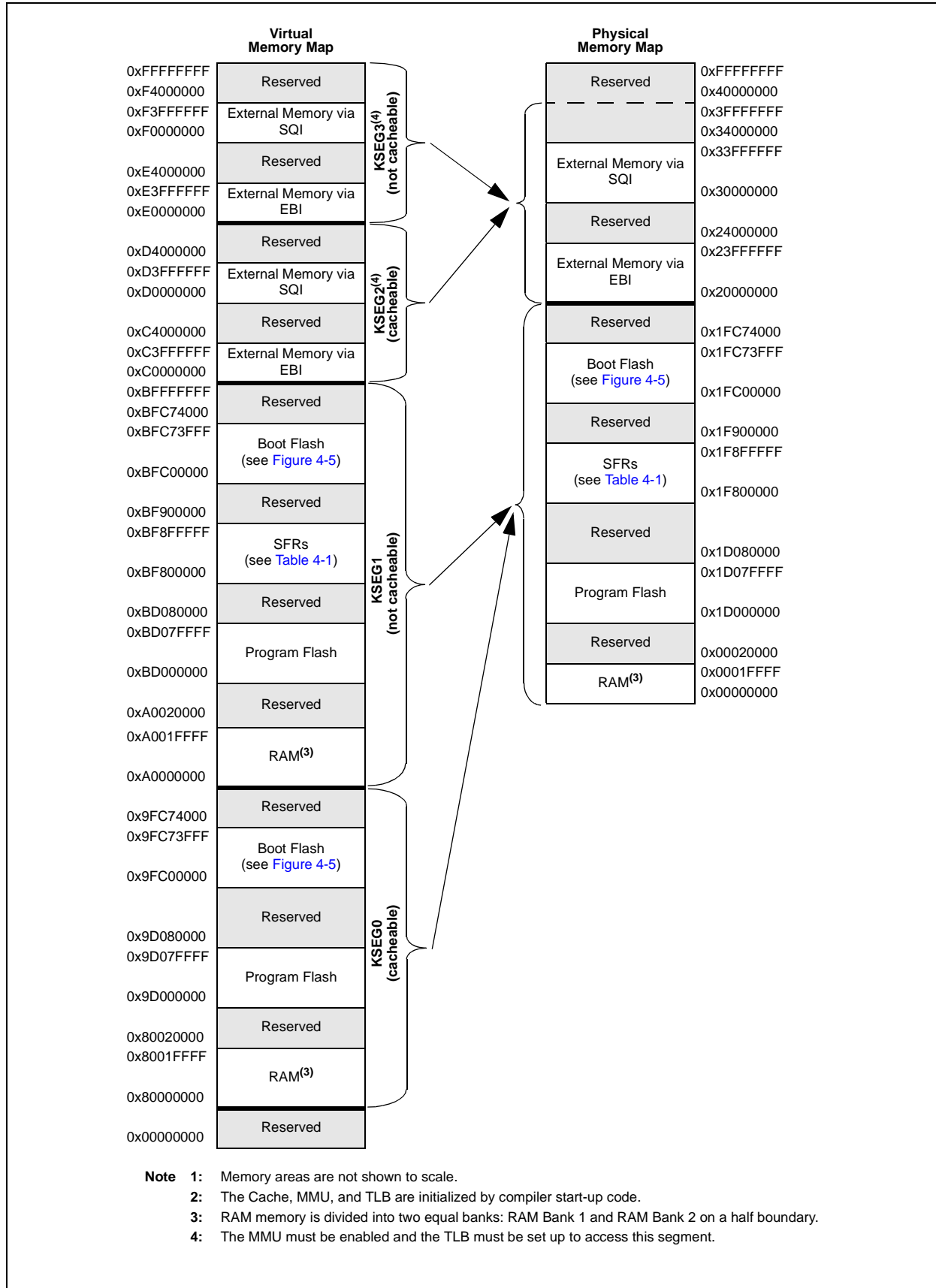

PIC32MZ Embedded Connectivity with Floating Point Unit (EF) Family

FIGURE 4-2: MEMORY MAP FOR DEVICES WITH 1024 KB OF PROGRAM MEMORY AND 256 KB OF RAM^(1,2)

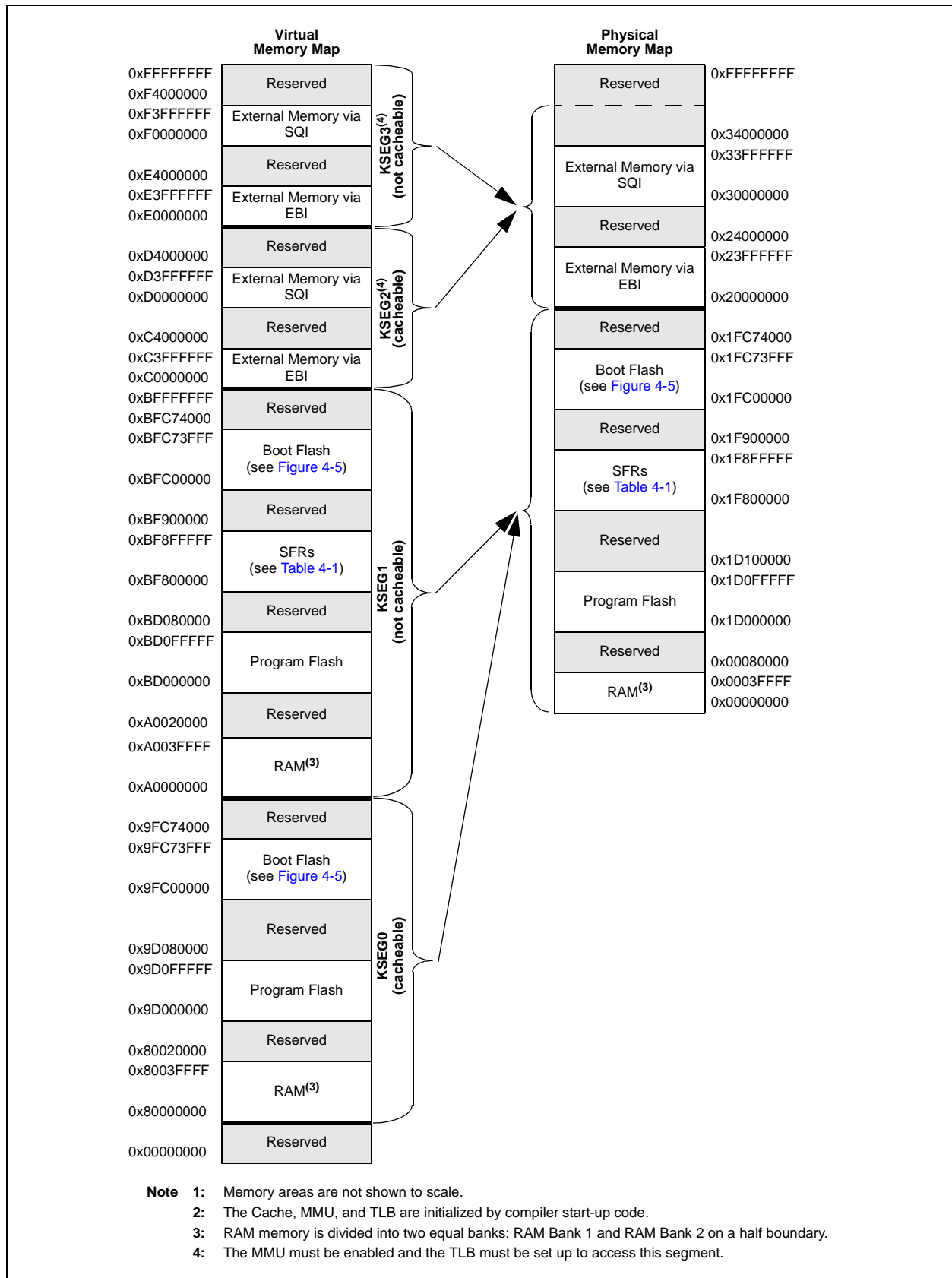

PIC32MZ Embedded Connectivity with Floating Point Unit (EF) Family

FIGURE 4-3: MEMORY MAP FOR DEVICES WITH 1024 KB OF PROGRAM MEMORY AND 512 KB OF RAM^(1,2)

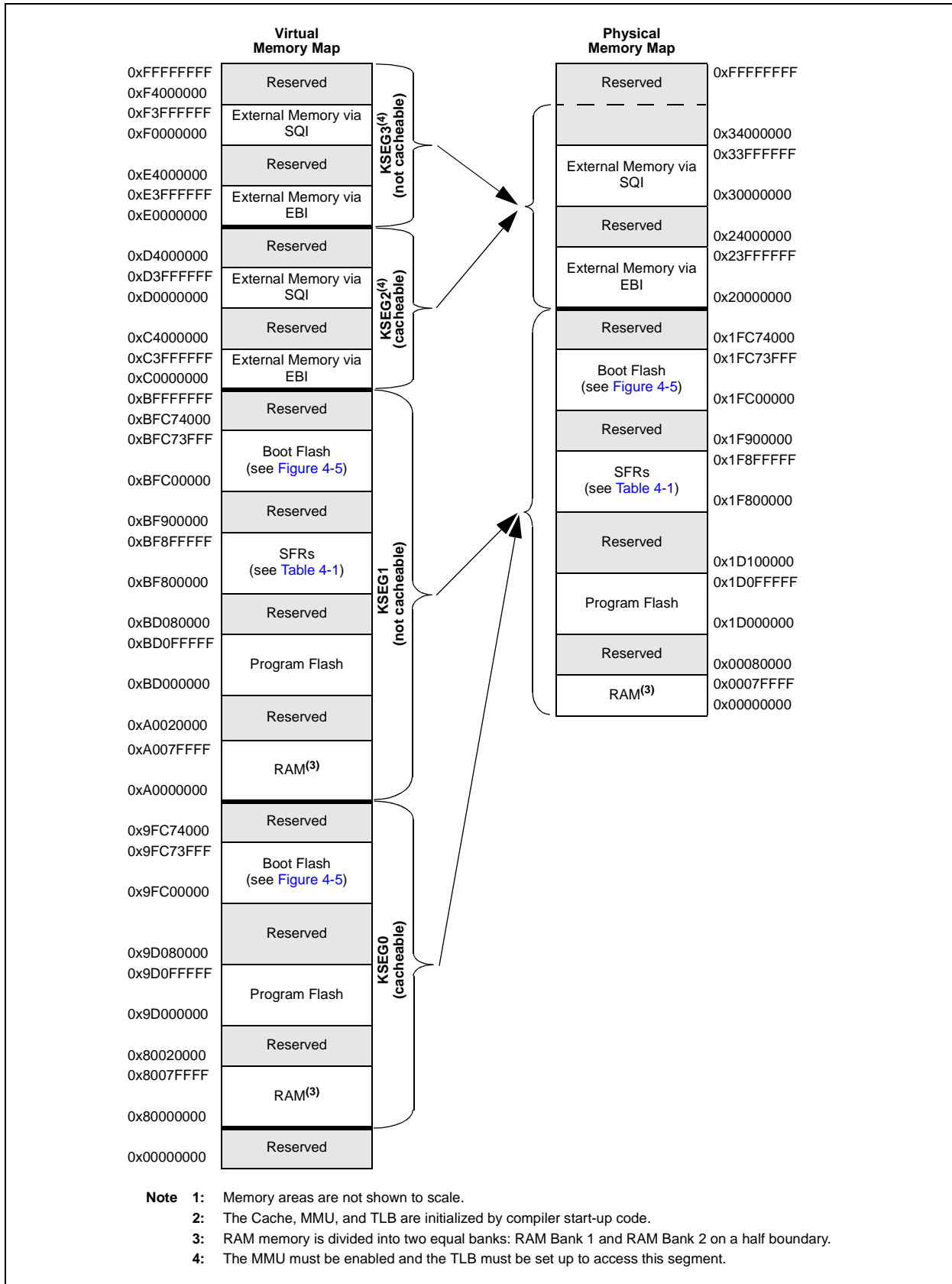

PIC32MZ Embedded Connectivity with Floating Point Unit (EF) Family

FIGURE 4-4: MEMORY MAP FOR DEVICES WITH 2048 KB OF PROGRAM MEMORY^(1,2)

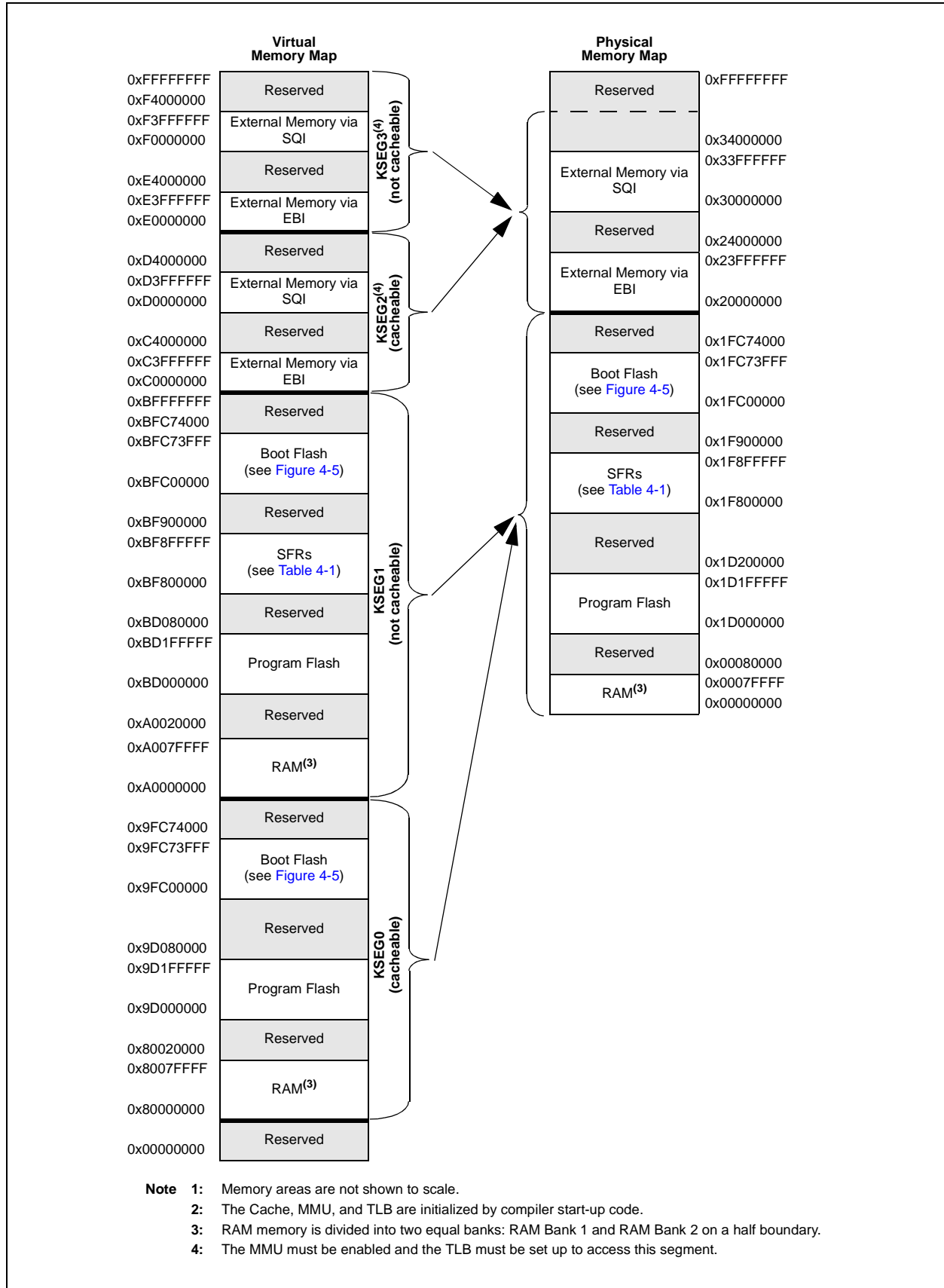

PIC32MZ Embedded Connectivity with Floating Point Unit (EF) Family

FIGURE 4-5: BOOT AND ALIAS MEMORY MAP

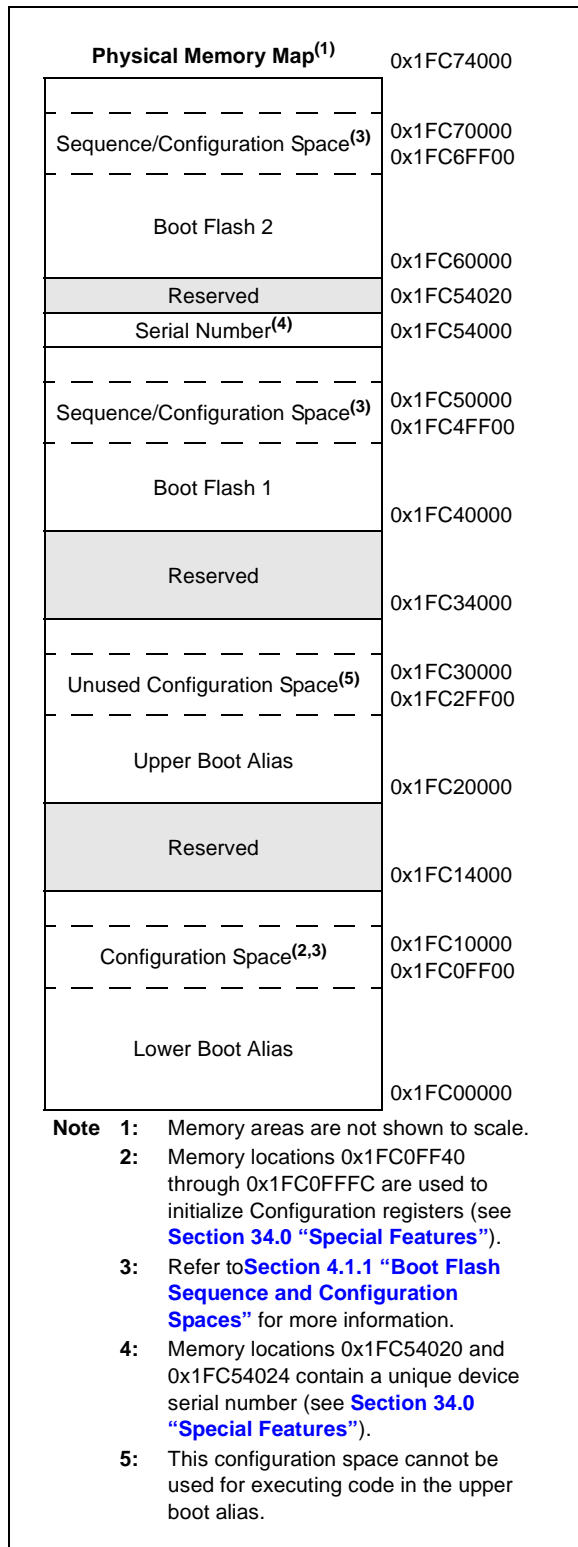

TABLE 4-1: SFR MEMORY MAP

| Peripheral | Virtual Address | |
|---------------------------|-----------------|--------------|
| | Base | Offset Start |
| System Bus ⁽¹⁾ | 0xBF8F0000 | 0x0000 |
| Prefetch | 0xBF8E0000 | 0x0000 |
| EBI | | 0x1000 |
| SQI1 | | 0x2000 |
| USB | | 0x3000 |
| Crypto | | 0x5000 |
| RNG | | 0x6000 |
| CAN1 and CAN2 | | 0xBF880000 |
| Ethernet | 0x2000 | |
| USBCR | 0x4000 | |
| PORTA-PORTK | 0xBF860000 | 0x0000 |
| Timer1-Timer9 | 0xBF840000 | 0x0000 |
| IC1-IC9 | | 0x2000 |
| OC1-OC9 | | 0x4000 |
| ADC | | 0xB000 |
| Comparator 1, 2 | | 0xC000 |
| I2C1-I2C5 | 0xBF820000 | 0x0000 |
| SPI1-SPI6 | | 0x1000 |
| UART1-UART6 | | 0x2000 |
| PMP | | 0xE000 |
| Interrupt Controller | 0xBF810000 | 0x0000 |
| DMA | | 0x1000 |
| Configuration | 0xBF800000 | 0x0000 |
| Flash Controller | | 0x0600 |
| Watchdog Timer | | 0x0800 |
| Deadman Timer | | 0x0A00 |
| RTCC | | 0x0C00 |
| CVREF | | 0x0E00 |
| Oscillator | | 0x1200 |
| PPS | | 0x1400 |

Note 1: Refer to [4.2 “System Bus Arbitration”](#) for important legal information.

PIC32MZ Embedded Connectivity with Floating Point Unit (EF) Family

4.1.1 BOOT FLASH SEQUENCE AND CONFIGURATION SPACES

Sequence space is used to identify which boot Flash is aliased by aliased regions. If the value programmed into the TSEQ<15:0> bits of the BF1SEQ0 word is equal to or greater than the value programmed into the TSEQ<15:0> bits of the BF2SEQ0 word, Boot Flash 1 is aliased by the lower boot alias region, and Boot Flash 2 is aliased by the upper boot alias region. If TSEQ<15:0> bits of BF2SEQ0 is greater than TSEQ<15:0> bits of BF1SEQ0, the opposite is true (see [Table 4-2](#) and [Table 4-3](#) for BFxSEQ0 word memory locations).

The CSEQ<15:0> bits must contain the one's complement value of the TSEQ<15:0> bits; otherwise, the value of TSEQ<15:0> is considered invalid, and an alternate sequence is used. See [Section 4.1.2 "Alternate Sequence and Configuration Words"](#) for more information.

Once boot Flash memories are aliased, configuration space located in the lower boot alias region is used as the basis for the Configuration words, DEVSIGN0, DEVCP0, and DEVCFGx (and the associated alternate configuration registers). This means that the boot Flash region to be aliased by lower boot alias region memory must contain configuration values in the appropriate memory locations.

| |
|---|
| <p>Note: Do not use word program operation (NVMOP<3:0> = 0001) when programming data into the sequence and configuration spaces.</p> |
|---|

4.1.2 ALTERNATE SEQUENCE AND CONFIGURATION WORDS

Every word in the configuration space and sequence space has an associated alternate word (designated by the letter A as the first letter in the name of the word). During device start-up, primary words are read and if uncorrectable ECC errors are found, the BCFGERR (RCON<27>) flag is set and alternate words are used. If uncorrectable ECC errors are found in primary and alternate words, the BCFGFAIL (RCON<26>) flag is set and the default configuration is used.

TABLE 4-2: BOOT FLASH 1 SEQUENCE AND CONFIGURATION WORDS SUMMARY

| Virtual Address (BFC4_#) | Register Name | Bit Range | Bits | | | | | | | | | | | | | | | All Reset | |
|--------------------------|---------------|-----------|---|-------|-------|-------|-------|-------|------|------|------|------|------|------|------|------|------|-----------|------|
| | | | 31/15 | 30/14 | 29/13 | 28/12 | 27/11 | 26/10 | 25/9 | 24/8 | 23/7 | 22/6 | 21/5 | 20/4 | 19/3 | 18/2 | 17/1 | | 16/0 |
| FF40 | ABF1DEVCFG3 | 31:0 | <p style="text-align: center;">Note: See Table 34-2 for the bit descriptions.</p> | | | | | | | | | | | | | | | xxxx | |
| FF44 | ABF1DEVCFG2 | 31:0 | | | | | | | | | | | | | | | | xxxx | |
| FF48 | ABF1DEVCFG1 | 31:0 | | | | | | | | | | | | | | | | xxxx | |
| FF4C | ABF1DEVCFG0 | 31:0 | | | | | | | | | | | | | | | | xxxx | |
| FF50 | ABF1DEVCP3 | 31:0 | | | | | | | | | | | | | | | | xxxx | |
| FF54 | ABF1DEVCP2 | 31:0 | | | | | | | | | | | | | | | | xxxx | |
| FF58 | ABF1DEVCP1 | 31:0 | | | | | | | | | | | | | | | | xxxx | |
| FF5C | ABF1DEVCP0 | 31:0 | | | | | | | | | | | | | | | | xxxx | |
| FF60 | ABF1DEVSIGN3 | 31:0 | | | | | | | | | | | | | | | | xxxx | |
| FF64 | ABF1DEVSIGN2 | 31:0 | | | | | | | | | | | | | | | | xxxx | |
| FF68 | ABF1DEVSIGN1 | 31:0 | | | | | | | | | | | | | | | | xxxx | |
| FF6C | ABF1DEVSIGN0 | 31:0 | | | | | | | | | | | | | | | | xxxx | |
| FF70 | ABF1SEQ3 | 31:16 | — | — | — | — | — | — | — | — | — | — | — | — | — | — | — | — | xxxx |
| | | 15:0 | — | — | — | — | — | — | — | — | — | — | — | — | — | — | — | — | xxxx |
| FFF4 | ABF1SEQ2 | 31:16 | — | — | — | — | — | — | — | — | — | — | — | — | — | — | — | — | xxxx |
| | | 15:0 | — | — | — | — | — | — | — | — | — | — | — | — | — | — | — | — | xxxx |
| FF78 | ABF1SEQ1 | 31:16 | — | — | — | — | — | — | — | — | — | — | — | — | — | — | — | — | xxxx |
| | | 15:0 | — | — | — | — | — | — | — | — | — | — | — | — | — | — | — | — | xxxx |
| FF7C | ABF1SEQ0 | 31:16 | CSEQ<15:0> | | | | | | | | | | | | | | | xxxx | |
| | | 15:0 | TSEQ<15:0> | | | | | | | | | | | | | | | xxxx | |
| FFC0 | BF1DEVCFG3 | 31:0 | <p style="text-align: center;">Note: See Table 34-1 for the bit descriptions.</p> | | | | | | | | | | | | | | | xxxx | |
| FFC4 | BF1DEVCFG2 | 31:0 | | | | | | | | | | | | | | | | xxxx | |
| FFC8 | BF1DEVCFG1 | 31:0 | | | | | | | | | | | | | | | | xxxx | |
| FFCC | BF1DEVCFG0 | 31:0 | | | | | | | | | | | | | | | | xxxx | |
| FFD0 | BF1DEVCP3 | 31:0 | | | | | | | | | | | | | | | | xxxx | |
| FFD4 | BF1DEVCP2 | 31:0 | | | | | | | | | | | | | | | | xxxx | |
| FFD8 | BF1DEVCP1 | 31:0 | | | | | | | | | | | | | | | | xxxx | |
| FFDC | BF1DEVCP0 | 31:0 | | | | | | | | | | | | | | | | xxxx | |
| FFE0 | BF1DEVSIGN3 | 31:0 | | | | | | | | | | | | | | | | xxxx | |
| FFE4 | BF1DEVSIGN2 | 31:0 | | | | | | | | | | | | | | | | xxxx | |
| FFE8 | BF1DEVSIGN1 | 31:0 | | | | | | | | | | | | | | | | xxxx | |
| FFEC | BF1DEVSIGN0 | 31:0 | | | | | | | | | | | | | | | | xxxx | |
| FFF0 | BF1SEQ3 | 31:16 | — | — | — | — | — | — | — | — | — | — | — | — | — | — | — | — | xxxx |
| | | 15:0 | — | — | — | — | — | — | — | — | — | — | — | — | — | — | — | — | xxxx |
| FFF4 | BF1SEQ2 | 31:16 | — | — | — | — | — | — | — | — | — | — | — | — | — | — | — | — | xxxx |
| | | 15:0 | — | — | — | — | — | — | — | — | — | — | — | — | — | — | — | — | xxxx |
| FFF8 | BF1SEQ1 | 31:16 | — | — | — | — | — | — | — | — | — | — | — | — | — | — | — | — | xxxx |
| | | 15:0 | — | — | — | — | — | — | — | — | — | — | — | — | — | — | — | — | xxxx |
| FFFC | BF1SEQ0 | 31:16 | CSEQ<15:0> | | | | | | | | | | | | | | | xxxx | |
| | | 15:0 | TSEQ<15:0> | | | | | | | | | | | | | | | xxxx | |

Legend: x = unknown value on Reset; — = Reserved, read as '1'. Reset values are shown in hexadecimal.

TABLE 4-3: BOOT FLASH 2 SEQUENCE AND CONFIGURATION WORDS SUMMARY

| Virtual Address (BFC6_#) | Register Name | Bit Range | Bits | | | | | | | | | | | | | | | All Resets | |
|-----------------------------|------------------|-----------|---|-------|-------|-------|-------|-------|------|------|------|------|------|------|------|------|------|------------|------|
| | | | 31/15 | 30/14 | 29/13 | 28/12 | 27/11 | 26/10 | 25/9 | 24/8 | 23/7 | 22/6 | 21/5 | 20/4 | 19/3 | 18/2 | 17/1 | | 16/0 |
| FF40 | ABF2DEVCFG3 | 31:0 | <p style="text-align: center;">Note: See Table 34-2 for the bit descriptions.</p> | | | | | | | | | | | | | | | xxxx | |
| FF44 | ABF2DEVCFG2 | 31:0 | | | | | | | | | | | | | | | | xxxx | |
| FF48 | ABF2DEVCFG1 | 31:0 | | | | | | | | | | | | | | | | xxxx | |
| FF4C | ABF2DEVCFG0 | 31:0 | | | | | | | | | | | | | | | | xxxx | |
| FF50 | ABF2DEVCP3 | 31:0 | | | | | | | | | | | | | | | | xxxx | |
| FF54 | ABF2DEVCP2 | 31:0 | | | | | | | | | | | | | | | | xxxx | |
| FF58 | ABF2DEVCP1 | 31:0 | | | | | | | | | | | | | | | | xxxx | |
| FF5C | ABF2DEVCP0 | 31:0 | | | | | | | | | | | | | | | | xxxx | |
| FF60 | ABF2DEVSIGN3 | 31:0 | | | | | | | | | | | | | | | | xxxx | |
| FF64 | ABF2DEVSIGN2 | 31:0 | | | | | | | | | | | | | | | | xxxx | |
| FF68 | ABF2DEVSIGN1 | 31:0 | | | | | | | | | | | | | | | | xxxx | |
| FF6C | ABF2DEVSIGN0 | 31:0 | | | | | | | | | | | | | | | | xxxx | |
| FF70 | ABF2SEQ3 | 31:16 | | | | | | | | | | | | | | | | — | — |
| | | 15:0 | — | — | — | — | — | — | — | — | — | — | — | — | — | — | — | — | — |
| FFF4 | ABF2SEQ2 | 31:16 | — | — | — | — | — | — | — | — | — | — | — | — | — | — | — | — | xxxx |
| | | 15:0 | — | — | — | — | — | — | — | — | — | — | — | — | — | — | — | — | — |
| FF78 | ABF2SEQ1 | 31:16 | — | — | — | — | — | — | — | — | — | — | — | — | — | — | — | — | xxxx |
| | | 15:0 | — | — | — | — | — | — | — | — | — | — | — | — | — | — | — | — | — |
| FF7C | ABF2SEQ0 | 31:16 | CSEQ<15:0> | | | | | | | | | | | | | | | xxxx | |
| | | 15:0 | TSEQ<15:0> | | | | | | | | | | | | | | | xxxx | |
| FFC0 | BF2DEVCFG3 | 31:0 | <p style="text-align: center;">Note: See Table 34-1 for the bit descriptions.</p> | | | | | | | | | | | | | | | xxxx | |
| FFC4 | BF2DEVCFG2 | 31:0 | | | | | | | | | | | | | | | | xxxx | |
| FFC8 | BF2DEVCFG1 | 31:0 | | | | | | | | | | | | | | | | xxxx | |
| FFCC | BF2DEVCFG0 | 31:0 | | | | | | | | | | | | | | | | xxxx | |
| FFD0 | BF2DEVCP3 | 31:0 | | | | | | | | | | | | | | | | xxxx | |
| FFD4 | BF2DEVCP2 | 31:0 | | | | | | | | | | | | | | | | xxxx | |
| FFD8 | BF2DEVCP1 | 31:0 | | | | | | | | | | | | | | | | xxxx | |
| FFDC | BF2DEVCP0 | 31:0 | | | | | | | | | | | | | | | | xxxx | |
| FFE0 | BF2DEVSIGN3 | 31:0 | | | | | | | | | | | | | | | | xxxx | |
| FFE4 | BF2DEVSIGN2 | 31:0 | | | | | | | | | | | | | | | | xxxx | |
| FFE8 | BF2DEVSIGN1 | 31:0 | | | | | | | | | | | | | | | | xxxx | |
| FFEC | BF2DEVSIGN0 | 31:0 | | | | | | | | | | | | | | | | xxxx | |
| FFF0 | BF2SEQ3 | 31:16 | | | | | | | | | | | | | | | | — | — |
| | | 15:0 | — | — | — | — | — | — | — | — | — | — | — | — | — | — | — | — | — |
| FFF4 | BF2SEQ2 | 31:16 | — | — | — | — | — | — | — | — | — | — | — | — | — | — | — | — | xxxx |
| | | 15:0 | — | — | — | — | — | — | — | — | — | — | — | — | — | — | — | — | — |
| FFF8 | BF2SEQ1 | 31:16 | — | — | — | — | — | — | — | — | — | — | — | — | — | — | — | — | xxxx |
| | | 15:0 | — | — | — | — | — | — | — | — | — | — | — | — | — | — | — | — | — |
| FFFC | BF2SEQ0 | 31:16 | CSEQ<15:0> | | | | | | | | | | | | | | | xxxx | |
| | | 15:0 | TSEQ<15:0> | | | | | | | | | | | | | | | xxxx | |

Legend: x = unknown value on Reset; — = Reserved, read as '1'. Reset values are shown in hexadecimal.

PIC32MZ Embedded Connectivity with Floating Point Unit (EF) Family

REGISTER 4-1: BFXSEQ0/ABFXSEQ0: BOOT FLASH 'x' SEQUENCE WORD 0 REGISTER ('x' = 1 AND 2)

| Bit Range | Bit 31/23/15/7 | Bit 30/22/14/6 | Bit 29/21/13/5 | Bit 28/20/12/4 | Bit 27/19/11/3 | Bit 26/18/10/2 | Bit 25/17/9/1 | Bit 24/16/8/0 |
|------------|----------------|----------------|----------------|----------------|----------------|----------------|---------------|---------------|
| 31:24 | R/P | R/P | R/P | R/P | R/P | R/P | R/P | R/P |
| CSEQ<15:8> | | | | | | | | |
| 23:16 | R/P | R/P | R/P | R/P | R/P | R/P | R/P | R/P |
| CSEQ<7:0> | | | | | | | | |
| 15:8 | R/P | R/P | R/P | R/P | R/P | R/P | R/P | R/P |
| TSEQ<15:8> | | | | | | | | |
| 7:0 | R/P | R/P | R/P | R/P | R/P | R/P | R/P | R/P |
| TSEQ<7:0> | | | | | | | | |

Legend:

R = Readable bit

W = Writable bit

P = Programmable bit

U = Unimplemented bit, read as '0'

-n = Value at POR

'1' = Bit is set

'0' = Bit is cleared

x = Bit is unknown

bit 31-16 **CSEQ<15:0>**: Boot Flash Complement Sequence Number bits

bit 15-0 **TSEQ<15:0>**: Boot Flash True Sequence Number bits

Note: The BFXSEQ1 through BFXSEQ3 and ABFXSEQ1 through ABFXSEQ3 registers are used for Quad Word programming operation when programming the BFXSEQ0/ABFXSEQ0 registers, and do not contain any valid information.

4.2 System Bus Arbitration

Note: The System Bus interconnect implements one or more instantiations of the SonicsSX[®] interconnect from Sonics, Inc. This document contains materials that are (c) 2003-2015 Sonics, Inc., and that constitute proprietary information of Sonics, Inc. SonicsSX is a registered trademark of Sonics, Inc. All such materials and trademarks are used under license from Sonics, Inc.

As shown in the PIC32MZ EF Family Block Diagram (see [Figure 1-1](#)), there are multiple initiator modules (I1 through I14) in the system that can access various target modules (T1 through T13). [Table 4-4](#) illustrates which initiator can access which target. The System Bus supports simultaneous access to targets by initiators, so long as the initiators are accessing different targets. The System Bus will perform arbitration, if multiple initiators attempt to access the same target.

TABLE 4-4: INITIATORS TO TARGETS ACCESS ASSOCIATION

| Target # | Initiator ID | 1 | 2 | 3 | 4 | 5 | 6 | 7 | 8 | 9 | 10 | 11 | 12 | 13 | 14 |
|----------|--|-----|---|----------|---|-----------|---|-----|---------------|----------------|------|------|------|------------------|--------|
| | Name | CPU | | DMA Read | | DMA Write | | USB | Ethernet Read | Ethernet Write | CAN1 | CAN2 | SQI1 | Flash Controller | Crypto |
| 1 | Flash Memory: Program Flash Boot Flash Prefetch Module | X | | X | | | | X | X | | X | X | | | X |
| 2 | RAM Bank 1 Memory | X | | X | | X | | X | X | X | X | X | X | X | X |
| 3 | RAM Bank 2 Memory | X | | X | | X | | X | X | X | X | X | X | X | X |
| 4 | External Memory via EBI and EBI Module | X | | X | | X | | X | X | X | X | X | X | | X |
| 5 | Peripheral Set 1: System Control, Flash Control, DMT, RTCC, CVR, PPS Input, PPS Output, Interrupts, DMA, WDT | X | | | | | | | | | | | | | |
| 6 | Peripheral Set 2: SPI1-SPI6 I2C1-I2C5 UART1-UART6 PMP | X | | X | | X | | | | | | | | | |
| 7 | Peripheral Set 3: Timer1-Timer9 IC1-IC9 OC1-OC9 ADC Comparator 1 Comparator 2 | X | | X | | X | | | | | | | | | |
| 8 | Peripheral Set 4: PORTA-PORTK | X | | X | | X | | | | | | | | | |
| 9 | Peripheral Set 5: CAN1 CAN2 Ethernet Controller | X | | | | | | | | | | | | | |
| 10 | Peripheral Set 6: USB | X | | | | | | | | | | | | | |
| 11 | External Memory via SQI1 and SQI1 Module | X | | | | | | | | | | | | | |
| 12 | Peripheral Set 7: Crypto Engine | X | | | | | | | | | | | | | |
| 13 | Peripheral Set 8: RNG Module | X | | | | | | | | | | | | | |

PIC32MZ Embedded Connectivity with Floating Point Unit (EF) Family

The System Bus arbitration scheme implements a non-programmable, Least Recently Serviced (LRS) priority, which provides Quality Of Service (QOS) for most initiators. However, some initiators can use Fixed High Priority (HIGH) arbitration to guarantee their access to data.

The arbitration scheme for the available initiators is shown in [Table 4-5](#).

TABLE 4-5: INITIATOR ID AND QOS

| Name | ID | QOS |
|------------------|----|-----------------------|
| CPU | 1 | LRS ⁽¹⁾ |
| CPU | 2 | HIGH ^(1,2) |
| DMA Read | 3 | LRS ⁽¹⁾ |
| DMA Read | 4 | HIGH ^(1,2) |
| DMA Write | 5 | LRS ⁽¹⁾ |
| DMA Write | 6 | HIGH ^(1,2) |
| USB | 7 | LRS |
| Ethernet Read | 8 | LRS |
| Ethernet Write | 9 | LRS |
| CAN1 | 10 | LRS |
| CAN2 | 11 | LRS |
| SQI1 | 12 | LRS |
| Flash Controller | 13 | HIGH ⁽²⁾ |
| Crypto | 14 | LRS |

Note 1: When accessing SRAM, the DMAPRI bit (CFGCON<25>) and the CPUPRI bit (CFGCON<24>) provide arbitration control for the DMA and CPU (when servicing an interrupt (i.e., EXL = 1)), respectively, by selecting the use of LRS or HIGH. When using HIGH, the DMA and CPU get arbitration preference over all initiators using LRS.

- 2:** Using HIGH arbitration can have serious negative effects on other initiators. Therefore, it is recommended to not enable this type of arbitration for an initiator that uses significant system bandwidth. HIGH arbitration is intended to be used for low bandwidth applications that require low latency, such as LCC graphics applications.

4.3 Permission Access and System Bus Registers

The System Bus on PIC32MZ EF family of microcontrollers provides access control capabilities for the transaction initiators on the System Bus.

The System Bus divides the entire memory space into fourteen target regions and permits access to each target by initiators via permission groups. Four Permission Groups (0 through 3) can be assigned to each initiator. Each permission group is independent of the others and can have exclusive or shared access to a region.

Using the CFGPG register (see [Register 34-10](#) in [Section 34.0 “Special Features”](#)), Boot firmware can assign a permission group to each initiator, which can make requests on the System Bus.

The available targets and their regions, as well as the associated control registers to assign protection, are described and listed in [Table 4-6](#).

[Register 4-2](#) through [Register 4-10](#) are used for setting and controlling access permission groups and regions.

To change these registers, they must be unlocked in hardware. The register lock is controlled by the PGLOCK Configuration bit (CFGCON<11>). Setting PGLOCK prevents writes to the control registers; clearing PGLOCK allows writes.

To set or clear the PGLOCK bit, an unlock sequence must be executed. Refer to [Section 42. “Oscillators with Enhanced PLL”](#) in the *“PIC32 Family Reference Manual”* for details.

TABLE 4-6: SYSTEM BUS TARGETS AND ASSOCIATED PROTECTION REGISTERS

| Target Number | Target Description ⁽⁵⁾ | SBTxREGy Register | | | | | | | SBTxRDy Register | | SBTxWRy Register | |
|---------------|--|-------------------|---------------------------------------|------------------------|--------------------------------------|------------------|----------------|----------------|------------------|--|------------------|---|
| | | Name | Region Base (BASE<21:0>) (see Note 2) | Physical Start Address | Region Size (SIZE<4:0>) (see Note 3) | Region Size | Priority (PRI) | Priority Level | Name | Read Permission (GROUP3, GROUP2, GROUP1, GROUP0) | Name | Write Permission (GROUP3, GROUP2, GROUP1, GROUP0) |
| 0 | System Bus | SBT0REG0 | R | 0x1F8F0000 | R | 64 KB | — | 0 | SBT0RD0 | R/W ⁽¹⁾ | SBT0WR0 | R/W ⁽¹⁾ |
| | | SBT0REG1 | R | 0x1F8F8000 | R | 32 KB | — | 3 | SBT0RD1 | R/W ⁽¹⁾ | SBT0WR1 | R/W ⁽¹⁾ |
| 1 | Flash Memory ⁽⁶⁾ : Program Flash Boot Flash Prefetch Module | SBT1REG0 | R | 0x1D000000 | R ⁽⁴⁾ | R ⁽⁴⁾ | — | 0 | SBT1RD0 | R/W ⁽¹⁾ | SBT1WR0 | 0, 0, 0, 0 |
| | | SBT1REG2 | R | 0x1F8E0000 | R | 4 KB | 1 | 2 | SBT1RD2 | R/W ⁽¹⁾ | SBT1WR2 | R/W ⁽¹⁾ |
| | | SBT1REG3 | R/W | R/W | R/W | R/W | 1 | 2 | SBT1RD3 | R/W ⁽¹⁾ | SBT1WR3 | 0, 0, 0, 0 |
| | | SBT1REG4 | R/W | R/W | R/W | R/W | 1 | 2 | SBT1RD4 | R/W ⁽¹⁾ | SBT1WR4 | 0, 0, 0, 0 |
| | | SBT1REG5 | R/W | R/W | R/W | R/W | 1 | 2 | SBT1RD5 | R/W ⁽¹⁾ | SBT1WR5 | 0, 0, 0, 0 |
| | | SBT1REG6 | R/W | R/W | R/W | R/W | 1 | 2 | SBT1RD6 | R/W ⁽¹⁾ | SBT1WR6 | 0, 0, 0, 0 |
| | | SBT1REG7 | R/W | R/W | R/W | R/W | 0 | 1 | SBT1RD7 | R/W ⁽¹⁾ | SBT1WR7 | 0, 0, 0, 0 |
| | | SBT1REG8 | R/W | R/W | R/W | R/W | 0 | 1 | SBT1RD8 | R/W ⁽¹⁾ | SBT1WR8 | 0, 0, 0, 0 |
| 2 | RAM Bank 1 Memory | SBT2REG0 | R | 0x00000000 | R ⁽⁴⁾ | R ⁽⁴⁾ | — | 0 | SBT2RD0 | R/W ⁽¹⁾ | SBT2WR0 | R/W ⁽¹⁾ |
| | | SBT2REG1 | R/W | R/W | R/W | R/W | — | 3 | SBT2RD1 | R/W ⁽¹⁾ | SBT2WR1 | R/W ⁽¹⁾ |
| | | SBT2REG2 | R/W | R/W | R/W | R/W | 0 | 1 | SBT2RD2 | R/W ⁽¹⁾ | SBT2WR2 | R/W ⁽¹⁾ |
| 3 | RAM Bank 2 Memory | SBT3REG0 | R ⁽⁴⁾ | R ⁽⁴⁾ | R ⁽⁴⁾ | R ⁽⁴⁾ | — | 0 | SBT3RD0 | R/W ⁽¹⁾ | SBT3WR0 | R/W ⁽¹⁾ |
| | | SBT3REG1 | R/W | R/W | R/W | R/W | — | 3 | SBT3RD1 | R/W ⁽¹⁾ | SBT3WR1 | R/W ⁽¹⁾ |
| | | SBT3REG2 | R/W | R/W | R/W | R/W | 0 | 1 | SBT3RD2 | R/W ⁽¹⁾ | SBT3WR2 | R/W ⁽¹⁾ |
| 4 | External Memory via EBI and EBI Module ⁽⁶⁾ | SBT4REG0 | R | 0x20000000 | R | 64 MB | — | 0 | SBT4RD0 | R/W ⁽¹⁾ | SBT4WR0 | R/W ⁽¹⁾ |
| | | SBT4REG2 | R | 0x1F8E1000 | R | 4 KB | 0 | 1 | SBT4RD2 | R/W ⁽¹⁾ | SBT4WR2 | R/W ⁽¹⁾ |
| 5 | Peripheral Set 1: System Control Flash Control DMT/WDT RTCC CVR PPS Input PPS Output Interrupts DMA | SBT5REG0 | R | 0x1F800000 | R | 128 KB | — | 0 | SBT5RD0 | R/W ⁽¹⁾ | SBT5WR0 | R/W ⁽¹⁾ |
| | | SBT5REG1 | R/W | R/W | R/W | R/W | — | 3 | SBT5RD1 | R/W ⁽¹⁾ | SBT5WR1 | R/W ⁽¹⁾ |
| | | SBT5REG2 | R/W | R/W | R/W | R/W | 0 | 1 | SBT5RD2 | R/W ⁽¹⁾ | SBT5WR2 | R/W ⁽¹⁾ |

Legend: R = Read; R/W = Read/Write; 'x' in a register name = 0-13; 'y' in a register name = 0-8.

Note 1: Reset values for these bits are '0', '1', '1', '1', respectively.

Note 2: The BASE<21:0> bits must be set to the corresponding Physical Address and right shifted by 10 bits. For Read-only bits, this value is set by hardware on Reset.

Note 3: The SIZE<4:0> bits must be set to the corresponding Region Size, based on the following formula: Region Size = $2^{(SIZE-1)} \times 1024$ bytes. For read-only bits, this value is set by hardware on Reset.

Note 4: Refer to the Device Memory Maps (Figure 4-1 through Figure 4-4) for specific device memory sizes and start addresses.

Note 5: See Table 4-1 for information on specific target memory size and start addresses.

Note 6: The SBTxREG1 SFRs are reserved, and therefore, are not listed in this table for this target.

TABLE 4-6: SYSTEM BUS TARGETS AND ASSOCIATED PROTECTION REGISTERS (CONTINUED)

| Target Number | Target Description ⁽⁵⁾ | SBTxREGy Register | | | | | | | SBTxRDy Register | | SBTxWRy Register | |
|---------------|---|-------------------|---------------------------------------|------------------------|--------------------------------------|-------------|----------------|----------------|------------------|--|------------------|---|
| | | Name | Region Base (BASE<21:0>) (see Note 2) | Physical Start Address | Region Size (SIZE<4:0>) (see Note 3) | Region Size | Priority (PRI) | Priority Level | Name | Read Permission (GROUP3, GROUP2, GROUP1, GROUP0) | Name | Write Permission (GROUP3, GROUP2, GROUP1, GROUP0) |
| 6 | Peripheral Set 2: SPI1-SPI6 I2C1-I2C5 UART1-UART6 PMP | SBT6REG0 | R | 0x1F820000 | R | 64 KB | — | 0 | SBT6RD0 | R/W ⁽¹⁾ | SBT6WR0 | R/W ⁽¹⁾ |
| | | SBT6REG1 | R/W | R/W | R/W | R/W | — | 3 | SBT6RD1 | R/W ⁽¹⁾ | SBT6WR1 | R/W ⁽¹⁾ |
| 7 | Peripheral Set 3: Timer1-Timer9 IC1-IC9 OC1-OC9 ADC Comparator 1 Comparator 2 | SBT7REG0 | R | 0x1F840000 | R | 64 KB | — | 0 | SBT7RD0 | R/W ⁽¹⁾ | SBT7WR0 | R/W ⁽¹⁾ |
| | | SBT7REG1 | R/W | R/W | R/W | R/W | — | 3 | SBT7RD1 | R/W ⁽¹⁾ | SBT7WR1 | R/W ⁽¹⁾ |
| 8 | Peripheral Set 4: PORTA-PORTK | SBT8REG0 | R | 0x1F860000 | R | 64 KB | — | 0 | SBT8RD0 | R/W ⁽¹⁾ | SBT8WR0 | R/W ⁽¹⁾ |
| | | SBT8REG1 | R/W | R/W | R/W | R/W | — | 3 | SBT8RD1 | R/W ⁽¹⁾ | SBT8WR1 | R/W ⁽¹⁾ |
| 9 | Peripheral Set 5: CAN1 CAN2 Ethernet Controller | SBT9REG0 | R | 0x1F880000 | R | 64 KB | — | 0 | SBT9RD0 | R/W ⁽¹⁾ | SBT9WR0 | R/W ⁽¹⁾ |
| | | SBT9REG1 | R/W | R/W | R/W | R/W | — | 3 | SBT9RD1 | R/W ⁽¹⁾ | SBT9WR1 | R/W ⁽¹⁾ |
| 10 | Peripheral Set 6: USB | SBT10REG0 | R | 0x1F8E3000 | R | 4 KB | — | 0 | SBT10RD0 | R/W ⁽¹⁾ | SBT10WR0 | R/W ⁽¹⁾ |
| 11 | External Memory via SQI1 and SQI1 Module | SBT11REG0 | R | 0x30000000 | R | 64 MB | — | 0 | SBT11RD0 | R/W ⁽¹⁾ | SBT11WR0 | R/W ⁽¹⁾ |
| | | SBT11REG1 | R | 0x1F8E2000 | R | 4 KB | — | 3 | SBT11RD1 | R/W ⁽¹⁾ | SBT11WR1 | R/W ⁽¹⁾ |
| 12 | Peripheral Set 7: Crypto Engine | SBT12REG0 | R | 0x1F8E5000 | R | 4 KB | — | 0 | SBT12RD0 | R/W ⁽¹⁾ | SBT12WR0 | R/W ⁽¹⁾ |
| 13 | Peripheral Set 8: RNG Module | SBT13REG0 | R | 0x1F8E6000 | R | 4 KB | — | 0 | SBT13RD0 | R/W ⁽¹⁾ | SBT13WR0 | R/W ⁽¹⁾ |

Legend: R = Read; R/W = Read/Write; 'x' in a register name = 0-13; 'y' in a register name = 0-8.

Note 1: Reset values for these bits are '0', '1', '1', '1', respectively.

Note 2: The BASE<21:0> bits must be set to the corresponding Physical Address and right shifted by 10 bits. For Read-only bits, this value is set by hardware on Reset.

Note 3: The SIZE<4:0> bits must be set to the corresponding Region Size, based on the following formula: Region Size = $2^{(SIZE-1)} \times 1024$ bytes. For read-only bits, this value is set by hardware on Reset.

Note 4: Refer to the Device Memory Maps (Figure 4-1 through Figure 4-4) for specific device memory sizes and start addresses.

Note 5: See Table 4-1 for information on specific target memory size and start addresses.

Note 6: The SBTxREG1 SFRs are reserved, and therefore, are not listed in this table for this target.

TABLE 4-7: SYSTEM BUS REGISTER MAP

| Virtual Address (BF8F_#) | Register Name | Bit Range | Bits | | | | | | | | | | | | | | All Resets | | |
|--------------------------|---------------|-----------|-------|-------|--------|--------|--------|--------|-------|-------|-------|-------|-------|-------|-------|-------|------------|-------|------|
| | | | 31/15 | 30/14 | 29/13 | 28/12 | 27/11 | 26/10 | 25/9 | 24/8 | 23/7 | 22/6 | 21/5 | 20/4 | 19/3 | 18/2 | | 17/1 | 16/0 |
| 0510 | SBFLAG | 31:16 | — | — | — | — | — | — | — | — | — | — | — | — | — | — | — | — | 0000 |
| | | 15:0 | — | — | T13PGV | T12PGV | T11PGV | T10PGV | T9PGV | T8PGV | T7PGV | T6PGV | T5PGV | T4PGV | T3PGV | T2PGV | T1PGV | T0PGV | 0000 |

Legend: x = unknown value on Reset; — = unimplemented, read as '0'. Reset values are shown in hexadecimal.

TABLE 4-8: SYSTEM BUS TARGET 0 REGISTER MAP

| Virtual Address (BF8F_#) | Register Name | Bit Range | Bits | | | | | | | | | | | | | | All Resets | | |
|--------------------------|---------------|-----------|-------------|-------|-------|-------|-------|-------|------|-------------|------|-----------|------|------|------|--------|------------|------------|--------|
| | | | 31/15 | 30/14 | 29/13 | 28/12 | 27/11 | 26/10 | 25/9 | 24/8 | 23/7 | 22/6 | 21/5 | 20/4 | 19/3 | 18/2 | | 17/1 | 16/0 |
| 8020 | SBT0ELOG1 | 31:16 | MULTI | — | — | — | — | — | — | — | — | — | — | — | — | — | — | — | 0000 |
| | | 15:0 | INITID<7:0> | | | | | | | REGION<3:0> | | | | | | | CMD<2:0> | | |
| 8024 | SBT0ELOG2 | 31:16 | — | — | — | — | — | — | — | — | — | — | — | — | — | — | — | — | 0000 |
| | | 15:0 | — | — | — | — | — | — | — | — | — | — | — | — | — | — | — | GROUP<1:0> | 0000 |
| 8028 | SBT0ECON | 31:16 | — | — | — | — | — | — | — | ERRP | — | — | — | — | — | — | — | — | 0000 |
| | | 15:0 | — | — | — | — | — | — | — | — | — | — | — | — | — | — | — | — | 0000 |
| 8030 | SBT0ECLRS | 31:16 | — | — | — | — | — | — | — | — | — | — | — | — | — | — | — | — | 0000 |
| | | 15:0 | — | — | — | — | — | — | — | — | — | — | — | — | — | — | — | CLEAR | 0000 |
| 8038 | SBT0ECLRM | 31:16 | — | — | — | — | — | — | — | — | — | — | — | — | — | — | — | — | 0000 |
| | | 15:0 | — | — | — | — | — | — | — | — | — | — | — | — | — | — | — | CLEAR | 0000 |
| 8040 | SBT0REG0 | 31:16 | BASE<21:6> | | | | | | | | | | | | | | xxxxx | | |
| | | 15:0 | BASE<5:0> | | | | | | | PRI | — | SIZE<4:0> | | | | | | — | — |
| 8050 | SBT0RD0 | 31:16 | — | — | — | — | — | — | — | — | — | — | — | — | — | — | — | — | xxxxx |
| | | 15:0 | — | — | — | — | — | — | — | — | — | — | — | — | — | GROUP3 | GROUP2 | GROUP1 | GROUP0 |
| 8058 | SBT0WR0 | 31:16 | — | — | — | — | — | — | — | — | — | — | — | — | — | — | — | — | xxxxx |
| | | 15:0 | — | — | — | — | — | — | — | — | — | — | — | — | — | GROUP3 | GROUP2 | GROUP1 | GROUP0 |
| 8060 | SBT0REG1 | 31:16 | BASE<21:6> | | | | | | | | | | | | | | xxxxx | | |
| | | 15:0 | BASE<5:0> | | | | | | | PRI | — | SIZE<4:0> | | | | | | — | — |
| 8070 | SBT0RD1 | 31:16 | — | — | — | — | — | — | — | — | — | — | — | — | — | — | — | — | xxxxx |
| | | 15:0 | — | — | — | — | — | — | — | — | — | — | — | — | — | GROUP3 | GROUP2 | GROUP1 | GROUP0 |
| 8078 | SBT0WR1 | 31:16 | — | — | — | — | — | — | — | — | — | — | — | — | — | — | — | — | xxxxx |
| | | 15:0 | — | — | — | — | — | — | — | — | — | — | — | — | — | GROUP3 | GROUP2 | GROUP1 | GROUP0 |

Legend: x = unknown value on Reset; — = unimplemented, read as '0'. Reset values are shown in hexadecimal.

Note: For reset values listed as 'xxxxx', please refer to [Table 4-6](#) for the actual reset values.

TABLE 4-9: SYSTEM BUS TARGET 1 REGISTER MAP

| Virtual Address (BF8F_#) | Register Name | Bit Range | Bits | | | | | | | | | | | | | | All Resets | | |
|--------------------------|---------------|-----------|-------------|-------|-------|-------|-------------|-------|-----------|------|------|----------|------|------|--------|------------|------------|--------|------|
| | | | 31/15 | 30/14 | 29/13 | 28/12 | 27/11 | 26/10 | 25/9 | 24/8 | 23/7 | 22/6 | 21/5 | 20/4 | 19/3 | 18/2 | | 17/1 | 16/0 |
| 8420 | SBT1ELOG1 | 31:16 | MULTI | — | — | — | CODE<3:0> | | | | — | — | — | — | — | — | — | — | 0000 |
| | | 15:0 | INITID<7:0> | | | | REGION<3:0> | | | | — | CMD<2:0> | | | | 0000 | | | |
| 8424 | SBT1ELOG2 | 31:16 | — | — | — | — | — | — | — | — | — | — | — | — | — | — | — | 0000 | |
| | | 15:0 | — | — | — | — | — | — | — | — | — | — | — | — | — | GROUP<1:0> | | 0000 | |
| 8428 | SBT1ECON | 31:16 | — | — | — | — | — | — | ERRP | — | — | — | — | — | — | — | — | 0000 | |
| | | 15:0 | — | — | — | — | — | — | — | — | — | — | — | — | — | — | — | 0000 | |
| 8430 | SBT1ECLRS | 31:16 | — | — | — | — | — | — | — | — | — | — | — | — | — | — | — | 0000 | |
| | | 15:0 | — | — | — | — | — | — | — | — | — | — | — | — | — | — | CLEAR | 0000 | |
| 8438 | SBT1ECLRM | 31:16 | — | — | — | — | — | — | — | — | — | — | — | — | — | — | — | 0000 | |
| | | 15:0 | — | — | — | — | — | — | — | — | — | — | — | — | — | — | CLEAR | 0000 | |
| 8440 | SBT1REG0 | 31:16 | BASE<21:6> | | | | | | | | | | | | | | xxxx | | |
| | | 15:0 | BASE<5:0> | | | | PRI | — | SIZE<4:0> | | | | — | — | — | — | xxxx | | |
| 8450 | SBT1RD0 | 31:16 | — | — | — | — | — | — | — | — | — | — | — | — | — | — | — | xxxx | |
| | | 15:0 | — | — | — | — | — | — | — | — | — | — | — | — | GROUP3 | GROUP2 | GROUP1 | GROUP0 | xxxx |
| 8458 | SBT1WR0 | 31:16 | — | — | — | — | — | — | — | — | — | — | — | — | — | — | — | xxxx | |
| | | 15:0 | — | — | — | — | — | — | — | — | — | — | — | — | GROUP3 | GROUP2 | GROUP1 | GROUP0 | xxxx |
| 8480 | SBT1REG2 | 31:16 | BASE<21:6> | | | | | | | | | | | | | | xxxx | | |
| | | 15:0 | BASE<5:0> | | | | PRI | — | SIZE<4:0> | | | | — | — | — | — | xxxx | | |
| 8490 | SBT1RD2 | 31:16 | — | — | — | — | — | — | — | — | — | — | — | — | — | — | — | xxxx | |
| | | 15:0 | — | — | — | — | — | — | — | — | — | — | — | — | GROUP3 | GROUP2 | GROUP1 | GROUP0 | xxxx |
| 8498 | SBT1WR2 | 31:16 | — | — | — | — | — | — | — | — | — | — | — | — | — | — | — | xxxx | |
| | | 15:0 | — | — | — | — | — | — | — | — | — | — | — | — | GROUP3 | GROUP2 | GROUP1 | GROUP0 | xxxx |
| 84A0 | SBT1REG3 | 31:16 | BASE<21:6> | | | | | | | | | | | | | | xxxx | | |
| | | 15:0 | BASE<5:0> | | | | PRI | — | SIZE<4:0> | | | | — | — | — | — | xxxx | | |
| 84B0 | SBT1RD3 | 31:16 | — | — | — | — | — | — | — | — | — | — | — | — | — | — | — | xxxx | |
| | | 15:0 | — | — | — | — | — | — | — | — | — | — | — | — | GROUP3 | GROUP2 | GROUP1 | GROUP0 | xxxx |
| 84B8 | SBT1WR3 | 31:16 | — | — | — | — | — | — | — | — | — | — | — | — | — | — | — | xxxx | |
| | | 15:0 | — | — | — | — | — | — | — | — | — | — | — | — | GROUP3 | GROUP2 | GROUP1 | GROUP0 | xxxx |
| 84C0 | SBT1REG4 | 31:16 | BASE<21:6> | | | | | | | | | | | | | | xxxx | | |
| | | 15:0 | BASE<5:0> | | | | PRI | — | SIZE<4:0> | | | | — | — | — | — | xxxx | | |
| 84D0 | SBT1RD4 | 31:16 | — | — | — | — | — | — | — | — | — | — | — | — | — | — | — | xxxx | |
| | | 15:0 | — | — | — | — | — | — | — | — | — | — | — | — | GROUP3 | GROUP2 | GROUP1 | GROUP0 | xxxx |
| 84D8 | SBT1WR4 | 31:16 | — | — | — | — | — | — | — | — | — | — | — | — | — | — | — | xxxx | |
| | | 15:0 | — | — | — | — | — | — | — | — | — | — | — | — | GROUP3 | GROUP2 | GROUP1 | GROUP0 | xxxx |

Legend: x = unknown value on Reset; — = unimplemented, read as '0'. Reset values are shown in hexadecimal.

Note: For reset values listed as 'xxxx', please refer to [Table 4-6](#) for the actual reset values.

TABLE 4-9: SYSTEM BUS TARGET 1 REGISTER MAP (CONTINUED)

| Virtual Address (BF8F_#) | Register Name | Bit Range | Bits | | | | | | | | | | | | | | All Resets | |
|-----------------------------|------------------|--------------|------------|-------|-------|-------|-------|-------|------|-----------|------|------|------|------|--------|--------|---------------|--------|
| | | | 31/15 | 30/14 | 29/13 | 28/12 | 27/11 | 26/10 | 25/9 | 24/8 | 23/7 | 22/6 | 21/5 | 20/4 | 19/3 | 18/2 | | 17/1 |
| 84E0 | SBT1REG5 | 31:16 | BASE<21:6> | | | | | | | | | | | | | | xxxx | |
| | | 15:0 | BASE<5:0> | | | | | PRI | — | SIZE<4:0> | | | | | — | — | — | xxxx |
| 84F0 | SBT1RD5 | 31:16 | — | — | — | — | — | — | — | — | — | — | — | — | — | — | — | xxxx |
| | | 15:0 | — | — | — | — | — | — | — | — | — | — | — | — | GROUP3 | GROUP2 | GROUP1 | GROUP0 |
| 84F8 | SBT1WR5 | 31:16 | — | — | — | — | — | — | — | — | — | — | — | — | — | — | — | xxxx |
| | | 15:0 | — | — | — | — | — | — | — | — | — | — | — | — | GROUP3 | GROUP2 | GROUP1 | GROUP0 |
| 8500 | SBT1REG6 | 31:16 | BASE<21:6> | | | | | | | | | | | | | | xxxx | |
| | | 15:0 | BASE<5:0> | | | | | PRI | — | SIZE<4:0> | | | | | — | — | — | xxxx |
| 8510 | SBT1RD6 | 31:16 | — | — | — | — | — | — | — | — | — | — | — | — | — | — | — | xxxx |
| | | 15:0 | — | — | — | — | — | — | — | — | — | — | — | — | GROUP3 | GROUP2 | GROUP1 | GROUP0 |
| 8518 | SBT1WR6 | 31:16 | — | — | — | — | — | — | — | — | — | — | — | — | — | — | — | xxxx |
| | | 15:0 | — | — | — | — | — | — | — | — | — | — | — | — | GROUP3 | GROUP2 | GROUP1 | GROUP0 |
| 8520 | SBT1REG7 | 31:16 | BASE<21:6> | | | | | | | | | | | | | | xxxx | |
| | | 15:0 | BASE<5:0> | | | | | PRI | — | SIZE<4:0> | | | | | — | — | — | xxxx |
| 8530 | SBT1RD7 | 31:16 | — | — | — | — | — | — | — | — | — | — | — | — | — | — | — | xxxx |
| | | 15:0 | — | — | — | — | — | — | — | — | — | — | — | — | GROUP3 | GROUP2 | GROUP1 | GROUP0 |
| 8538 | SBT1WR7 | 31:16 | — | — | — | — | — | — | — | — | — | — | — | — | — | — | — | xxxx |
| | | 15:0 | — | — | — | — | — | — | — | — | — | — | — | — | GROUP3 | GROUP2 | GROUP1 | GROUP0 |
| 8540 | SBT1REG8 | 31:16 | BASE<21:6> | | | | | | | | | | | | | | xxxx | |
| | | 15:0 | BASE<5:0> | | | | | PRI | — | SIZE<4:0> | | | | | — | — | — | xxxx |
| 8550 | SBT1RD8 | 31:16 | — | — | — | — | — | — | — | — | — | — | — | — | — | — | — | xxxx |
| | | 15:0 | — | — | — | — | — | — | — | — | — | — | — | — | GROUP3 | GROUP2 | GROUP1 | GROUP0 |
| 8558 | SBT1WR8 | 31:16 | — | — | — | — | — | — | — | — | — | — | — | — | — | — | — | xxxx |
| | | 15:0 | — | — | — | — | — | — | — | — | — | — | — | — | GROUP3 | GROUP2 | GROUP1 | GROUP0 |

Legend: x = unknown value on Reset; — = unimplemented, read as '0'. Reset values are shown in hexadecimal.

Note: For reset values listed as 'xxxx', please refer to [Table 4-6](#) for the actual reset values.

TABLE 4-10: SYSTEM BUS TARGET 2 REGISTER MAP

| Virtual Address (BF8F_#) | Register Name | Bit Range | Bits | | | | | | | | | | | | | | All Resets | | |
|-----------------------------|---------------|-----------|-------------|-------|-------|-------|-------------|-------|-----------|------|------|----------|------|--------|------------|--------|------------|------|------|
| | | | 31/15 | 30/14 | 29/13 | 28/12 | 27/11 | 26/10 | 25/9 | 24/8 | 23/7 | 22/6 | 21/5 | 20/4 | 19/3 | 18/2 | | 17/1 | 16/0 |
| 8820 | SBT2ELOG1 | 31:16 | MULTI | — | — | — | CODE<3:0> | | | | — | — | — | — | — | — | — | — | 0000 |
| | | 15:0 | INITID<7:0> | | | | REGION<3:0> | | | | — | CMD<2:0> | | | | 0000 | | | |
| 8824 | SBT2ELOG2 | 31:16 | — | — | — | — | — | — | — | — | — | — | — | — | — | — | — | 0000 | |
| | | 15:0 | — | — | — | — | — | — | — | — | — | — | — | — | GROUP<1:0> | | | 0000 | |
| 8828 | SBT2ECON | 31:16 | — | — | — | — | — | — | ERRP | — | — | — | — | — | — | — | — | 0000 | |
| | | 15:0 | — | — | — | — | — | — | — | — | — | — | — | — | — | — | — | 0000 | |
| 8830 | SBT2ECLRS | 31:16 | — | — | — | — | — | — | — | — | — | — | — | — | — | — | — | 0000 | |
| | | 15:0 | — | — | — | — | — | — | — | — | — | — | — | — | — | — | CLEAR | 0000 | |
| 8838 | SBT2ECLRM | 31:16 | — | — | — | — | — | — | — | — | — | — | — | — | — | — | — | 0000 | |
| | | 15:0 | — | — | — | — | — | — | — | — | — | — | — | — | — | — | CLEAR | 0000 | |
| 8840 | SBT2REG0 | 31:16 | BASE<21:6> | | | | | | | | | | | | | | xxxx | | |
| | | 15:0 | BASE<5:0> | | | | PRI | — | SIZE<4:0> | | | | — | — | — | — | xxxx | | |
| 8850 | SBT2RD0 | 31:16 | — | — | — | — | — | — | — | — | — | — | — | — | — | — | — | xxxx | |
| | | 15:0 | — | — | — | — | — | — | — | — | — | — | — | GROUP3 | GROUP2 | GROUP1 | GROUP0 | xxxx | |
| 8858 | SBT2WR0 | 31:16 | — | — | — | — | — | — | — | — | — | — | — | — | — | — | — | xxxx | |
| | | 15:0 | — | — | — | — | — | — | — | — | — | — | — | GROUP3 | GROUP2 | GROUP1 | GROUP0 | xxxx | |
| 8860 | SBT2REG1 | 31:16 | BASE<21:6> | | | | | | | | | | | | | | xxxx | | |
| | | 15:0 | BASE<5:0> | | | | PRI | — | SIZE<4:0> | | | | — | — | — | — | xxxx | | |
| 8870 | SBT2RD1 | 31:16 | — | — | — | — | — | — | — | — | — | — | — | — | — | — | — | xxxx | |
| | | 15:0 | — | — | — | — | — | — | — | — | — | — | — | GROUP3 | GROUP2 | GROUP1 | GROUP0 | xxxx | |
| 8878 | SBT2WR1 | 31:16 | — | — | — | — | — | — | — | — | — | — | — | — | — | — | — | xxxx | |
| | | 15:0 | — | — | — | — | — | — | — | — | — | — | — | GROUP3 | GROUP2 | GROUP1 | GROUP0 | xxxx | |
| 8880 | SBT2REG2 | 31:16 | BASE<21:6> | | | | | | | | | | | | | | xxxx | | |
| | | 15:0 | BASE<5:0> | | | | PRI | — | SIZE<4:0> | | | | — | — | — | — | xxxx | | |
| 8890 | SBT2RD2 | 31:16 | — | — | — | — | — | — | — | — | — | — | — | — | — | — | — | xxxx | |
| | | 15:0 | — | — | — | — | — | — | — | — | — | — | — | GROUP3 | GROUP2 | GROUP1 | GROUP0 | xxxx | |
| 8898 | SBT2WR2 | 31:16 | — | — | — | — | — | — | — | — | — | — | — | — | — | — | — | xxxx | |
| | | 15:0 | — | — | — | — | — | — | — | — | — | — | — | GROUP3 | GROUP2 | GROUP1 | GROUP0 | xxxx | |

Legend: x = unknown value on Reset; — = unimplemented, read as '0'. Reset values are shown in hexadecimal.
Note: For reset values listed as 'xxxx', please refer to Table 4-6 for the actual reset values.

TABLE 4-11: SYSTEM BUS TARGET 3 REGISTER MAP

| Virtual Address (BF8F_#) | Register Name | Bit Range | Bits | | | | | | | | | | | | | | All Resets | |
|-----------------------------|------------------|-----------|-------------|-------|-------|-----------|-------------|-------|-----------|------|------|----------|------|------|--------|------------|---------------|--------|
| | | | 31/15 | 30/14 | 29/13 | 28/12 | 27/11 | 26/10 | 25/9 | 24/8 | 23/7 | 22/6 | 21/5 | 20/4 | 19/3 | 18/2 | | 17/1 |
| 8C20 | SBT3ELOG1 | 31:16 | MULTI | — | — | CODE<3:0> | | | | — | — | — | — | — | — | — | — | 0000 |
| | | 15:0 | INITID<7:0> | | | | REGION<3:0> | | | | — | CMD<2:0> | | | | 0000 | | |
| 8C24 | SBT3ELOG2 | 31:16 | — | — | — | — | — | — | — | — | — | — | — | — | — | — | — | 0000 |
| | | 15:0 | — | — | — | — | — | — | — | — | — | — | — | — | — | GROUP<1:0> | | 0000 |
| 8C28 | SBT3ECON | 31:16 | — | — | — | — | — | — | ERRP | — | — | — | — | — | — | — | — | 0000 |
| | | 15:0 | — | — | — | — | — | — | — | — | — | — | — | — | — | — | — | 0000 |
| 8C30 | SBT3ECLRS | 31:16 | — | — | — | — | — | — | — | — | — | — | — | — | — | — | — | 0000 |
| | | 15:0 | — | — | — | — | — | — | — | — | — | — | — | — | — | — | CLEAR | 0000 |
| 8C38 | SBT3ECLRM | 31:16 | — | — | — | — | — | — | — | — | — | — | — | — | — | — | — | 0000 |
| | | 15:0 | — | — | — | — | — | — | — | — | — | — | — | — | — | — | CLEAR | 0000 |
| 8C40 | SBT3REG0 | 31:16 | BASE<21:6> | | | | | | | | | | | | | | xxxx | |
| | | 15:0 | BASE<5:0> | | | | PRI | — | SIZE<4:0> | | | | — | — | — | — | xxxx | |
| 8C50 | SBT3RD0 | 31:16 | — | — | — | — | — | — | — | — | — | — | — | — | — | — | — | xxxx |
| | | 15:0 | — | — | — | — | — | — | — | — | — | — | — | — | GROUP3 | GROUP2 | GROUP1 | GROUP0 |
| 8C58 | SBT3WR0 | 31:16 | — | — | — | — | — | — | — | — | — | — | — | — | — | — | — | xxxx |
| | | 15:0 | — | — | — | — | — | — | — | — | — | — | — | — | GROUP3 | GROUP2 | GROUP1 | GROUP0 |
| 8C60 | SBT3REG1 | 31:16 | BASE<21:6> | | | | | | | | | | | | | | xxxx | |
| | | 15:0 | BASE<5:0> | | | | PRI | — | SIZE<4:0> | | | | — | — | — | — | xxxx | |
| 8C70 | SBT3RD1 | 31:16 | — | — | — | — | — | — | — | — | — | — | — | — | — | — | — | xxxx |
| | | 15:0 | — | — | — | — | — | — | — | — | — | — | — | — | GROUP3 | GROUP2 | GROUP1 | GROUP0 |
| 8C78 | SBT3WR1 | 31:16 | — | — | — | — | — | — | — | — | — | — | — | — | — | — | — | xxxx |
| | | 15:0 | — | — | — | — | — | — | — | — | — | — | — | — | GROUP3 | GROUP2 | GROUP1 | GROUP0 |
| 8C80 | SBT3REG2 | 31:16 | BASE<21:6> | | | | | | | | | | | | | | xxxx | |
| | | 15:0 | BASE<5:0> | | | | PRI | — | SIZE<4:0> | | | | — | — | — | — | xxxx | |
| 8C90 | SBT3RD2 | 31:16 | — | — | — | — | — | — | — | — | — | — | — | — | — | — | — | xxxx |
| | | 15:0 | — | — | — | — | — | — | — | — | — | — | — | — | GROUP3 | GROUP2 | GROUP1 | GROUP0 |
| 8C98 | SBT3WR2 | 31:16 | — | — | — | — | — | — | — | — | — | — | — | — | — | — | — | xxxx |
| | | 15:0 | — | — | — | — | — | — | — | — | — | — | — | — | GROUP3 | GROUP2 | GROUP1 | GROUP0 |

Legend: x = unknown value on Reset; — = unimplemented, read as '0'. Reset values are shown in hexadecimal.

Note: For reset values listed as 'xxxx', please refer to [Table 4-6](#) for the actual reset values.

TABLE 4-12: SYSTEM BUS TARGET 4 REGISTER MAP

| Virtual Address (BF8F_#) | Register Name | Bit Range | Bits | | | | | | | | | | | | | | All Resets | | |
|-----------------------------|---------------|-----------|-------------|-------|-------|-------|-------------|-------|-----------|------|------|----------|------|------|------------|--------|------------|--------|------|
| | | | 31/15 | 30/14 | 29/13 | 28/12 | 27/11 | 26/10 | 25/9 | 24/8 | 23/7 | 22/6 | 21/5 | 20/4 | 19/3 | 18/2 | | 17/1 | 16/0 |
| 9020 | SBT4ELOG1 | 31:16 | MULTI | — | — | — | CODE<3:0> | | | | — | — | — | — | — | — | — | — | 0000 |
| | | 15:0 | INITID<7:0> | | | | REGION<3:0> | | | | — | CMD<2:0> | | | | 0000 | | | |
| 9024 | SBT4ELOG2 | 31:16 | — | — | — | — | — | — | — | — | — | — | — | — | — | — | — | 0000 | |
| | | 15:0 | — | — | — | — | — | — | — | — | — | — | — | — | GROUP<1:0> | | | 0000 | |
| 9028 | SBT4ECON | 31:16 | — | — | — | — | — | — | ERRP | — | — | — | — | — | — | — | — | 0000 | |
| | | 15:0 | — | — | — | — | — | — | — | — | — | — | — | — | — | — | — | 0000 | |
| 9030 | SBT4ECLRS | 31:16 | — | — | — | — | — | — | — | — | — | — | — | — | — | — | — | 0000 | |
| | | 15:0 | — | — | — | — | — | — | — | — | — | — | — | — | — | — | CLEAR | 0000 | |
| 9038 | SBT4ECLRM | 31:16 | — | — | — | — | — | — | — | — | — | — | — | — | — | — | — | 0000 | |
| | | 15:0 | — | — | — | — | — | — | — | — | — | — | — | — | — | — | CLEAR | 0000 | |
| 9040 | SBT4REG0 | 31:16 | BASE<21:6> | | | | | | | | | | | | | | xxxx | | |
| | | 15:0 | BASE<5:0> | | | | PRI | — | SIZE<4:0> | | | | — | — | — | — | xxxx | | |
| 9050 | SBT4RD0 | 31:16 | — | — | — | — | — | — | — | — | — | — | — | — | — | — | — | xxxx | |
| | | 15:0 | — | — | — | — | — | — | — | — | — | — | — | — | GROUP3 | GROUP2 | GROUP1 | GROUP0 | xxxx |
| 9058 | SBT4WR0 | 31:16 | — | — | — | — | — | — | — | — | — | — | — | — | — | — | — | xxxx | |
| | | 15:0 | — | — | — | — | — | — | — | — | — | — | — | — | GROUP3 | GROUP2 | GROUP1 | GROUP0 | xxxx |
| 9080 | SBT4REG2 | 31:16 | BASE<21:6> | | | | | | | | | | | | | | xxxx | | |
| | | 15:0 | BASE<5:0> | | | | PRI | — | SIZE<4:0> | | | | — | — | — | — | xxxx | | |
| 9090 | SBT4RD2 | 31:16 | — | — | — | — | — | — | — | — | — | — | — | — | — | — | — | xxxx | |
| | | 15:0 | — | — | — | — | — | — | — | — | — | — | — | — | GROUP3 | GROUP2 | GROUP1 | GROUP0 | xxxx |
| 9098 | SBT4WR2 | 31:16 | — | — | — | — | — | — | — | — | — | — | — | — | — | — | — | xxxx | |
| | | 15:0 | — | — | — | — | — | — | — | — | — | — | — | — | GROUP3 | GROUP2 | GROUP1 | GROUP0 | xxxx |

Legend: x = unknown value on Reset; — = unimplemented, read as '0'. Reset values are shown in hexadecimal.

Note: For reset values listed as 'xxxx', please refer to [Table 4-6](#) for the actual reset values.

TABLE 4-13: SYSTEM BUS TARGET 5 REGISTER MAP

| Virtual Address (BFSF_#) | Register Name | Bit Range | Bits | | | | | | | | | | | | | | All Resets | |
|-----------------------------|------------------|-----------|-------------|-------|-------|-----------|-------------|-------|-----------|------|------|----------|------|------|--------|------------|---------------|--------|
| | | | 31/15 | 30/14 | 29/13 | 28/12 | 27/11 | 26/10 | 25/9 | 24/8 | 23/7 | 22/6 | 21/5 | 20/4 | 19/3 | 18/2 | | 17/1 |
| 9420 | SBT5ELOG1 | 31:16 | MULTI | — | — | CODE<3:0> | | | | — | — | — | — | — | — | — | — | 0000 |
| | | 15:0 | INITID<7:0> | | | | REGION<3:0> | | | | — | CMD<2:0> | | | | 0000 | | |
| 9424 | SBT5ELOG2 | 31:16 | — | — | — | — | — | — | — | — | — | — | — | — | — | — | — | 0000 |
| | | 15:0 | — | — | — | — | — | — | — | — | — | — | — | — | — | GROUP<1:0> | | 0000 |
| 9428 | SBT5ECON | 31:16 | — | — | — | — | — | — | ERRP | — | — | — | — | — | — | — | — | 0000 |
| | | 15:0 | — | — | — | — | — | — | — | — | — | — | — | — | — | — | — | 0000 |
| 9430 | SBT5ECLRS | 31:16 | — | — | — | — | — | — | — | — | — | — | — | — | — | — | — | 0000 |
| | | 15:0 | — | — | — | — | — | — | — | — | — | — | — | — | — | — | CLEAR | 0000 |
| 9438 | SBT5ECLRM | 31:16 | — | — | — | — | — | — | — | — | — | — | — | — | — | — | — | 0000 |
| | | 15:0 | — | — | — | — | — | — | — | — | — | — | — | — | — | — | CLEAR | 0000 |
| 9440 | SBT5REG0 | 31:16 | BASE<21:6> | | | | | | | | | | | | | | xxxx | |
| | | 15:0 | BASE<5:0> | | | | PRI | — | SIZE<4:0> | | | | — | — | — | — | xxxx | |
| 9450 | SBT5RD0 | 31:16 | — | — | — | — | — | — | — | — | — | — | — | — | — | — | — | xxxx |
| | | 15:0 | — | — | — | — | — | — | — | — | — | — | — | — | GROUP3 | GROUP2 | GROUP1 | GROUP0 |
| 9458 | SBT5WR0 | 31:16 | — | — | — | — | — | — | — | — | — | — | — | — | — | — | — | xxxx |
| | | 15:0 | — | — | — | — | — | — | — | — | — | — | — | — | GROUP3 | GROUP2 | GROUP1 | GROUP0 |
| 9460 | SBT5REG1 | 31:16 | BASE<21:6> | | | | | | | | | | | | | | xxxx | |
| | | 15:0 | BASE<5:0> | | | | PRI | — | SIZE<4:0> | | | | — | — | — | — | xxxx | |
| 9470 | SBT5RD1 | 31:16 | — | — | — | — | — | — | — | — | — | — | — | — | — | — | — | xxxx |
| | | 15:0 | — | — | — | — | — | — | — | — | — | — | — | — | GROUP3 | GROUP2 | GROUP1 | GROUP0 |
| 9478 | SBT5WR1 | 31:16 | — | — | — | — | — | — | — | — | — | — | — | — | — | — | — | xxxx |
| | | 15:0 | — | — | — | — | — | — | — | — | — | — | — | — | GROUP3 | GROUP2 | GROUP1 | GROUP0 |
| 9480 | SBT5REG2 | 31:16 | BASE<21:6> | | | | | | | | | | | | | | xxxx | |
| | | 15:0 | BASE<5:0> | | | | PRI | — | SIZE<4:0> | | | | — | — | — | — | xxxx | |
| 9490 | SBT5RD2 | 31:16 | — | — | — | — | — | — | — | — | — | — | — | — | — | — | — | xxxx |
| | | 15:0 | — | — | — | — | — | — | — | — | — | — | — | — | GROUP3 | GROUP2 | GROUP1 | GROUP0 |
| 9498 | SBT5WR2 | 31:16 | — | — | — | — | — | — | — | — | — | — | — | — | — | — | — | xxxx |
| | | 15:0 | — | — | — | — | — | — | — | — | — | — | — | — | GROUP3 | GROUP2 | GROUP1 | GROUP0 |

Legend: x = unknown value on Reset; — = unimplemented, read as '0'. Reset values are shown in hexadecimal.

Note: For reset values listed as 'xxxx', please refer to Table 4-6 for the actual reset values.

TABLE 4-14: SYSTEM BUS TARGET 6 REGISTER MAP

| Virtual Address (BF8F_#) | Register Name | Bit Range | Bits | | | | | | | | | | | | | | All Resets | | |
|-----------------------------|------------------|-----------|-------------|-------|-------|-------|-------------|-------|-----------|------|------|----------|------|--------|------------|--------|---------------|------|------|
| | | | 31/15 | 30/14 | 29/13 | 28/12 | 27/11 | 26/10 | 25/9 | 24/8 | 23/7 | 22/6 | 21/5 | 20/4 | 19/3 | 18/2 | | 17/1 | 16/0 |
| 9820 | SBT6ELOG1 | 31:16 | MULTI | — | — | — | CODE<3:0> | | | | — | — | — | — | — | — | — | — | 0000 |
| | | 15:0 | INITID<7:0> | | | | REGION<3:0> | | | | — | CMD<2:0> | | | | 0000 | | | |
| 9824 | SBT6ELOG2 | 31:16 | — | — | — | — | — | — | — | — | — | — | — | — | — | — | — | 0000 | |
| | | 15:0 | — | — | — | — | — | — | — | — | — | — | — | — | GROUP<1:0> | | | 0000 | |
| 9828 | SBT6ECON | 31:16 | — | — | — | — | — | — | ERRP | — | — | — | — | — | — | — | — | 0000 | |
| | | 15:0 | — | — | — | — | — | — | — | — | — | — | — | — | — | — | — | 0000 | |
| 9830 | SBT6ECLRS | 31:16 | — | — | — | — | — | — | — | — | — | — | — | — | — | — | — | 0000 | |
| | | 15:0 | — | — | — | — | — | — | — | — | — | — | — | — | — | — | CLEAR | 0000 | |
| 9838 | SBT6ECLRM | 31:16 | — | — | — | — | — | — | — | — | — | — | — | — | — | — | — | 0000 | |
| | | 15:0 | — | — | — | — | — | — | — | — | — | — | — | — | — | — | CLEAR | 0000 | |
| 9840 | SBT6REG0 | 31:16 | BASE<21:6> | | | | | | | | | | | | | | xxxx | | |
| | | 15:0 | BASE<5:0> | | | | PRI | — | SIZE<4:0> | | | | — | — | — | xxxx | | | |
| 9850 | SBT6RD0 | 31:16 | — | — | — | — | — | — | — | — | — | — | — | — | — | — | — | xxxx | |
| | | 15:0 | — | — | — | — | — | — | — | — | — | — | — | GROUP3 | GROUP2 | GROUP1 | GROUP0 | xxxx | |
| 9858 | SBT6WR0 | 31:16 | — | — | — | — | — | — | — | — | — | — | — | — | — | — | — | xxxx | |
| | | 15:0 | — | — | — | — | — | — | — | — | — | — | — | GROUP3 | GROUP2 | GROUP1 | GROUP0 | xxxx | |
| 9860 | SBT6REG1 | 31:16 | BASE<21:6> | | | | | | | | | | | | | | xxxx | | |
| | | 15:0 | BASE<5:0> | | | | PRI | — | SIZE<4:0> | | | | — | — | — | xxxx | | | |
| 9870 | SBT6RD1 | 31:16 | — | — | — | — | — | — | — | — | — | — | — | — | — | — | — | xxxx | |
| | | 15:0 | — | — | — | — | — | — | — | — | — | — | — | GROUP3 | GROUP2 | GROUP1 | GROUP0 | xxxx | |
| 9878 | SBT6WR1 | 31:16 | — | — | — | — | — | — | — | — | — | — | — | — | — | — | — | xxxx | |
| | | 15:0 | — | — | — | — | — | — | — | — | — | — | — | GROUP3 | GROUP2 | GROUP1 | GROUP0 | xxxx | |

Legend: x = unknown value on Reset; — = unimplemented, read as '0'. Reset values are shown in hexadecimal.

Note: For reset values listed as 'xxxx', please refer to [Table 4-6](#) for the actual reset values.

TABLE 4-15: SYSTEM BUS TARGET 7 REGISTER MAP

| Virtual Address (BF8F_#) | Register Name | Bit Range | Bits | | | | | | | | | | | | | | All Resets | |
|-----------------------------|------------------|-----------|-------------|-------|-------|-----------|-------------|-------|-----------|------|------|----------|------|------|------------|--------|---------------|--------|
| | | | 31/15 | 30/14 | 29/13 | 28/12 | 27/11 | 26/10 | 25/9 | 24/8 | 23/7 | 22/6 | 21/5 | 20/4 | 19/3 | 18/2 | | 17/1 |
| 9C20 | SBT7ELOG1 | 31:16 | MULTI | — | — | CODE<3:0> | | | | — | — | — | — | — | — | — | — | 0000 |
| | | 15:0 | INITID<7:0> | | | | REGION<3:0> | | | | — | CMD<2:0> | | | | 0000 | | |
| 9C24 | SBT7ELOG2 | 31:16 | — | — | — | — | — | — | — | — | — | — | — | — | — | — | — | 0000 |
| | | 15:0 | — | — | — | — | — | — | — | — | — | — | — | — | GROUP<1:0> | | | 0000 |
| 9C28 | SBT7ECON | 31:16 | — | — | — | — | — | — | ERRP | — | — | — | — | — | — | — | — | 0000 |
| | | 15:0 | — | — | — | — | — | — | — | — | — | — | — | — | — | — | — | 0000 |
| 9C30 | SBT7ECLRS | 31:16 | — | — | — | — | — | — | — | — | — | — | — | — | — | — | — | 0000 |
| | | 15:0 | — | — | — | — | — | — | — | — | — | — | — | — | — | — | CLEAR | 0000 |
| 9C38 | SBT7ECLRM | 31:16 | — | — | — | — | — | — | — | — | — | — | — | — | — | — | — | 0000 |
| | | 15:0 | — | — | — | — | — | — | — | — | — | — | — | — | — | — | CLEAR | 0000 |
| 9C40 | SBT7REG0 | 31:16 | BASE<21:6> | | | | | | | | | | | | | | xxxx | |
| | | 15:0 | BASE<5:0> | | | | PRI | — | SIZE<4:0> | | | | — | — | — | — | xxxx | |
| 9C50 | SBT7RD0 | 31:16 | — | — | — | — | — | — | — | — | — | — | — | — | — | — | — | xxxx |
| | | 15:0 | — | — | — | — | — | — | — | — | — | — | — | — | GROUP3 | GROUP2 | GROUP1 | GROUP0 |
| 9C58 | SBT7WR0 | 31:16 | — | — | — | — | — | — | — | — | — | — | — | — | — | — | — | xxxx |
| | | 15:0 | — | — | — | — | — | — | — | — | — | — | — | — | GROUP3 | GROUP2 | GROUP1 | GROUP0 |
| 9C60 | SBT7REG1 | 31:16 | BASE<21:6> | | | | | | | | | | | | | | xxxx | |
| | | 15:0 | BASE<5:0> | | | | PRI | — | SIZE<4:0> | | | | — | — | — | — | xxxx | |
| 9C70 | SBT7RD1 | 31:16 | — | — | — | — | — | — | — | — | — | — | — | — | — | — | — | xxxx |
| | | 15:0 | — | — | — | — | — | — | — | — | — | — | — | — | GROUP3 | GROUP2 | GROUP1 | GROUP0 |
| 9C78 | SBT7WR1 | 31:16 | — | — | — | — | — | — | — | — | — | — | — | — | — | — | — | xxxx |
| | | 15:0 | — | — | — | — | — | — | — | — | — | — | — | — | GROUP3 | GROUP2 | GROUP1 | GROUP0 |

Legend: x = unknown value on Reset; — = unimplemented, read as '0'. Reset values are shown in hexadecimal.

Note: For reset values listed as 'xxxx', please refer to [Table 4-6](#) for the actual reset values.

TABLE 4-16: SYSTEM BUS TARGET 8 REGISTER MAP

| Virtual Address (BF8F_#) | Register Name | Bit Range | Bits | | | | | | | | | | | | | | All Resets | | |
|-----------------------------|------------------|-----------|-------------|-------|-------|-------|-------------|-------|-----------|------|------|----------|------|--------|------------|--------|---------------|------|------|
| | | | 31/15 | 30/14 | 29/13 | 28/12 | 27/11 | 26/10 | 25/9 | 24/8 | 23/7 | 22/6 | 21/5 | 20/4 | 19/3 | 18/2 | | 17/1 | 16/0 |
| A020 | SBT8ELOG1 | 31:16 | MULTI | — | — | — | CODE<3:0> | | | | — | — | — | — | — | — | — | — | 0000 |
| | | 15:0 | INITID<7:0> | | | | REGION<3:0> | | | | — | CMD<2:0> | | | | 0000 | | | |
| A024 | SBT8ELOG2 | 31:16 | — | — | — | — | — | — | — | — | — | — | — | — | — | — | — | 0000 | |
| | | 15:0 | — | — | — | — | — | — | — | — | — | — | — | — | GROUP<1:0> | | | 0000 | |
| A028 | SBT8ECON | 31:16 | — | — | — | — | — | — | ERRP | — | — | — | — | — | — | — | — | 0000 | |
| | | 15:0 | — | — | — | — | — | — | — | — | — | — | — | — | — | — | — | 0000 | |
| A030 | SBT8ECLRS | 31:16 | — | — | — | — | — | — | — | — | — | — | — | — | — | — | — | 0000 | |
| | | 15:0 | — | — | — | — | — | — | — | — | — | — | — | — | — | — | CLEAR | 0000 | |
| A038 | SBT8ECLRM | 31:16 | — | — | — | — | — | — | — | — | — | — | — | — | — | — | — | 0000 | |
| | | 15:0 | — | — | — | — | — | — | — | — | — | — | — | — | — | — | CLEAR | 0000 | |
| A040 | SBT8REG0 | 31:16 | BASE<21:6> | | | | | | | | | | | | | | xxxx | | |
| | | 15:0 | BASE<5:0> | | | | PRI | — | SIZE<4:0> | | | | — | — | — | xxxx | | | |
| A050 | SBT8RD0 | 31:16 | — | — | — | — | — | — | — | — | — | — | — | — | — | — | — | xxxx | |
| | | 15:0 | — | — | — | — | — | — | — | — | — | — | — | GROUP3 | GROUP2 | GROUP1 | GROUP0 | xxxx | |
| A058 | SBT8WR0 | 31:16 | — | — | — | — | — | — | — | — | — | — | — | — | — | — | — | xxxx | |
| | | 15:0 | — | — | — | — | — | — | — | — | — | — | — | GROUP3 | GROUP2 | GROUP1 | GROUP0 | xxxx | |
| A060 | SBT8REG1 | 31:16 | BASE<21:6> | | | | | | | | | | | | | | xxxx | | |
| | | 15:0 | BASE<5:0> | | | | PRI | — | SIZE<4:0> | | | | — | — | — | xxxx | | | |
| A070 | SBT8RD1 | 31:16 | — | — | — | — | — | — | — | — | — | — | — | — | — | — | — | xxxx | |
| | | 15:0 | — | — | — | — | — | — | — | — | — | — | — | GROUP3 | GROUP2 | GROUP1 | GROUP0 | xxxx | |
| A078 | SBT8WR1 | 31:16 | — | — | — | — | — | — | — | — | — | — | — | — | — | — | — | xxxx | |
| | | 15:0 | — | — | — | — | — | — | — | — | — | — | — | GROUP3 | GROUP2 | GROUP1 | GROUP0 | xxxx | |

Legend: x = unknown value on Reset; — = unimplemented, read as '0'. Reset values are shown in hexadecimal.

Note: For reset values listed as 'xxxx', please refer to [Table 4-6](#) for the actual reset values.

TABLE 4-17: SYSTEM BUS TARGET 9 REGISTER MAP

| Virtual Address (BF8F_#) | Register Name | Bit Range | Bits | | | | | | | | | | | | | | All Resets | |
|-----------------------------|------------------|-----------|-------------|-------|-------|-----------|-------------|-------|-----------|------|------|----------|------|------|------------|--------|---------------|--------|
| | | | 31/15 | 30/14 | 29/13 | 28/12 | 27/11 | 26/10 | 25/9 | 24/8 | 23/7 | 22/6 | 21/5 | 20/4 | 19/3 | 18/2 | | 17/1 |
| A420 | SBT9ELOG1 | 31:16 | MULTI | — | — | CODE<3:0> | | | | — | — | — | — | — | — | — | — | 0000 |
| | | 15:0 | INITID<7:0> | | | | REGION<3:0> | | | | — | CMD<2:0> | | | | 0000 | | |
| A424 | SBT9ELOG2 | 31:16 | — | — | — | — | — | — | — | — | — | — | — | — | — | — | — | 0000 |
| | | 15:0 | — | — | — | — | — | — | — | — | — | — | — | — | GROUP<1:0> | | | 0000 |
| A428 | SBT9ECON | 31:16 | — | — | — | — | — | — | ERRP | — | — | — | — | — | — | — | — | 0000 |
| | | 15:0 | — | — | — | — | — | — | — | — | — | — | — | — | — | — | — | 0000 |
| A430 | SBT9ECLRS | 31:16 | — | — | — | — | — | — | — | — | — | — | — | — | — | — | — | 0000 |
| | | 15:0 | — | — | — | — | — | — | — | — | — | — | — | — | — | — | CLEAR | 0000 |
| A438 | SBT9ECLRM | 31:16 | — | — | — | — | — | — | — | — | — | — | — | — | — | — | — | 0000 |
| | | 15:0 | — | — | — | — | — | — | — | — | — | — | — | — | — | — | CLEAR | 0000 |
| A440 | SBT9REG0 | 31:16 | BASE<21:6> | | | | | | | | | | | | | | xxxx | |
| | | 15:0 | BASE<5:0> | | | | PRI | — | SIZE<4:0> | | | | — | — | — | — | xxxx | |
| A450 | SBT9RD0 | 31:16 | — | — | — | — | — | — | — | — | — | — | — | — | — | — | — | xxxx |
| | | 15:0 | — | — | — | — | — | — | — | — | — | — | — | — | GROUP3 | GROUP2 | GROUP1 | GROUP0 |
| A458 | SBT9WR0 | 31:16 | — | — | — | — | — | — | — | — | — | — | — | — | — | — | — | xxxx |
| | | 15:0 | — | — | — | — | — | — | — | — | — | — | — | — | GROUP3 | GROUP2 | GROUP1 | GROUP0 |
| A460 | SBT9REG1 | 31:16 | BASE<21:6> | | | | | | | | | | | | | | xxxx | |
| | | 15:0 | BASE<5:0> | | | | PRI | — | SIZE<4:0> | | | | — | — | — | — | xxxx | |
| A470 | SBT9RD1 | 31:16 | — | — | — | — | — | — | — | — | — | — | — | — | — | — | — | xxxx |
| | | 15:0 | — | — | — | — | — | — | — | — | — | — | — | — | GROUP3 | GROUP2 | GROUP1 | GROUP0 |
| A478 | SBT9WR1 | 31:16 | — | — | — | — | — | — | — | — | — | — | — | — | — | — | — | xxxx |
| | | 15:0 | — | — | — | — | — | — | — | — | — | — | — | — | GROUP3 | GROUP2 | GROUP1 | GROUP0 |

Legend: x = unknown value on Reset; — = unimplemented, read as '0'. Reset values are shown in hexadecimal.

Note: For reset values listed as 'xxxx', please refer to [Table 4-6](#) for the actual reset values.

TABLE 4-18: SYSTEM BUS TARGET 10 REGISTER MAP

| Virtual Address (BFSF_#) | Register Name | Bit Range | Bits | | | | | | | | | | | | | | All Resets | | |
|-----------------------------|------------------|-----------|-------------|-------|-------|-------|-------------|-------|-----------|------|------|----------|------|--------|------------|--------|---------------|------|------|
| | | | 31/15 | 30/14 | 29/13 | 28/12 | 27/11 | 26/10 | 25/9 | 24/8 | 23/7 | 22/6 | 21/5 | 20/4 | 19/3 | 18/2 | | 17/1 | 16/0 |
| A820 | SBT10ELOG1 | 31:16 | MULTI | — | — | — | CODE<3:0> | | | | — | — | — | — | — | — | — | — | 0000 |
| | | 15:0 | INITID<7:0> | | | | REGION<3:0> | | | | — | CMD<2:0> | | | | 0000 | | | |
| A824 | SBT10ELOG2 | 31:16 | — | — | — | — | — | — | — | — | — | — | — | — | — | — | — | 0000 | |
| | | 15:0 | — | — | — | — | — | — | — | — | — | — | — | — | GROUP<1:0> | | | 0000 | |
| A828 | SBT10ECON | 31:16 | — | — | — | — | — | — | ERRP | — | — | — | — | — | — | — | — | 0000 | |
| | | 15:0 | — | — | — | — | — | — | — | — | — | — | — | — | — | — | — | 0000 | |
| A830 | SBT10ECLRS | 31:16 | — | — | — | — | — | — | — | — | — | — | — | — | — | — | — | 0000 | |
| | | 15:0 | — | — | — | — | — | — | — | — | — | — | — | — | — | — | CLEAR | 0000 | |
| A838 | SBT10ECLRM | 31:16 | — | — | — | — | — | — | — | — | — | — | — | — | — | — | — | 0000 | |
| | | 15:0 | — | — | — | — | — | — | — | — | — | — | — | — | — | — | CLEAR | 0000 | |
| A840 | SBT10REG0 | 31:16 | BASE<21:6> | | | | | | | | | | | | | | xxxx | | |
| | | 15:0 | BASE<5:0> | | | | PRI | — | SIZE<4:0> | | | | — | — | — | xxxx | | | |
| A850 | SBT10RD0 | 31:16 | — | — | — | — | — | — | — | — | — | — | — | — | — | — | — | xxxx | |
| | | 15:0 | — | — | — | — | — | — | — | — | — | — | — | GROUP3 | GROUP2 | GROUP1 | GROUP0 | xxxx | |
| A858 | SBT10WR0 | 31:16 | — | — | — | — | — | — | — | — | — | — | — | — | — | — | — | xxxx | |
| | | 15:0 | — | — | — | — | — | — | — | — | — | — | — | GROUP3 | GROUP2 | GROUP1 | GROUP0 | xxxx | |

Legend: x = unknown value on Reset; — = unimplemented, read as '0'. Reset values are shown in hexadecimal.

Note: For reset values listed as 'xxxx', please refer to Table 4-6 for the actual reset values.

TABLE 4-19: SYSTEM BUS TARGET 11 REGISTER MAP

| Virtual Address (BFSF.#) | Register Name | Bit Range | Bits | | | | | | | | | | | | | | All Resets | |
|-----------------------------|------------------|-----------|-------------|-------|-------|-----------|-------------|-------|-----------|------|------|----------|------|------|--------|------------|---------------|--------|
| | | | 31/15 | 30/14 | 29/13 | 28/12 | 27/11 | 26/10 | 25/9 | 24/8 | 23/7 | 22/6 | 21/5 | 20/4 | 19/3 | 18/2 | | 17/1 |
| AC20 | SBT11ELOG1 | 31:16 | MULTI | — | — | CODE<3:0> | | | | — | — | — | — | — | — | — | — | 0000 |
| | | 15:0 | INITID<7:0> | | | | REGION<3:0> | | | | — | CMD<2:0> | | | | 0000 | | |
| AC24 | SBT11ELOG2 | 31:16 | — | — | — | — | — | — | — | — | — | — | — | — | — | — | — | 0000 |
| | | 15:0 | — | — | — | — | — | — | — | — | — | — | — | — | — | GROUP<1:0> | | 0000 |
| AC28 | SBT11ECON | 31:16 | — | — | — | — | — | — | ERRP | — | — | — | — | — | — | — | — | 0000 |
| | | 15:0 | — | — | — | — | — | — | — | — | — | — | — | — | — | — | — | 0000 |
| AC30 | SBT11ECLRS | 31:16 | — | — | — | — | — | — | — | — | — | — | — | — | — | — | — | 0000 |
| | | 15:0 | — | — | — | — | — | — | — | — | — | — | — | — | — | — | CLEAR | 0000 |
| AC38 | SBT11ECLRM | 31:16 | — | — | — | — | — | — | — | — | — | — | — | — | — | — | — | 0000 |
| | | 15:0 | — | — | — | — | — | — | — | — | — | — | — | — | — | — | CLEAR | 0000 |
| AC40 | SBT11REG0 | 31:16 | BASE<21:6> | | | | | | | | | | | | | | xxxx | |
| | | 15:0 | BASE<5:0> | | | | PRI | — | SIZE<4:0> | | | | — | — | — | — | xxxx | |
| AC50 | SBT11RD0 | 31:16 | — | — | — | — | — | — | — | — | — | — | — | — | — | — | — | xxxx |
| | | 15:0 | — | — | — | — | — | — | — | — | — | — | — | — | GROUP3 | GROUP2 | GROUP1 | GROUP0 |
| AC58 | SBT11WR0 | 31:16 | — | — | — | — | — | — | — | — | — | — | — | — | — | — | — | xxxx |
| | | 15:0 | — | — | — | — | — | — | — | — | — | — | — | — | GROUP3 | GROUP2 | GROUP1 | GROUP0 |
| AC60 | SBT11REG1 | 31:16 | BASE<21:6> | | | | | | | | | | | | | | xxxx | |
| | | 15:0 | BASE<5:0> | | | | PRI | — | SIZE<4:0> | | | | — | — | — | — | xxxx | |
| AC70 | SBT11RD1 | 31:16 | — | — | — | — | — | — | — | — | — | — | — | — | — | — | — | xxxx |
| | | 15:0 | — | — | — | — | — | — | — | — | — | — | — | — | GROUP3 | GROUP2 | GROUP1 | GROUP0 |
| AC78 | SBT11WR1 | 31:16 | — | — | — | — | — | — | — | — | — | — | — | — | — | — | — | xxxx |
| | | 15:0 | — | — | — | — | — | — | — | — | — | — | — | — | GROUP3 | GROUP2 | GROUP1 | GROUP0 |

Legend: x = unknown value on Reset; — = unimplemented, read as '0'. Reset values are shown in hexadecimal.

Note: For reset values listed as 'xxxx', please refer to [Table 4-6](#) for the actual reset values.

TABLE 4-20: SYSTEM BUS TARGET 12 REGISTER MAP

| Virtual Address (BF8F_#) | Register Name | Bit Range | Bits | | | | | | | | | | | | | | All Resets | |
|-----------------------------|------------------|-----------|-------------|-------|-------|-----------|-------------|-------|-----------|------|------|----------|------|------|--------|------------|---------------|--------|
| | | | 31/15 | 30/14 | 29/13 | 28/12 | 27/11 | 26/10 | 25/9 | 24/8 | 23/7 | 22/6 | 21/5 | 20/4 | 19/3 | 18/2 | | 17/1 |
| B020 | SBT12ELOG1 | 31:16 | MULTI | — | — | CODE<3:0> | | | | — | — | — | — | — | — | — | — | 0000 |
| | | 15:0 | INITID<7:0> | | | | REGION<3:0> | | | | — | CMD<2:0> | | | | 0000 | | |
| B024 | SBT12ELOG2 | 31:16 | — | — | — | — | — | — | — | — | — | — | — | — | — | — | — | 0000 |
| | | 15:0 | — | — | — | — | — | — | — | — | — | — | — | — | — | GROUP<1:0> | | 0000 |
| B028 | SBT12ECON | 31:16 | — | — | — | — | — | — | ERRP | — | — | — | — | — | — | — | — | 0000 |
| | | 15:0 | — | — | — | — | — | — | — | — | — | — | — | — | — | — | — | 0000 |
| B030 | SBT12ECLRS | 31:16 | — | — | — | — | — | — | — | — | — | — | — | — | — | — | — | 0000 |
| | | 15:0 | — | — | — | — | — | — | — | — | — | — | — | — | — | — | CLEAR | 0000 |
| B038 | SBT12ECLRM | 31:16 | — | — | — | — | — | — | — | — | — | — | — | — | — | — | — | 0000 |
| | | 15:0 | — | — | — | — | — | — | — | — | — | — | — | — | — | — | CLEAR | 0000 |
| B040 | SBT12REG0 | 31:16 | BASE<21:6> | | | | | | | | | | | | | | xxxx | |
| | | 15:0 | BASE<5:0> | | | | PRI | — | SIZE<4:0> | | | | — | — | — | — | xxxx | |
| B050 | SBT12RD0 | 31:16 | — | — | — | — | — | — | — | — | — | — | — | — | — | — | — | xxxx |
| | | 15:0 | — | — | — | — | — | — | — | — | — | — | — | — | GROUP3 | GROUP2 | GROUP1 | GROUP0 |
| B058 | SBT12WR0 | 31:16 | — | — | — | — | — | — | — | — | — | — | — | — | — | — | — | xxxx |
| | | 15:0 | — | — | — | — | — | — | — | — | — | — | — | — | GROUP3 | GROUP2 | GROUP1 | GROUP0 |

Legend: x = unknown value on Reset; — = unimplemented, read as '0'. Reset values are shown in hexadecimal.

Note: For reset values listed as 'xxxx', please refer to [Table 4-6](#) for the actual reset values.

TABLE 4-21: SYSTEM BUS TARGET 13 REGISTER MAP

| Virtual Address (BF8F_#) | Register Name | Bit Range | Bits | | | | | | | | | | | | | | All Resets | |
|-----------------------------|------------------|-----------|-------------|-------|-------|-----------|-------------|-------|------|-----------|------|----------|------|------|--------|------------|---------------|--------|
| | | | 31/15 | 30/14 | 29/13 | 28/12 | 27/11 | 26/10 | 25/9 | 24/8 | 23/7 | 22/6 | 21/5 | 20/4 | 19/3 | 18/2 | | 17/1 |
| B420 | SBT13ELOG1 | 31:16 | MULTI | — | — | CODE<3:0> | | | | — | — | — | — | — | — | — | — | 0000 |
| | | 15:0 | INITID<7:0> | | | | REGION<3:0> | | | | — | CMD<2:0> | | | | 0000 | | |
| B424 | SBT13ELOG2 | 31:16 | — | — | — | — | — | — | — | — | — | — | — | — | — | — | — | 0000 |
| | | 15:0 | — | — | — | — | — | — | — | — | — | — | — | — | — | GROUP<1:0> | | 0000 |
| B428 | SBT13ECON | 31:16 | — | — | — | — | — | — | ERRP | — | — | — | — | — | — | — | — | 0000 |
| | | 15:0 | — | — | — | — | — | — | — | — | — | — | — | — | — | — | — | 0000 |
| B430 | SBT13ECLRS | 31:16 | — | — | — | — | — | — | — | — | — | — | — | — | — | — | — | 0000 |
| | | 15:0 | — | — | — | — | — | — | — | — | — | — | — | — | — | — | CLEAR | 0000 |
| B438 | SBT13ECLRM | 31:16 | — | — | — | — | — | — | — | — | — | — | — | — | — | — | — | 0000 |
| | | 15:0 | — | — | — | — | — | — | — | — | — | — | — | — | — | — | CLEAR | 0000 |
| B440 | SBT13REG0 | 31:16 | BASE<21:6> | | | | | | | | | | | | | | xxxx | |
| | | 15:0 | BASE<5:0> | | | | | PRI | — | SIZE<4:0> | | | | — | — | — | xxxx | |
| B450 | SBT13RD0 | 31:16 | — | — | — | — | — | — | — | — | — | — | — | — | — | — | — | xxxx |
| | | 15:0 | — | — | — | — | — | — | — | — | — | — | — | — | GROUP3 | GROUP2 | GROUP1 | GROUP0 |
| B458 | SBT13WR0 | 31:16 | — | — | — | — | — | — | — | — | — | — | — | — | — | — | — | xxxx |
| | | 15:0 | — | — | — | — | — | — | — | — | — | — | — | — | GROUP3 | GROUP2 | GROUP1 | GROUP0 |

Legend: x = unknown value on Reset; — = unimplemented, read as '0'. Reset values are shown in hexadecimal.

Note: For reset values listed as 'xxxx', please refer to [Table 4-6](#) for the actual reset values.

PIC32MZ Embedded Connectivity with Floating Point Unit (EF) Family

REGISTER 4-2: SBFLAG: SYSTEM BUS STATUS FLAG REGISTER

| Bit Range | Bit 31/23/15/7 | Bit 30/22/14/6 | Bit 29/21/13/5 | Bit 28/20/12/4 | Bit 27/19/11/3 | Bit 26/18/10/2 | Bit 25/17/9/1 | Bit 24/16/8/0 |
|-----------|----------------|----------------|----------------|----------------|----------------|----------------|---------------|---------------|
| 31:24 | U-0 | U-0 | U-0 | U-0 | U-0 | U-0 | U-0 | U-0 |
| | — | — | — | — | — | — | — | — |
| 23:16 | U-0 | U-0 | U-0 | U-0 | U-0 | U-0 | U-0 | U-0 |
| | — | — | — | — | — | — | — | — |
| 15:8 | U-0 | U-0 | R-0 | R-0 | R-0 | R-0 | R-0 | R-0 |
| | — | — | T13PGV | T12PGV | T11PGV | T10PGV | T9PGV | T8PGV |
| 7:0 | R-0 | R-0 | R-0 | R-0 | R-0 | R-0 | R-0 | R-0 |
| | T7PGV | T6PGV | T5PGV | T4PGV | T3PGV | T2PGV | T1PGV | T0PGV |

Legend:

R = Readable bit W = Writable bit U = Unimplemented bit, read as '0'
 -n = Value at POR '1' = Bit is set '0' = Bit is cleared

bit 31-14 **Unimplemented:** Read as '0'

bit 13-0 **TxPGV:** Target 'x' Permission Group Violation Status bits ('x' = 0-13)

Refer to [Table 4-6](#) for the list of available targets and their descriptions.

1 = Target is reporting a Permission Group (PG) violation

0 = Target is not reporting a PG violation

Note: All errors are cleared at the source (i.e., SBTxELOG1, SBTxELOG2, SBTxECLRS, or SBTxECLRM registers).

PIC32MZ Embedded Connectivity with Floating Point Unit (EF) Family

REGISTER 4-3: SBTxELOG1: SYSTEM BUS TARGET 'x' ERROR LOG REGISTER 1 ('x' = 0-13)

| Bit Range | Bit 31/23/15/7 | Bit 30/22/14/6 | Bit 29/21/13/5 | Bit 28/20/12/4 | Bit 27/19/11/3 | Bit 26/18/10/2 | Bit 25/17/9/1 | Bit 24/16/8/0 |
|-----------|-------------------|----------------|----------------|----------------|----------------|----------------|---------------|---------------|
| 31:24 | R/W-0, C MULTI | U-0 — | U-0 — | U-0 — | R/W-0, C | R/W-0, C | R/W-0, C | R/W-0, C |
| | CODE<3:0> | | | | | | | |
| 23:16 | U-0 — | U-0 — | U-0 — | U-0 — | U-0 — | U-0 — | U-0 — | U-0 — |
| 15:8 | INITID<7:0> | | | | | | | |
| 7:0 | R-0 | R-0 | R-0 | R-0 | U-0 | R-0 | R-0 | R-0 |
| | REGION<3:0> | | | | — | CMD<2:0> | | |

| | |
|-------------------|------------------------------------|
| Legend: | C = Clearable bit |
| R = Readable bit | W = Writable bit |
| -n = Value at POR | U = Unimplemented bit, read as '0' |
| | '1' = Bit is set |
| | '0' = Bit is cleared |

bit 31 **MULTI:** Multiple Permission Violations Status bit

This bit is cleared by writing a '1'.

1 = Multiple errors have been detected

0 = No multiple errors have been detected

bit 30-28 **Unimplemented:** Read as '0'

bit 27-24 **CODE<3:0>:** Error Code bits

Indicates the type of error that was detected. These bits are cleared by writing a '1'.

1111 = Reserved

1101 = Reserved

•

•

•

0011 = Permission violation

0010 = Reserved

0001 = Reserved

0000 = No error

bit 23-16 **Unimplemented:** Read as '0'

bit 15-8 **INITID<7:0>:** Initiator ID of Requester bits

11111111 = Reserved

•

•

•

00001111 = Reserved

00001110 = Crypto Engine

00001101 = Flash Controller

00001100 = SQ11

00001011 = CAN2

00001010 = CAN1

00001001 = Ethernet Write

00001000 = Ethernet Read

00000111 = USB

00000110 = DMA Write (DMPRI (CFGCON<25>) = 1)

00000101 = DMA Write (DMPRI (CFGCON<25>) = 0)

00000100 = DMA Read (DMPRI (CFGCON<25>) = 1)

00000011 = DMA Read (DMPRI (CFGCON<25>) = 0)

00000010 = CPU (CPUPRI (CFGCON<24>) = 1)

00000001 = CPU (CPUPRI (CFGCON<25>) = 0)

00000000 = Reserved

Note: Refer to [Table 4-6](#) for the list of available targets and their descriptions.

PIC32MZ Embedded Connectivity with Floating Point Unit (EF) Family

REGISTER 4-3: SBTxELOG1: SYSTEM BUS TARGET 'x' ERROR LOG REGISTER 1 ('x' = 0-13) (CONTINUED)

- bit 7-4 **REGION<3:0>**: Requested Region Number bits
 1111 - 0000 = Target's region that reported a permission group violation
- bit 3 **Unimplemented**: Read as '0'
- bit 2-0 **CMD<2:0>**: Transaction Command of the Requester bits
 111 = Reserved
 110 = Reserved
 101 = Write (a non-posted write)
 100 = Reserved
 011 = Read (a locked read caused by a Read-Modify-Write transaction)
 010 = Read
 001 = Write
 000 = Idle

Note: Refer to [Table 4-6](#) for the list of available targets and their descriptions.

PIC32MZ Embedded Connectivity with Floating Point Unit (EF) Family

REGISTER 4-4: SBTxELOG2: SYSTEM BUS TARGET 'x' ERROR LOG REGISTER 2 ('x' = 0-13)

| Bit Range | Bit 31/23/15/7 | Bit 30/22/14/6 | Bit 29/21/13/5 | Bit 28/20/12/4 | Bit 27/19/11/3 | Bit 26/18/10/2 | Bit 25/17/9/1 | Bit 24/16/8/0 |
|-----------|----------------|----------------|----------------|----------------|----------------|----------------|---------------|---------------|
| 31:24 | U-0 | U-0 | U-0 | U-0 | U-0 | U-0 | U-0 | U-0 |
| | — | — | — | — | — | — | — | — |
| 23:16 | U-0 | U-0 | U-0 | U-0 | U-0 | U-0 | U-0 | U-0 |
| | — | — | — | — | — | — | — | — |
| 15:8 | U-0 | U-0 | U-0 | U-0 | U-0 | U-0 | U-0 | U-0 |
| | — | — | — | — | — | — | — | — |
| 7:0 | U-0 | U-0 | U-0 | U-0 | U-0 | U-0 | R-0 | R-0 |
| | — | — | — | — | — | — | GROUP<1:0> | |

Legend:

R = Readable bit W = Writable bit U = Unimplemented bit, read as '0'
 -n = Value at POR '1' = Bit is set '0' = Bit is cleared

bit 31-3 **Unimplemented:** Read as '0'
 bit 1-0 **GROUP<1:0>:** Requested Permissions Group bits
 11 = Group 3
 10 = Group 2
 01 = Group 1
 00 = Group 0

Note: Refer to [Table 4-6](#) for the list of available targets and their descriptions.

REGISTER 4-5: SBTxECON: SYSTEM BUS TARGET 'x' ERROR CONTROL REGISTER ('x' = 0-13)

| Bit Range | Bit 31/23/15/7 | Bit 30/22/14/6 | Bit 29/21/13/5 | Bit 28/20/12/4 | Bit 27/19/11/3 | Bit 26/18/10/2 | Bit 25/17/9/1 | Bit 24/16/8/0 |
|-----------|----------------|----------------|----------------|----------------|----------------|----------------|---------------|---------------|
| 31:24 | U-0 | U-0 | U-0 | U-0 | U-0 | U-0 | U-0 | R/W-0 |
| | — | — | — | — | — | — | — | ERRP |
| 23:16 | U-0 | U-0 | U-0 | U-0 | U-0 | U-0 | U-0 | U-0 |
| | — | — | — | — | — | — | — | — |
| 15:8 | U-0 | U-0 | U-0 | U-0 | U-0 | U-0 | U-0 | U-0 |
| | — | — | — | — | — | — | — | — |
| 7:0 | U-0 | U-0 | U-0 | U-0 | U-0 | U-0 | U-0 | U-0 |
| | — | — | — | — | — | — | — | — |

Legend:

R = Readable bit W = Writable bit U = Unimplemented bit, read as '0'
 -n = Value at POR '1' = Bit is set '0' = Bit is cleared

bit 31-25 **Unimplemented:** Read as '0'
 bit 24 **ERRP:** Error Control bit
 1 = Report protection group violation errors
 0 = Do not report protection group violation errors
 bit 23-0 **Unimplemented:** Read as '0'

Note: Refer to [Table 4-6](#) for the list of available targets and their descriptions.

PIC32MZ Embedded Connectivity with Floating Point Unit (EF) Family

REGISTER 4-8: SBTxREGy: SYSTEM BUS TARGET 'x' REGION 'y' REGISTER ('x' = 0-13; 'y' = 0-8)

| Bit Range | Bit 31/23/15/7 | Bit 30/22/14/6 | Bit 29/21/13/5 | Bit 28/20/12/4 | Bit 27/19/11/3 | Bit 26/18/10/2 | Bit 25/17/9/1 | Bit 24/16/8/0 |
|-------------|----------------|----------------|----------------|----------------|----------------|----------------|---------------|---------------|
| 31:24 | R/W-0 | R/W-0 | R/W-0 | R/W-0 | R/W-0 | R/W-0 | R/W-0 | R/W-0 |
| BASE<21:14> | | | | | | | | |
| 23:16 | R/W-0 | R/W-0 | R/W-0 | R/W-0 | R/W-0 | R/W-0 | R/W-0 | R/W-0 |
| BASE<13:6> | | | | | | | | |
| 15:8 | R/W-0 | R/W-0 | R/W-0 | R/W-0 | R/W-0 | R/W-0 | R-0 | U-0 |
| BASE<5:0> | | | | | | | PRI | — |
| 7:0 | R/W-0 | R/W-0 | R/W-0 | R/W-0 | R/W-0 | U-0 | U-0 | U-0 |
| SIZE<4:0> | | | | | | — | — | — |

Legend:

R = Readable bit W = Writable bit U = Unimplemented bit, read as '0'
 -n = Value at POR '1' = Bit is set '0' = Bit is cleared

bit 31-10 **BASE<21:0>**: Region Base Address bits

bit 9 **PRI**: Region Priority Level bit

1 = Level 2
 0 = Level 1

bit 8 **Unimplemented**: Read as '0'

bit 7-3 **SIZE<4:0>**: Region Size bits

Permissions for a region are only active if the SIZE is non-zero.

11111 = Region size = $2^{(SIZE-1)} \times 1024$ (bytes)

•
 •
 •

00001 = Region size = $2^{(SIZE-1)} \times 1024$ (bytes)

00000 = Region is not present

bit 2-0 **Unimplemented**: Read as '0'

Note 1: Refer to [Table 4-6](#) for the list of available targets and their descriptions.

Note 2: For some target regions, certain bits in this register are read-only with preset values. See [Table 4-6](#) for more information.

PIC32MZ Embedded Connectivity with Floating Point Unit (EF) Family

REGISTER 4-9: SBTxRDy: SYSTEM BUS TARGET 'x' REGION 'y' READ PERMISSIONS REGISTER ('x' = 0-13; 'y' = 0-8)

| Bit Range | Bit 31/23/15/7 | Bit 30/22/14/6 | Bit 29/21/13/5 | Bit 28/20/12/4 | Bit 27/19/11/3 | Bit 26/18/10/2 | Bit 25/17/9/1 | Bit 24/16/8/0 |
|-----------|----------------|----------------|----------------|----------------|----------------|----------------|---------------|---------------|
| 31:24 | U-0 | U-0 | U-0 | U-0 | U-0 | U-0 | U-0 | U-0 |
| | — | — | — | — | — | — | — | — |
| 23:16 | U-0 | U-0 | U-0 | U-0 | U-0 | U-0 | U-0 | U-0 |
| | — | — | — | — | — | — | — | — |
| 15:8 | U-0 | U-0 | U-0 | U-0 | U-0 | U-0 | U-0 | U-0 |
| | — | — | — | — | — | — | — | — |
| 7:0 | U-0 | U-0 | U-0 | U-0 | R/W-0 | R/W-1 | R/W-1 | R/W-1 |
| | — | — | — | — | GROUP3 | GROUP2 | GROUP1 | GROUP0 |

Legend:

R = Readable bit
-n = Value at POR

W = Writable bit
'1' = Bit is set

U = Unimplemented bit, read as '0'
'0' = Bit is cleared

- bit 31-4 **Unimplemented:** Read as '0'
- bit 3 **Group3:** Group3 Read Permissions bits
1 = Privilege Group 3 has read permission
0 = Privilege Group 3 does not have read permission
- bit 2 **Group2:** Group2 Read Permissions bits
1 = Privilege Group 2 has read permission
0 = Privilege Group 2 does not have read permission
- bit 1 **Group1:** Group1 Read Permissions bits
1 = Privilege Group 1 has read permission
0 = Privilege Group 1 does not have read permission
- bit 0 **Group0:** Group0 Read Permissions bits
1 = Privilege Group 0 has read permission
0 = Privilege Group 0 does not have read permission

Note 1: Refer to [Table 4-6](#) for the list of available targets and their descriptions.

Note 2: For some target regions, certain bits in this register are read-only with preset values. See [Table 4-6](#) for more information.

PIC32MZ Embedded Connectivity with Floating Point Unit (EF) Family

REGISTER 4-10: SBTxWRy: SYSTEM BUS TARGET 'x' REGION 'y' WRITE PERMISSIONS REGISTER ('x' = 0-13; 'y' = 0-8)

| Bit Range | Bit 31/23/15/7 | Bit 30/22/14/6 | Bit 29/21/13/5 | Bit 28/20/12/4 | Bit 27/19/11/3 | Bit 26/18/10/2 | Bit 25/17/9/1 | Bit 24/16/8/0 |
|-----------|----------------|----------------|----------------|----------------|----------------|----------------|---------------|---------------|
| 31:24 | U-0 | U-0 | U-0 | U-0 | U-0 | U-0 | U-0 | U-0 |
| | — | — | — | — | — | — | — | — |
| 23:16 | U-0 | U-0 | U-0 | U-0 | U-0 | U-0 | U-0 | U-0 |
| | — | — | — | — | — | — | — | — |
| 15:8 | U-0 | U-0 | U-0 | U-0 | U-0 | U-0 | U-0 | U-0 |
| | — | — | — | — | — | — | — | — |
| 7:0 | U-0 | U-0 | U-0 | U-0 | R/W-0 | R/W-1 | R/W-1 | R/W-1 |
| | — | — | — | — | GROUP3 | GROUP2 | GROUP1 | GROUP0 |

Legend:

R = Readable bit W = Writable bit U = Unimplemented bit, read as '0'
 -n = Value at POR '1' = Bit is set '0' = Bit is cleared

- bit 31-4 **Unimplemented:** Read as '0'
- bit 3 **Group3:** Group 3 Write Permissions bits
 - 1 = Privilege Group 3 has write permission
 - 0 = Privilege Group 3 does not have write permission
- bit 2 **Group2:** Group 2 Write Permissions bits
 - 1 = Privilege Group 2 has write permission
 - 0 = Privilege Group 2 does not have write permission
- bit 1 **Group1:** Group 1 Write Permissions bits
 - 1 = Privilege Group 1 has write permission
 - 0 = Privilege Group 1 does not have write permission
- bit 0 **Group0:** Group 0 Write Permissions bits
 - 1 = Privilege Group 0 has write permission
 - 0 = Privilege Group 0 does not have write permission

Note 1: Refer to [Table 4-6](#) for the list of available targets and their descriptions.
Note 2: For some target regions, certain bits in this register are read-only with preset values. See [Table 4-6](#) for more information.

5.0 FLASH PROGRAM MEMORY

Note: This data sheet summarizes the features of the PIC32MZ EF family of devices. It is not intended to be a comprehensive reference source. To complement the information in this data sheet, refer to **Section 52. “Flash Program Memory with Support for Live Update”** (DS60001193) in the “*PIC32 Family Reference Manual*”, which is available from the Microchip web site (www.microchip.com/PIC32).

PIC32MZ EF devices contain an internal Flash program memory for executing user code, which includes the following features:

- Two Flash banks for live update support
- Dual boot support
- Write protection for program and boot Flash
- ECC support

There are three methods by which the user can program this memory:

- Run-Time Self-Programming (RTSP)
- EJTAG Programming
- In-Circuit Serial Programming™ (ICSP™)

RTSP is performed by software executing from either Flash or RAM memory. Information about RTSP techniques is available in **Section 52. “Flash Program Memory with Support for Live Update”** (DS60001193) in the “*PIC32 Family Reference Manual*”.

EJTAG is performed using the EJTAG port of the device and an EJTAG capable programmer.

ICSP is performed using a serial data connection to the device and allows much faster programming times than RTSP.

The EJTAG and ICSP methods are described in the “*PIC32 Flash Programming Specification*” (DS60001145), which is available for download from the Microchip web site (www.microchip.com).

Note: In PIC32MZ EF devices, the Flash page size is 16 KB (4K IW) and the row size is 2 KB (512 IW).

5.1 Flash Control Registers

TABLE 5-1: FLASH CONTROLLER REGISTER MAP

| Virtual Address (BF80_#) | Register Name | Bit Range | Bits | | | | | | | | | | | | | | | All Resets | |
|-----------------------------|------------------------|-----------|------------------|-------|-------|--------|-------|-------|-------|-------|---------------|--------|--------|-------|-------|------------|-------|------------|------|
| | | | 31/15 | 30/14 | 29/13 | 28/12 | 27/11 | 26/10 | 25/9 | 24/8 | 23/7 | 22/6 | 21/5 | 20/4 | 19/3 | 18/2 | 17/1 | | 16/0 |
| 0600 | NVMCON ⁽¹⁾ | 31:16 | — | — | — | — | — | — | — | — | — | — | — | — | — | — | — | — | 0000 |
| | | 15:0 | WR | WREN | WRERR | LVDERR | — | — | — | — | — | PFSWAP | BFSWAP | — | — | NVMOP<3:0> | | | 00x0 |
| 0610 | NVMKEY | 31:16 | NVMKEY<31:0> | | | | | | | | | | | | | | | 0000 | |
| | | 15:0 | | | | | | | | | | | | | | | | 0000 | |
| 0620 | NVMADDR ⁽¹⁾ | 31:16 | NVMADDR<31:0> | | | | | | | | | | | | | | | 0000 | |
| | | 15:0 | | | | | | | | | | | | | | | | 0000 | |
| 0630 | NVMDATA0 | 31:16 | NVMDATA0<31:0> | | | | | | | | | | | | | | | 0000 | |
| | | 15:0 | | | | | | | | | | | | | | | | 0000 | |
| 0640 | NVMDATA1 | 31:16 | NVMDATA1<31:0> | | | | | | | | | | | | | | | 0000 | |
| | | 15:0 | | | | | | | | | | | | | | | | 0000 | |
| 0650 | NVMDATA2 | 31:16 | NVMDATA2<31:0> | | | | | | | | | | | | | | | 0000 | |
| | | 15:0 | | | | | | | | | | | | | | | | 0000 | |
| 0660 | NVMDATA3 | 31:16 | NVMDATA3<31:0> | | | | | | | | | | | | | | | 0000 | |
| | | 15:0 | | | | | | | | | | | | | | | | 0000 | |
| 0670 | NVMSRC ADDR | 31:16 | NVMSRCADDR<31:0> | | | | | | | | | | | | | | | 0000 | |
| | | 15:0 | | | | | | | | | | | | | | | | 0000 | |
| 0680 | NVMPWP ⁽¹⁾ | 31:16 | PWPLOCK | — | — | — | — | — | — | — | — | — | — | — | — | — | — | — | 8000 |
| | | 15:0 | PWP<15:0> | | | | | | | | | | | | | | | 0000 | |
| 0690 | NVMBWP ⁽¹⁾ | 31:16 | — | — | — | — | — | — | — | — | — | — | — | — | — | — | — | — | 0000 |
| | | 15:0 | LBWPLOCK | — | — | LBWP4 | LBWP3 | LBWP2 | LBWP1 | LBWP0 | UBWPLOCK | — | — | UBWP4 | UBWP3 | UBWP2 | UBWP1 | UBWP0 | 9FDF |
| 06A0 | NVMCON2 ⁽¹⁾ | 31:16 | — | — | — | — | — | — | — | — | — | — | — | — | — | — | — | — | 001F |
| | | 15:0 | — | — | — | — | — | — | — | — | SWAPLOCK<1:0> | | | — | — | — | — | — | 0000 |

Legend: x = unknown value on Reset; — = unimplemented, read as '0'. Reset values are shown in hexadecimal.

Note 1: This register has corresponding CLR, SET and INV registers at their virtual addresses, plus offsets of 0x4, 0x8 and 0xC, respectively. See [Section 12.3 “CLR, SET, and INV Registers”](#) for more information.

PIC32MZ Embedded Connectivity with Floating Point Unit (EF) Family

REGISTER 5-1: NVMCON: FLASH PROGRAMMING CONTROL REGISTER

| Bit Range | Bit 31/23/15/7 | Bit 30/22/14/6 | Bit 29/21/13/5 | Bit 28/20/12/4 | Bit 27/19/11/3 | Bit 26/18/10/2 | Bit 25/17/9/1 | Bit 24/16/8/0 |
|-----------|-------------------|---------------------|----------------------|-----------------------|----------------|----------------|---------------|---------------|
| 31:24 | U-0 | U-0 | U-0 | U-0 | U-0 | U-0 | U-0 | U-0 |
| | — | — | — | — | — | — | — | — |
| 23:16 | U-0 | U-0 | U-0 | U-0 | U-0 | U-0 | U-0 | U-0 |
| | — | — | — | — | — | — | — | — |
| 15:8 | R/W-0, HC | R/W-0 | R-0, HS, HC | R-0, HS, HC | U-0 | U-0 | U-0 | U-0 |
| | WR ⁽¹⁾ | WREN ⁽¹⁾ | WRERR ⁽¹⁾ | LVDERR ⁽¹⁾ | — | — | — | — |
| 7:0 | R/W-0 | R/W-x | U-0 | U-0 | R/W-0 | R/W-0 | R/W-0 | R/W-0 |
| | PFSWAP | BFSWAP | — | — | NVMOP<3:0> | | | |

| | | |
|-------------------|-------------------|--|
| Legend: | HC = Hardware Set | HC = Hardware Cleared |
| R = Readable bit | W = Writable bit | U = Unimplemented bit, read as '0' |
| -n = Value at POR | '1' = Bit is set | '0' = Bit is cleared x = Bit is unknown |

bit 31-16 **Unimplemented:** Read as '0'

bit 15 **WR:** Write Control bit⁽¹⁾

This bit cannot be cleared and can be set only when WREN = 1 and the unlock sequence has been performed.

- 1 = Initiate a Flash operation
- 0 = Flash operation is complete or inactive

bit 14 **WREN:** Write Enable bit⁽¹⁾

- 1 = Enable writes to the WR bit and disables writes to the NVMOP<3:0> bits
- 0 = Disable writes to WR bit and enables writes to the NVMOP<3:0> bits

bit 13 **WRERR:** Write Error bit⁽¹⁾

This bit can be cleared only by setting the NVMOP<3:0> bits = 0000 and initiating a Flash operation.

- 1 = Program or erase sequence did not complete successfully
- 0 = Program or erase sequence completed normally

bit 12 **LVDERR:** Low-Voltage Detect Error bit⁽¹⁾

This bit can be cleared only by setting the NVMOP<3:0> bits = 0000 and initiating a Flash operation.

- 1 = Low-voltage detected (possible data corruption, if WRERR is set)
- 0 = Voltage level is acceptable for programming

bit 11-8 **Unimplemented:** Read as '0'

bit 7 **PFSWAP:** Program Flash Bank Swap Control bit

This bit is only writable when WREN = 0 and the unlock sequence has been performed.

- 1 = Program Flash Bank 2 is mapped to the lower mapped region and program Flash Bank 1 is mapped to the upper mapped region
- 0 = Program Flash Bank 1 is mapped to the lower mapped region and program Flash Bank 2 is mapped to the upper mapped region

Note 1: These bits are only reset by a Power-on Reset (POR) and are not affected by other reset sources.

- 2: This operation results in a "no operation" (NOP) when the Dynamic Flash ECC Configuration bits = 00 (FECCCON<1:0> (DVCFG0<9:8>)), which enables ECC at all times. For all other FECCCON<1:0> bit settings, this command will execute, but will not write the ECC bits for the word and can cause DED errors if dynamic Flash ECC is enabled (FECCCON<1:0> = 01). Refer to **Section 52. "Flash Program Memory with Support for Live Update"** (DS60001193) for information regarding ECC and Flash programming.

PIC32MZ Embedded Connectivity with Floating Point Unit (EF) Family

REGISTER 5-1: NVMCON: FLASH PROGRAMMING CONTROL REGISTER (CONTINUED)

- bit 6 **BFSWAP**: Boot Flash Bank Alias Swap Control bit
This bit is only writable when WREN = 0 and the unlock sequence has been performed.
1 = Boot Flash Bank 2 is mapped to the lower boot alias and boot Flash Bank 1 is mapped to the upper boot alias
0 = Boot Flash Bank 1 is mapped to the lower boot alias and boot Flash Bank 2 is mapped to the upper boot alias
- bit 5-4 **Unimplemented**: Read as '0'
- bit 3-0 **NVMOP<3:0>**: NVM Operation bits
These bits are only writable when WREN = 0.
1111 = Reserved
.
.
.
1000 = Reserved
0111 = Program erase operation: erase all of program Flash memory (all pages must be unprotected, PWP<23:0> = 0x000000)
0110 = Upper program Flash memory erase operation: erases only the upper mapped region of program Flash (all pages in that region must be unprotected)
0101 = Lower program Flash memory erase operation: erases only the lower mapped region of program Flash (all pages in that region must be unprotected)
0100 = Page erase operation: erases page selected by NVMADDR, if it is not write-protected
0011 = Row program operation: programs row selected by NVMADDR, if it is not write-protected
0010 = Quad Word (128-bit) program operation: programs the 128-bit Flash word selected by NVMADDR, if it is not write-protected
0001 = Word program operation: programs word selected by NVMADDR, if it is not write-protected⁽²⁾
0000 = No operation

- Note 1:** These bits are only reset by a Power-on Reset (POR) and are not affected by other reset sources.
- 2:** This operation results in a "no operation" (NOP) when the Dynamic Flash ECC Configuration bits = 00 (FECCCON<1:0> (DVCFG0<9:8>)), which enables ECC at all times. For all other FECCCON<1:0> bit settings, this command will execute, but will not write the ECC bits for the word and can cause DED errors if dynamic Flash ECC is enabled (FECCCON<1:0> = 01). Refer to **Section 52. "Flash Program Memory with Support for Live Update"** (DS60001193) for information regarding ECC and Flash programming.

PIC32MZ Embedded Connectivity with Floating Point Unit (EF) Family

REGISTER 5-2: NVMCON2: FLASH PROGRAMMING CONTROL REGISTER 2

| Bit Range | Bit 31/23/15/7 | Bit 30/22/14/6 | Bit 29/21/13/5 | Bit 28/20/12/4 | Bit 27/19/11/3 | Bit 26/18/10/2 | Bit 25/17/9/1 | Bit 24/16/8/0 |
|-----------|----------------|----------------|----------------|----------------|----------------|----------------|---------------|---------------|
| 31:24 | U-0 | U-0 | U-0 | U-0 | U-0 | U-0 | U-0 | U-0 |
| | — | — | — | — | — | — | — | — |
| 23:16 | U-0 | U-0 | U-0 | U-0 | U-0 | U-0 | U-0 | U-0 |
| | — | — | — | — | — | — | — | — |
| 15:8 | U-0 | U-0 | U-0 | U-0 | U-0 | U-0 | U-0 | U-0 |
| | — | — | — | — | — | — | — | — |
| 7:0 | R/W-0 | R/W-0 | U-0 | U-0 | U-0 | U-0 | U-0 | U-0 |
| | SWAPLOCK<1:0> | | — | — | — | — | — | — |

| | | |
|-------------------|-------------------|--|
| Legend: | HC = Hardware Set | HC = Hardware Cleared |
| R = Readable bit | W = Writable bit | U = Unimplemented bit, read as '0' |
| -n = Value at POR | '1' = Bit is set | '0' = Bit is cleared x = Bit is unknown |

bit 31-8 **Unimplemented:** Read as '0'

bit 7-6 **SWAPLOCK<1:0>:** Flash Memory Swap Lock Control bits
 11 = PFSWAP and BFSWAP are not writable and SWAPLOCK is not writable
 10 = PFSWAP and BFSWAP are not writable and SWAPLOCK is writable
 01 = PFSWAP and BFSWAP are not writable and SWAPLOCK is writable
 00 = PFSWAP and BFSWAP are writable and SWAPLOCK is writable

bit 5-0 **Unimplemented:** Read as '0'

PIC32MZ Embedded Connectivity with Floating Point Unit (EF) Family

REGISTER 5-3: NVMKEY: PROGRAMMING UNLOCK REGISTER

| Bit Range | Bit 31/23/15/7 | Bit 30/22/14/6 | Bit 29/21/13/5 | Bit 28/20/12/4 | Bit 27/19/11/3 | Bit 26/18/10/2 | Bit 25/17/9/1 | Bit 24/16/8/0 |
|---------------|----------------|----------------|----------------|----------------|----------------|----------------|---------------|---------------|
| 31:24 | W-0 | W-0 | W-0 | W-0 | W-0 | W-0 | W-0 | W-0 |
| NVMKEY<31:24> | | | | | | | | |
| 23:16 | W-0 | W-0 | W-0 | W-0 | W-0 | W-0 | W-0 | W-0 |
| NVMKEY<23:16> | | | | | | | | |
| 15:8 | W-0 | W-0 | W-0 | W-0 | W-0 | W-0 | W-0 | W-0 |
| NVMKEY<15:8> | | | | | | | | |
| 7:0 | W-0 | W-0 | W-0 | W-0 | W-0 | W-0 | W-0 | W-0 |
| NVMKEY<7:0> | | | | | | | | |

Legend:

R = Readable bit W = Writable bit U = Unimplemented bit, read as '0'
 -n = Value at POR '1' = Bit is set '0' = Bit is cleared x = Bit is unknown

bit 31-0 **NVMKEY<31:0>**: Unlock Register bits
 These bits are write-only, and read as '0' on any read

Note: This register is used as part of the unlock sequence to prevent inadvertent writes to the PFM.

REGISTER 5-4: NVMADDR: FLASH ADDRESS REGISTER

| Bit Range | Bit 31/23/15/7 | Bit 30/22/14/6 | Bit 29/21/13/5 | Bit 28/20/12/4 | Bit 27/19/11/3 | Bit 26/18/10/2 | Bit 25/17/9/1 | Bit 24/16/8/0 |
|-------------------------------|----------------|----------------|----------------|----------------|----------------|----------------|---------------|---------------|
| 31:24 | R/W-0 | R/W-0 | R/W-0 | R/W-0 | R/W-0 | R/W-0 | R/W-0 | R/W-0 |
| NVMADDR<31:24> ⁽¹⁾ | | | | | | | | |
| 23:16 | R/W-0 | R/W-0 | R/W-0 | R/W-0 | R/W-0 | R/W-0 | R/W-0 | R/W-0 |
| NVMADDR<23:16> ⁽¹⁾ | | | | | | | | |
| 15:8 | R/W-0 | R/W-0 | R/W-0 | R/W-0 | R/W-0 | R/W-0 | R/W-0 | R/W-0 |
| NVMADDR<15:8> ⁽¹⁾ | | | | | | | | |
| 7:0 | R/W-0 | R/W-0 | R/W-0 | R/W-0 | R/W-0 | R/W-0 | R/W-0 | R/W-0 |
| NVMADDR<7:0> ⁽¹⁾ | | | | | | | | |

Legend:

R = Readable bit W = Writable bit U = Unimplemented bit, read as '0'
 -n = Value at POR '1' = Bit is set '0' = Bit is cleared x = Bit is unknown

bit 31-0 **NVMADDR<31:0>**: Flash Address bits⁽¹⁾

| NVMOP<3:0> Selection | Flash Address Bits (NVMADDR<31:0>) |
|----------------------|--|
| Page Erase | Address identifies the page to erase (NVMADDR<13:0> are ignored). |
| Row Program | Address identifies the row to program (NVMADDR<10:0> are ignored). |
| Word Program | Address identifies the word to program (NVMADDR<1:0> are ignored). |
| Quad Word Program | Address identifies the quad word (128-bit) to program (NVMADDR<3:0> bits are ignored). |

Note 1: For all other NVMOP<3:0> bit settings, the Flash address is ignored. See the NVMCON register ([Register 5-1](#)) for additional information on these bits.

Note: The bits in this register are only reset by a Power-on Reset (POR) and are not affected by other reset sources.

PIC32MZ Embedded Connectivity with Floating Point Unit (EF) Family

REGISTER 5-5: NVMDATAx: FLASH DATA REGISTER (x = 0-3)

| Bit Range | Bit 31/23/15/7 | Bit 30/22/14/6 | Bit 29/21/13/5 | Bit 28/20/12/4 | Bit 27/19/11/3 | Bit 26/18/10/2 | Bit 25/17/9/1 | Bit 24/16/8/0 |
|----------------|----------------|----------------|----------------|----------------|----------------|----------------|---------------|---------------|
| 31:24 | R/W-0 | R/W-0 | R/W-0 | R/W-0 | R/W-0 | R/W-0 | R/W-0 | R/W-0 |
| NVMDATA<31:24> | | | | | | | | |
| 23:16 | R/W-0 | R/W-0 | R/W-0 | R/W-0 | R/W-0 | R/W-0 | R/W-0 | R/W-0 |
| NVMDATA<23:16> | | | | | | | | |
| 15:8 | R/W-0 | R/W-0 | R/W-0 | R/W-0 | R/W-0 | R/W-0 | R/W-0 | R/W-0 |
| NVMDATA<15:8> | | | | | | | | |
| 7:0 | R/W-0 | R/W-0 | R/W-0 | R/W-0 | R/W-0 | R/W-0 | R/W-0 | R/W-0 |
| NVMDATA<7:0> | | | | | | | | |

Legend:

R = Readable bit W = Writable bit U = Unimplemented bit, read as '0'
 -n = Value at POR '1' = Bit is set '0' = Bit is cleared x = Bit is unknown

bit 31-0 **NVMDATA<31:0>**: Flash Data bits

Word Program: Writes NVMDATA0 to the target Flash address defined in NVMADDR

Quad Word Program: Writes NVMDATA3:NVMDATA2:NVMDATA1:NVMDATA0 to the target Flash address defined in NVMADDR. NVMDATA0 contains the Least Significant Instruction Word.

Note: The bits in this register are only reset by a Power-on Reset (POR) and are not affected by other reset sources.

REGISTER 5-6: NVMSRCADDR: SOURCE DATA ADDRESS REGISTER

| Bit Range | Bit 31/23/15/7 | Bit 30/22/14/6 | Bit 29/21/13/5 | Bit 28/20/12/4 | Bit 27/19/11/3 | Bit 26/18/10/2 | Bit 25/17/9/1 | Bit 24/16/8/0 |
|-------------------|----------------|----------------|----------------|----------------|----------------|----------------|---------------|---------------|
| 31:24 | R/W-0 | R/W-0 | R/W-0 | R/W-0 | R/W-0 | R/W-0 | R/W-0 | R/W-0 |
| NVMSRCADDR<31:24> | | | | | | | | |
| 23:16 | R/W-0 | R/W-0 | R/W-0 | R/W-0 | R/W-0 | R/W-0 | R/W-0 | R/W-0 |
| NVMSRCADDR<23:16> | | | | | | | | |
| 15:8 | R/W-0 | R/W-0 | R/W-0 | R/W-0 | R/W-0 | R/W-0 | R/W-0 | R/W-0 |
| NVMSRCADDR<15:8> | | | | | | | | |
| 7:0 | R/W-0 | R/W-0 | R/W-0 | R/W-0 | R/W-0 | R/W-0 | R/W-0 | R/W-0 |
| NVMSRCADDR<7:0> | | | | | | | | |

Legend:

R = Readable bit W = Writable bit U = Unimplemented bit, read as '0'
 -n = Value at POR '1' = Bit is set '0' = Bit is cleared x = Bit is unknown

bit 31-0 **NVMSRCADDR<31:0>**: Source Data Address bits

The system physical address of the data to be programmed into the Flash when the NVMOP<3:0> bits (NVMCON<3:0>) are set to perform row programming.

Note: The bits in this register are only reset by a Power-on Reset (POR) and are not affected by other reset sources.

PIC32MZ Embedded Connectivity with Floating Point Unit (EF) Family

REGISTER 5-7: NVMPWP: PROGRAM FLASH WRITE-PROTECT REGISTER

| Bit Range | Bit 31/23/15/7 | Bit 30/22/14/6 | Bit 29/21/13/5 | Bit 28/20/12/4 | Bit 27/19/11/3 | Bit 26/18/10/2 | Bit 25/17/9/1 | Bit 24/16/8/0 |
|-----------|----------------|----------------|----------------|----------------|----------------|----------------|---------------|---------------|
| 31:24 | R/W-1 | U-0 | U-0 | U-0 | U-0 | U-0 | U-0 | U-0 |
| | PWPUNLOCK | — | — | — | — | — | — | — |
| 23:16 | R/W-0 | R/W-0 | R/W-0 | R/W-0 | R/W-0 | R/W-0 | R/W-0 | R/W-0 |
| | PWP<23:16> | | | | | | | |
| 15:8 | R/W-0 | R/W-0 | R-0 | R-0 | R-0 | R-0 | R-0 | R-0 |
| | PWP<15:8> | | | | | | | |
| 7:0 | R-0 | R-0 | R-0 | R-0 | R-0 | R-0 | R-0 | R-0 |
| | PWP<7:0> | | | | | | | |

Legend:

R = Readable bit W = Writable bit U = Unimplemented bit, read as '0'
 -n = Value at POR '1' = Bit is set '0' = Bit is cleared x = Bit is unknown

bit 31 **PWPUNLOCK**: Program Flash Memory Page Write-protect Unlock bit

1 = Register is not locked and can be modified

0 = Register is locked and cannot be modified

This bit is only clearable and cannot be set except by any reset.

bit 30-24 **Unimplemented**: Read as '0'

bit 23-0 **PWP<23:0>**: Flash Program Write-protect (Page) Address bits

Physical memory below address 0x1Dxxxxxx is write protected, where 'xxxxxx' is specified by PWP<23:0>. When PWP<23:0> has a value of '0', write protection is disabled for the entire program Flash. If the specified address falls within the page, the entire page and all pages below the current page will be protected.

Note: The bits in this register are only writable when the NVMKEY unlock sequence is followed.

PIC32MZ Embedded Connectivity with Floating Point Unit (EF) Family

REGISTER 5-8: NVMBWP: FLASH BOOT (PAGE) WRITE-PROTECT REGISTER

| Bit Range | Bit 31/23/15/7 | Bit 30/22/14/6 | Bit 29/21/13/5 | Bit 28/20/12/4 | Bit 27/19/11/3 | Bit 26/18/10/2 | Bit 25/17/9/1 | Bit 24/16/8/0 |
|-----------|----------------|----------------|----------------|----------------------|----------------------|----------------------|----------------------|----------------------|
| 31:24 | U-0 | U-0 | U-0 | U-0 | U-0 | U-0 | U-0 | U-0 |
| | — | — | — | — | — | — | — | — |
| 23:16 | U-0 | U-0 | U-0 | U-0 | U-0 | U-0 | U-0 | U-0 |
| | — | — | — | — | — | — | — | — |
| 15:8 | R/W-1 | U-0 | U-0 | R/W-1 | R/W-1 | R/W-1 | R/W-1 | R/W-1 |
| | LBWPUNLOCK | — | — | LBWP4 ⁽¹⁾ | LBWP3 ⁽¹⁾ | LBWP2 ⁽¹⁾ | LBWP1 ⁽¹⁾ | LBWP0 ⁽¹⁾ |
| 7:0 | R/W-1 | r-1 | U-0 | R/W-1 | R/W-1 | R/W-1 | R/W-1 | R/W-1 |
| | UBWPUNLOCK | — | — | UBWP4 ⁽¹⁾ | UBWP3 ⁽¹⁾ | UBWP2 ⁽¹⁾ | UBWP1 ⁽¹⁾ | UBWP0 ⁽¹⁾ |

| | |
|-------------------|------------------------------------|
| Legend: | r = Reserved |
| R = Readable bit | W = Writable bit |
| -n = Value at POR | U = Unimplemented bit, read as '0' |
| | '1' = Bit is set |
| | '0' = Bit is cleared |
| | x = Bit is unknown |

bit 31-16 **Unimplemented:** Read as '0'

bit 15 **LBWPUNLOCK:** Lower Boot Alias Write-protect Unlock bit

1 = LBWPx bits are not locked and can be modified

0 = LBWPx bits are locked and cannot be modified

This bit is only clearable and cannot be set except by any reset.

bit 14-13 **Unimplemented:** Read as '0'

bit 12 **LBWP4:** Lower Boot Alias Page 4 Write-protect bit⁽¹⁾

1 = Write protection for physical address 0x01FC10000 through 0x1FC13FFF enabled

0 = Write protection for physical address 0x01FC10000 through 0x1FC13FFF disabled

bit 11 **LBWP3:** Lower Boot Alias Page 3 Write-protect bit⁽¹⁾

1 = Write protection for physical address 0x01FC0C000 through 0x1FC0FFFF enabled

0 = Write protection for physical address 0x01FC0C000 through 0x1FC0FFFF disabled

bit 10 **LBWP2:** Lower Boot Alias Page 2 Write-protect bit⁽¹⁾

1 = Write protection for physical address 0x01FC08000 through 0x1FC0BFFF enabled

0 = Write protection for physical address 0x01FC08000 through 0x1FC0BFFF disabled

bit 9 **LBWP1:** Lower Boot Alias Page 1 Write-protect bit⁽¹⁾

1 = Write protection for physical address 0x01FC04000 through 0x1FC07FFF enabled

0 = Write protection for physical address 0x01FC04000 through 0x1FC07FFF disabled

bit 8 **LBWP0:** Lower Boot Alias Page 0 Write-protect bit⁽¹⁾

1 = Write protection for physical address 0x01FC00000 through 0x1FC03FFF enabled

0 = Write protection for physical address 0x01FC00000 through 0x1FC03FFF disabled

bit 7 **UBWPUNLOCK:** Upper Boot Alias Write-protect Unlock bit

1 = UBWPx bits are not locked and can be modified

0 = UBWPx bits are locked and cannot be modified

This bit is only user-clearable and cannot be set except by any reset.

bit 6 **Reserved:** This bit is reserved for use by development tools

bit 5 **Unimplemented:** Read as '0'

Note 1: These bits are only available when the NVMKEY unlock sequence is performed and the associated Lock bit (LBWPUNLOCK or UBWPUNLOCK) is set.

Note: The bits in this register are only writable when the NVMKEY unlock sequence is followed.

PIC32MZ Embedded Connectivity with Floating Point Unit (EF) Family

REGISTER 5-8: NVMBWP: FLASH BOOT (PAGE) WRITE-PROTECT REGISTER

- bit 4 **UBWP4:** Upper Boot Alias Page 4 Write-protect bit⁽¹⁾
1 = Write protection for physical address 0x01FC30000 through 0x1FC33FFF enabled
0 = Write protection for physical address 0x01FC30000 through 0x1FC33FFF disabled
- bit 3 **UBWP3:** Upper Boot Alias Page 3 Write-protect bit⁽¹⁾
1 = Write protection for physical address 0x01FC2C000 through 0x1FC2FFFF enabled
0 = Write protection for physical address 0x01FC2C000 through 0x1FC2FFFF disabled
- bit 2 **UBWP2:** Upper Boot Alias Page 2 Write-protect bit⁽¹⁾
1 = Write protection for physical address 0x01FC28000 through 0x1FC2BFFF enabled
0 = Write protection for physical address 0x01FC28000 through 0x1FC2BFFF disabled
- bit 1 **UBWP1:** Upper Boot Alias Page 1 Write-protect bit⁽¹⁾
1 = Write protection for physical address 0x01FC24000 through 0x1FC27FFF enabled
0 = Write protection for physical address 0x01FC24000 through 0x1FC27FFF disabled
- bit 0 **UBWP0:** Upper Boot Alias Page 0 Write-protect bit⁽¹⁾
1 = Write protection for physical address 0x01FC20000 through 0x1FC23FFF enabled
0 = Write protection for physical address 0x01FC20000 through 0x1FC23FFF disabled

Note 1: These bits are only available when the NVMKEY unlock sequence is performed and the associated Lock bit (LBWPULOCK or UBWPULOCK) is set.

| |
|---|
| Note: The bits in this register are only writable when the NVMKEY unlock sequence is followed. |
|---|

6.0 RESETS

Note: This data sheet summarizes the features of the PIC32MZ EF family of devices. It is not intended to be a comprehensive reference source. To complement the information in this data sheet, refer to **Section 7. “Resets”** (DS60001118) in the *“PIC32 Family Reference Manual”*, which is available from the Microchip web site (www.microchip.com/PIC32).

The Reset module combines all Reset sources and controls the device Master Reset signal, SYSRST. The device Reset sources are as follows:

- Power-on Reset (POR)
- Master Clear Reset pin ($\overline{\text{MCLR}}$)
- Software Reset (SWR)
- Watchdog Timer Reset (WDTR)
- Brown-out Reset (BOR)
- Configuration Mismatch Reset (CMR)
- Deadman Timer Reset (DMTR)

A simplified block diagram of the Reset module is illustrated in [Figure 6-1](#).

FIGURE 6-1: SYSTEM RESET BLOCK DIAGRAM

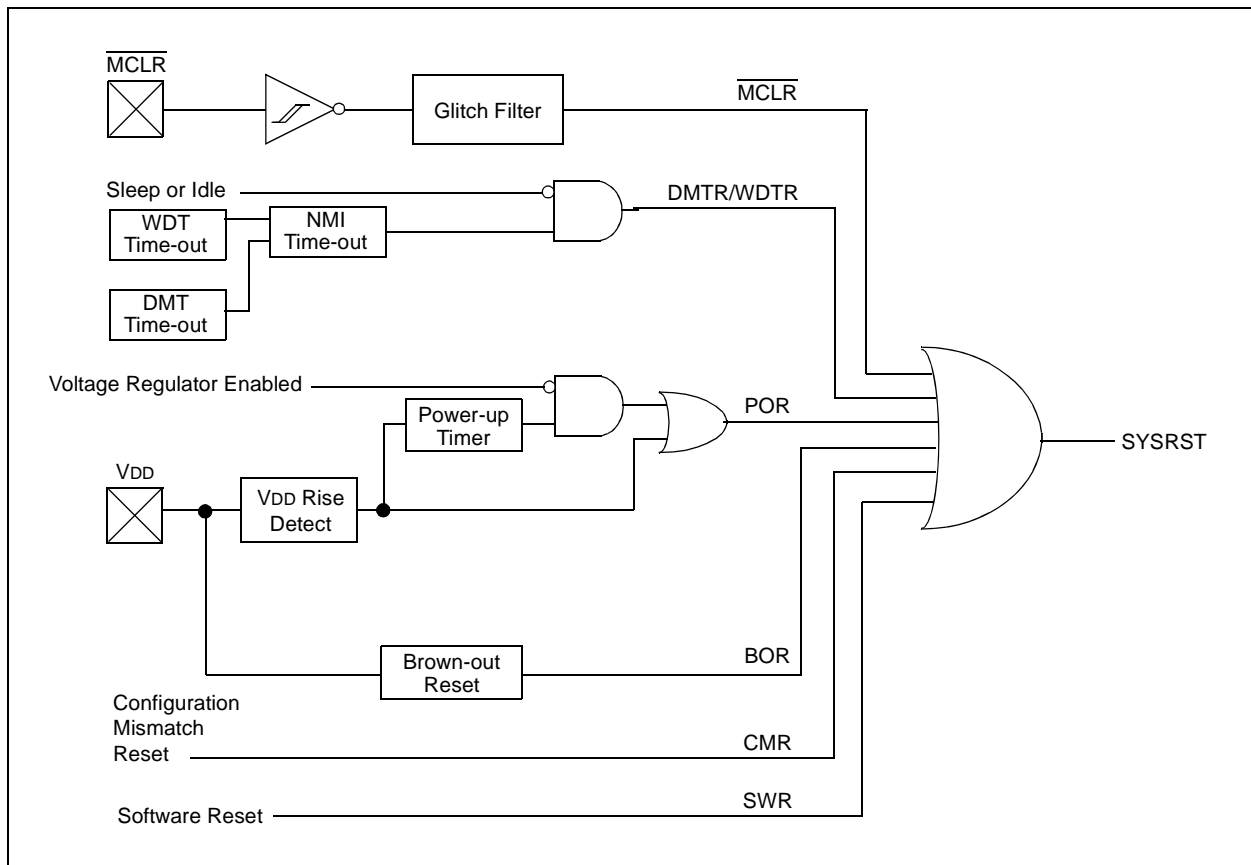

6.1 Reset Control Registers

TABLE 6-1: RESETS REGISTER MAP

| Virtual Address (BF80_#) | Register Name | Bit Range | Bits | | | | | | | | | | | | | | | | All Resets |
|-----------------------------|---------------|-----------|-----------|-------|-------|-------|---------|----------|------|------|-------|------|------|------|-------|------|------|-------|------------|
| | | | 31/15 | 30/14 | 29/13 | 28/12 | 27/11 | 26/10 | 25/9 | 24/8 | 23/7 | 22/6 | 21/5 | 20/4 | 19/3 | 18/2 | 17/1 | 16/0 | |
| 1240 | RCON | 31:16 | — | — | — | — | BCFGERR | BCFGFAIL | — | — | — | — | — | — | — | — | — | — | 0x00 |
| | | 15:0 | — | — | — | — | — | — | CMR | — | EXTR | SWR | DMTO | WDTO | SLEEP | IDLE | BOR | POR | 0003 |
| 1250 | RSWRST | 31:16 | — | — | — | — | — | — | — | — | — | — | — | — | — | — | — | — | 0000 |
| | | 15:0 | — | — | — | — | — | — | — | — | — | — | — | — | — | — | — | SWRST | 0000 |
| 1260 | RNMICON | 31:16 | — | — | — | — | — | — | DMTO | WDTO | SWNMI | — | — | — | GNMI | — | CF | WDTS | 0000 |
| | | 15:0 | NMI<15:0> | | | | | | | | | | | | | | | | 0000 |
| 1270 | PWRCON | 31:16 | — | — | — | — | — | — | — | — | — | — | — | — | — | — | — | — | 0000 |
| | | 15:0 | — | — | — | — | — | — | — | — | — | — | — | — | — | — | — | — | VREGS |

Legend: x = unknown value on Reset; — = unimplemented, read as '0'. Reset values are shown in hexadecimal.

PIC32MZ Embedded Connectivity with Floating Point Unit (EF) Family

REGISTER 6-1: RCON: RESET CONTROL REGISTER

| Bit Range | Bit 31/23/15/7 | Bit 30/22/14/6 | Bit 29/21/13/5 | Bit 28/20/12/4 | Bit 27/19/11/3 | Bit 26/18/10/2 | Bit 25/17/9/1 | Bit 24/16/8/0 |
|-----------|----------------|----------------|----------------|----------------|----------------|----------------|--------------------|--------------------|
| 31:24 | U-0 | U-0 | U-0 | U-0 | R/W-0, HS | R/W-0, HS | U-0 | U-0 |
| | — | — | — | — | BCFGERR | BCFGFAIL | — | — |
| 23:16 | U-0 | U-0 | U-0 | U-0 | U-0 | U-0 | U-0 | U-0 |
| | — | — | — | — | — | — | — | — |
| 15:8 | U-0 | U-0 | U-0 | U-0 | U-0 | U-0 | R/W-0, HS | U-0 |
| | — | — | — | — | — | — | CMR | — |
| 7:0 | R/W-0, HS | R/W-0, HS | R/W-0, HS | R/W-0, HS | R/W-0, HS | R/W-0, HS | R/W-1, HS | R/W-1, HS |
| | EXTR | SWR | DMTO | WDTO | SLEEP | IDLE | BOR ⁽¹⁾ | POR ⁽¹⁾ |

| | | |
|-------------------|-------------------|------------------------------------|
| Legend: | HS = Hardware Set | HC = Hardware Cleared |
| R = Readable bit | W = Writable bit | U = Unimplemented bit, read as '0' |
| -n = Value at POR | '1' = Bit is set | '0' = Bit is cleared |
| | | x = Bit is unknown |

- bit 31-28 **Unimplemented:** Read as '0'
- bit 27 **BCFGERR:** Primary Configuration Registers Error Flag bit
 1 = An error occurred during a read of the primary configuration registers
 0 = No error occurred during a read of the primary configuration registers
- bit 26 **BCFGFAIL:** Primary/Secondary Configuration Registers Error Flag bit
 1 = An error occurred during a read of the primary and alternate configuration registers
 0 = No error occurred during a read of the primary and alternate configuration registers
- bit 25-10 **Unimplemented:** Read as '0'
- bit 9 **CMR:** Configuration Mismatch Reset Flag bit
 1 = A Configuration Mismatch Reset has occurred
 0 = A Configuration Mismatch Reset has not occurred
- bit 8 **Unimplemented:** Read as '0'
- bit 7 **EXTR:** External Reset ($\overline{\text{MCLR}}$) Pin Flag bit
 1 = Master Clear (pin) Reset has occurred
 0 = Master Clear (pin) Reset has not occurred
- bit 6 **SWR:** Software Reset Flag bit
 1 = Software Reset was executed
 0 = Software Reset was not executed
- bit 5 **DMTO:** Deadman Timer Time-out Flag bit
 1 = A DMT time-out has occurred
 0 = A DMT time-out has not occurred
- bit 4 **WDTO:** Watchdog Timer Time-out Flag bit
 1 = WDT Time-out has occurred
 0 = WDT Time-out has not occurred
- bit 3 **SLEEP:** Wake From Sleep Flag bit
 1 = Device was in Sleep mode
 0 = Device was not in Sleep mode
- bit 2 **IDLE:** Wake From Idle Flag bit
 1 = Device was in Idle mode
 0 = Device was not in Idle mode
- bit 1 **BOR:** Brown-out Reset Flag bit⁽¹⁾
 1 = Brown-out Reset has occurred
 0 = Brown-out Reset has not occurred
- bit 0 **POR:** Power-on Reset Flag bit⁽¹⁾
 1 = Power-on Reset has occurred
 0 = Power-on Reset has not occurred

Note 1: User software must clear this bit to view the next detection.

PIC32MZ Embedded Connectivity with Floating Point Unit (EF) Family

REGISTER 6-2: RSWRST: SOFTWARE RESET REGISTER

| Bit Range | Bit 31/23/15/7 | Bit 30/22/14/6 | Bit 29/21/13/5 | Bit 28/20/12/4 | Bit 27/19/11/3 | Bit 26/18/10/2 | Bit 25/17/9/1 | Bit 24/16/8/0 |
|-----------|----------------|----------------|----------------|----------------|----------------|----------------|---------------|------------------------|
| 31:24 | U-0 | U-0 | U-0 | U-0 | U-0 | U-0 | U-0 | U-0 |
| | — | — | — | — | — | — | — | — |
| 23:16 | U-0 | U-0 | U-0 | U-0 | U-0 | U-0 | U-0 | U-0 |
| | — | — | — | — | — | — | — | — |
| 15:8 | U-0 | U-0 | U-0 | U-0 | U-0 | U-0 | U-0 | U-0 |
| | — | — | — | — | — | — | — | — |
| 7:0 | U-0 | U-0 | U-0 | U-0 | U-0 | U-0 | U-0 | W-0, HC |
| | — | — | — | — | — | — | — | SWRST ^(1,2) |

Legend:

R = Readable bit HC = Hardware Cleared
 W = Writable bit U = Unimplemented bit, read as '0'
 -n = Value at POR '1' = Bit is set '0' = Bit is cleared x = Bit is unknown

bit 31-1 **Unimplemented:** Read as '0'
 bit 0 **SWRST:** Software Reset Trigger bit^(1,2)
 1 = Enable software Reset event
 0 = No effect

- Note 1:** The system unlock sequence must be performed before the SWRST bit can be written. Refer to **Section 42. "Oscillators with Enhanced PLL"** in the *"PIC32 Family Reference Manual"* for details.
- 2:** Once this bit is set, any read of the RSWRST register will cause a reset to occur.

PIC32MZ Embedded Connectivity with Floating Point Unit (EF) Family

REGISTER 6-3: RNMICON: NON-MASKABLE INTERRUPT (NMI) CONTROL REGISTER

| Bit Range | Bit 31/23/15/7 | Bit 30/22/14/6 | Bit 29/21/13/5 | Bit 28/20/12/4 | Bit 27/19/11/3 | Bit 26/18/10/2 | Bit 25/17/9/1 | Bit 24/16/8/0 |
|-----------|----------------|----------------|----------------|----------------|----------------|----------------|---------------|---------------|
| 31:24 | U-0 | U-0 | U-0 | U-0 | U-0 | U-0 | R/W-0 | R/W-0 |
| | — | — | — | — | — | — | DMTO | WDTO |
| 23:16 | R/W-0 | U-0 | U-0 | U-0 | R/W-0 | U-0 | R/W-0 | R/W-0 |
| | SWNMI | — | — | — | GNMI | — | CF | WDT5 |
| 15:8 | R/W-0 | R/W-0 | R/W-0 | R/W-0 | R/W-0 | R/W-0 | R/W-0 | R/W-0 |
| | NMICNT<15:8> | | | | | | | |
| 7:0 | R/W-0 | R/W-0 | R/W-0 | R/W-0 | R/W-0 | R/W-0 | R/W-0 | R/W-0 |
| | NMICNT<7:0> | | | | | | | |

Legend:

R = Readable bit W = Writable bit U = Unimplemented bit, read as '0'
 -n = Value at POR '1' = Bit is set '0' = Bit is cleared x = Bit is unknown

- bit 31-26 **Unimplemented:** Read as '0'
- bit 25 **DMTO:** Deadman Timer Time-out Flag bit
 1 = DMT time-out has occurred and caused a NMI
 0 = DMT time-out has not occurred
 Setting this bit will cause a DMT NMI event, and NMICNT will begin counting.
- bit 24 **WDTO:** Watchdog Timer Time-Out Flag bit
 1 = WDT time-out has occurred and caused a NMI
 0 = WDT time-out has not occurred
 Setting this bit will cause a WDT NMI event, and NMICNT will begin counting.
- bit 23 **SWNMI:** Software NMI Trigger.
 1 = An NMI will be generated
 0 = An NMI will not be generated
- bit 22-20 **Unimplemented:** Read as '0'
- bit 19 **GNMI:** General NMI bit
 1 = A general NMI event has been detected or a user-initiated NMI event has occurred
 0 = A general NMI event has not been detected
 Setting GNMI to a '1' causes a user-initiated NMI event. This bit is also set by writing 0x4E to the NMIKEY<7:0> (INTCON<31:24>) bits.
- bit 18 **Unimplemented:** Read as '0'
- bit 17 **CF:** Clock Fail Detect bit
 1 = FSCM has detected clock failure and caused an NMI
 0 = FSCM has not detected clock failure
 Setting this bit will cause a a CF NMI event, but will not cause a clock switch to the BFRC.
- bit 16 **WDT5:** Watchdog Timer Time-out in Sleep Mode Flag bit
 1 = WDT time-out has occurred during Sleep mode and caused a wake-up from sleep
 0 = WDT time-out has not occurred during Sleep mode
 Setting this bit will cause a WDT NMI.
- bit 15-0 **NMICNT<15:0>:** NMI Reset Counter Value bits
 1111111111111111-0000000000000001 = Number of SYSCLK cycles before a device Reset occurs⁽¹⁾
 0000000000000000 = No delay between NMI assertion and device Reset event

Note 1: When a Watchdog Timer NMI event (when not in Sleep mode) or a Deadman Timer NMI event is triggered the NMICNT will start decrementing. When NMICNT reaches zero, the device is Reset. This NMI reset counter is only applicable to these two specific NMI events.

Note: The system unlock sequence must be performed before the SWRST bit can be written. Refer to **Section 42. "Oscillators with Enhanced PLL"** in the *"PIC32 Family Reference Manual"* for details.

PIC32MZ Embedded Connectivity with Floating Point Unit (EF) Family

REGISTER 6-4: PWRCON: POWER CONTROL REGISTER

| Bit Range | Bit 31/23/15/7 | Bit 30/22/14/6 | Bit 29/21/13/5 | Bit 28/20/12/4 | Bit 27/19/11/3 | Bit 26/18/10/2 | Bit 25/17/9/1 | Bit 24/16/8/0 |
|-----------|----------------|----------------|----------------|----------------|----------------|----------------|---------------|---------------|
| 31:24 | U-0 | U-0 | U-0 | U-0 | U-0 | U-0 | U-0 | U-0 |
| | — | — | — | — | — | — | — | — |
| 23:16 | U-0 | U-0 | U-0 | U-0 | U-0 | U-0 | U-0 | U-0 |
| | — | — | — | — | — | — | — | — |
| 15:8 | U-0 | U-0 | U-0 | U-0 | U-0 | U-0 | U-0 | U-0 |
| | — | — | — | — | — | — | — | — |
| 7:0 | U-0 | U-0 | U-0 | U-0 | U-0 | U-0 | U-0 | R/W-0 |
| | — | — | — | — | — | — | — | VREGS |

Legend:

R = Readable bit W = Writable bit U = Unimplemented bit, read as '0'
 -n = Value at POR '1' = Bit is set '0' = Bit is cleared x = Bit is unknown

bit 31-1 **Unimplemented:** Read as '0'

bit 0 **VREGS:** Voltage Regulator Stand-by Enable bit
 1 = Voltage regulator will remain active during Sleep
 0 = Voltage regulator will go to Stand-by mode during Sleep

7.0 CPU EXCEPTIONS AND INTERRUPT CONTROLLER

Note: This data sheet summarizes the features of the PIC32MZ EF family of devices. It is not intended to be a comprehensive reference source. To complement the information in this data sheet, refer to **Section 8. “Interrupt Controller”** (DS60001108) and **Section 50. “CPU for Devices with MIPS32® microAptiv™ and M-Class Cores”** (DS60001192) of the *“PIC32 Family Reference Manual”*, which is available from the Microchip web site (www.microchip.com/PIC32).

PIC32MZ EF devices generate interrupt requests in response to interrupt events from peripheral modules. The Interrupt Controller module exists outside of the CPU and prioritizes the interrupt events before presenting them to the CPU.

The CPU handles interrupt events as part of the exception handling mechanism, which is described in [Section 7.1 “CPU Exceptions”](#).

The Interrupt Controller module includes the following features:

- Up to 213 interrupt sources and vectors with dedicated programmable offsets, eliminating the need for redirection
- Single and multi-vector mode operations
- Five external interrupts with edge polarity control
- Interrupt proximity timer
- Seven user-selectable priority levels for each vector
- Four user-selectable subpriority levels within each priority
- Seven shadow register sets that can be used for any priority level, eliminating software context switch and reducing interrupt latency
- Software can generate any interrupt

[Figure 7-1](#) shows the block diagram for the Interrupt Controller and CPU exceptions.

FIGURE 7-1: CPU EXCEPTIONS AND INTERRUPT CONTROLLER MODULE BLOCK DIAGRAM

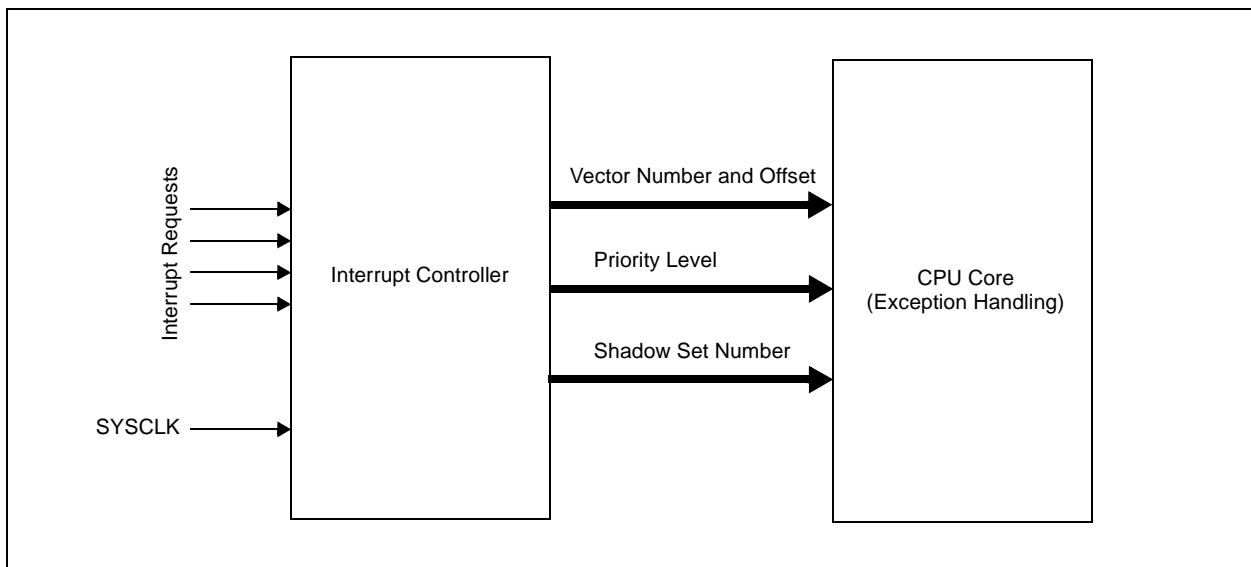

7.1 CPU Exceptions

CPU coprocessor 0 contains the logic for identifying and managing exceptions. Exceptions can be caused by a variety of sources, including boundary cases in data, external events or program errors. [Table 7-1](#) lists the exception types in order of priority.

TABLE 7-1: MIPS32® M-CLASS MICROPROCESSOR CORE EXCEPTION TYPES

| Exception Type (In Order of Priority) | Description | Branches to | Status Bits Set | Debug Bits Set | EXCCODE | XC32 Function Name |
|---|--|---------------------------------|--------------------|-------------------|---------|---------------------------------|
| Highest Priority | | | | | | |
| Reset | Assertion $\overline{\text{MCLR}}$ or a Power-on Reset (POR). | 0xBFC0_0000 | BEV, ERL | — | — | _on_reset |
| Soft Reset | Assertion of a software Reset. | 0xBFC0_0000 | BEV, SR, ERL | — | — | _on_reset |
| DSS | EJTAG debug single step. | 0xBFC0_0480 | — | DSS | — | — |
| DINT | EJTAG debug interrupt. Caused by the assertion of the external EJ_DINT input or by setting the EjtagBrk bit in the ECR register. | 0xBFC0_0480 | — | DINT | — | — |
| NMI | Assertion of NMI signal. | 0xBFC0_0000 | BEV, NMI, ERL | — | — | _nmi_handler |
| Machine Check | TLB write that conflicts with an existing entry. | EBASE+0x180 | MCHECK, EXL | — | 0x18 | _general_exception_handler |
| Interrupt | Assertion of unmasked hardware or software interrupt signal. | See Table 7-2 . | IPL<2:0> | — | 0x00 | See Table 7-2 . |
| Deferred Watch | Deferred watch (unmasked by K DM=>!(K DM) transition). | EBASE+0x180 | WP, EXL | — | 0x17 | _general_exception_handler |
| DIB | EJTAG debug hardware instruction break matched. | 0xBFC0_0480 | — | DIB | — | — |
| WATCH | A reference to an address that is in one of the Watch registers (fetch). | EBASE+0x180 | EXL | — | 0x17 | _general_exception_handler |
| AdEL | Fetch address alignment error. Fetch reference to protected address. | EBASE+0x180 | EXL | — | 0x04 | _general_exception_handler |
| TLBL | Fetch TLB miss or fetch TLB hit to page with V = 0. | EBASE if Status.EXL = 0 | — | — | 0x02 | — |
| | | EBASE+0x180 if Status.EXL == 1 | — | — | 0x02 | _general_exception_handler |
| TLBL Execute Inhibit | An instruction fetch matched a valid TLB entry that had the XI bit set. | EBASE+0x180 | EXL | — | 0x14 | _general_exception_handler |
| Cache Error | Instruction or data reference detects a cache tag or data error. | EBASE+0x100 | — | — | 0x1E | _cache_error_exception |

TABLE 7-1: MIPS32® M-CLASS MICROPROCESSOR CORE EXCEPTION TYPES (CONTINUED)

| Exception Type (In Order of Priority) | Description | Branches to | Status Bits Set | Debug Bits Set | EXCCODE | XC32 Function Name |
|---|--|-------------|--------------------|---|-----------------|----------------------------|
| IBE | Instruction fetch bus error. | EBASE+0x180 | EXL | — | 0x06 | _general_exception_handler |
| Instruction Validity Exceptions | An instruction could not be completed because it was not allowed to access the required resources (Coprocessor Unusable) or was illegal (Reserved Instruction). If both exceptions occur on the same instruction, the Coprocessor Unusable Exception takes priority over the Reserved Instruction Exception. | EBASE+0x180 | EXL | — | 0x0A or 0x0B | _general_exception_handler |
| Execute Exception | An instruction-based exception occurred: Integer overflow, trap, system call, breakpoint, floating point, or DSP ASE state disabled exception. | EBASE+0x180 | EXL | — | 0x08-0x0C | _general_exception_handler |
| Tr | Execution of a trap (when trap condition is true). | EBASE+0x180 | EXL | — | 0x0D | _general_exception_handler |
| DDBL/DDBS | EJTAG Data Address Break (address only) or EJTAG data value break on store (address + value). | 0xBFC0_0480 | — | DDBL or DDBS | — | — |
| WATCH | A reference to an address that is in one of the Watch registers (data). | EBASE+0x180 | EXL | — | 0x17 | _general_exception_handler |
| AdEL | Load address alignment error. User mode load reference to kernel address. | EBASE+0x180 | EXL | — | 0x04 | _general_exception_handler |
| AdES | Store address alignment error. User mode store to kernel address. | EBASE+0x180 | EXL | — | 0x05 | _general_exception_handler |
| TLBL | Load TLB miss or load TLB hit to page with V = 0. | EBASE+0x180 | EXL | — | 0x02 | _general_exception_handler |
| TLBS | Store TLB miss or store TLB hit to page with V = 0. | EBASE+0x180 | EXL | — | 0x03 | _general_exception_handler |
| DBE | Load or store bus error. | EBASE+0x180 | EXL | — | 0x07 | _general_exception_handler |
| DDBL | EJTAG data hardware breakpoint matched in load data compare. | 0xBFC0_0480 | — | DDBL | — | — |
| CBrk | EJTAG complex breakpoint. | 0xBFC0_0480 | — | DIBIMPR, DDBLIMPR, and/or DDBSIMPR | — | — |
| Lowest Priority | | | | | | |

7.2 Interrupts

The PIC32MZ EF family uses variable offsets for vector spacing. This allows the interrupt vector spacing to be configured according to application needs. A unique interrupt vector offset can be set for each vector using its associated OFFx register.

For details on the Variable Offset feature, refer to **8.5.2 “Variable Offset”** in **Section 8. “Interrupt Controller”** (DS60001108) of the *“PIC32 Family Reference Manual”*.

[Table 7-2](#) provides the Interrupt IRQ, vector and bit location information.

TABLE 7-2: INTERRUPT IRQ, VECTOR, AND BIT LOCATION

| Interrupt Source ⁽¹⁾ | XC32 Vector Name | IRQ # | Vector # | Interrupt Bit Location | | | | Persistent Interrupt |
|---------------------------------|-------------------------------|-------|--------------|------------------------|----------|-------------|--------------|----------------------|
| | | | | Flag | Enable | Priority | Sub-priority | |
| Highest Natural Order Priority | | | | | | | | |
| Core Timer Interrupt | _CORE_TIMER_VECTOR | 0 | OFF000<17:1> | IFS0<0> | IEC0<0> | IPC0<4:2> | IPC0<1:0> | No |
| Core Software Interrupt 0 | _CORE_SOFTWARE_0_VECTOR | 1 | OFF001<17:1> | IFS0<1> | IEC0<1> | IPC0<12:10> | IPC0<9:8> | No |
| Core Software Interrupt 1 | _CORE_SOFTWARE_1_VECTOR | 2 | OFF002<17:1> | IFS0<2> | IEC0<2> | IPC0<20:18> | IPC0<17:16> | No |
| External Interrupt | _EXTERNAL_0_VECTOR | 3 | OFF003<17:1> | IFS0<3> | IEC0<3> | IPC0<28:26> | IPC0<25:24> | No |
| Timer1 | _TIMER_1_VECTOR | 4 | OFF004<17:1> | IFS0<4> | IEC0<4> | IPC1<4:2> | IPC1<1:0> | No |
| Input Capture 1 Error | _INPUT_CAPTURE_1_ERROR_VECTOR | 5 | OFF005<17:1> | IFS0<5> | IEC0<5> | IPC1<12:10> | IPC1<9:8> | Yes |
| Input Capture 1 | _INPUT_CAPTURE_1_VECTOR | 6 | OFF006<17:1> | IFS0<6> | IEC0<6> | IPC1<20:18> | IPC1<17:16> | Yes |
| Output Compare 1 | _OUTPUT_COMPARE_1_VECTOR | 7 | OFF007<17:1> | IFS0<7> | IEC0<7> | IPC1<28:26> | IPC1<25:24> | No |
| External Interrupt 1 | _EXTERNAL_1_VECTOR | 8 | OFF008<17:1> | IFS0<8> | IEC0<8> | IPC2<4:2> | IPC2<1:0> | No |
| Timer2 | _TIMER_2_VECTOR | 9 | OFF009<17:1> | IFS0<9> | IEC0<9> | IPC2<12:10> | IPC2<9:8> | No |
| Input Capture 2 Error | _INPUT_CAPTURE_2_ERROR_VECTOR | 10 | OFF010<17:1> | IFS0<10> | IEC0<10> | IPC2<20:18> | IPC2<17:16> | Yes |
| Input Capture 2 | _INPUT_CAPTURE_2_VECTOR | 11 | OFF011<17:1> | IFS0<11> | IEC0<11> | IPC2<28:26> | IPC2<25:24> | Yes |
| Output Compare 2 | _OUTPUT_COMPARE_2_VECTOR | 12 | OFF012<17:1> | IFS0<12> | IEC0<12> | IPC3<4:2> | IPC3<1:0> | No |
| External Interrupt 2 | _EXTERNAL_2_VECTOR | 13 | OFF013<17:1> | IFS0<13> | IEC0<13> | IPC3<12:10> | IPC3<9:8> | No |
| Timer3 | _TIMER_3_VECTOR | 14 | OFF014<17:1> | IFS0<14> | IEC0<14> | IPC3<20:18> | IPC3<17:16> | No |
| Input Capture 3 Error | _INPUT_CAPTURE_3_ERROR_VECTOR | 15 | OFF015<17:1> | IFS0<15> | IEC0<15> | IPC3<28:26> | IPC3<25:24> | Yes |
| Input Capture 3 | _INPUT_CAPTURE_3_VECTOR | 16 | OFF016<17:1> | IFS0<16> | IEC0<16> | IPC4<4:2> | IPC4<1:0> | Yes |
| Output Compare 3 | _OUTPUT_COMPARE_3_VECTOR | 17 | OFF017<17:1> | IFS0<17> | IEC0<17> | IPC4<12:10> | IPC4<9:8> | No |
| External Interrupt 3 | _EXTERNAL_3_VECTOR | 18 | OFF018<17:1> | IFS0<18> | IEC0<18> | IPC4<20:18> | IPC4<17:16> | No |
| Timer4 | _TIMER_4_VECTOR | 19 | OFF019<17:1> | IFS0<19> | IEC0<19> | IPC4<28:26> | IPC4<25:24> | No |
| Input Capture 4 Error | _INPUT_CAPTURE_4_ERROR_VECTOR | 20 | OFF020<17:1> | IFS0<20> | IEC0<20> | IPC5<4:2> | IPC5<1:0> | Yes |
| Input Capture 4 | _INPUT_CAPTURE_4_VECTOR | 21 | OFF021<17:1> | IFS0<21> | IEC0<21> | IPC5<12:10> | IPC5<9:8> | Yes |

- Note 1:** Not all interrupt sources are available on all devices. See [TABLE 1: “PIC32MZ EF Family Features”](#) for the list of available peripherals.
- Note 2:** This interrupt source is not available on 64-pin devices.
- Note 3:** This interrupt source is not available on 100-pin devices.
- Note 4:** This interrupt source is not available on 124-pin devices.

TABLE 7-2: INTERRUPT IRQ, VECTOR, AND BIT LOCATION (CONTINUED)

| Interrupt Source ⁽¹⁾ | XC32 Vector Name | IRQ # | Vector # | Interrupt Bit Location | | | | Persistent Interrupt |
|---------------------------------|-------------------------------|-------|--------------|------------------------|----------|--------------|--------------|----------------------|
| | | | | Flag | Enable | Priority | Sub-priority | |
| Output Compare 4 | _OUTPUT_COMPARE_4_VECTOR | 22 | OFF022<17:1> | IFS0<22> | IEC0<22> | IPC5<20:18> | IPC5<17:16> | No |
| External Interrupt 4 | _EXTERNAL_4_VECTOR | 23 | OFF023<17:1> | IFS0<23> | IEC0<23> | IPC5<28:26> | IPC5<25:24> | No |
| Timer5 | _TIMER_5_VECTOR | 24 | OFF024<17:1> | IFS0<24> | IEC0<24> | IPC6<4:2> | IPC6<1:0> | No |
| Input Capture 5 Error | _INPUT_CAPTURE_5_ERROR_VECTOR | 25 | OFF025<17:1> | IFS0<25> | IEC0<25> | IPC6<12:10> | IPC6<9:8> | Yes |
| Input Capture 5 | _INPUT_CAPTURE_5_VECTOR | 26 | OFF026<17:1> | IFS0<26> | IEC0<26> | IPC6<20:18> | IPC6<17:16> | Yes |
| Output Compare 5 | _OUTPUT_COMPARE_5_VECTOR | 27 | OFF027<17:1> | IFS0<27> | IEC0<27> | IPC6<28:26> | IPC6<25:24> | No |
| Timer6 | _TIMER_6_VECTOR | 28 | OFF028<17:1> | IFS0<28> | IEC0<28> | IPC7<4:2> | IPC7<1:0> | No |
| Input Capture 6 Error | _INPUT_CAPTURE_6_ERROR_VECTOR | 29 | OFF029<17:1> | IFS0<29> | IEC0<29> | IPC7<12:10> | IPC7<9:8> | Yes |
| Input Capture 6 | _INPUT_CAPTURE_6_VECTOR | 30 | OFF030<17:1> | IFS0<30> | IEC0<30> | IPC7<20:18> | IPC7<17:16> | Yes |
| Output Compare 6 | _OUTPUT_COMPARE_6_VECTOR | 31 | OFF031<17:1> | IFS0<31> | IEC0<31> | IPC7<28:26> | IPC7<25:24> | No |
| Timer7 | _TIMER_7_VECTOR | 32 | OFF032<17:1> | IFS1<0> | IEC1<0> | IPC8<4:2> | IPC8<1:0> | No |
| Input Capture 7 Error | _INPUT_CAPTURE_7_ERROR_VECTOR | 33 | OFF033<17:1> | IFS1<1> | IEC1<1> | IPC8<12:10> | IPC8<9:8> | Yes |
| Input Capture 7 | _INPUT_CAPTURE_7_VECTOR | 34 | OFF034<17:1> | IFS1<2> | IEC1<2> | IPC8<20:18> | IPC8<17:16> | Yes |
| Output Compare 7 | _OUTPUT_COMPARE_7_VECTOR | 35 | OFF035<17:1> | IFS1<3> | IEC1<3> | IPC8<28:26> | IPC8<25:24> | No |
| Timer8 | _TIMER_8_VECTOR | 36 | OFF036<17:1> | IFS1<4> | IEC1<4> | IPC9<4:2> | IPC9<1:0> | No |
| Input Capture 8 Error | _INPUT_CAPTURE_8_ERROR_VECTOR | 37 | OFF037<17:1> | IFS1<5> | IEC1<5> | IPC9<12:10> | IPC9<9:8> | Yes |
| Input Capture 8 | _INPUT_CAPTURE_8_VECTOR | 38 | OFF038<17:1> | IFS1<6> | IEC1<6> | IPC9<20:18> | IPC9<17:16> | Yes |
| Output Compare 8 | _OUTPUT_COMPARE_8_VECTOR | 39 | OFF039<17:1> | IFS1<7> | IEC1<7> | IPC9<28:26> | IPC9<25:24> | No |
| Timer9 | _TIMER_9_VECTOR | 40 | OFF040<17:1> | IFS1<8> | IEC1<8> | IPC10<4:2> | IPC10<1:0> | No |
| Input Capture 9 Error | _INPUT_CAPTURE_9_ERROR_VECTOR | 41 | OFF041<17:1> | IFS1<9> | IEC1<9> | IPC10<12:10> | IPC10<9:8> | Yes |
| Input Capture 9 | _INPUT_CAPTURE_9_VECTOR | 42 | OFF042<17:1> | IFS1<10> | IEC1<10> | IPC10<20:18> | IPC10<17:16> | Yes |
| Output Compare 9 | _OUTPUT_COMPARE_9_VECTOR | 43 | OFF043<17:1> | IFS1<11> | IEC1<11> | IPC10<28:26> | IPC10<25:24> | No |
| ADC Global Interrupt | _ADC_VECTOR | 44 | OFF044<17:1> | IFS1<12> | IEC1<12> | IPC11<4:2> | IPC11<1:0> | Yes |
| ADC FIFO Data Ready Interrupt | _ADC_FIFO_VECTOR | 45 | OFF045<17:1> | IFS1<13> | IEC1<13> | IPC11<12:10> | IPC11<9:8> | Yes |
| ADC Digital Comparator 1 | _ADC_DC1_VECTOR | 46 | OFF046<17:1> | IFS1<14> | IEC1<14> | IPC11<20:18> | IPC11<17:16> | Yes |
| ADC Digital Comparator 2 | _ADC_DC2_VECTOR | 47 | OFF047<17:1> | IFS1<15> | IEC1<15> | IPC11<28:26> | IPC11<25:24> | Yes |
| ADC Digital Comparator 3 | _ADC_DC3_VECTOR | 48 | OFF048<17:1> | IFS1<16> | IEC1<16> | IPC12<4:2> | IPC12<1:0> | Yes |
| ADC Digital Comparator 4 | _ADC_DC4_VECTOR | 49 | OFF049<17:1> | IFS1<17> | IEC1<17> | IPC12<12:10> | IPC12<9:8> | Yes |

Note 1: Not all interrupt sources are available on all devices. See [TABLE 1: "PIC32MZ EF Family Features"](#) for the list of available peripherals.

- 2:** This interrupt source is not available on 64-pin devices.
3: This interrupt source is not available on 100-pin devices.
4: This interrupt source is not available on 124-pin devices.

TABLE 7-2: INTERRUPT IRQ, VECTOR, AND BIT LOCATION (CONTINUED)

| Interrupt Source ⁽¹⁾ | XC32 Vector Name | IRQ # | Vector # | Interrupt Bit Location | | | | Persistent Interrupt |
|---------------------------------|--------------------|-------|--------------|------------------------|----------|--------------|--------------|----------------------|
| | | | | Flag | Enable | Priority | Sub-priority | |
| ADC Digital Comparator 5 | _ADC_DC5_VECTOR | 50 | OFF050<17:1> | IFS1<18> | IEC1<18> | IPC12<20:18> | IPC12<17:16> | Yes |
| ADC Digital Comparator 6 | _ADC_DC6_VECTOR | 51 | OFF051<17:1> | IFS1<19> | IEC1<19> | IPC12<28:26> | IPC12<25:24> | Yes |
| ADC Digital Filter 1 | _ADC_DF1_VECTOR | 52 | OFF052<17:1> | IFS1<20> | IEC1<20> | IPC13<4:2> | IPC13<1:0> | Yes |
| ADC Digital Filter 2 | _ADC_DF2_VECTOR | 53 | OFF053<17:1> | IFS1<21> | IEC1<21> | IPC13<12:10> | IPC13<9:8> | Yes |
| ADC Digital Filter 3 | _ADC_DF3_VECTOR | 54 | OFF054<17:1> | IFS1<22> | IEC1<22> | IPC13<20:18> | IPC13<17:16> | Yes |
| ADC Digital Filter 4 | _ADC_DF4_VECTOR | 55 | OFF055<17:1> | IFS1<23> | IEC1<23> | IPC13<28:26> | IPC13<25:24> | Yes |
| ADC Digital Filter 5 | _ADC_DF5_VECTOR | 56 | OFF056<17:1> | IFS1<24> | IEC1<24> | IPC14<4:2> | IPC14<1:0> | Yes |
| ADC Digital Filter 6 | _ADC_DF6_VECTOR | 57 | OFF057<17:1> | IFS1<25> | IEC1<25> | IPC14<12:10> | IPC14<9:8> | Yes |
| ADC Fault | _ADC_FAULT_VECTOR | 58 | OFF058<17:1> | IFS1<26> | IEC1<26> | IPC14<20:18> | IPC14<17:16> | No |
| ADC Data 0 | _ADC_DATA0_VECTOR | 59 | OFF059<17:1> | IFS1<27> | IEC1<27> | IPC14<28:26> | IPC14<25:24> | Yes |
| ADC Data 1 | _ADC_DATA1_VECTOR | 60 | OFF060<17:1> | IFS1<28> | IEC1<28> | IPC15<4:2> | IPC15<1:0> | Yes |
| ADC Data 2 | _ADC_DATA2_VECTOR | 61 | OFF061<17:1> | IFS1<29> | IEC1<29> | IPC15<12:10> | IPC15<9:8> | Yes |
| ADC Data 3 | _ADC_DATA3_VECTOR | 62 | OFF062<17:1> | IFS1<30> | IEC1<30> | IPC15<20:18> | IPC15<17:16> | Yes |
| ADC Data 4 | _ADC_DATA4_VECTOR | 63 | OFF063<17:1> | IFS1<31> | IEC1<31> | IPC15<28:26> | IPC15<25:24> | Yes |
| ADC Data 5 | _ADC_DATA5_VECTOR | 64 | OFF064<17:1> | IFS2<0> | IEC2<0> | IPC16<4:2> | IPC16<1:0> | Yes |
| ADC Data 6 | _ADC_DATA6_VECTOR | 65 | OFF065<17:1> | IFS2<1> | IEC2<1> | IPC16<12:10> | IPC16<9:8> | Yes |
| ADC Data 7 | _ADC_DATA7_VECTOR | 66 | OFF066<17:1> | IFS2<2> | IEC2<2> | IPC16<20:18> | IPC16<17:16> | Yes |
| ADC Data 8 | _ADC_DATA8_VECTOR | 67 | OFF067<17:1> | IFS2<3> | IEC2<3> | IPC16<28:26> | IPC16<25:24> | Yes |
| ADC Data 9 | _ADC_DATA9_VECTOR | 68 | OFF068<17:1> | IFS2<4> | IEC2<4> | IPC17<4:2> | IPC17<1:0> | Yes |
| ADC Data 10 | _ADC_DATA10_VECTOR | 69 | OFF069<17:1> | IFS2<5> | IEC2<5> | IPC17<12:10> | IPC17<9:8> | Yes |
| ADC Data 11 | _ADC_DATA11_VECTOR | 70 | OFF070<17:1> | IFS2<6> | IEC2<6> | IPC17<20:18> | IPC17<17:16> | Yes |
| ADC Data 12 | _ADC_DATA12_VECTOR | 71 | OFF071<17:1> | IFS2<7> | IEC2<7> | IPC17<28:26> | IPC17<25:24> | Yes |
| ADC Data 13 | _ADC_DATA13_VECTOR | 72 | OFF072<17:1> | IFS2<8> | IEC2<8> | IPC18<4:2> | IPC18<1:0> | Yes |
| ADC Data 14 | _ADC_DATA14_VECTOR | 73 | OFF073<17:1> | IFS2<9> | IEC2<9> | IPC18<12:10> | IPC18<9:8> | Yes |
| ADC Data 15 | _ADC_DATA15_VECTOR | 74 | OFF074<17:1> | IFS2<10> | IEC2<10> | IPC18<20:18> | IPC18<17:16> | Yes |
| ADC Data 16 | _ADC_DATA16_VECTOR | 75 | OFF075<17:1> | IFS2<11> | IEC2<11> | IPC18<28:26> | IPC18<25:24> | Yes |
| ADC Data 17 | _ADC_DATA17_VECTOR | 76 | OFF076<17:1> | IFS2<12> | IEC2<12> | IPC19<4:2> | IPC19<1:0> | Yes |
| ADC Data 18 | _ADC_DATA18_VECTOR | 77 | OFF077<17:1> | IFS2<13> | IEC2<13> | IPC19<12:10> | IPC19<9:8> | Yes |

Note 1: Not all interrupt sources are available on all devices. See [TABLE 1: "PIC32MZ EF Family Features"](#) for the list of available peripherals.

- 2:** This interrupt source is not available on 64-pin devices.
3: This interrupt source is not available on 100-pin devices.
4: This interrupt source is not available on 124-pin devices.

TABLE 7-2: INTERRUPT IRQ, VECTOR, AND BIT LOCATION (CONTINUED)

| Interrupt Source ⁽¹⁾ | XC32 Vector Name | IRQ # | Vector # | Interrupt Bit Location | | | | Persistent Interrupt |
|------------------------------------|------------------------------|-------|--------------|------------------------|----------|--------------|--------------|----------------------|
| | | | | Flag | Enable | Priority | Sub-priority | |
| ADC Data 19 ⁽²⁾ | _ADC_DATA19_VECTOR | 78 | OFF078<17:1> | IFS2<14> | IEC2<14> | IPC19<20:18> | IPC19<17:16> | Yes |
| ADC Data 20 ⁽²⁾ | _ADC_DATA20_VECTOR | 79 | OFF079<17:1> | IFS2<15> | IEC2<15> | IPC19<28:26> | IPC19<25:24> | Yes |
| ADC Data 21 ⁽²⁾ | _ADC_DATA21_VECTOR | 80 | OFF080<17:1> | IFS2<16> | IEC2<16> | IPC20<4:2> | IPC20<1:0> | Yes |
| ADC Data 22 ⁽²⁾ | _ADC_DATA22_VECTOR | 81 | OFF081<17:1> | IFS2<17> | IEC2<17> | IPC20<12:10> | IPC20<9:8> | Yes |
| ADC Data 23 ⁽²⁾ | _ADC_DATA23_VECTOR | 82 | OFF082<17:1> | IFS2<18> | IEC2<18> | IPC20<20:18> | IPC20<17:16> | Yes |
| ADC Data 24 ⁽²⁾ | _ADC_DATA24_VECTOR | 83 | OFF083<17:1> | IFS2<19> | IEC2<19> | IPC20<28:26> | IPC20<25:24> | Yes |
| ADC Data 25 ⁽²⁾ | _ADC_DATA25_VECTOR | 84 | OFF084<17:1> | IFS2<20> | IEC2<20> | IPC21<4:2> | IPC21<1:0> | Yes |
| ADC Data 26 ⁽²⁾ | _ADC_DATA26_VECTOR | 85 | OFF085<17:1> | IFS2<21> | IEC2<21> | IPC21<12:10> | IPC21<9:8> | Yes |
| ADC Data 27 ⁽²⁾ | _ADC_DATA27_VECTOR | 86 | OFF086<17:1> | IFS2<22> | IEC2<22> | IPC21<20:18> | IPC21<17:16> | Yes |
| ADC Data 28 ⁽²⁾ | _ADC_DATA28_VECTOR | 87 | OFF087<17:1> | IFS2<23> | IEC2<23> | IPC21<28:26> | IPC21<25:24> | Yes |
| ADC Data 29 ⁽²⁾ | _ADC_DATA29_VECTOR | 88 | OFF088<17:1> | IFS2<24> | IEC2<24> | IPC22<4:2> | IPC22<1:0> | Yes |
| ADC Data 30 ⁽²⁾ | _ADC_DATA30_VECTOR | 89 | OFF089<17:1> | IFS2<25> | IEC2<25> | IPC22<12:10> | IPC22<9:8> | Yes |
| ADC Data 31 ⁽²⁾ | _ADC_DATA31_VECTOR | 90 | OFF090<17:1> | IFS2<26> | IEC2<26> | IPC22<20:18> | IPC22<17:16> | Yes |
| ADC Data 32 ⁽²⁾ | _ADC_DATA32_VECTOR | 91 | OFF091<17:1> | IFS2<27> | IEC2<27> | IPC22<28:26> | IPC22<25:24> | Yes |
| ADC Data 33 ⁽²⁾ | _ADC_DATA33_VECTOR | 92 | OFF092<17:1> | IFS2<28> | IEC2<28> | IPC23<4:2> | IPC23<1:0> | Yes |
| ADC Data 34 ⁽²⁾ | _ADC_DATA34_VECTOR | 93 | OFF093<17:1> | IFS2<29> | IEC2<29> | IPC23<12:10> | IPC23<9:8> | Yes |
| ADC Data 35 ^(2,3) | _ADC_DATA35_VECTOR | 94 | OFF094<17:1> | IFS2<30> | IEC2<30> | IPC23<20:18> | IPC23<17:16> | Yes |
| ADC Data 36 ^(2,3) | _ADC_DATA36_VECTOR | 95 | OFF095<17:1> | IFS2<31> | IEC2<31> | IPC23<28:26> | IPC23<25:24> | Yes |
| ADC Data 37 ^(2,3) | _ADC_DATA37_VECTOR | 96 | OFF096<17:1> | IFS3<0> | IEC3<0> | IPC24<4:2> | IPC24<1:0> | Yes |
| ADC Data 38 ^(2,3) | _ADC_DATA38_VECTOR | 97 | OFF097<17:1> | IFS3<1> | IEC3<1> | IPC24<12:10> | IPC24<9:8> | Yes |
| ADC Data 39 ^(2,3) | _ADC_DATA39_VECTOR | 98 | OFF098<17:1> | IFS3<2> | IEC3<2> | IPC24<20:18> | IPC24<17:16> | Yes |
| ADC Data 40 ^(2,3) | _ADC_DATA40_VECTOR | 99 | OFF099<17:1> | IFS3<3> | IEC3<3> | IPC24<28:26> | IPC24<25:24> | Yes |
| ADC Data 41 ^(2,3) | _ADC_DATA41_VECTOR | 100 | OFF100<17:1> | IFS3<4> | IEC3<4> | IPC25<4:2> | IPC25<1:0> | Yes |
| ADC Data 42 ^(2,3) | _ADC_DATA42_VECTOR | 101 | OFF101<17:1> | IFS3<5> | IEC3<5> | IPC25<12:10> | IPC25<9:8> | Yes |
| ADC Data 43 | _ADC_DATA43_VECTOR | 102 | OFF102<17:1> | IFS3<6> | IEC3<6> | IPC25<20:18> | IPC25<17:16> | Yes |
| ADC Data 44 | _ADC_DATA44_VECTOR | 103 | OFF103<17:1> | IFS3<7> | IEC3<7> | IPC25<28:26> | IPC25<25:24> | Yes |
| Core Performance Counter Interrupt | _CORE_PERF_COUNT_VECTOR | 104 | OFF104<17:1> | IFS3<8> | IEC3<8> | IPC26<4:2> | IPC26<1:0> | No |
| Core Fast Debug Channel Interrupt | _CORE_FAST_DEBUG_CHAN_VECTOR | 105 | OFF105<17:1> | IFS3<9> | IEC3<9> | IPC26<12:10> | IPC26<9:8> | Yes |

Note 1: Not all interrupt sources are available on all devices. See [TABLE 1: "PIC32MZ EF Family Features"](#) for the list of available peripherals.

- 2:** This interrupt source is not available on 64-pin devices.
3: This interrupt source is not available on 100-pin devices.
4: This interrupt source is not available on 124-pin devices.

TABLE 7-2: INTERRUPT IRQ, VECTOR, AND BIT LOCATION (CONTINUED)

| Interrupt Source ⁽¹⁾ | XC32 Vector Name | IRQ # | Vector # | Interrupt Bit Location | | | | Persistent Interrupt |
|---|-------------------------------|-------|--------------|------------------------|----------|--------------|--------------|----------------------|
| | | | | Flag | Enable | Priority | Sub-priority | |
| System Bus Protection Violation | _SYSTEM_BUS_PROTECTION_VECTOR | 106 | OFF106<17:1> | IFS3<10> | IEC3<10> | IPC26<20:18> | IPC26<17:16> | Yes |
| Crypto Engine Event | _CRYPTO_VECTOR | 107 | OFF107<17:1> | IFS3<11> | IEC3<11> | IPC26<28:26> | IPC26<25:24> | Yes |
| Reserved | — | 108 | — | — | — | — | — | — |
| SPI1 Fault | _SPI1_FAULT_VECTOR | 109 | OFF109<17:1> | IFS3<13> | IEC3<13> | IPC27<12:10> | IPC27<9:8> | Yes |
| SPI1 Receive Done | _SPI1_RX_VECTOR | 110 | OFF110<17:1> | IFS3<14> | IEC3<14> | IPC27<20:18> | IPC27<17:16> | Yes |
| SPI1 Transfer Done | _SPI1_TX_VECTOR | 111 | OFF111<17:1> | IFS3<15> | IEC3<15> | IPC27<28:26> | IPC27<25:24> | Yes |
| UART1 Fault | _UART1_FAULT_VECTOR | 112 | OFF112<17:1> | IFS3<16> | IEC3<16> | IPC28<4:2> | IPC28<1:0> | Yes |
| UART1 Receive Done | _UART1_RX_VECTOR | 113 | OFF113<17:1> | IFS3<17> | IEC3<17> | IPC28<12:10> | IPC28<9:8> | Yes |
| UART1 Transfer Done | _UART1_TX_VECTOR | 114 | OFF114<17:1> | IFS3<18> | IEC3<18> | IPC28<20:18> | IPC28<17:16> | Yes |
| I2C1 Bus Collision Event | _I2C1_BUS_VECTOR | 115 | OFF115<17:1> | IFS3<19> | IEC3<19> | IPC28<28:26> | IPC28<25:24> | Yes |
| I2C1 Slave Event | _I2C1_SLAVE_VECTOR | 116 | OFF116<17:1> | IFS3<20> | IEC3<20> | IPC29<4:2> | IPC29<1:0> | Yes |
| I2C1 Master Event | _I2C1_MASTER_VECTOR | 117 | OFF117<17:1> | IFS3<21> | IEC3<21> | IPC29<12:10> | IPC29<9:8> | Yes |
| PORTA Input Change Interrupt ⁽²⁾ | _CHANGE_NOTICE_A_VECTOR | 118 | OFF118<17:1> | IFS3<22> | IEC3<22> | IPC29<20:18> | IPC29<17:16> | Yes |
| PORTB Input Change Interrupt | _CHANGE_NOTICE_B_VECTOR | 119 | OFF119<17:1> | IFS3<23> | IEC3<23> | IPC29<28:26> | IPC29<25:24> | Yes |
| PORTC Input Change Interrupt | _CHANGE_NOTICE_C_VECTOR | 120 | OFF120<17:1> | IFS3<24> | IEC3<24> | IPC30<4:2> | IPC30<1:0> | Yes |
| PORTD Input Change Interrupt | _CHANGE_NOTICE_D_VECTOR | 121 | OFF121<17:1> | IFS3<25> | IEC3<25> | IPC30<12:10> | IPC30<9:8> | Yes |
| PORTE Input Change Interrupt | _CHANGE_NOTICE_E_VECTOR | 122 | OFF122<17:1> | IFS3<26> | IEC3<26> | IPC30<20:18> | IPC30<17:16> | Yes |
| PORTF Input Change Interrupt | _CHANGE_NOTICE_F_VECTOR | 123 | OFF123<17:1> | IFS3<27> | IEC3<27> | IPC30<28:26> | IPC30<25:24> | Yes |
| PORTG Input Change Interrupt | _CHANGE_NOTICE_G_VECTOR | 124 | OFF124<17:1> | IFS3<28> | IEC3<28> | IPC31<4:2> | IPC31<1:0> | Yes |
| PORTH Input Change Interrupt ^(2,3) | _CHANGE_NOTICE_H_VECTOR | 125 | OFF125<17:1> | IFS3<29> | IEC3<29> | IPC31<12:10> | IPC31<9:8> | Yes |
| PORTJ Input Change Interrupt ^(2,3) | _CHANGE_NOTICE_J_VECTOR | 126 | OFF126<17:1> | IFS3<30> | IEC3<30> | IPC31<20:18> | IPC31<17:16> | Yes |
| PORTK Input Change Interrupt ^(2,3,4) | _CHANGE_NOTICE_K_VECTOR | 127 | OFF127<17:1> | IFS3<31> | IEC3<31> | IPC31<28:26> | IPC31<25:24> | Yes |
| Parallel Master Port | _PMP_VECTOR | 128 | OFF128<17:1> | IFS4<0> | IEC4<0> | IPC32<4:2> | IPC32<1:0> | Yes |
| Parallel Master Port Error | _PMP_ERROR_VECTOR | 129 | OFF129<17:1> | IFS4<1> | IEC4<1> | IPC32<12:10> | IPC32<9:8> | Yes |
| Comparator 1 Interrupt | _COMPARATOR_1_VECTOR | 130 | OFF130<17:1> | IFS4<2> | IEC4<2> | IPC32<20:18> | IPC32<17:16> | No |
| Comparator 2 Interrupt | _COMPARATOR_2_VECTOR | 131 | OFF131<17:1> | IFS4<3> | IEC4<3> | IPC32<28:26> | IPC32<25:24> | No |
| USB General Event | _USB1_VECTOR | 132 | OFF132<17:1> | IFS4<4> | IEC4<4> | IPC33<4:2> | IPC33<1:0> | No |
| USB DMA Event | _USB1_DMA_VECTOR | 133 | OFF133<17:1> | IFS4<5> | IEC4<5> | IPC33<12:10> | IPC33<9:8> | Yes |

Note 1: Not all interrupt sources are available on all devices. See [TABLE 1: "PIC32MZ EF Family Features"](#) for the list of available peripherals.

- 2:** This interrupt source is not available on 64-pin devices.
3: This interrupt source is not available on 100-pin devices.
4: This interrupt source is not available on 124-pin devices.

TABLE 7-2: INTERRUPT IRQ, VECTOR, AND BIT LOCATION (CONTINUED)

| Interrupt Source ⁽¹⁾ | XC32 Vector Name | IRQ # | Vector # | Interrupt Bit Location | | | | Persistent Interrupt |
|---|---------------------|-------|--------------|------------------------|----------|--------------|--------------|----------------------|
| | | | | Flag | Enable | Priority | Sub-priority | |
| DMA Channel 0 | _DMA0_VECTOR | 134 | OFF134<17:1> | IFS4<6> | IEC4<6> | IPC33<20:18> | IPC33<17:16> | No |
| DMA Channel 1 | _DMA1_VECTOR | 135 | OFF135<17:1> | IFS4<7> | IEC4<7> | IPC33<28:26> | IPC33<25:24> | No |
| DMA Channel 2 | _DMA2_VECTOR | 136 | OFF136<17:1> | IFS4<8> | IEC4<8> | IPC34<4:2> | IPC34<1:0> | No |
| DMA Channel 3 | _DMA3_VECTOR | 137 | OFF137<17:1> | IFS4<9> | IEC4<9> | IPC34<12:10> | IPC34<9:8> | No |
| DMA Channel 4 | _DMA4_VECTOR | 138 | OFF138<17:1> | IFS4<10> | IEC4<10> | IPC34<20:18> | IPC34<17:16> | No |
| DMA Channel 5 | _DMA5_VECTOR | 139 | OFF139<17:1> | IFS4<11> | IEC4<11> | IPC34<28:26> | IPC34<25:24> | No |
| DMA Channel 6 | _DMA6_VECTOR | 140 | OFF140<17:1> | IFS4<12> | IEC4<12> | IPC35<4:2> | IPC35<1:0> | No |
| DMA Channel 7 | _DMA7_VECTOR | 141 | OFF141<17:1> | IFS4<13> | IEC4<13> | IPC35<12:10> | IPC35<9:8> | No |
| SPI2 Fault | _SPI2_FAULT_VECTOR | 142 | OFF142<17:1> | IFS4<14> | IEC4<14> | IPC35<20:18> | IPC35<17:16> | Yes |
| SPI2 Receive Done | _SPI2_RX_VECTOR | 143 | OFF143<17:1> | IFS4<15> | IEC4<15> | IPC35<28:26> | IPC35<25:24> | Yes |
| SPI2 Transfer Done | _SPI2_TX_VECTOR | 144 | OFF144<17:1> | IFS4<16> | IEC4<16> | IPC36<4:2> | IPC36<1:0> | Yes |
| UART2 Fault | _UART2_FAULT_VECTOR | 145 | OFF145<17:1> | IFS4<17> | IEC4<17> | IPC36<12:10> | IPC36<9:8> | Yes |
| UART2 Receive Done | _UART2_RX_VECTOR | 146 | OFF146<17:1> | IFS4<18> | IEC4<18> | IPC36<20:18> | IPC36<17:16> | Yes |
| UART2 Transfer Done | _UART2_TX_VECTOR | 147 | OFF147<17:1> | IFS4<19> | IEC4<19> | IPC36<28:26> | IPC36<25:24> | Yes |
| I2C2 Bus Collision Event ⁽²⁾ | _I2C2_BUS_VECTOR | 148 | OFF148<17:1> | IFS4<20> | IEC4<20> | IPC37<4:2> | IPC37<1:0> | Yes |
| I2C2 Slave Event ⁽²⁾ | _I2C2_SLAVE_VECTOR | 149 | OFF149<17:1> | IFS4<21> | IEC4<21> | IPC37<12:10> | IPC37<9:8> | Yes |
| I2C2 Master Event ⁽²⁾ | _I2C2_MASTER_VECTOR | 150 | OFF150<17:1> | IFS4<22> | IEC4<22> | IPC37<20:18> | IPC37<17:16> | Yes |
| Control Area Network 1 | _CAN1_VECTOR | 151 | OFF151<17:1> | IFS4<23> | IEC4<23> | IPC37<28:26> | IPC37<25:24> | Yes |
| Control Area Network 2 | _CAN2_VECTOR | 152 | OFF152<17:1> | IFS4<24> | IEC4<24> | IPC38<4:2> | IPC38<1:0> | Yes |
| Ethernet Interrupt | _ETHERNET_VECTOR | 153 | OFF153<17:1> | IFS4<25> | IEC4<25> | IPC38<12:10> | IPC38<9:8> | Yes |
| SPI3 Fault | _SPI3_FAULT_VECTOR | 154 | OFF154<17:1> | IFS4<26> | IEC4<26> | IPC38<20:18> | IPC38<17:16> | Yes |
| SPI3 Receive Done | _SPI3_RX_VECTOR | 155 | OFF155<17:1> | IFS4<27> | IEC4<27> | IPC38<28:26> | IPC38<25:24> | Yes |
| SPI3 Transfer Done | _SPI3_TX_VECTOR | 156 | OFF156<17:1> | IFS4<28> | IEC4<28> | IPC39<4:2> | IPC39<1:0> | Yes |
| UART3 Fault | _UART3_FAULT_VECTOR | 157 | OFF157<17:1> | IFS4<29> | IEC4<29> | IPC39<12:10> | IPC39<9:8> | Yes |
| UART3 Receive Done | _UART3_RX_VECTOR | 158 | OFF158<17:1> | IFS4<30> | IEC4<30> | IPC39<20:18> | IPC39<17:16> | Yes |
| UART3 Transfer Done | _UART3_TX_VECTOR | 159 | OFF159<17:1> | IFS4<31> | IEC4<31> | IPC39<28:26> | IPC39<25:24> | Yes |
| I2C3 Bus Collision Event | _I2C3_BUS_VECTOR | 160 | OFF160<17:1> | IFS5<0> | IEC5<0> | IPC40<4:2> | IPC40<1:0> | Yes |
| I2C3 Slave Event | _I2C3_SLAVE_VECTOR | 161 | OFF161<17:1> | IFS5<1> | IEC5<1> | IPC40<12:10> | IPC40<9:8> | Yes |

Note 1: Not all interrupt sources are available on all devices. See [TABLE 1: "PIC32MZ EF Family Features"](#) for the list of available peripherals.

- Note 2:** This interrupt source is not available on 64-pin devices.
Note 3: This interrupt source is not available on 100-pin devices.
Note 4: This interrupt source is not available on 124-pin devices.

TABLE 7-2: INTERRUPT IRQ, VECTOR, AND BIT LOCATION (CONTINUED)

| Interrupt Source ⁽¹⁾ | XC32 Vector Name | IRQ # | Vector # | Interrupt Bit Location | | | | Persistent Interrupt |
|-----------------------------------|-----------------------|-------|--------------|------------------------|----------|--------------|--------------|----------------------|
| | | | | Flag | Enable | Priority | Sub-priority | |
| I2C3 Master Event | _I2C3_MASTER_VECTOR | 162 | OFF162<17:1> | IFS5<2> | IEC5<2> | IPC40<20:18> | IPC40<17:16> | Yes |
| SPI4 Fault | _SPI4_FAULT_VECTOR | 163 | OFF163<17:1> | IFS5<3> | IEC5<3> | IPC40<28:26> | IPC40<25:24> | Yes |
| SPI4 Receive Done | _SPI4_RX_VECTOR | 164 | OFF164<17:1> | IFS5<4> | IEC5<4> | IPC41<4:2> | IPC41<1:0> | Yes |
| SPI4 Transfer Done | _SPI4_TX_VECTOR | 165 | OFF165<17:1> | IFS5<5> | IEC5<5> | IPC41<12:10> | IPC41<9:8> | Yes |
| Real Time Clock | _RTCC_VECTOR | 166 | OFF166<17:1> | IFS5<6> | IEC5<6> | IPC41<20:18> | IPC41<17:16> | No |
| Flash Control Event | _FLASH_CONTROL_VECTOR | 167 | OFF167<17:1> | IFS5<7> | IEC5<7> | IPC41<28:26> | IPC41<25:24> | No |
| Prefetch Module SEC Event | _PREFETCH_VECTOR | 168 | OFF168<17:1> | IFS5<8> | IEC5<8> | IPC42<4:2> | IPC42<1:0> | Yes |
| SQ11 Event | _SQ11_VECTOR | 169 | OFF169<17:1> | IFS5<9> | IEC5<9> | IPC42<12:10> | IPC42<9:8> | Yes |
| UART4 Fault | _UART4_FAULT_VECTOR | 170 | OFF170<17:1> | IFS5<10> | IEC5<10> | IPC42<20:18> | IPC42<17:16> | Yes |
| UART4 Receive Done | _UART4_RX_VECTOR | 171 | OFF171<17:1> | IFS5<11> | IEC5<11> | IPC42<28:26> | IPC42<25:24> | Yes |
| UART4 Transfer Done | _UART4_TX_VECTOR | 172 | OFF172<17:1> | IFS5<12> | IEC5<12> | IPC43<4:2> | IPC43<1:0> | Yes |
| I2C4 Bus Collision Event | _I2C4_BUS_VECTOR | 173 | OFF173<17:1> | IFS5<13> | IEC5<13> | IPC43<12:10> | IPC43<9:8> | Yes |
| I2C4 Slave Event | _I2C4_SLAVE_VECTOR | 174 | OFF174<17:1> | IFS5<14> | IEC5<14> | IPC43<20:18> | IPC43<17:16> | Yes |
| I2C4 Master Event | _I2C4_MASTER_VECTOR | 175 | OFF175<17:1> | IFS5<15> | IEC5<15> | IPC43<28:26> | IPC43<25:24> | Yes |
| SPI5 Fault ⁽²⁾ | _SPI5_FAULT_VECTOR | 176 | OFF176<17:1> | IFS5<16> | IEC5<16> | IPC44<4:2> | IPC44<1:0> | Yes |
| SPI5 Receive Done ⁽²⁾ | _SPI5_RX_VECTOR | 177 | OFF177<17:1> | IFS5<17> | IEC5<17> | IPC44<12:10> | IPC44<9:8> | Yes |
| SPI5 Transfer Done ⁽²⁾ | _SPI5_TX_VECTOR | 178 | OFF178<17:1> | IFS5<18> | IEC5<18> | IPC44<20:18> | IPC44<17:16> | Yes |
| UART5 Fault | _UART5_FAULT_VECTOR | 179 | OFF179<17:1> | IFS5<19> | IEC5<19> | IPC44<28:26> | IPC44<25:24> | Yes |
| UART5 Receive Done | _UART5_RX_VECTOR | 180 | OFF180<17:1> | IFS5<20> | IEC5<20> | IPC45<4:2> | IPC45<1:0> | Yes |
| UART5 Transfer Done | _UART5_TX_VECTOR | 181 | OFF181<17:1> | IFS5<21> | IEC5<21> | IPC45<12:10> | IPC45<9:8> | Yes |
| I2C5 Bus Collision Event | _I2C5_BUS_VECTOR | 182 | OFF182<17:1> | IFS5<22> | IEC5<22> | IPC45<20:18> | IPC45<17:16> | Yes |
| I2C5 Slave Event | _I2C5_SLAVE_VECTOR | 183 | OFF183<17:1> | IFS5<23> | IEC5<23> | IPC45<28:26> | IPC45<25:24> | Yes |
| I2C5 Master Event | _I2C5_MASTER_VECTOR | 184 | OFF184<17:1> | IFS5<24> | IEC5<24> | IPC46<4:2> | IPC46<1:0> | Yes |
| SPI6 Fault ⁽²⁾ | _SPI6_FAULT_VECTOR | 185 | OFF185<17:1> | IFS5<25> | IEC5<25> | IPC46<12:10> | IPC46<9:8> | Yes |
| SPI6 Receive Done ⁽²⁾ | _SPI6_RX_VECTOR | 186 | OFF186<17:1> | IFS5<26> | IEC5<26> | IPC46<20:18> | IPC46<17:16> | Yes |
| SPI6 Transfer Done ⁽²⁾ | _SPI6_TX_VECTOR | 187 | OFF187<17:1> | IFS5<27> | IEC5<27> | IPC46<28:26> | IPC46<25:24> | Yes |
| UART6 Fault | _UART6_FAULT_VECTOR | 188 | OFF188<17:1> | IFS5<28> | IEC5<28> | IPC47<4:2> | IPC47<1:0> | Yes |
| UART6 Receive Done | _UART6_RX_VECTOR | 189 | OFF189<17:1> | IFS5<29> | IEC5<29> | IPC47<12:10> | IPC47<9:8> | Yes |

Note 1: Not all interrupt sources are available on all devices. See [TABLE 1: "PIC32MZ EF Family Features"](#) for the list of available peripherals.

- 2:** This interrupt source is not available on 64-pin devices.
3: This interrupt source is not available on 100-pin devices.
4: This interrupt source is not available on 124-pin devices.

TABLE 7-2: INTERRUPT IRQ, VECTOR, AND BIT LOCATION (CONTINUED)

| Interrupt Source ⁽¹⁾ | XC32 Vector Name | IRQ # | Vector # | Interrupt Bit Location | | | | Persistent Interrupt |
|-----------------------------------|--------------------|-------|--------------|------------------------|----------|--------------|--------------|----------------------|
| | | | | Flag | Enable | Priority | Sub-priority | |
| UART6 Transfer Done | _UART6_TX_VECTOR | 190 | OFF190<17:1> | IFS5<30> | IEC5<30> | IPC47<20:18> | IPC47<17:16> | Yes |
| Reserved | — | 191 | — | — | — | — | — | — |
| ADC End of Scan Ready | _ADC_EOS_VECTOR | 192 | OFF192<17:1> | IFS6<0> | IEC6<0> | IPC48<4:2> | IPC48<1:0> | Yes |
| ADC Analog Circuits Ready | _ADC_ARDY_VECTOR | 193 | OFF193<17:1> | IFS6<1> | IEC6<1> | IPC48<12:10> | IPC48<9:8> | Yes |
| ADC Update Ready | _ADC_URDY_VECTOR | 194 | OFF194<17:1> | IFS6<2> | IEC6<2> | IPC48<20:18> | IPC48<17:16> | Yes |
| Reserved | — | 195 | — | — | — | — | — | — |
| ADC Group Early Interrupt Request | _ADC_EARLY_VECTOR | 196 | OFF196<17:1> | IFS6<4> | IEC6<4> | IPC49<4:2> | IPC49<1:0> | Yes |
| Reserved | — | 197 | — | — | — | — | — | — |
| ADC0 Early Interrupt | _ADC0_EARLY_VECTOR | 198 | OFF198<17:1> | IFS6<6> | IEC6<6> | IPC49<20:18> | IPC49<17:16> | Yes |
| ADC1 Early Interrupt | _ADC1_EARLY_VECTOR | 199 | OFF199<17:1> | IFS6<7> | IEC6<7> | IPC49<28:26> | IPC49<25:24> | Yes |
| ADC2 Early Interrupt | _ADC2_EARLY_VECTOR | 200 | OFF200<17:1> | IFS6<8> | IEC6<8> | IPC50<4:2> | IPC50<1:0> | Yes |
| ADC3 Early Interrupt | _ADC3_EARLY_VECTOR | 201 | OFF201<17:1> | IFS6<9> | IEC6<9> | IPC50<12:10> | IPC50<9:8> | Yes |
| ADC4 Early Interrupt | _ADC4_EARLY_VECTOR | 202 | OFF202<17:1> | IFS6<10> | IEC6<10> | IPC50<20:18> | IPC50<17:16> | Yes |
| Reserved | — | 203 | — | — | — | — | — | — |
| Reserved | — | 204 | — | — | — | — | — | — |
| ADC7 Early Interrupt | _ADC7_EARLY_VECTOR | 205 | OFF205<17:1> | IFS6<13> | IEC6<13> | IPC51<12:10> | IPC51<9:8> | Yes |
| ADC0 Warm Interrupt | _ADC0_WARM_VECTOR | 206 | OFF206<17:1> | IFS6<14> | IEC6<14> | IPC51<20:18> | IPC51<17:16> | Yes |
| ADC1 Warm Interrupt | _ADC1_WARM_VECTOR | 207 | OFF207<17:1> | IFS6<15> | IEC6<15> | IPC51<28:26> | IPC51<25:24> | Yes |
| ADC2 Warm Interrupt | _ADC2_WARM_VECTOR | 208 | OFF208<17:1> | IFS6<16> | IEC6<16> | IPC52<4:2> | IPC52<1:0> | Yes |
| ADC3 Warm Interrupt | _ADC3_WARM_VECTOR | 209 | OFF209<17:1> | IFS6<17> | IEC6<17> | IPC52<12:10> | IPC52<9:8> | Yes |
| ADC4 Warm Interrupt | _ADC4_WARM_VECTOR | 210 | OFF210<17:1> | IFS6<18> | IEC6<18> | IPC52<20:18> | IPC52<17:16> | Yes |
| Reserved | — | 211 | — | — | — | — | — | — |
| Reserved | — | 212 | — | — | — | — | — | — |
| ADC7 Warm Interrupt | _ADC7_WARM_VECTOR | 213 | OFF213<17:1> | IFS6<21> | IEC6<21> | IPC53<12:10> | IPC53<9:8> | Yes |
| Lowest Natural Order Priority | | | | | | | | |

- Note 1:** Not all interrupt sources are available on all devices. See [TABLE 1: "PIC32MZ EF Family Features"](#) for the list of available peripherals.
- 2:** This interrupt source is not available on 64-pin devices.
- 3:** This interrupt source is not available on 100-pin devices.
- 4:** This interrupt source is not available on 124-pin devices.

7.3 Interrupt Control Registers

TABLE 7-3: INTERRUPT REGISTER MAP

| Virtual Address (BF81_#) | Register Name ⁽¹⁾ | Bit Range | Bits | | | | | | | | | | | | | | | All Resets | | | | | |
|-----------------------------|---------------------------------|-----------|----------------------|----------|-----------|----------|-----------------------|-------------------------|-----------------------|-----------------------|-----------------------|------------------------|------------------------|------------------------|----------|-------------------------|-------------------------|------------------------|--------|--------|------|-----|------|
| | | | 31/15 | 30/14 | 29/13 | 28/12 | 27/11 | 26/10 | 25/9 | 24/8 | 23/7 | 22/6 | 21/5 | 20/4 | 19/3 | 18/2 | 17/1 | | 16/0 | | | | |
| 0000 | INTCON | 31:16 | NMIKEY<7:0> | | | | | | | | | | | — | — | — | — | — | — | — | 0000 | | |
| | | 15:0 | — | — | — | MVEC | — | TPC<2:0> | | | | | — | — | — | INT4EP | INT3EP | INT2EP | INT1EP | INT0EP | 0000 | | |
| 0010 | PRISS | 31:16 | PRI7SS<3:0> | | | | | PRI6SS<3:0> | | | | | PRI5SS<3:0> | | | | | PRI4SS<3:0> | | | | | 0000 |
| | | 15:0 | PRI3SS<3:0> | | | | | PRI2SS<3:0> | | | | | PRI1SS<3:0> | | | | | — | — | — | — | SS0 | 0000 |
| 0020 | INTSTAT | 31:16 | — | — | — | — | — | — | — | — | — | — | — | — | — | — | — | — | — | — | 0000 | | |
| | | 15:0 | — | — | — | — | — | SRIPL<2:0> | | | | | SIRQ<7:0> | | | | | 0000 | | | | | |
| 0030 | IPTMR | 31:16 | IPTMR<31:0> | | | | | | | | | | | | | | | | | 0000 | | | |
| | | 15:0 | | | | | | | | | | | | | | | | | | 0000 | | | |
| 0040 | IFS0 | 31:16 | OC6IF | IC6IF | IC6EIF | T6IF | OC5IF | IC5IF | IC5EIF | T5IF | INT4IF | OC4IF | IC4IF | IC4EIF | T4IF | INT3IF | OC3IF | IC3IF | 0000 | | | | |
| | | 15:0 | IC3EIF | T3IF | INT2IF | OC2IF | IC2IF | IC2EIF | T2IF | INT1IF | OC1IF | IC1IF | IC1EIF | T1IF | INT0IF | CS1IF | CS0IF | CTIF | 0000 | | | | |
| 0050 | IFS1 | 31:16 | ADCD4IF | ADCD3IF | ADCD2IF | ADCD1IF | ADCD0IF | ADCFLTIF | ADCF6IF | ADCF5IF | ADCF4IF | ADCF3IF | ADCF2IF | ADCF1IF | ADCC6IF | ADCC5IF | ADCC4IF | ADCC3IF | 0000 | | | | |
| | | 15:0 | ADCC2IF | ADCC1IF | ADCFIFOIF | ADCIF | OC9IF | IC9IF | IC9EIF | T9IF | OC8IF | IC8IF | IC8EIF | T8IF | OC7IF | IC7IF | IC7EIF | T7IF | 0000 | | | | |
| 0060 | IFS2 ⁽⁵⁾ | 31:16 | ADCD36IF | ADCD35IF | ADCD34IF | ADCD33IF | ADCD32IF | ADCD31IF | ADCD30IF | ADCD29IF | ADCD28IF | ADCD27IF | ADCD26IF | ADCD25IF | ADCD24IF | ADCD23IF | ADCD22IF | ADCD21IF | 0000 | | | | |
| | | 15:0 | ADCD20IF | ADCD19IF | ADCD18IF | ADCD17IF | ADCD16IF | ADCD15IF | ADCD14IF | ADCD13IF | ADCD12IF | ADCD11IF | ADCD10IF | ADCD9IF | ADCD8IF | ADCD7IF | ADCD6IF | ADCD5IF | 0000 | | | | |
| 0070 | IFS3 ⁽⁶⁾ | 31:16 | CNKIF ⁽⁸⁾ | CNJIF | CNHIF | CNGIF | CNFIF | CNEIF | CNDIF | CNCIF | CNBIF | CNAIF | I2C1MIF | I2C1SIF | I2C1BIF | U1TXIF | U1RXIF | U1EIF | 0000 | | | | |
| | | 15:0 | SPI1TXIF | SPI1RXIF | SPI1EIF | — | CRPTIF ⁽⁷⁾ | SBIF | CFDCIF | CPCIF | ADCD44IF | ADCD43IF | ADCD42IF | ADCD41IF | ADCD40IF | ADCD39IF | ADCD38IF | ADCD37IF | 0000 | | | | |
| 0080 | IFS4 | 31:16 | U3TXIF | U3RXIF | U3EIF | SPI3TXIF | SPI3RXIF | SPI3EIF | ETHIF | CAN2IF ⁽³⁾ | CAN1IF ⁽³⁾ | I2C2MIF ⁽²⁾ | I2C2SIF ⁽²⁾ | I2C2BIF ⁽²⁾ | U2TXIF | U2RXIF | U2EIF | SPI2TXIF | 0000 | | | | |
| | | 15:0 | SPI2RXIF | SPI2EIF | DMA7IF | DMA6IF | DMA5IF | DMA4IF | DMA3IF | DMA2IF | DMA1IF | DMA0IF | USBDMAIF | USBIF | CMP2IF | CMP1IF | PMPEIF | PMPIF | 0000 | | | | |
| 0090 | IFS5 | 31:16 | — | U6TXIF | U6RXIF | U6EIF | SPI6TX ⁽²⁾ | SPI6RXIF ⁽²⁾ | SPI6IF ⁽²⁾ | I2C5MIF | I2C5SIF | I2C5BIF | U5TXIF | U5RXIF | U5EIF | SPI5TXIF ⁽²⁾ | SPI5RXIF ⁽²⁾ | SPI5EIF ⁽²⁾ | 0000 | | | | |
| | | 15:0 | I2C4MIF | I2C4SIF | I2C4BIF | U4TXIF | U4RXIF | U4EIF | SQI1IF | PREIF | FCEIF | RTCCIF | SPI4TXIF | SPI4RXIF | SPI4EIF | I2C3MIF | I2C3SIF | I2C3BIF | 0000 | | | | |
| 00A0 | IFS6 | 31:16 | — | — | — | — | — | — | — | — | — | ADC7WIF | — | — | ADC4WIF | ADC3WIF | ADC2WIF | 0000 | | | | | |
| | | 15:0 | ADC1WIF | ADC0WIF | ADC7EIF | — | — | ADC4EIF | ADC3EIF | ADC2EIF | ADC1EIF | ADC0EIF | — | ADCGRPIF | — | ADCURDYIF | ADCARDYIF | ADCEOSIF | 0000 | | | | |
| 00C0 | IEC0 | 31:16 | OC6IE | IC6IE | IC6EIE | T6IE | OC5IE | IC5IE | IC5EIE | T5IE | INT4IE | OC4IE | IC4IE | IC4EIE | T4IE | INT3IE | OC3IE | IC3IE | 0000 | | | | |
| | | 15:0 | IC3EIE | T3IE | INT2IE | OC2IE | IC2IE | IC2EIE | T2IE | INT1IE | OC1IE | IC1IE | IC1EIE | T1IE | INT0IE | CS1IE | CS0IE | CTIE | 0000 | | | | |
| 00D0 | IEC1 | 31:16 | ADCD4IE | ADCD3IE | ADCD2IE | ADCD1IE | ADCD0IE | ADCFLTIE | ADCF6IE | ADCF5IE | ADCF4IE | ADCF3IE | ADCF2IE | ADCF1IE | ADCC6IE | ADCC5IE | ADCC4IE | ADCC3IE | 0000 | | | | |
| | | 15:0 | ADCC2IE | ADCC1IE | ADCFIFOIE | ADCIE | OC9IE | IC9IE | IC9EIE | T9IE | OC8IE | IC8IE | IC8EIE | T8IE | OC7IE | IC7IE | IC7EIE | T7IE | 0000 | | | | |
| 00E0 | IEC2 ⁽⁵⁾ | 31:16 | ADCD36IE | ADCD35IE | ADCD34IE | ADCD33IE | ADCD32IE | ADCD31IE | ADCD30IE | ADCD29IE | ADCD28IE | ADCD27IE | ADCD26IE | ADCD25IE | ADCD24IE | ADCD23IE | ADCD22IE | ADCD21IE | 0000 | | | | |
| | | 15:0 | ADCD20IE | ADCD19IE | ADCD18IE | ADCD17IE | ADCD16IE | ADCD15IE | ADCD14IE | ADCD13IE | ADCD12IE | ADCD11IE | ADCD10IE | ADCD9IE | ADCD8IE | ADCD7IE | ADCD6IE | ADCD5IE | 0000 | | | | |

Legend: x = unknown value on Reset; — = unimplemented, read as '0'. Reset values are shown in hexadecimal.

- Note**
- 1: All registers in this table with the exception of the OFFx registers, have corresponding CLR, SET, and INV registers at their virtual addresses, plus offsets of 0x4, 0x8 and 0xC, respectively. See [Section 12.3 "CLR, SET, and INV Registers"](#) for more information.
 - 2: This bit or register is not available on 64-pin devices.
 - 3: This bit or register is not available on devices without a CAN module.
 - 4: This bit or register is not available on 100-pin devices.
 - 5: Bits 31 and 30 are not available on 64-pin and 100-pin devices; bits 29 through 14 are not available on 64-pin devices.
 - 6: Bits 31, 30, 29, and bits 5 through 0 are not available on 64-pin and 100-pin devices; bit 31 is not available on 124-pin devices; bit 22 is not available on 64-pin devices.
 - 7: This bit or register is not available on devices without a Crypto module.
 - 8: This bit or register is not available on 124-pin devices.

TABLE 7-3: INTERRUPT REGISTER MAP (CONTINUED)

| Virtual Address (BF81_#) | Register Name ⁽¹⁾ | Bit Range | Bits | | | | | | | | | | | | | | | | All Resets |
|-----------------------------|---------------------------------|-----------|----------|----------|---------|----------|-------------------------|-------------------------|------------------------|-----------------------|-----------------------|------------------------|------------------------|------------------------|-------------|-------------------------|-------------------------|------------------------|------------|
| | | | 31/15 | 30/14 | 29/13 | 28/12 | 27/11 | 26/10 | 25/9 | 24/8 | 23/7 | 22/6 | 21/5 | 20/4 | 19/3 | 18/2 | 17/1 | 16/0 | |
| 00F0 | IEC3 ⁽⁶⁾ | 31:16 | CNKIE | CNJIE | CNHIE | CNGIE | CNFIE | CNEIE | CNDIE | CNCIE | CNBIE | CNAIE | I2C1MIE | I2C1SIE | I2C1BIE | U1TXIE | U1RXIE | U1EIE | 0000 |
| | | 15:0 | SPI1TXIE | SPI1RXIE | SPI1EIE | — | CRPTIE ⁽⁷⁾ | SBIE | CFDCIE | CPCIE | ADCD44IE | ADCD43IE | ADCD42IE | ADCD41IE | ADCD40IE | ADCD39IE | ADCD38IE | ADCD37IE | 0000 |
| 0100 | IEC4 | 31:16 | U3TXIE | U3RXIE | U3EIE | SPI3TXIE | SPI3RXIE | SPI3EIE | ETHIE | CAN2IE ⁽³⁾ | CAN1IE ⁽³⁾ | I2C2MIE ⁽²⁾ | I2C2SIE ⁽²⁾ | I2C2BIE ⁽²⁾ | U2TXIE | U2RXIE | U2EIE | SPI2TXIE | 0000 |
| | | 15:0 | SPI2RXIE | SPI2EIE | DMA7IE | DMA6IE | DMA5IE | DMA4IE | DMA3IE | DMA2IE | DMA1IE | DMA0IE | USBDMAIE | USBIE | CMP2IE | CMP1IE | PMPEIE | PMPIE | 0000 |
| 0110 | IEC5 | 31:16 | — | U6TXIE | U6RXIE | U6EIE | SPI6TXIE ⁽²⁾ | SPI6RXIE ⁽²⁾ | SPI6EIE ⁽²⁾ | I2C5MIE | I2C5SIE | I2C5BIE | U5TXIE | U5RXIE | U5EIE | SPI5TXIE ⁽²⁾ | SPI5RXIE ⁽²⁾ | SPI5EIE ⁽²⁾ | 0000 |
| | | 15:0 | I2C4MIE | I2C4SIE | I2C4BIE | U4TXIE | U4RXIE | U4EIE | SQ11IE | PREIE | FCEIE | RTCCIE | SPI4TXIE | SPI4RXIE | SPI4EIE | I2C3MIE | I2C3SIE | I2C3BIE | 0000 |
| 0120 | IEC6 | 31:16 | — | — | — | — | — | — | — | — | — | — | ADC7WIE | — | — | ADC4WIE | ADC3WIE | ADC2WIE | 0000 |
| | | 15:0 | ADC1WIE | ADC0WIE | ADC7EIE | — | — | ADC4EIE | ADC3EIF | ADC2EIE | ADC1EIE | ADC0EIE | — | ADCGRPIE | — | ADCCURDYIE | ADCCARDYIE | ADCEOSIE | 0000 |
| 0140 | IPC0 | 31:16 | — | — | — | — | INT0IP<2:0> | — | INT0IS<1:0> | — | — | — | — | — | CS1IP<2:0> | — | CS1IS<1:0> | 0000 | |
| | | 15:0 | — | — | — | — | CS0IP<2:0> | — | CS0IS<1:0> | — | — | — | — | — | CTIP<2:0> | — | CTIS<1:0> | 0000 | |
| 0150 | IPC1 | 31:16 | — | — | — | — | OC1IP<2:0> | — | OC1IS<1:0> | — | — | — | — | — | IC1IP<2:0> | — | IC1IS<1:0> | 0000 | |
| | | 15:0 | — | — | — | — | IC1EIP<2:0> | — | IC1EIS<1:0> | — | — | — | — | — | T1IP<2:0> | — | T1IS<1:0> | 0000 | |
| 0160 | IPC2 | 31:16 | — | — | — | — | IC2IP<2:0> | — | IC2IS<1:0> | — | — | — | — | — | IC2EIP<2:0> | — | IC2EIS<1:0> | 0000 | |
| | | 15:0 | — | — | — | — | T2IP<2:0> | — | T2IS<1:0> | — | — | — | — | — | INT1IP<2:0> | — | INT1IS<1:0> | 0000 | |
| 0170 | IPC3 | 31:16 | — | — | — | — | IC3EIP<2:0> | — | IC3EIS<1:0> | — | — | — | — | — | T3IP<2:0> | — | T3IS<1:0> | 0000 | |
| | | 15:0 | — | — | — | — | INT2IP<2:0> | — | INT2IS<1:0> | — | — | — | — | — | OC2IP<2:0> | — | OC2IS<1:0> | 0000 | |
| 0180 | IPC4 | 31:16 | — | — | — | — | T4IP<2:0> | — | T4IS<1:0> | — | — | — | — | — | INT3IP<2:0> | — | INT3IS<1:0> | 0000 | |
| | | 15:0 | — | — | — | — | OC3IP<2:0> | — | OC3IS<1:0> | — | — | — | — | — | IC3IP<2:0> | — | IC3IS<1:0> | 0000 | |
| 0190 | IPC5 | 31:16 | — | — | — | — | INT4IP<2:0> | — | INT4IS<1:0> | — | — | — | — | — | OC4IP<2:0> | — | OC4IS<1:0> | 0000 | |
| | | 15:0 | — | — | — | — | IC4IP<2:0> | — | IC4IS<1:0> | — | — | — | — | — | IC4EIP<2:0> | — | IC4EIS<1:0> | 0000 | |
| 01A0 | IPC6 | 31:16 | — | — | — | — | OC5IP<2:0> | — | OC5IS<1:0> | — | — | — | — | — | IC5IP<2:0> | — | IC5IS<1:0> | 0000 | |
| | | 15:0 | — | — | — | — | IC5EIP<2:0> | — | IC5EIS<1:0> | — | — | — | — | — | T5IP<2:0> | — | T5IS<1:0> | 0000 | |
| 01B0 | IPC7 | 31:16 | — | — | — | — | OC6IP<2:0> | — | OC6IS<1:0> | — | — | — | — | — | IC6IP<2:0> | — | IC6IS<1:0> | 0000 | |
| | | 15:0 | — | — | — | — | IC6EIP<2:0> | — | IC6EIS<1:0> | — | — | — | — | — | T6IP<2:0> | — | T6IS<1:0> | 0000 | |
| 01C0 | IPC8 | 31:16 | — | — | — | — | OC7IP<2:0> | — | OC7IS<1:0> | — | — | — | — | — | IC7IP<2:0> | — | IC7IS<1:0> | 0000 | |
| | | 15:0 | — | — | — | — | IC7EIP<2:0> | — | IC7EIS<1:0> | — | — | — | — | — | T7IP<2:0> | — | T7IS<1:0> | 0000 | |
| 01D0 | IPC9 | 31:16 | — | — | — | — | OC8IP<2:0> | — | OC8IS<1:0> | — | — | — | — | — | IC8IP<2:0> | — | IC8IS<1:0> | 0000 | |
| | | 15:0 | — | — | — | — | IC8EIP<2:0> | — | IC8EIS<1:0> | — | — | — | — | — | T8IP<2:0> | — | T8IS<1:0> | 0000 | |
| 01E0 | IPC10 | 31:16 | — | — | — | — | OC9IP<2:0> | — | OC9IS<1:0> | — | — | — | — | — | IC9IP<2:0> | — | IC9IS<1:0> | 0000 | |
| | | 15:0 | — | — | — | — | IC9EIP<2:0> | — | IC9EIS<1:0> | — | — | — | — | — | T9IP<2:0> | — | T9IS<1:0> | 0000 | |

Legend: x = unknown value on Reset; — = unimplemented, read as '0'. Reset values are shown in hexadecimal.

- Note**
- 1: All registers in this table with the exception of the OFFx registers, have corresponding CLR, SET, and INV registers at their virtual addresses, plus offsets of 0x4, 0x8 and 0xC, respectively. See [Section 12.3 "CLR, SET, and INV Registers"](#) for more information.
 - 2: This bit or register is not available on 64-pin devices.
 - 3: This bit or register is not available on devices without a CAN module.
 - 4: This bit or register is not available on 100-pin devices.
 - 5: Bits 31 and 30 are not available on 64-pin and 100-pin devices; bits 29 through 14 are not available on 64-pin devices.
 - 6: Bits 31, 30, 29, and bits 5 through 0 are not available on 64-pin and 100-pin devices; bit 31 is not available on 124-pin devices; bit 22 is not available on 64-pin devices.
 - 7: This bit or register is not available on devices without a Crypto module.
 - 8: This bit or register is not available on 124-pin devices.

TABLE 7-3: INTERRUPT REGISTER MAP (CONTINUED)

| Virtual Address (BF81_#) | Register Name ⁽¹⁾ | Bit Range | Bits | | | | | | | | | | | | | | | All Resets | | |
|-----------------------------|---------------------------------|--------------|-------|-------|-------|--------------------------------|-------|-------|--------------------------------|------|------|------|------|------|--------------------------------|------|------|--------------------------------|------|------|
| | | | 31/15 | 30/14 | 29/13 | 28/12 | 27/11 | 26/10 | 25/9 | 24/8 | 23/7 | 22/6 | 21/5 | 20/4 | 19/3 | 18/2 | 17/1 | | 16/0 | |
| 01F0 | IPC11 | 31:16 | — | — | — | ADDC2IP<2:0> | | | ADDC2IS<1:0> | | | — | — | — | ADDC1IP<2:0> | | | ADDC1IS<1:0> | | 0000 |
| | | 15:0 | — | — | — | ADCFIFOIP<2:0> | | | ADCFIFOIS<1:0> | | | — | — | — | ADCIP<2:0> | | | ADCIS<1:0> | | 0000 |
| 0200 | IPC12 | 31:16 | — | — | — | ADDC6IP<2:0> | | | ADDC6IS<1:0> | | | — | — | — | ADDC5IP<2:0> | | | ADDC5IS<1:0> | | 0000 |
| | | 15:0 | — | — | — | ADDC4IP<2:0> | | | ADDC4IS<1:0> | | | — | — | — | ADDC3IP<2:0> | | | ADDC3IS<1:0> | | 0000 |
| 0210 | IPC13 | 31:16 | — | — | — | ADDCF4IP<2:0> | | | ADDCF4IS<1:0> | | | — | — | — | ADDCF3IP<2:0> | | | ADDCF3IS<1:0> | | 0000 |
| | | 15:0 | — | — | — | ADDCF2IP<2:0> | | | ADDCF2IS<1:0> | | | — | — | — | ADDCF1IP<2:0> | | | ADDCF1IS<1:0> | | 0000 |
| 0220 | IPC14 | 31:16 | — | — | — | ADCD0IP<2:0> | | | ADCD0IS<1:0> | | | — | — | — | ADCDLTIIP<2:0> | | | ADCDLTIIS<1:0> | | 0000 |
| | | 15:0 | — | — | — | ADCF6IP<2:0> | | | ADCF6IS<1:0> | | | — | — | — | ADCF5IP<2:0> | | | ADCF5IS<1:0> | | 0000 |
| 0230 | IPC15 | 31:16 | — | — | — | ADCD4IP<2:0> | | | ADCD4IS<1:0> | | | — | — | — | ADCD3IP<2:0> | | | ADCD3IS<1:0> | | 0000 |
| | | 15:0 | — | — | — | ADCD2IP<2:0> | | | ADCD2IS<1:0> | | | — | — | — | ADCD1IP<2:0> | | | ADCD1IS<1:0> | | 0000 |
| 0240 | IPC16 | 31:16 | — | — | — | ADCD8IP<2:0> | | | ADCD8IS<1:0> | | | — | — | — | ADCD7IP<2:0> | | | ADCD7IS<1:0> | | 0000 |
| | | 15:0 | — | — | — | ADCD6IP<2:0> | | | ADCD6IS<1:0> | | | — | — | — | ADCD5IP<2:0> | | | ADCD5IS<1:0> | | 0000 |
| 0250 | IPC17 | 31:16 | — | — | — | ADCD12IP<2:0> | | | ADCD12IS<1:0> | | | — | — | — | ADCD11IP<2:0> | | | ADCD11IS<1:0> | | 0000 |
| | | 15:0 | — | — | — | ADCD10IP<2:0> | | | ADCD10IS<1:0> | | | — | — | — | ADCD9IP<2:0> | | | ADCD9IS<1:0> | | 0000 |
| 0260 | IPC18 | 31:16 | — | — | — | ADCD16IP<2:0> | | | ADCD16IS<1:0> | | | — | — | — | ADCD15IP<2:0> | | | ADCD15IS<1:0> | | 0000 |
| | | 15:0 | — | — | — | ADCD14IP<2:0> | | | ADCD14IS<1:0> | | | — | — | — | ADCD13IP<2:0> | | | ADCD13IS<1:0> | | 0000 |
| 0270 | IPC19 | 31:16 | — | — | — | ADCD20IP<2:0> ⁽²⁾ | | | ADCD20IS<1:0> ⁽²⁾ | | | — | — | — | ADCD19IP<2:0> ⁽²⁾ | | | ADCD19IS<1:0> ⁽²⁾ | | 0000 |
| | | 15:0 | — | — | — | ADCD18IP<2:0> | | | ADCD18IS<1:0> | | | — | — | — | ADCD17IP<2:0> | | | ADCD17IS<1:0> | | 0000 |
| 0280 | IPC20 | 31:16 | — | — | — | ADCD24IP<2:0> ⁽²⁾ | | | ADCD24IS<1:0> ⁽²⁾ | | | — | — | — | ADCD23IP<2:0> ⁽²⁾ | | | ADCD23IS<1:0> ⁽²⁾ | | 0000 |
| | | 15:0 | — | — | — | ADCD22IP<2:0> ⁽²⁾ | | | ADCD22IS<1:0> ⁽²⁾ | | | — | — | — | ADCD21IP<2:0> ⁽²⁾ | | | ADCD21IS<1:0> ⁽²⁾ | | 0000 |
| 0290 | IPC21 | 31:16 | — | — | — | ADCD28IP<2:0> ⁽²⁾ | | | ADCD28IS<1:0> ⁽²⁾ | | | — | — | — | ADCD27IP<2:0> ⁽²⁾ | | | ADCD27IS<1:0> ⁽²⁾ | | 0000 |
| | | 15:0 | — | — | — | ADCD26IP<2:0> ⁽²⁾ | | | ADCD26IS<1:0> ⁽²⁾ | | | — | — | — | ADCD25IP<2:0> ⁽²⁾ | | | ADCD25IS<1:0> ⁽²⁾ | | 0000 |
| 02A0 | IPC22 | 31:16 | — | — | — | ADCD32IP<2:0> ⁽²⁾ | | | ADCD32IS<1:0> ⁽²⁾ | | | — | — | — | ADCD31IP<2:0> ⁽²⁾ | | | ADCD31IS<1:0> ⁽²⁾ | | 0000 |
| | | 15:0 | — | — | — | ADCD30IP<2:0> ⁽²⁾ | | | ADCD30IS<1:0> ⁽²⁾ | | | — | — | — | ADCD29IP<2:0> ⁽²⁾ | | | ADCD29IS<1:0> ⁽²⁾ | | 0000 |
| 02B0 | IPC23 | 31:16 | — | — | — | ADCD36IP<2:0> ^(2,4) | | | ADCD36IS<1:0> ^(2,4) | | | — | — | — | ADCD35IP<2:0> ^(2,4) | | | ADCD35IS<1:0> ^(2,4) | | 0000 |
| | | 15:0 | — | — | — | ADCD34IP<2:0> ⁽²⁾ | | | ADCD34IS<1:0> ⁽²⁾ | | | — | — | — | ADCD33IP<2:0> ⁽²⁾ | | | ADCD33IS<1:0> ⁽²⁾ | | 0000 |
| 02C0 | IPC24 | 31:16 | — | — | — | ADCD40IP<2:0> ^(2,4) | | | ADCD40IS<1:0> ^(2,4) | | | — | — | — | ADCD39IP<2:0> ^(2,4) | | | ADCD39IS<1:0> ^(2,4) | | 0000 |
| | | 15:0 | — | — | — | ADCD38IP<2:0> ^(2,4) | | | ADCD38IS<1:0> ^(2,4) | | | — | — | — | ADCD37IP<2:0> ^(2,4) | | | ADCD37IS<1:0> ^(2,4) | | 0000 |
| 02D0 | IPC25 | 31:16 | — | — | — | ADCD44IP<2:0> | | | ADCD44IS<1:0> | | | — | — | — | ADCD43IP<2:0> | | | ADCD43IS<1:0> | | 0000 |
| | | 15:0 | — | — | — | ADCD42IP<2:0> ^(2,4) | | | ADCD42IS<1:0> ^(2,4) | | | — | — | — | ADCD41IP<2:0> ^(2,4) | | | ADCD41IS<1:0> ^(2,4) | | 0000 |

Legend: x = unknown value on Reset; — = unimplemented, read as '0'. Reset values are shown in hexadecimal.

- Note**
- 1: All registers in this table with the exception of the OFFx registers, have corresponding CLR, SET, and INV registers at their virtual addresses, plus offsets of 0x4, 0x8 and 0xC, respectively. See [Section 12.3 “CLR, SET, and INV Registers”](#) for more information.
 - 2: This bit or register is not available on 64-pin devices.
 - 3: This bit or register is not available on devices without a CAN module.
 - 4: This bit or register is not available on 100-pin devices.
 - 5: Bits 31 and 30 are not available on 64-pin and 100-pin devices; bits 29 through 14 are not available on 64-pin devices.
 - 6: Bits 31, 30, 29, and bits 5 through 0 are not available on 64-pin and 100-pin devices; bit 31 is not available on 124-pin devices; bit 22 is not available on 64-pin devices.
 - 7: This bit or register is not available on devices without a Crypto module.
 - 8: This bit or register is not available on 124-pin devices.

TABLE 7-3: INTERRUPT REGISTER MAP (CONTINUED)

| Virtual Address (BF81_#) | Register Name ⁽¹⁾ | Bit Range | Bits | | | | | | | | | | | | | | | All Resets | |
|-----------------------------|---------------------------------|-----------|-------|-------|-------|-------------------------------|-------|-------|-------------------------------|------|------|------|------|-----------------------------|------|------|-----------------------------|------------|------|
| | | | 31/15 | 30/14 | 29/13 | 28/12 | 27/11 | 26/10 | 25/9 | 24/8 | 23/7 | 22/6 | 21/5 | 20/4 | 19/3 | 18/2 | 17/1 | | 16/0 |
| 02E0 | IPC26 | 31:16 | — | — | — | CRPTIP<2:0> ⁽⁷⁾ | | | CRPTIS<1:0> ⁽⁷⁾ | | | — | — | SBIP<2:0> | | | SBIS<1:0> | | 0000 |
| | | 15:0 | — | — | — | CFDCIP<2:0> | | | CFDCIS<1:0> | | | — | — | CPCIP<2:0> | | | CPCIS<1:0> | | 0000 |
| 02F0 | IPC27 | 31:16 | — | — | — | SPI1TXIP<2:0> | | | SPI1TXIS<1:0> | | | — | — | SPI1RXIP<2:0> | | | SPI1RXIS<1:0> | | 0000 |
| | | 15:0 | — | — | — | SPI1EIP<2:0> | | | SPI1EIS<1:0> | | | — | — | — | — | — | — | — | — |
| 0300 | IPC28 | 31:16 | — | — | — | I2C1BIP<2:0> | | | I2C1BIS<1:0> | | | — | — | U1TXIP<2:0> | | | U1TXIS<1:0> | | 0000 |
| | | 15:0 | — | — | — | U1RXIP<2:0> | | | U1RXIS<1:0> | | | — | — | U1EIP<2:0> | | | U1EIS<1:0> | | 0000 |
| 0310 | IPC29 | 31:16 | — | — | — | CNBIP<2:0> | | | CNBIS<1:0> | | | — | — | CNAIP<2:0> ⁽²⁾ | | | CNAIS<1:0> ⁽²⁾ | | 0000 |
| | | 15:0 | — | — | — | I2C1MIP<2:0> | | | I2C1MIS<1:0> | | | — | — | I2C1SIP<2:0> | | | I2C1SIS<1:0> | | 0000 |
| 0320 | IPC30 | 31:16 | — | — | — | CNFIP<2:0> | | | CNFIS<1:0> | | | — | — | CNEIP<2:0> | | | CNEIS<1:0> | | 0000 |
| | | 15:0 | — | — | — | CNDIP<2:0> | | | CNDIS<1:0> | | | — | — | CNCIP<2:0> | | | CNCIS<1:0> | | 0000 |
| 0330 | IPC31 | 31:16 | — | — | — | CNKIP<2:0> ^(2,4,8) | | | CNKIS<1:0> ^(2,4,8) | | | — | — | CNJIP<2:0> ^(2,4) | | | CNJIS<1:0> ^(2,4) | | 0000 |
| | | 15:0 | — | — | — | CNHIP<2:0> ^(2,4) | | | CNHIS<1:0> ^(2,4) | | | — | — | CNGIP<2:0> | | | CNGIS<1:0> | | 0000 |
| 0340 | IPC32 | 31:16 | — | — | — | CMP2IP<2:0> | | | CMP2IS<1:0> | | | — | — | CMP1IP<2:0> | | | CMP1IS<1:0> | | 0000 |
| | | 15:0 | — | — | — | PMPEIP<2:0> | | | PMPEIS<1:0> | | | — | — | PMPIP<2:0> | | | PMPIS<1:0> | | 0000 |
| 0350 | IPC33 | 31:16 | — | — | — | DMA1IP<2:0> | | | DMA1IS<1:0> | | | — | — | DMA0IP<2:0> | | | DMA0IS<1:0> | | 0000 |
| | | 15:0 | — | — | — | USBDMAIP<2:0> | | | USBDMAIS<1:0> | | | — | — | USBIP<2:0> | | | USBIS<1:0> | | 0000 |
| 0360 | IPC34 | 31:16 | — | — | — | DMA5IP<2:0> | | | DMA5IS<1:0> | | | — | — | DMA4IP<2:0> | | | DMA4IS<1:0> | | 0000 |
| | | 15:0 | — | — | — | DMA3IP<2:0> | | | DMA3IS<1:0> | | | — | — | DMA2IP<2:0> | | | DMA2IS<1:0> | | 0000 |
| 0370 | IPC35 | 31:16 | — | — | — | SPI2RXIP<2:0> | | | SPI2RXIS<1:0> | | | — | — | SPI2EIP<2:0> | | | SPI2EIS<1:0> | | 0000 |
| | | 15:0 | — | — | — | DMA7IP<2:0> | | | DMA7IS<1:0> | | | — | — | DMA6IP<2:0> | | | DMA6IS<1:0> | | 0000 |
| 0380 | IPC36 | 31:16 | — | — | — | U2TXIP<2:0> | | | U2TXIS<1:0> | | | — | — | U2RXIP<2:0> | | | U2RXIS<1:0> | | 0000 |
| | | 15:0 | — | — | — | U2EIP<2:0> | | | U2EIS<1:0> | | | — | — | SPI2TXIP<2:0> | | | SPI2TXIS<1:0> | | 0000 |
| 0390 | IPC37 | 31:16 | — | — | — | CAN1IP<2:0> ⁽³⁾ | | | CAN1IS<1:0> ⁽³⁾ | | | — | — | I2C2MIP<2:0> ⁽²⁾ | | | I2C2MIS<1:0> ⁽²⁾ | | 0000 |
| | | 15:0 | — | — | — | I2C2SIP<2:0> ⁽²⁾ | | | I2C2SIS<1:0> ⁽²⁾ | | | — | — | I2C2BIP<2:0> ⁽²⁾ | | | I2C2BIS<1:0> ⁽²⁾ | | 0000 |
| 03A0 | IPC38 | 31:16 | — | — | — | SPI3RXIP<2:0> | | | SPI3RXIS<1:0> | | | — | — | SPI3EIP<2:0> | | | SPI3EIS<1:0> | | 0000 |
| | | 15:0 | — | — | — | ETHIP<2:0> | | | ETHIS<1:0> | | | — | — | CAN2IP<2:0> ⁽³⁾ | | | CAN2IS<1:0> ⁽³⁾ | | 0000 |
| 03B0 | IPC39 | 31:16 | — | — | — | U3TXIP<2:0> | | | U3TXIS<1:0> | | | — | — | U3RXIP<2:0> | | | U3RXIS<1:0> | | 0000 |
| | | 15:0 | — | — | — | U3EIP<2:0> | | | U3EIS<1:0> | | | — | — | SPI3TXIP<2:0> | | | SPI3TXIS<1:0> | | 0000 |
| 03C0 | IPC40 | 31:16 | — | — | — | SPI4EIP<2:0> | | | SPI4EIS<1:0> | | | — | — | I2C3MIP<2:0> | | | I2C3MIS<1:0> | | 0000 |
| | | 15:0 | — | — | — | I2C3SIP<2:0> | | | I2C3SIS<1:0> | | | — | — | I2C3BIP<2:0> | | | I2C3BIS<1:0> | | 0000 |

Legend: x = unknown value on Reset; — = unimplemented, read as '0'. Reset values are shown in hexadecimal.

- Note**
- 1: All registers in this table with the exception of the OFFx registers, have corresponding CLR, SET, and INV registers at their virtual addresses, plus offsets of 0x4, 0x8 and 0xC, respectively. See [Section 12.3 “CLR, SET, and INV Registers”](#) for more information.
 - 2: This bit or register is not available on 64-pin devices.
 - 3: This bit or register is not available on devices without a CAN module.
 - 4: This bit or register is not available on 100-pin devices.
 - 5: Bits 31 and 30 are not available on 64-pin and 100-pin devices; bits 29 through 14 are not available on 64-pin devices.
 - 6: Bits 31, 30, 29, and bits 5 through 0 are not available on 64-pin and 100-pin devices; bit 31 is not available on 124-pin devices; bit 22 is not available on 64-pin devices.
 - 7: This bit or register is not available on devices without a Crypto module.
 - 8: This bit or register is not available on 124-pin devices.

TABLE 7-3: INTERRUPT REGISTER MAP (CONTINUED)

| Virtual Address (BF81_#) | Register Name ⁽¹⁾ | Bit Range | Bits | | | | | | | | | | | | | | | All Resets | | | |
|-----------------------------|---------------------------------|--------------|------------|-------|-------|------------------------------|-------|-------|------------------------------|------|------|------|------|------|------------------------------|----------------|------|------------------------------|----------------|------|------|
| | | | 31/15 | 30/14 | 29/13 | 28/12 | 27/11 | 26/10 | 25/9 | 24/8 | 23/7 | 22/6 | 21/5 | 20/4 | 19/3 | 18/2 | 17/1 | | 16/0 | | |
| 03D0 | IPC41 | 31:16 | — | — | — | FCEIP<2:0> | | | FCEIS<1:0> | | | — | — | — | RTCCIP<2:0> | | | RTCCIS<1:0> | | 0000 | |
| | | 15:0 | — | — | — | SPI4TXIP<2:0> | | | SPI4TXIS<1:0> | | | — | — | — | SPI4RXIP<2:0> | | | SPI4RXIS<1:0> | | 0000 | |
| 03E0 | IPC42 | 31:16 | — | — | — | U4RXIP<2:0> | | | U4RXIS<1:0> | | | — | — | — | U4EIP<2:0> | | | U4EIS<1:0> | | 0000 | |
| | | 15:0 | — | — | — | SQI1IP<2:0> | | | SQI1IS<1:0> | | | — | — | — | PREIP<2:0> | | | PREIS<1:0> | | 0000 | |
| 03F0 | IPC43 | 31:16 | — | — | — | I2C4MIP<2:0> | | | I2C4MIS<1:0> | | | — | — | — | I2C4SIP<2:0> | | | I2C4SIS<1:0> | | 0000 | |
| | | 15:0 | — | — | — | I2C4BIP<2:0> | | | I2C4BIS<1:0> | | | — | — | — | U4TXIP<2:0> | | | U4TXIS<1:0> | | 0000 | |
| 0400 | IPC44 | 31:16 | — | — | — | U5EIP<2:0> | | | U5EIS<1:0> | | | — | — | — | SPI5TXIP<2:0> ⁽²⁾ | | | SPI5TXIS<1:0> ⁽²⁾ | | 0000 | |
| | | 15:0 | — | — | — | SPI5RXIP<2:0> ⁽²⁾ | | | SPI5RXIS<1:0> ⁽²⁾ | | | — | — | — | SPI5EIP<2:0> ⁽²⁾ | | | SPI5EIS<1:0> ⁽²⁾ | | 0000 | |
| 0410 | IPC45 | 31:16 | — | — | — | I2C5SIP<2:0> | | | I2C5SIS<1:0> | | | — | — | — | I2C5BIP<2:0> | | | I2C5BIS<1:0> | | 0000 | |
| | | 15:0 | — | — | — | U5TXIP<2:0> | | | U5TXIS<1:0> | | | — | — | — | U5RXIP<2:0> | | | U5RXIS<1:0> | | 0000 | |
| 0420 | IPC46 | 31:16 | — | — | — | SPI6TXIP<2:0> ⁽²⁾ | | | SPI6TXIS<1:0> ⁽²⁾ | | | — | — | — | SPI6RXIP<2:0> ⁽²⁾ | | | SPI6RXIS<1:0> ⁽²⁾ | | 0000 | |
| | | 15:0 | — | — | — | SPI6EIP<2:0> ⁽²⁾ | | | SPI6EIS<1:0> ⁽²⁾ | | | — | — | — | I2C5MIP<2:0> | | | I2C5MIS<1:0> | | 0000 | |
| 0430 | IPC47 | 31:16 | — | — | — | — | — | — | — | — | — | — | — | — | — | U6TXIP<2:0> | | | U6TXIS<1:0> | | 0000 |
| | | 15:0 | — | — | — | U6RXIP<2:0> | | | U6RXIS<1:0> | | | — | — | — | U6EIP<2:0> | | | U6EIS<1:0> | | 0000 | |
| 0440 | IPC48 | 31:16 | — | — | — | — | — | — | — | — | — | — | — | — | — | ADCURDYIP<2:0> | | | ADCURDYIS<1:0> | | 0000 |
| | | 15:0 | — | — | — | ADCARDYIP<2:0> | | | ADCARDYIS<1:0> | | | — | — | — | ADCEOSIP<2:0> | | | ADCEOSIS<1:0> | | 0000 | |
| 0450 | IPC49 | 31:16 | — | — | — | ADC1EIP<2:0> | | | ADC1EIS<1:0> | | | — | — | — | ADC0EIP<2:0> | | | ADC0EIS<1:0> | | 0000 | |
| | | 15:0 | — | — | — | — | — | — | — | — | — | — | — | — | — | ADCGRPIP<2:0> | | | ADCGRPIS<1:0> | | 0000 |
| 0460 | IPC50 | 31:16 | — | — | — | — | — | — | — | — | — | — | — | — | — | ADC4EIP<2:0> | | | ADC4EIS<1:0> | | 0000 |
| | | 15:0 | — | — | — | ADC3EIP<2:0> | | | ADC3EIS<1:0> | | | — | — | — | ADC2EIP<2:0> | | | ADC2EIS<1:0> | | 0000 | |
| 0470 | IPC51 | 31:16 | — | — | — | ADC1WIP<2:0> | | | ADC1WIS<1:0> | | | — | — | — | ADC0WIP<2:0> | | | ADC0WIS<1:0> | | 0000 | |
| | | 15:0 | — | — | — | ADC7EIP<2:0> | | | ADC7EIS<1:0> | | | — | — | — | — | — | — | — | — | — | 0000 |
| 0480 | IPC52 | 31:16 | — | — | — | — | — | — | — | — | — | — | — | — | — | ADC4WIP<2:0> | | | ADC4WIS<1:0> | | 0000 |
| | | 15:0 | — | — | — | ADC3WIP<2:0> | | | ADC3WIS<1:0> | | | — | — | — | ADC2WIP<2:0> | | | ADC2WIS<1:0> | | 0000 | |
| 0490 | IPC53 | 31:16 | — | — | — | — | — | — | — | — | — | — | — | — | — | — | — | — | — | — | 0000 |
| | | 15:0 | — | — | — | ADC7WIP<2:0> | | | ADC7WIS<1:0> | | | — | — | — | — | — | — | — | — | — | 0000 |
| 0540 | OFF000 | 31:16 | — | — | — | — | — | — | — | — | — | — | — | — | — | — | — | — | VOFF<17:16> | | 0000 |
| | | 15:0 | VOFF<15:1> | | | | | | | | | | | | | | | — | 0000 | | |
| 0544 | OFF001 | 31:16 | — | — | — | — | — | — | — | — | — | — | — | — | — | — | — | — | VOFF<17:16> | | 0000 |
| | | 15:0 | VOFF<15:1> | | | | | | | | | | | | | | | — | 0000 | | |

Legend: x = unknown value on Reset; — = unimplemented, read as '0'. Reset values are shown in hexadecimal.

- Note**
- 1: All registers in this table with the exception of the OFFx registers, have corresponding CLR, SET, and INV registers at their virtual addresses, plus offsets of 0x4, 0x8 and 0xC, respectively. See [Section 12.3 “CLR, SET, and INV Registers”](#) for more information.
 - 2: This bit or register is not available on 64-pin devices.
 - 3: This bit or register is not available on devices without a CAN module.
 - 4: This bit or register is not available on 100-pin devices.
 - 5: Bits 31 and 30 are not available on 64-pin and 100-pin devices; bits 29 through 14 are not available on 64-pin devices.
 - 6: Bits 31, 30, 29, and bits 5 through 0 are not available on 64-pin and 100-pin devices; bit 31 is not available on 124-pin devices; bit 22 is not available on 64-pin devices.
 - 7: This bit or register is not available on devices without a Crypto module.
 - 8: This bit or register is not available on 124-pin devices.

TABLE 7-3: INTERRUPT REGISTER MAP (CONTINUED)

| Virtual Address (BF81_#) | Register Name ⁽¹⁾ | Bit Range | Bits | | | | | | | | | | | | | | All Resets | |
|-----------------------------|---------------------------------|-----------|------------|-------|-------|-------|-------|-------|------|------|------|------|------|------|------|------|-------------|------|
| | | | 31/15 | 30/14 | 29/13 | 28/12 | 27/11 | 26/10 | 25/9 | 24/8 | 23/7 | 22/6 | 21/5 | 20/4 | 19/3 | 18/2 | | 17/1 |
| 0548 | OFF002 | 31:16 | — | — | — | — | — | — | — | — | — | — | — | — | — | — | VOFF<17:16> | 0000 |
| | | 15:0 | VOFF<15:1> | | | | | | | | | | | | | | — | 0000 |
| 054C | OFF003 | 31:16 | — | — | — | — | — | — | — | — | — | — | — | — | — | — | VOFF<17:16> | 0000 |
| | | 15:0 | VOFF<15:1> | | | | | | | | | | | | | | — | 0000 |
| 0550 | OFF004 | 31:16 | — | — | — | — | — | — | — | — | — | — | — | — | — | — | VOFF<17:16> | 0000 |
| | | 15:0 | VOFF<15:1> | | | | | | | | | | | | | | — | 0000 |
| 0554 | OFF005 | 31:16 | — | — | — | — | — | — | — | — | — | — | — | — | — | — | VOFF<17:16> | 0000 |
| | | 15:0 | VOFF<15:1> | | | | | | | | | | | | | | — | 0000 |
| 0558 | OFF006 | 31:16 | — | — | — | — | — | — | — | — | — | — | — | — | — | — | VOFF<17:16> | 0000 |
| | | 15:0 | VOFF<15:1> | | | | | | | | | | | | | | — | 0000 |
| 055C | OFF007 | 31:16 | — | — | — | — | — | — | — | — | — | — | — | — | — | — | VOFF<17:16> | 0000 |
| | | 15:0 | VOFF<15:1> | | | | | | | | | | | | | | — | 0000 |
| 0560 | OFF008 | 31:16 | — | — | — | — | — | — | — | — | — | — | — | — | — | — | VOFF<17:16> | 0000 |
| | | 15:0 | VOFF<15:1> | | | | | | | | | | | | | | — | 0000 |
| 0564 | OFF009 | 31:16 | — | — | — | — | — | — | — | — | — | — | — | — | — | — | VOFF<17:16> | 0000 |
| | | 15:0 | VOFF<15:1> | | | | | | | | | | | | | | — | 0000 |
| 0568 | OFF010 | 31:16 | — | — | — | — | — | — | — | — | — | — | — | — | — | — | VOFF<17:16> | 0000 |
| | | 15:0 | VOFF<15:1> | | | | | | | | | | | | | | — | 0000 |
| 056C | OFF011 | 31:16 | — | — | — | — | — | — | — | — | — | — | — | — | — | — | VOFF<17:16> | 0000 |
| | | 15:0 | VOFF<15:1> | | | | | | | | | | | | | | — | 0000 |
| 0570 | OFF012 | 31:16 | — | — | — | — | — | — | — | — | — | — | — | — | — | — | VOFF<17:16> | 0000 |
| | | 15:0 | VOFF<15:1> | | | | | | | | | | | | | | — | 0000 |
| 0574 | OFF013 | 31:16 | — | — | — | — | — | — | — | — | — | — | — | — | — | — | VOFF<17:16> | 0000 |
| | | 15:0 | VOFF<15:1> | | | | | | | | | | | | | | — | 0000 |
| 0578 | OFF014 | 31:16 | — | — | — | — | — | — | — | — | — | — | — | — | — | — | VOFF<17:16> | 0000 |
| | | 15:0 | VOFF<15:1> | | | | | | | | | | | | | | — | 0000 |
| 057C | OFF015 | 31:16 | — | — | — | — | — | — | — | — | — | — | — | — | — | — | VOFF<17:16> | 0000 |
| | | 15:0 | VOFF<15:1> | | | | | | | | | | | | | | — | 0000 |
| 0580 | OFF016 | 31:16 | — | — | — | — | — | — | — | — | — | — | — | — | — | — | VOFF<17:16> | 0000 |
| | | 15:0 | VOFF<15:1> | | | | | | | | | | | | | | — | 0000 |

Legend: x = unknown value on Reset; — = unimplemented, read as '0'. Reset values are shown in hexadecimal.

- Note**
- 1: All registers in this table with the exception of the OFFx registers, have corresponding CLR, SET, and INV registers at their virtual addresses, plus offsets of 0x4, 0x8 and 0xC, respectively. See [Section 12.3 "CLR, SET, and INV Registers"](#) for more information.
 - 2: This bit or register is not available on 64-pin devices.
 - 3: This bit or register is not available on devices without a CAN module.
 - 4: This bit or register is not available on 100-pin devices.
 - 5: Bits 31 and 30 are not available on 64-pin and 100-pin devices; bits 29 through 14 are not available on 64-pin devices.
 - 6: Bits 31, 30, 29, and bits 5 through 0 are not available on 64-pin and 100-pin devices; bit 31 is not available on 124-pin devices; bit 22 is not available on 64-pin devices.
 - 7: This bit or register is not available on devices without a Crypto module.
 - 8: This bit or register is not available on 124-pin devices.

TABLE 7-3: INTERRUPT REGISTER MAP (CONTINUED)

| Virtual Address (BF81_#) | Register Name ⁽¹⁾ | Bit Range | Bits | | | | | | | | | | | | | | | All Resets | |
|-----------------------------|---------------------------------|--------------|------------|-------|-------|-------|-------|-------|------|------|------|------|------|------|------|------|------|---------------|------|
| | | | 31/15 | 30/14 | 29/13 | 28/12 | 27/11 | 26/10 | 25/9 | 24/8 | 23/7 | 22/6 | 21/5 | 20/4 | 19/3 | 18/2 | 17/1 | | 16/0 |
| 0584 | OFF017 | 31:16 | — | — | — | — | — | — | — | — | — | — | — | — | — | — | — | VOFF<17:16> | 0000 |
| | | 15:0 | VOFF<15:1> | | | | | | | | | | | | | | | — | 0000 |
| 0588 | OFF018 | 31:16 | — | — | — | — | — | — | — | — | — | — | — | — | — | — | — | VOFF<17:16> | 0000 |
| | | 15:0 | VOFF<15:1> | | | | | | | | | | | | | | | — | 0000 |
| 058C | OFF019 | 31:16 | — | — | — | — | — | — | — | — | — | — | — | — | — | — | — | VOFF<17:16> | 0000 |
| | | 15:0 | VOFF<15:1> | | | | | | | | | | | | | | | — | 0000 |
| 0590 | OFF020 | 31:16 | — | — | — | — | — | — | — | — | — | — | — | — | — | — | — | VOFF<17:16> | 0000 |
| | | 15:0 | VOFF<15:1> | | | | | | | | | | | | | | | — | 0000 |
| 0594 | OFF021 | 31:16 | — | — | — | — | — | — | — | — | — | — | — | — | — | — | — | VOFF<17:16> | 0000 |
| | | 15:0 | VOFF<15:1> | | | | | | | | | | | | | | | — | 0000 |
| 0598 | OFF022 | 31:16 | — | — | — | — | — | — | — | — | — | — | — | — | — | — | — | VOFF<17:16> | 0000 |
| | | 15:0 | VOFF<15:1> | | | | | | | | | | | | | | | — | 0000 |
| 059C | OFF023 | 31:16 | — | — | — | — | — | — | — | — | — | — | — | — | — | — | — | VOFF<17:16> | 0000 |
| | | 15:0 | VOFF<15:1> | | | | | | | | | | | | | | | — | 0000 |
| 05A0 | OFF024 | 31:16 | — | — | — | — | — | — | — | — | — | — | — | — | — | — | — | VOFF<17:16> | 0000 |
| | | 15:0 | VOFF<15:1> | | | | | | | | | | | | | | | — | 0000 |
| 05A4 | OFF025 | 31:16 | — | — | — | — | — | — | — | — | — | — | — | — | — | — | — | VOFF<17:16> | 0000 |
| | | 15:0 | VOFF<15:1> | | | | | | | | | | | | | | | — | 0000 |
| 05A8 | OFF026 | 31:16 | — | — | — | — | — | — | — | — | — | — | — | — | — | — | — | VOFF<17:16> | 0000 |
| | | 15:0 | VOFF<15:1> | | | | | | | | | | | | | | | — | 0000 |
| 05AC | OFF027 | 31:16 | — | — | — | — | — | — | — | — | — | — | — | — | — | — | — | VOFF<17:16> | 0000 |
| | | 15:0 | VOFF<15:1> | | | | | | | | | | | | | | | — | 0000 |
| 05B0 | OFF028 | 31:16 | — | — | — | — | — | — | — | — | — | — | — | — | — | — | — | VOFF<17:16> | 0000 |
| | | 15:0 | VOFF<15:1> | | | | | | | | | | | | | | | — | 0000 |
| 05B4 | OFF029 | 31:16 | — | — | — | — | — | — | — | — | — | — | — | — | — | — | — | VOFF<17:16> | 0000 |
| | | 15:0 | VOFF<15:1> | | | | | | | | | | | | | | | — | 0000 |
| 05B8 | OFF030 | 31:16 | — | — | — | — | — | — | — | — | — | — | — | — | — | — | — | VOFF<17:16> | 0000 |
| | | 15:0 | VOFF<15:1> | | | | | | | | | | | | | | | — | 0000 |
| 05BC | OFF031 | 31:16 | — | — | — | — | — | — | — | — | — | — | — | — | — | — | — | VOFF<17:16> | 0000 |
| | | 15:0 | VOFF<15:1> | | | | | | | | | | | | | | | — | 0000 |

Legend: x = unknown value on Reset; — = unimplemented, read as '0'. Reset values are shown in hexadecimal.

- Note**
- 1: All registers in this table with the exception of the OFFx registers, have corresponding CLR, SET, and INV registers at their virtual addresses, plus offsets of 0x4, 0x8 and 0xC, respectively. See [Section 12.3 “CLR, SET, and INV Registers”](#) for more information.
 - 2: This bit or register is not available on 64-pin devices.
 - 3: This bit or register is not available on devices without a CAN module.
 - 4: This bit or register is not available on 100-pin devices.
 - 5: Bits 31 and 30 are not available on 64-pin and 100-pin devices; bits 29 through 14 are not available on 64-pin devices.
 - 6: Bits 31, 30, 29, and bits 5 through 0 are not available on 64-pin and 100-pin devices; bit 31 is not available on 124-pin devices; bit 22 is not available on 64-pin devices.
 - 7: This bit or register is not available on devices without a Crypto module.
 - 8: This bit or register is not available on 124-pin devices.

TABLE 7-3: INTERRUPT REGISTER MAP (CONTINUED)

| Virtual Address (BF81_#) | Register Name ⁽¹⁾ | Bit Range | Bits | | | | | | | | | | | | | | | All Resets | |
|-----------------------------|---------------------------------|-----------|------------|-------|-------|-------|-------|-------|------|------|------|------|------|------|------|------|------|-------------|------|
| | | | 31/15 | 30/14 | 29/13 | 28/12 | 27/11 | 26/10 | 25/9 | 24/8 | 23/7 | 22/6 | 21/5 | 20/4 | 19/3 | 18/2 | 17/1 | | 16/0 |
| 05C0 | OFF032 | 31:16 | — | — | — | — | — | — | — | — | — | — | — | — | — | — | — | VOFF<17:16> | 0000 |
| | | 15:0 | VOFF<15:1> | | | | | | | | | | | | | | | — | 0000 |
| 05C4 | OFF033 | 31:16 | — | — | — | — | — | — | — | — | — | — | — | — | — | — | — | VOFF<17:16> | 0000 |
| | | 15:0 | VOFF<15:1> | | | | | | | | | | | | | | | — | 0000 |
| 05C8 | OFF034 | 31:16 | — | — | — | — | — | — | — | — | — | — | — | — | — | — | — | VOFF<17:16> | 0000 |
| | | 15:0 | VOFF<15:1> | | | | | | | | | | | | | | | — | 0000 |
| 05CC | OFF035 | 31:16 | — | — | — | — | — | — | — | — | — | — | — | — | — | — | — | VOFF<17:16> | 0000 |
| | | 15:0 | VOFF<15:1> | | | | | | | | | | | | | | | — | 0000 |
| 05D0 | OFF036 | 31:16 | — | — | — | — | — | — | — | — | — | — | — | — | — | — | — | VOFF<17:16> | 0000 |
| | | 15:0 | VOFF<15:1> | | | | | | | | | | | | | | | — | 0000 |
| 05D4 | OFF037 | 31:16 | — | — | — | — | — | — | — | — | — | — | — | — | — | — | — | VOFF<17:16> | 0000 |
| | | 15:0 | VOFF<15:1> | | | | | | | | | | | | | | | — | 0000 |
| 05D8 | OFF038 | 31:16 | — | — | — | — | — | — | — | — | — | — | — | — | — | — | — | VOFF<17:16> | 0000 |
| | | 15:0 | VOFF<15:1> | | | | | | | | | | | | | | | — | 0000 |
| 05DC | OFF039 | 31:16 | — | — | — | — | — | — | — | — | — | — | — | — | — | — | — | VOFF<17:16> | 0000 |
| | | 15:0 | VOFF<15:1> | | | | | | | | | | | | | | | — | 0000 |
| 05E0 | OFF040 | 31:16 | — | — | — | — | — | — | — | — | — | — | — | — | — | — | — | VOFF<17:16> | 0000 |
| | | 15:0 | VOFF<15:1> | | | | | | | | | | | | | | | — | 0000 |
| 05E4 | OFF041 | 31:16 | — | — | — | — | — | — | — | — | — | — | — | — | — | — | — | VOFF<17:16> | 0000 |
| | | 15:0 | VOFF<15:1> | | | | | | | | | | | | | | | — | 0000 |
| 05E8 | OFF042 | 31:16 | — | — | — | — | — | — | — | — | — | — | — | — | — | — | — | VOFF<17:16> | 0000 |
| | | 15:0 | VOFF<15:1> | | | | | | | | | | | | | | | — | 0000 |
| 05EC | OFF043 | 31:16 | — | — | — | — | — | — | — | — | — | — | — | — | — | — | — | VOFF<17:16> | 0000 |
| | | 15:0 | VOFF<15:1> | | | | | | | | | | | | | | | — | 0000 |
| 05F0 | OFF044 | 31:16 | — | — | — | — | — | — | — | — | — | — | — | — | — | — | — | VOFF<17:16> | 0000 |
| | | 15:0 | VOFF<15:1> | | | | | | | | | | | | | | | — | 0000 |
| 05F4 | OFF045 | 31:16 | — | — | — | — | — | — | — | — | — | — | — | — | — | — | — | VOFF<17:16> | 0000 |
| | | 15:0 | VOFF<15:1> | | | | | | | | | | | | | | | — | 0000 |
| 05F8 | OFF046 | 31:16 | — | — | — | — | — | — | — | — | — | — | — | — | — | — | — | VOFF<17:16> | 0000 |
| | | 15:0 | VOFF<15:1> | | | | | | | | | | | | | | | — | 0000 |

Legend: x = unknown value on Reset; — = unimplemented, read as '0'. Reset values are shown in hexadecimal.

- Note**
- 1: All registers in this table with the exception of the OFFx registers, have corresponding CLR, SET, and INV registers at their virtual addresses, plus offsets of 0x4, 0x8 and 0xC, respectively. See [Section 12.3 “CLR, SET, and INV Registers”](#) for more information.
 - 2: This bit or register is not available on 64-pin devices.
 - 3: This bit or register is not available on devices without a CAN module.
 - 4: This bit or register is not available on 100-pin devices.
 - 5: Bits 31 and 30 are not available on 64-pin and 100-pin devices; bits 29 through 14 are not available on 64-pin devices.
 - 6: Bits 31, 30, 29, and bits 5 through 0 are not available on 64-pin and 100-pin devices; bit 31 is not available on 124-pin devices; bit 22 is not available on 64-pin devices.
 - 7: This bit or register is not available on devices without a Crypto module.
 - 8: This bit or register is not available on 124-pin devices.

TABLE 7-3: INTERRUPT REGISTER MAP (CONTINUED)

| Virtual Address (BF81_#) | Register Name ⁽¹⁾ | Bit Range | Bits | | | | | | | | | | | | | | | All Resets | |
|-----------------------------|---------------------------------|--------------|------------|-------|-------|-------|-------|-------|------|------|------|------|------|------|------|------|------|---------------|------|
| | | | 31/15 | 30/14 | 29/13 | 28/12 | 27/11 | 26/10 | 25/9 | 24/8 | 23/7 | 22/6 | 21/5 | 20/4 | 19/3 | 18/2 | 17/1 | | 16/0 |
| 05FC | OFF047 | 31:16 | — | — | — | — | — | — | — | — | — | — | — | — | — | — | — | VOFF<17:16> | 0000 |
| | | 15:0 | VOFF<15:1> | | | | | | | | | | | | | | | — | 0000 |
| 0600 | OFF048 | 31:16 | — | — | — | — | — | — | — | — | — | — | — | — | — | — | — | VOFF<17:16> | 0000 |
| | | 15:0 | VOFF<15:1> | | | | | | | | | | | | | | | — | 0000 |
| 0604 | OFF049 | 31:16 | — | — | — | — | — | — | — | — | — | — | — | — | — | — | — | VOFF<17:16> | 0000 |
| | | 15:0 | VOFF<15:1> | | | | | | | | | | | | | | | — | 0000 |
| 0608 | OFF050 | 31:16 | — | — | — | — | — | — | — | — | — | — | — | — | — | — | — | VOFF<17:16> | 0000 |
| | | 15:0 | VOFF<15:1> | | | | | | | | | | | | | | | — | 0000 |
| 060C | OFF051 | 31:16 | — | — | — | — | — | — | — | — | — | — | — | — | — | — | — | VOFF<17:16> | 0000 |
| | | 15:0 | VOFF<15:1> | | | | | | | | | | | | | | | — | 0000 |
| 0610 | OFF052 | 31:16 | — | — | — | — | — | — | — | — | — | — | — | — | — | — | — | VOFF<17:16> | 0000 |
| | | 15:0 | VOFF<15:1> | | | | | | | | | | | | | | | — | 0000 |
| 0614 | OFF053 | 31:16 | — | — | — | — | — | — | — | — | — | — | — | — | — | — | — | VOFF<17:16> | 0000 |
| | | 15:0 | VOFF<15:1> | | | | | | | | | | | | | | | — | 0000 |
| 0618 | OFF054 | 31:16 | — | — | — | — | — | — | — | — | — | — | — | — | — | — | — | VOFF<17:16> | 0000 |
| | | 15:0 | VOFF<15:1> | | | | | | | | | | | | | | | — | 0000 |
| 061C | OFF055 | 31:16 | — | — | — | — | — | — | — | — | — | — | — | — | — | — | — | VOFF<17:16> | 0000 |
| | | 15:0 | VOFF<15:1> | | | | | | | | | | | | | | | — | 0000 |
| 0620 | OFF056 | 31:16 | — | — | — | — | — | — | — | — | — | — | — | — | — | — | — | VOFF<17:16> | 0000 |
| | | 15:0 | VOFF<15:1> | | | | | | | | | | | | | | | — | 0000 |
| 0624 | OFF057 | 31:16 | — | — | — | — | — | — | — | — | — | — | — | — | — | — | — | VOFF<17:16> | 0000 |
| | | 15:0 | VOFF<15:1> | | | | | | | | | | | | | | | — | 0000 |
| 0628 | OFF058 | 31:16 | — | — | — | — | — | — | — | — | — | — | — | — | — | — | — | VOFF<17:16> | 0000 |
| | | 15:0 | VOFF<15:1> | | | | | | | | | | | | | | | — | 0000 |
| 062C | OFF059 | 31:16 | — | — | — | — | — | — | — | — | — | — | — | — | — | — | — | VOFF<17:16> | 0000 |
| | | 15:0 | VOFF<15:1> | | | | | | | | | | | | | | | — | 0000 |
| 0630 | OFF060 | 31:16 | — | — | — | — | — | — | — | — | — | — | — | — | — | — | — | VOFF<17:16> | 0000 |
| | | 15:0 | VOFF<15:1> | | | | | | | | | | | | | | | — | 0000 |
| 0634 | OFF061 | 31:16 | — | — | — | — | — | — | — | — | — | — | — | — | — | — | — | VOFF<17:16> | 0000 |
| | | 15:0 | VOFF<15:1> | | | | | | | | | | | | | | | — | 0000 |

Legend: x = unknown value on Reset; — = unimplemented, read as '0'. Reset values are shown in hexadecimal.

- Note**
- 1: All registers in this table with the exception of the OFFx registers, have corresponding CLR, SET, and INV registers at their virtual addresses, plus offsets of 0x4, 0x8 and 0xC, respectively. See [Section 12.3 “CLR, SET, and INV Registers”](#) for more information.
 - 2: This bit or register is not available on 64-pin devices.
 - 3: This bit or register is not available on devices without a CAN module.
 - 4: This bit or register is not available on 100-pin devices.
 - 5: Bits 31 and 30 are not available on 64-pin and 100-pin devices; bits 29 through 14 are not available on 64-pin devices.
 - 6: Bits 31, 30, 29, and bits 5 through 0 are not available on 64-pin and 100-pin devices; bit 31 is not available on 124-pin devices; bit 22 is not available on 64-pin devices.
 - 7: This bit or register is not available on devices without a Crypto module.
 - 8: This bit or register is not available on 124-pin devices.

TABLE 7-3: INTERRUPT REGISTER MAP (CONTINUED)

| Virtual Address (BF81_#) | Register Name ⁽¹⁾ | Bit Range | Bits | | | | | | | | | | | | | | All Resets | |
|-----------------------------|---------------------------------|-----------|------------|-------|-------|-------|-------|-------|------|------|------|------|------|------|------|------|-------------|------|
| | | | 31/15 | 30/14 | 29/13 | 28/12 | 27/11 | 26/10 | 25/9 | 24/8 | 23/7 | 22/6 | 21/5 | 20/4 | 19/3 | 18/2 | | 17/1 |
| 0638 | OFF062 | 31:16 | — | — | — | — | — | — | — | — | — | — | — | — | — | — | VOFF<17:16> | 0000 |
| | | 15:0 | VOFF<15:1> | | | | | | | | | | | | | | — | 0000 |
| 063C | OFF063 | 31:16 | — | — | — | — | — | — | — | — | — | — | — | — | — | — | VOFF<17:16> | 0000 |
| | | 15:0 | VOFF<15:1> | | | | | | | | | | | | | | — | 0000 |
| 0640 | OFF064 | 31:16 | — | — | — | — | — | — | — | — | — | — | — | — | — | — | VOFF<17:16> | 0000 |
| | | 15:0 | VOFF<15:1> | | | | | | | | | | | | | | — | 0000 |
| 0644 | OFF065 | 31:16 | — | — | — | — | — | — | — | — | — | — | — | — | — | — | VOFF<17:16> | 0000 |
| | | 15:0 | VOFF<15:1> | | | | | | | | | | | | | | — | 0000 |
| 0648 | OFF066 | 31:16 | — | — | — | — | — | — | — | — | — | — | — | — | — | — | VOFF<17:16> | 0000 |
| | | 15:0 | VOFF<15:1> | | | | | | | | | | | | | | — | 0000 |
| 064C | OFF067 | 31:16 | — | — | — | — | — | — | — | — | — | — | — | — | — | — | VOFF<17:16> | 0000 |
| | | 15:0 | VOFF<15:1> | | | | | | | | | | | | | | — | 0000 |
| 0650 | OFF068 | 31:16 | — | — | — | — | — | — | — | — | — | — | — | — | — | — | VOFF<17:16> | 0000 |
| | | 15:0 | VOFF<15:1> | | | | | | | | | | | | | | — | 0000 |
| 0654 | OFF069 | 31:16 | — | — | — | — | — | — | — | — | — | — | — | — | — | — | VOFF<17:16> | 0000 |
| | | 15:0 | VOFF<15:1> | | | | | | | | | | | | | | — | 0000 |
| 0658 | OFF070 | 31:16 | — | — | — | — | — | — | — | — | — | — | — | — | — | — | VOFF<17:16> | 0000 |
| | | 15:0 | VOFF<15:1> | | | | | | | | | | | | | | — | 0000 |
| 065C | OFF071 | 31:16 | — | — | — | — | — | — | — | — | — | — | — | — | — | — | VOFF<17:16> | 0000 |
| | | 15:0 | VOFF<15:1> | | | | | | | | | | | | | | — | 0000 |
| 0660 | OFF072 | 31:16 | — | — | — | — | — | — | — | — | — | — | — | — | — | — | VOFF<17:16> | 0000 |
| | | 15:0 | VOFF<15:1> | | | | | | | | | | | | | | — | 0000 |
| 0664 | OFF073 | 31:16 | — | — | — | — | — | — | — | — | — | — | — | — | — | — | VOFF<17:16> | 0000 |
| | | 15:0 | VOFF<15:1> | | | | | | | | | | | | | | — | 0000 |
| 0668 | OFF074 | 31:16 | — | — | — | — | — | — | — | — | — | — | — | — | — | — | VOFF<17:16> | 0000 |
| | | 15:0 | VOFF<15:1> | | | | | | | | | | | | | | — | 0000 |
| 066C | OFF075 | 31:16 | — | — | — | — | — | — | — | — | — | — | — | — | — | — | VOFF<17:16> | 0000 |
| | | 15:0 | VOFF<15:1> | | | | | | | | | | | | | | — | 0000 |
| 0670 | OFF076 | 31:16 | — | — | — | — | — | — | — | — | — | — | — | — | — | — | VOFF<17:16> | 0000 |
| | | 15:0 | VOFF<15:1> | | | | | | | | | | | | | | — | 0000 |

Legend: x = unknown value on Reset; — = unimplemented, read as '0'. Reset values are shown in hexadecimal.

- Note**
- 1: All registers in this table with the exception of the OFFx registers, have corresponding CLR, SET, and INV registers at their virtual addresses, plus offsets of 0x4, 0x8 and 0xC, respectively. See [Section 12.3 "CLR, SET, and INV Registers"](#) for more information.
 - 2: This bit or register is not available on 64-pin devices.
 - 3: This bit or register is not available on devices without a CAN module.
 - 4: This bit or register is not available on 100-pin devices.
 - 5: Bits 31 and 30 are not available on 64-pin and 100-pin devices; bits 29 through 14 are not available on 64-pin devices.
 - 6: Bits 31, 30, 29, and bits 5 through 0 are not available on 64-pin and 100-pin devices; bit 31 is not available on 124-pin devices; bit 22 is not available on 64-pin devices.
 - 7: This bit or register is not available on devices without a Crypto module.
 - 8: This bit or register is not available on 124-pin devices.

TABLE 7-3: INTERRUPT REGISTER MAP (CONTINUED)

| Virtual Address (BF81_#) | Register Name ⁽¹⁾ | Bit Range | Bits | | | | | | | | | | | | | | | All Resets | |
|-----------------------------|---------------------------------|--------------|------------|-------|-------|-------|-------|-------|------|------|------|------|------|------|------|------|------|---------------|------|
| | | | 31/15 | 30/14 | 29/13 | 28/12 | 27/11 | 26/10 | 25/9 | 24/8 | 23/7 | 22/6 | 21/5 | 20/4 | 19/3 | 18/2 | 17/1 | | 16/0 |
| 0674 | OFF077 ⁽²⁾ | 31:16 | — | — | — | — | — | — | — | — | — | — | — | — | — | — | — | VOFF<17:16> | 0000 |
| | | 15:0 | VOFF<15:1> | | | | | | | | | | | | | | | — | 0000 |
| 0678 | OFF078 ⁽²⁾ | 31:16 | — | — | — | — | — | — | — | — | — | — | — | — | — | — | — | VOFF<17:16> | 0000 |
| | | 15:0 | VOFF<15:1> | | | | | | | | | | | | | | | — | 0000 |
| 067C | OFF079 ⁽²⁾ | 31:16 | — | — | — | — | — | — | — | — | — | — | — | — | — | — | — | VOFF<17:16> | 0000 |
| | | 15:0 | VOFF<15:1> | | | | | | | | | | | | | | | — | 0000 |
| 0680 | OFF080 ⁽²⁾ | 31:16 | — | — | — | — | — | — | — | — | — | — | — | — | — | — | — | VOFF<17:16> | 0000 |
| | | 15:0 | VOFF<15:1> | | | | | | | | | | | | | | | — | 0000 |
| 0684 | OFF081 ⁽²⁾ | 31:16 | — | — | — | — | — | — | — | — | — | — | — | — | — | — | — | VOFF<17:16> | 0000 |
| | | 15:0 | VOFF<15:1> | | | | | | | | | | | | | | | — | 0000 |
| 0688 | OFF082 ⁽²⁾ | 31:16 | — | — | — | — | — | — | — | — | — | — | — | — | — | — | — | VOFF<17:16> | 0000 |
| | | 15:0 | VOFF<15:1> | | | | | | | | | | | | | | | — | 0000 |
| 068C | OFF083 ⁽²⁾ | 31:16 | — | — | — | — | — | — | — | — | — | — | — | — | — | — | — | VOFF<17:16> | 0000 |
| | | 15:0 | VOFF<15:1> | | | | | | | | | | | | | | | — | 0000 |
| 0690 | OFF084 ⁽²⁾ | 31:16 | — | — | — | — | — | — | — | — | — | — | — | — | — | — | — | VOFF<17:16> | 0000 |
| | | 15:0 | VOFF<15:1> | | | | | | | | | | | | | | | — | 0000 |
| 0694 | OFF085 ⁽²⁾ | 31:16 | — | — | — | — | — | — | — | — | — | — | — | — | — | — | — | VOFF<17:16> | 0000 |
| | | 15:0 | VOFF<15:1> | | | | | | | | | | | | | | | — | 0000 |
| 0698 | OFF086 ⁽²⁾ | 31:16 | — | — | — | — | — | — | — | — | — | — | — | — | — | — | — | VOFF<17:16> | 0000 |
| | | 15:0 | VOFF<15:1> | | | | | | | | | | | | | | | — | 0000 |
| 069C | OFF087 ⁽²⁾ | 31:16 | — | — | — | — | — | — | — | — | — | — | — | — | — | — | — | VOFF<17:16> | 0000 |
| | | 15:0 | VOFF<15:1> | | | | | | | | | | | | | | | — | 0000 |
| 06A0 | OFF088 ⁽²⁾ | 31:16 | — | — | — | — | — | — | — | — | — | — | — | — | — | — | — | VOFF<17:16> | 0000 |
| | | 15:0 | VOFF<15:1> | | | | | | | | | | | | | | | — | 0000 |
| 06A4 | OFF089 ⁽²⁾ | 31:16 | — | — | — | — | — | — | — | — | — | — | — | — | — | — | — | VOFF<17:16> | 0000 |
| | | 15:0 | VOFF<15:1> | | | | | | | | | | | | | | | — | 0000 |
| 06A8 | OFF090 ⁽²⁾ | 31:16 | — | — | — | — | — | — | — | — | — | — | — | — | — | — | — | VOFF<17:16> | 0000 |
| | | 15:0 | VOFF<15:1> | | | | | | | | | | | | | | | — | 0000 |
| 06AC | OFF091 ⁽²⁾ | 31:16 | — | — | — | — | — | — | — | — | — | — | — | — | — | — | — | VOFF<17:16> | 0000 |
| | | 15:0 | VOFF<15:1> | | | | | | | | | | | | | | | — | 0000 |

Legend: x = unknown value on Reset; — = unimplemented, read as '0'. Reset values are shown in hexadecimal.

- Note**
- 1: All registers in this table with the exception of the OFFx registers, have corresponding CLR, SET, and INV registers at their virtual addresses, plus offsets of 0x4, 0x8 and 0xC, respectively. See [Section 12.3 “CLR, SET, and INV Registers”](#) for more information.
 - 2: This bit or register is not available on 64-pin devices.
 - 3: This bit or register is not available on devices without a CAN module.
 - 4: This bit or register is not available on 100-pin devices.
 - 5: Bits 31 and 30 are not available on 64-pin and 100-pin devices; bits 29 through 14 are not available on 64-pin devices.
 - 6: Bits 31, 30, 29, and bits 5 through 0 are not available on 64-pin and 100-pin devices; bit 31 is not available on 124-pin devices; bit 22 is not available on 64-pin devices.
 - 7: This bit or register is not available on devices without a Crypto module.
 - 8: This bit or register is not available on 124-pin devices.

TABLE 7-3: INTERRUPT REGISTER MAP (CONTINUED)

| Virtual Address (BF81_#) | Register Name ⁽¹⁾ | Bit Range | Bits | | | | | | | | | | | | | | | All Resets |
|-----------------------------|---------------------------------|-----------|------------|-------|-------|-------|-------|-------|------|------|------|------|------|------|------|------|-------------|------------|
| | | | 31/15 | 30/14 | 29/13 | 28/12 | 27/11 | 26/10 | 25/9 | 24/8 | 23/7 | 22/6 | 21/5 | 20/4 | 19/3 | 18/2 | 17/1 | |
| 06B0 | OFF092 ⁽²⁾ | 31:16 | — | — | — | — | — | — | — | — | — | — | — | — | — | — | VOFF<17:16> | 0000 |
| | | 15:0 | VOFF<15:1> | | | | | | | | | | | | | | | — |
| 06B4 | OFF093 ⁽²⁾ | 31:16 | — | — | — | — | — | — | — | — | — | — | — | — | — | — | VOFF<17:16> | 0000 |
| | | 15:0 | VOFF<15:1> | | | | | | | | | | | | | | | — |
| 06B8 | OFF094 ^(2,4) | 31:16 | — | — | — | — | — | — | — | — | — | — | — | — | — | — | VOFF<17:16> | 0000 |
| | | 15:0 | VOFF<15:1> | | | | | | | | | | | | | | | — |
| 06BC | OFF095 ^(2,4) | 31:16 | — | — | — | — | — | — | — | — | — | — | — | — | — | — | VOFF<17:16> | 0000 |
| | | 15:0 | VOFF<15:1> | | | | | | | | | | | | | | | — |
| 06C0 | OFF096 ^(2,4) | 31:16 | — | — | — | — | — | — | — | — | — | — | — | — | — | — | VOFF<17:16> | 0000 |
| | | 15:0 | VOFF<15:1> | | | | | | | | | | | | | | | — |
| 06C4 | OFF097 ^(2,4) | 31:16 | — | — | — | — | — | — | — | — | — | — | — | — | — | — | VOFF<17:16> | 0000 |
| | | 15:0 | VOFF<15:1> | | | | | | | | | | | | | | | — |
| 06C8 | OFF098 ^(2,4) | 31:16 | — | — | — | — | — | — | — | — | — | — | — | — | — | — | VOFF<17:16> | 0000 |
| | | 15:0 | VOFF<15:1> | | | | | | | | | | | | | | | — |
| 06CC | OFF099 ^(2,4) | 31:16 | — | — | — | — | — | — | — | — | — | — | — | — | — | — | VOFF<17:16> | 0000 |
| | | 15:0 | VOFF<15:1> | | | | | | | | | | | | | | | — |
| 06D0 | OFF100 ^(2,4) | 31:16 | — | — | — | — | — | — | — | — | — | — | — | — | — | — | VOFF<17:16> | 0000 |
| | | 15:0 | VOFF<15:1> | | | | | | | | | | | | | | | — |
| 06D4 | OFF101 ^(2,4) | 31:16 | — | — | — | — | — | — | — | — | — | — | — | — | — | — | VOFF<17:16> | 0000 |
| | | 15:0 | VOFF<15:1> | | | | | | | | | | | | | | | — |
| 06D8 | OFF102 | 31:16 | — | — | — | — | — | — | — | — | — | — | — | — | — | — | VOFF<17:16> | 0000 |
| | | 15:0 | VOFF<15:1> | | | | | | | | | | | | | | | — |
| 06DC | OFF103 | 31:16 | — | — | — | — | — | — | — | — | — | — | — | — | — | — | VOFF<17:16> | 0000 |
| | | 15:0 | VOFF<15:1> | | | | | | | | | | | | | | | — |
| 06E0 | OFF104 | 31:16 | — | — | — | — | — | — | — | — | — | — | — | — | — | — | VOFF<17:16> | 0000 |
| | | 15:0 | VOFF<15:1> | | | | | | | | | | | | | | | — |
| 06E4 | OFF105 | 31:16 | — | — | — | — | — | — | — | — | — | — | — | — | — | — | VOFF<17:16> | 0000 |
| | | 15:0 | VOFF<15:1> | | | | | | | | | | | | | | | — |
| 06E8 | OFF106 | 31:16 | — | — | — | — | — | — | — | — | — | — | — | — | — | — | VOFF<17:16> | 0000 |
| | | 15:0 | VOFF<15:1> | | | | | | | | | | | | | | | — |

Legend: x = unknown value on Reset; — = unimplemented, read as '0'. Reset values are shown in hexadecimal.

- Note**
- 1: All registers in this table with the exception of the OFFx registers, have corresponding CLR, SET, and INV registers at their virtual addresses, plus offsets of 0x4, 0x8 and 0xC, respectively. See [Section 12.3 “CLR, SET, and INV Registers”](#) for more information.
 - 2: This bit or register is not available on 64-pin devices.
 - 3: This bit or register is not available on devices without a CAN module.
 - 4: This bit or register is not available on 100-pin devices.
 - 5: Bits 31 and 30 are not available on 64-pin and 100-pin devices; bits 29 through 14 are not available on 64-pin devices.
 - 6: Bits 31, 30, 29, and bits 5 through 0 are not available on 64-pin and 100-pin devices; bit 31 is not available on 124-pin devices; bit 22 is not available on 64-pin devices.
 - 7: This bit or register is not available on devices without a Crypto module.
 - 8: This bit or register is not available on 124-pin devices.

TABLE 7-3: INTERRUPT REGISTER MAP (CONTINUED)

| Virtual Address (BF81_#) | Register Name ⁽¹⁾ | Bit Range | Bits | | | | | | | | | | | | | | | All Resets | |
|-----------------------------|---------------------------------|--------------|------------|-------|-------|-------|-------|-------|------|------|------|------|------|------|------|------|------|---------------|------|
| | | | 31/15 | 30/14 | 29/13 | 28/12 | 27/11 | 26/10 | 25/9 | 24/8 | 23/7 | 22/6 | 21/5 | 20/4 | 19/3 | 18/2 | 17/1 | | 16/0 |
| 06EC | OFF107 ⁽⁷⁾ | 31:16 | — | — | — | — | — | — | — | — | — | — | — | — | — | — | — | VOFF<17:16> | 0000 |
| | | 15:0 | VOFF<15:1> | | | | | | | | | | | | | | | — | 0000 |
| 06F4 | OFF109 | 31:16 | — | — | — | — | — | — | — | — | — | — | — | — | — | — | — | VOFF<17:16> | 0000 |
| | | 15:0 | VOFF<15:1> | | | | | | | | | | | | | | | — | 0000 |
| 06F8 | OFF110 | 31:16 | — | — | — | — | — | — | — | — | — | — | — | — | — | — | — | VOFF<17:16> | 0000 |
| | | 15:0 | VOFF<15:1> | | | | | | | | | | | | | | | — | 0000 |
| 06FC | OFF111 | 31:16 | — | — | — | — | — | — | — | — | — | — | — | — | — | — | — | VOFF<17:16> | 0000 |
| | | 15:0 | VOFF<15:1> | | | | | | | | | | | | | | | — | 0000 |
| 0700 | OFF112 | 31:16 | — | — | — | — | — | — | — | — | — | — | — | — | — | — | — | VOFF<17:16> | 0000 |
| | | 15:0 | VOFF<15:1> | | | | | | | | | | | | | | | — | 0000 |
| 0704 | OFF113 | 31:16 | — | — | — | — | — | — | — | — | — | — | — | — | — | — | — | VOFF<17:16> | 0000 |
| | | 15:0 | VOFF<15:1> | | | | | | | | | | | | | | | — | 0000 |
| 0708 | OFF114 | 31:16 | — | — | — | — | — | — | — | — | — | — | — | — | — | — | — | VOFF<17:16> | 0000 |
| | | 15:0 | VOFF<15:1> | | | | | | | | | | | | | | | — | 0000 |
| 070C | OFF115 | 31:16 | — | — | — | — | — | — | — | — | — | — | — | — | — | — | — | VOFF<17:16> | 0000 |
| | | 15:0 | VOFF<15:1> | | | | | | | | | | | | | | | — | 0000 |
| 0710 | OFF116 | 31:16 | — | — | — | — | — | — | — | — | — | — | — | — | — | — | — | VOFF<17:16> | 0000 |
| | | 15:0 | VOFF<15:1> | | | | | | | | | | | | | | | — | 0000 |
| 0714 | OFF117 | 31:16 | — | — | — | — | — | — | — | — | — | — | — | — | — | — | — | VOFF<17:16> | 0000 |
| | | 15:0 | VOFF<15:1> | | | | | | | | | | | | | | | — | 0000 |
| 0718 | OFF118 ⁽²⁾ | 31:16 | — | — | — | — | — | — | — | — | — | — | — | — | — | — | — | VOFF<17:16> | 0000 |
| | | 15:0 | VOFF<15:1> | | | | | | | | | | | | | | | — | 0000 |
| 071C | OFF119 | 31:16 | — | — | — | — | — | — | — | — | — | — | — | — | — | — | — | VOFF<17:16> | 0000 |
| | | 15:0 | VOFF<15:1> | | | | | | | | | | | | | | | — | 0000 |
| 0720 | OFF120 | 31:16 | — | — | — | — | — | — | — | — | — | — | — | — | — | — | — | VOFF<17:16> | 0000 |
| | | 15:0 | VOFF<15:1> | | | | | | | | | | | | | | | — | 0000 |
| 0724 | OFF121 | 31:16 | — | — | — | — | — | — | — | — | — | — | — | — | — | — | — | VOFF<17:16> | 0000 |
| | | 15:0 | VOFF<15:1> | | | | | | | | | | | | | | | — | 0000 |
| 0728 | OFF122 | 31:16 | — | — | — | — | — | — | — | — | — | — | — | — | — | — | — | VOFF<17:16> | 0000 |
| | | 15:0 | VOFF<15:1> | | | | | | | | | | | | | | | — | 0000 |

Legend: x = unknown value on Reset; — = unimplemented, read as '0'. Reset values are shown in hexadecimal.

- Note**
- 1: All registers in this table with the exception of the OFFx registers, have corresponding CLR, SET, and INV registers at their virtual addresses, plus offsets of 0x4, 0x8 and 0xC, respectively. See [Section 12.3 “CLR, SET, and INV Registers”](#) for more information.
 - 2: This bit or register is not available on 64-pin devices.
 - 3: This bit or register is not available on devices without a CAN module.
 - 4: This bit or register is not available on 100-pin devices.
 - 5: Bits 31 and 30 are not available on 64-pin and 100-pin devices; bits 29 through 14 are not available on 64-pin devices.
 - 6: Bits 31, 30, 29, and bits 5 through 0 are not available on 64-pin and 100-pin devices; bit 31 is not available on 124-pin devices; bit 22 is not available on 64-pin devices.
 - 7: This bit or register is not available on devices without a Crypto module.
 - 8: This bit or register is not available on 124-pin devices.

TABLE 7-3: INTERRUPT REGISTER MAP (CONTINUED)

| Virtual Address (BF81_#) | Register Name ⁽¹⁾ | Bit Range | Bits | | | | | | | | | | | | | | All Resets | |
|-----------------------------|---------------------------------|-----------|------------|-------|-------|-------|-------|-------|------|------|------|------|------|------|------|------|-------------|------|
| | | | 31/15 | 30/14 | 29/13 | 28/12 | 27/11 | 26/10 | 25/9 | 24/8 | 23/7 | 22/6 | 21/5 | 20/4 | 19/3 | 18/2 | | 17/1 |
| 072C | OFF123 | 31:16 | — | — | — | — | — | — | — | — | — | — | — | — | — | — | VOFF<17:16> | 0000 |
| | | 15:0 | VOFF<15:1> | | | | | | | | | | | | | | — | 0000 |
| 0730 | OFF124 | 31:16 | — | — | — | — | — | — | — | — | — | — | — | — | — | — | VOFF<17:16> | 0000 |
| | | 15:0 | VOFF<15:1> | | | | | | | | | | | | | | — | 0000 |
| 0734 | OFF125 ^(2,4) | 31:16 | — | — | — | — | — | — | — | — | — | — | — | — | — | — | VOFF<17:16> | 0000 |
| | | 15:0 | VOFF<15:1> | | | | | | | | | | | | | | — | 0000 |
| 0738 | OFF126 ^(2,4) | 31:16 | — | — | — | — | — | — | — | — | — | — | — | — | — | — | VOFF<17:16> | 0000 |
| | | 15:0 | VOFF<15:1> | | | | | | | | | | | | | | — | 0000 |
| 073C | OFF127 ^(2,4,8) | 31:16 | — | — | — | — | — | — | — | — | — | — | — | — | — | — | VOFF<17:16> | 0000 |
| | | 15:0 | VOFF<15:1> | | | | | | | | | | | | | | — | 0000 |
| 0740 | OFF128 | 31:16 | — | — | — | — | — | — | — | — | — | — | — | — | — | — | VOFF<17:16> | 0000 |
| | | 15:0 | VOFF<15:1> | | | | | | | | | | | | | | — | 0000 |
| 0744 | OFF129 | 31:16 | — | — | — | — | — | — | — | — | — | — | — | — | — | — | VOFF<17:16> | 0000 |
| | | 15:0 | VOFF<15:1> | | | | | | | | | | | | | | — | 0000 |
| 0748 | OFF130 | 31:16 | — | — | — | — | — | — | — | — | — | — | — | — | — | — | VOFF<17:16> | 0000 |
| | | 15:0 | VOFF<15:1> | | | | | | | | | | | | | | — | 0000 |
| 074C | OFF131 | 31:16 | — | — | — | — | — | — | — | — | — | — | — | — | — | — | VOFF<17:16> | 0000 |
| | | 15:0 | VOFF<15:1> | | | | | | | | | | | | | | — | 0000 |
| 0750 | OFF132 | 31:16 | — | — | — | — | — | — | — | — | — | — | — | — | — | — | VOFF<17:16> | 0000 |
| | | 15:0 | VOFF<15:1> | | | | | | | | | | | | | | — | 0000 |
| 0754 | OFF133 | 31:16 | — | — | — | — | — | — | — | — | — | — | — | — | — | — | VOFF<17:16> | 0000 |
| | | 15:0 | VOFF<15:1> | | | | | | | | | | | | | | — | 0000 |
| 0758 | OFF134 | 31:16 | — | — | — | — | — | — | — | — | — | — | — | — | — | — | VOFF<17:16> | 0000 |
| | | 15:0 | VOFF<15:1> | | | | | | | | | | | | | | — | 0000 |
| 075C | OFF135 | 31:16 | — | — | — | — | — | — | — | — | — | — | — | — | — | — | VOFF<17:16> | 0000 |
| | | 15:0 | VOFF<15:1> | | | | | | | | | | | | | | — | 0000 |
| 0760 | OFF136 | 31:16 | — | — | — | — | — | — | — | — | — | — | — | — | — | — | VOFF<17:16> | 0000 |
| | | 15:0 | VOFF<15:1> | | | | | | | | | | | | | | — | 0000 |
| 0764 | OFF137 | 31:16 | — | — | — | — | — | — | — | — | — | — | — | — | — | — | VOFF<17:16> | 0000 |
| | | 15:0 | VOFF<15:1> | | | | | | | | | | | | | | — | 0000 |

Legend: x = unknown value on Reset; — = unimplemented, read as '0'. Reset values are shown in hexadecimal.

- Note**
- 1: All registers in this table with the exception of the OFFx registers, have corresponding CLR, SET, and INV registers at their virtual addresses, plus offsets of 0x4, 0x8 and 0xC, respectively. See [Section 12.3 “CLR, SET, and INV Registers”](#) for more information.
 - 2: This bit or register is not available on 64-pin devices.
 - 3: This bit or register is not available on devices without a CAN module.
 - 4: This bit or register is not available on 100-pin devices.
 - 5: Bits 31 and 30 are not available on 64-pin and 100-pin devices; bits 29 through 14 are not available on 64-pin devices.
 - 6: Bits 31, 30, 29, and bits 5 through 0 are not available on 64-pin and 100-pin devices; bit 31 is not available on 124-pin devices; bit 22 is not available on 64-pin devices.
 - 7: This bit or register is not available on devices without a Crypto module.
 - 8: This bit or register is not available on 124-pin devices.

TABLE 7-3: INTERRUPT REGISTER MAP (CONTINUED)

| Virtual Address (BF81_#) | Register Name ⁽¹⁾ | Bit Range | Bits | | | | | | | | | | | | | | | All Resets | |
|-----------------------------|---------------------------------|--------------|------------|-------|-------|-------|-------|-------|------|------|------|------|------|------|------|------|------|---------------|------|
| | | | 31/15 | 30/14 | 29/13 | 28/12 | 27/11 | 26/10 | 25/9 | 24/8 | 23/7 | 22/6 | 21/5 | 20/4 | 19/3 | 18/2 | 17/1 | | 16/0 |
| 0768 | OFF138 | 31:16 | — | — | — | — | — | — | — | — | — | — | — | — | — | — | — | VOFF<17:16> | 0000 |
| | | 15:0 | VOFF<15:1> | | | | | | | | | | | | | | | — | 0000 |
| 076C | OFF139 | 31:16 | — | — | — | — | — | — | — | — | — | — | — | — | — | — | — | VOFF<17:16> | 0000 |
| | | 15:0 | VOFF<15:1> | | | | | | | | | | | | | | | — | 0000 |
| 0770 | OFF140 | 31:16 | — | — | — | — | — | — | — | — | — | — | — | — | — | — | — | VOFF<17:16> | 0000 |
| | | 15:0 | VOFF<15:1> | | | | | | | | | | | | | | | — | 0000 |
| 0774 | OFF141 | 31:16 | — | — | — | — | — | — | — | — | — | — | — | — | — | — | — | VOFF<17:16> | 0000 |
| | | 15:0 | VOFF<15:1> | | | | | | | | | | | | | | | — | 0000 |
| 0778 | OFF142 | 31:16 | — | — | — | — | — | — | — | — | — | — | — | — | — | — | — | VOFF<17:16> | 0000 |
| | | 15:0 | VOFF<15:1> | | | | | | | | | | | | | | | — | 0000 |
| 077C | OFF143 | 31:16 | — | — | — | — | — | — | — | — | — | — | — | — | — | — | — | VOFF<17:16> | 0000 |
| | | 15:0 | VOFF<15:1> | | | | | | | | | | | | | | | — | 0000 |
| 0780 | OFF144 | 31:16 | — | — | — | — | — | — | — | — | — | — | — | — | — | — | — | VOFF<17:16> | 0000 |
| | | 15:0 | VOFF<15:1> | | | | | | | | | | | | | | | — | 0000 |
| 0784 | OFF145 | 31:16 | — | — | — | — | — | — | — | — | — | — | — | — | — | — | — | VOFF<17:16> | 0000 |
| | | 15:0 | VOFF<15:1> | | | | | | | | | | | | | | | — | 0000 |
| 0788 | OFF146 | 31:16 | — | — | — | — | — | — | — | — | — | — | — | — | — | — | — | VOFF<17:16> | 0000 |
| | | 15:0 | VOFF<15:1> | | | | | | | | | | | | | | | — | 0000 |
| 078C | OFF147 | 31:16 | — | — | — | — | — | — | — | — | — | — | — | — | — | — | — | VOFF<17:16> | 0000 |
| | | 15:0 | VOFF<15:1> | | | | | | | | | | | | | | | — | 0000 |
| 0790 | OFF148 ⁽²⁾ | 31:16 | — | — | — | — | — | — | — | — | — | — | — | — | — | — | — | VOFF<17:16> | 0000 |
| | | 15:0 | VOFF<15:1> | | | | | | | | | | | | | | | — | 0000 |
| 0794 | OFF149 ⁽²⁾ | 31:16 | — | — | — | — | — | — | — | — | — | — | — | — | — | — | — | VOFF<17:16> | 0000 |
| | | 15:0 | VOFF<15:1> | | | | | | | | | | | | | | | — | 0000 |
| 0798 | OFF150 ⁽²⁾ | 31:16 | — | — | — | — | — | — | — | — | — | — | — | — | — | — | — | VOFF<17:16> | 0000 |
| | | 15:0 | VOFF<15:1> | | | | | | | | | | | | | | | — | 0000 |
| 079C | OFF151 ⁽³⁾ | 31:16 | — | — | — | — | — | — | — | — | — | — | — | — | — | — | — | VOFF<17:16> | 0000 |
| | | 15:0 | VOFF<15:1> | | | | | | | | | | | | | | | — | 0000 |
| 07A0 | OFF152 ⁽³⁾ | 31:16 | — | — | — | — | — | — | — | — | — | — | — | — | — | — | — | VOFF<17:16> | 0000 |
| | | 15:0 | VOFF<15:1> | | | | | | | | | | | | | | | — | 0000 |

Legend: x = unknown value on Reset; — = unimplemented, read as '0'. Reset values are shown in hexadecimal.

- Note**
- 1: All registers in this table with the exception of the OFFx registers, have corresponding CLR, SET, and INV registers at their virtual addresses, plus offsets of 0x4, 0x8 and 0xC, respectively. See [Section 12.3 “CLR, SET, and INV Registers”](#) for more information.
 - 2: This bit or register is not available on 64-pin devices.
 - 3: This bit or register is not available on devices without a CAN module.
 - 4: This bit or register is not available on 100-pin devices.
 - 5: Bits 31 and 30 are not available on 64-pin and 100-pin devices; bits 29 through 14 are not available on 64-pin devices.
 - 6: Bits 31, 30, 29, and bits 5 through 0 are not available on 64-pin and 100-pin devices; bit 31 is not available on 124-pin devices; bit 22 is not available on 64-pin devices.
 - 7: This bit or register is not available on devices without a Crypto module.
 - 8: This bit or register is not available on 124-pin devices.

TABLE 7-3: INTERRUPT REGISTER MAP (CONTINUED)

| Virtual Address (BF81_#) | Register Name ⁽¹⁾ | Bit Range | Bits | | | | | | | | | | | | | | | All Resets |
|-----------------------------|---------------------------------|-----------|------------|-------|-------|-------|-------|-------|------|------|------|------|------|------|------|------|-------------|------------|
| | | | 31/15 | 30/14 | 29/13 | 28/12 | 27/11 | 26/10 | 25/9 | 24/8 | 23/7 | 22/6 | 21/5 | 20/4 | 19/3 | 18/2 | 17/1 | |
| 07A4 | OFF153 | 31:16 | — | — | — | — | — | — | — | — | — | — | — | — | — | — | VOFF<17:16> | 0000 |
| | | 15:0 | VOFF<15:1> | | | | | | | | | | | | | | | — |
| 07A8 | OFF154 | 31:16 | — | — | — | — | — | — | — | — | — | — | — | — | — | — | VOFF<17:16> | 0000 |
| | | 15:0 | VOFF<15:1> | | | | | | | | | | | | | | | — |
| 07AC | OFF155 | 31:16 | — | — | — | — | — | — | — | — | — | — | — | — | — | — | VOFF<17:16> | 0000 |
| | | 15:0 | VOFF<15:1> | | | | | | | | | | | | | | | — |
| 07B0 | OFF156 | 31:16 | — | — | — | — | — | — | — | — | — | — | — | — | — | — | VOFF<17:16> | 0000 |
| | | 15:0 | VOFF<15:1> | | | | | | | | | | | | | | | — |
| 07B4 | OFF157 | 31:16 | — | — | — | — | — | — | — | — | — | — | — | — | — | — | VOFF<17:16> | 0000 |
| | | 15:0 | VOFF<15:1> | | | | | | | | | | | | | | | — |
| 07B8 | OFF158 | 31:16 | — | — | — | — | — | — | — | — | — | — | — | — | — | — | VOFF<17:16> | 0000 |
| | | 15:0 | VOFF<15:1> | | | | | | | | | | | | | | | — |
| 07BC | OFF159 | 31:16 | — | — | — | — | — | — | — | — | — | — | — | — | — | — | VOFF<17:16> | 0000 |
| | | 15:0 | VOFF<15:1> | | | | | | | | | | | | | | | — |
| 07C0 | OFF160 | 31:16 | — | — | — | — | — | — | — | — | — | — | — | — | — | — | VOFF<17:16> | 0000 |
| | | 15:0 | VOFF<15:1> | | | | | | | | | | | | | | | — |
| 07C4 | OFF161 | 31:16 | — | — | — | — | — | — | — | — | — | — | — | — | — | — | VOFF<17:16> | 0000 |
| | | 15:0 | VOFF<15:1> | | | | | | | | | | | | | | | — |
| 07C8 | OFF162 | 31:16 | — | — | — | — | — | — | — | — | — | — | — | — | — | — | VOFF<17:16> | 0000 |
| | | 15:0 | VOFF<15:1> | | | | | | | | | | | | | | | — |
| 07CC | OFF163 | 31:16 | — | — | — | — | — | — | — | — | — | — | — | — | — | — | VOFF<17:16> | 0000 |
| | | 15:0 | VOFF<15:1> | | | | | | | | | | | | | | | — |
| 07D0 | OFF164 | 31:16 | — | — | — | — | — | — | — | — | — | — | — | — | — | — | VOFF<17:16> | 0000 |
| | | 15:0 | VOFF<15:1> | | | | | | | | | | | | | | | — |
| 07D4 | OFF165 | 31:16 | — | — | — | — | — | — | — | — | — | — | — | — | — | — | VOFF<17:16> | 0000 |
| | | 15:0 | VOFF<15:1> | | | | | | | | | | | | | | | — |
| 07D8 | OFF166 | 31:16 | — | — | — | — | — | — | — | — | — | — | — | — | — | — | VOFF<17:16> | 0000 |
| | | 15:0 | VOFF<15:1> | | | | | | | | | | | | | | | — |
| 07DC | OFF167 | 31:16 | — | — | — | — | — | — | — | — | — | — | — | — | — | — | VOFF<17:16> | 0000 |
| | | 15:0 | VOFF<15:1> | | | | | | | | | | | | | | | — |

Legend: x = unknown value on Reset; — = unimplemented, read as '0'. Reset values are shown in hexadecimal.

- Note**
- 1: All registers in this table with the exception of the OFFx registers, have corresponding CLR, SET, and INV registers at their virtual addresses, plus offsets of 0x4, 0x8 and 0xC, respectively. See [Section 12.3 "CLR, SET, and INV Registers"](#) for more information.
 - 2: This bit or register is not available on 64-pin devices.
 - 3: This bit or register is not available on devices without a CAN module.
 - 4: This bit or register is not available on 100-pin devices.
 - 5: Bits 31 and 30 are not available on 64-pin and 100-pin devices; bits 29 through 14 are not available on 64-pin devices.
 - 6: Bits 31, 30, 29, and bits 5 through 0 are not available on 64-pin and 100-pin devices; bit 31 is not available on 124-pin devices; bit 22 is not available on 64-pin devices.
 - 7: This bit or register is not available on devices without a Crypto module.
 - 8: This bit or register is not available on 124-pin devices.

TABLE 7-3: INTERRUPT REGISTER MAP (CONTINUED)

| Virtual Address (BF81_#) | Register Name ⁽¹⁾ | Bit Range | Bits | | | | | | | | | | | | | | | All Resets | |
|-----------------------------|---------------------------------|--------------|------------|-------|-------|-------|-------|-------|------|------|------|------|------|------|------|------|------|---------------|------|
| | | | 31/15 | 30/14 | 29/13 | 28/12 | 27/11 | 26/10 | 25/9 | 24/8 | 23/7 | 22/6 | 21/5 | 20/4 | 19/3 | 18/2 | 17/1 | | 16/0 |
| 07E0 | OFF168 | 31:16 | — | — | — | — | — | — | — | — | — | — | — | — | — | — | — | VOFF<17:16> | 0000 |
| | | 15:0 | VOFF<15:1> | | | | | | | | | | | | | | | — | 0000 |
| 07E4 | OFF169 | 31:16 | — | — | — | — | — | — | — | — | — | — | — | — | — | — | — | VOFF<17:16> | 0000 |
| | | 15:0 | VOFF<15:1> | | | | | | | | | | | | | | | — | 0000 |
| 07E8 | OFF170 | 31:16 | — | — | — | — | — | — | — | — | — | — | — | — | — | — | — | VOFF<17:16> | 0000 |
| | | 15:0 | VOFF<15:1> | | | | | | | | | | | | | | | — | 0000 |
| 07EC | OFF171 | 31:16 | — | — | — | — | — | — | — | — | — | — | — | — | — | — | — | VOFF<17:16> | 0000 |
| | | 15:0 | VOFF<15:1> | | | | | | | | | | | | | | | — | 0000 |
| 07F0 | OFF172 | 31:16 | — | — | — | — | — | — | — | — | — | — | — | — | — | — | — | VOFF<17:16> | 0000 |
| | | 15:0 | VOFF<15:1> | | | | | | | | | | | | | | | — | 0000 |
| 07F4 | OFF173 | 31:16 | — | — | — | — | — | — | — | — | — | — | — | — | — | — | — | VOFF<17:16> | 0000 |
| | | 15:0 | VOFF<15:1> | | | | | | | | | | | | | | | — | 0000 |
| 07F8 | OFF174 | 31:16 | — | — | — | — | — | — | — | — | — | — | — | — | — | — | — | VOFF<17:16> | 0000 |
| | | 15:0 | VOFF<15:1> | | | | | | | | | | | | | | | — | 0000 |
| 07FC | OFF175 | 31:16 | — | — | — | — | — | — | — | — | — | — | — | — | — | — | — | VOFF<17:16> | 0000 |
| | | 15:0 | VOFF<15:1> | | | | | | | | | | | | | | | — | 0000 |
| 0800 | OFF176 ⁽²⁾ | 31:16 | — | — | — | — | — | — | — | — | — | — | — | — | — | — | — | VOFF<17:16> | 0000 |
| | | 15:0 | VOFF<15:1> | | | | | | | | | | | | | | | — | 0000 |
| 0804 | OFF177 ⁽²⁾ | 31:16 | — | — | — | — | — | — | — | — | — | — | — | — | — | — | — | VOFF<17:16> | 0000 |
| | | 15:0 | VOFF<15:1> | | | | | | | | | | | | | | | — | 0000 |
| 0808 | OFF178 ⁽²⁾ | 31:16 | — | — | — | — | — | — | — | — | — | — | — | — | — | — | — | VOFF<17:16> | 0000 |
| | | 15:0 | VOFF<15:1> | | | | | | | | | | | | | | | — | 0000 |
| 080C | OFF179 | 31:16 | — | — | — | — | — | — | — | — | — | — | — | — | — | — | — | VOFF<17:16> | 0000 |
| | | 15:0 | VOFF<15:1> | | | | | | | | | | | | | | | — | 0000 |
| 0810 | OFF180 | 31:16 | — | — | — | — | — | — | — | — | — | — | — | — | — | — | — | VOFF<17:16> | 0000 |
| | | 15:0 | VOFF<15:1> | | | | | | | | | | | | | | | — | 0000 |
| 0814 | OFF181 | 31:16 | — | — | — | — | — | — | — | — | — | — | — | — | — | — | — | VOFF<17:16> | 0000 |
| | | 15:0 | VOFF<15:1> | | | | | | | | | | | | | | | — | 0000 |
| 0818 | OFF182 | 31:16 | — | — | — | — | — | — | — | — | — | — | — | — | — | — | — | VOFF<17:16> | 0000 |
| | | 15:0 | VOFF<15:1> | | | | | | | | | | | | | | | — | 0000 |

Legend: x = unknown value on Reset; — = unimplemented, read as '0'. Reset values are shown in hexadecimal.

- Note** 1: All registers in this table with the exception of the OFFx registers, have corresponding CLR, SET, and INV registers at their virtual addresses, plus offsets of 0x4, 0x8 and 0xC, respectively. See [Section 12.3 “CLR, SET, and INV Registers”](#) for more information.
- 2: This bit or register is not available on 64-pin devices.
- 3: This bit or register is not available on devices without a CAN module.
- 4: This bit or register is not available on 100-pin devices.
- 5: Bits 31 and 30 are not available on 64-pin and 100-pin devices; bits 29 through 14 are not available on 64-pin devices.
- 6: Bits 31, 30, 29, and bits 5 through 0 are not available on 64-pin and 100-pin devices; bit 31 is not available on 124-pin devices; bit 22 is not available on 64-pin devices.
- 7: This bit or register is not available on devices without a Crypto module.
- 8: This bit or register is not available on 124-pin devices.

TABLE 7-3: INTERRUPT REGISTER MAP (CONTINUED)

| Virtual Address (BF81_#) | Register Name ⁽¹⁾ | Bit Range | Bits | | | | | | | | | | | | | | All Resets | |
|-----------------------------|---------------------------------|-----------|------------|-------|-------|-------|-------|-------|------|------|------|------|------|------|------|------|-------------|------|
| | | | 31/15 | 30/14 | 29/13 | 28/12 | 27/11 | 26/10 | 25/9 | 24/8 | 23/7 | 22/6 | 21/5 | 20/4 | 19/3 | 18/2 | | 17/1 |
| 081C | OFF183 | 31:16 | — | — | — | — | — | — | — | — | — | — | — | — | — | — | VOFF<17:16> | 0000 |
| | | 15:0 | VOFF<15:1> | | | | | | | | | | | | | | — | 0000 |
| 0820 | OFF184 | 31:16 | — | — | — | — | — | — | — | — | — | — | — | — | — | — | VOFF<17:16> | 0000 |
| | | 15:0 | VOFF<15:1> | | | | | | | | | | | | | | — | 0000 |
| 0824 | OFF185 ⁽²⁾ | 31:16 | — | — | — | — | — | — | — | — | — | — | — | — | — | — | VOFF<17:16> | 0000 |
| | | 15:0 | VOFF<15:1> | | | | | | | | | | | | | | — | 0000 |
| 0828 | OFF186 ⁽²⁾ | 31:16 | — | — | — | — | — | — | — | — | — | — | — | — | — | — | VOFF<17:16> | 0000 |
| | | 15:0 | VOFF<15:1> | | | | | | | | | | | | | | — | 0000 |
| 082C | OFF187 ⁽²⁾ | 31:16 | — | — | — | — | — | — | — | — | — | — | — | — | — | — | VOFF<17:16> | 0000 |
| | | 15:0 | VOFF<15:1> | | | | | | | | | | | | | | — | 0000 |
| 0830 | OFF188 | 31:16 | — | — | — | — | — | — | — | — | — | — | — | — | — | — | VOFF<17:16> | 0000 |
| | | 15:0 | VOFF<15:1> | | | | | | | | | | | | | | — | 0000 |
| 0834 | OFF189 | 31:16 | — | — | — | — | — | — | — | — | — | — | — | — | — | — | VOFF<17:16> | 0000 |
| | | 15:0 | VOFF<15:1> | | | | | | | | | | | | | | — | 0000 |
| 0838 | OFF190 | 31:16 | — | — | — | — | — | — | — | — | — | — | — | — | — | — | VOFF<17:16> | 0000 |
| | | 15:0 | VOFF<15:1> | | | | | | | | | | | | | | — | 0000 |
| 0840 | OFF192 | 31:16 | — | — | — | — | — | — | — | — | — | — | — | — | — | — | VOFF<17:16> | 0000 |
| | | 15:0 | VOFF<15:1> | | | | | | | | | | | | | | — | 0000 |
| 0844 | OFF193 | 31:16 | — | — | — | — | — | — | — | — | — | — | — | — | — | — | VOFF<17:16> | 0000 |
| | | 15:0 | VOFF<15:1> | | | | | | | | | | | | | | — | 0000 |
| 0848 | OFF194 | 31:16 | — | — | — | — | — | — | — | — | — | — | — | — | — | — | VOFF<17:16> | 0000 |
| | | 15:0 | VOFF<15:1> | | | | | | | | | | | | | | — | 0000 |
| 0850 | OFF196 | 31:16 | — | — | — | — | — | — | — | — | — | — | — | — | — | — | VOFF<17:16> | 0000 |
| | | 15:0 | VOFF<15:1> | | | | | | | | | | | | | | — | 0000 |
| 0858 | OFF198 | 31:16 | — | — | — | — | — | — | — | — | — | — | — | — | — | — | VOFF<17:16> | 0000 |
| | | 15:0 | VOFF<15:1> | | | | | | | | | | | | | | — | 0000 |
| 085C | OFF199 | 31:16 | — | — | — | — | — | — | — | — | — | — | — | — | — | — | VOFF<17:16> | 0000 |
| | | 15:0 | VOFF<15:1> | | | | | | | | | | | | | | — | 0000 |
| 0860 | OFF200 | 31:16 | — | — | — | — | — | — | — | — | — | — | — | — | — | — | VOFF<17:16> | 0000 |
| | | 15:0 | VOFF<15:1> | | | | | | | | | | | | | | — | 0000 |

Legend: x = unknown value on Reset; — = unimplemented, read as '0'. Reset values are shown in hexadecimal.

- Note**
- 1: All registers in this table with the exception of the OFFx registers, have corresponding CLR, SET, and INV registers at their virtual addresses, plus offsets of 0x4, 0x8 and 0xC, respectively. See [Section 12.3 “CLR, SET, and INV Registers”](#) for more information.
 - 2: This bit or register is not available on 64-pin devices.
 - 3: This bit or register is not available on devices without a CAN module.
 - 4: This bit or register is not available on 100-pin devices.
 - 5: Bits 31 and 30 are not available on 64-pin and 100-pin devices; bits 29 through 14 are not available on 64-pin devices.
 - 6: Bits 31, 30, 29, and bits 5 through 0 are not available on 64-pin and 100-pin devices; bit 31 is not available on 124-pin devices; bit 22 is not available on 64-pin devices.
 - 7: This bit or register is not available on devices without a Crypto module.
 - 8: This bit or register is not available on 124-pin devices.

TABLE 7-3: INTERRUPT REGISTER MAP (CONTINUED)

| Virtual Address (BF81_#) | Register Name ⁽¹⁾ | Bit Range | Bits | | | | | | | | | | | | | | | All Resets | |
|-----------------------------|---------------------------------|-----------|------------|-------|-------|-------|-------|-------|------|------|------|------|------|------|------|------|------|-------------|------|
| | | | 31/15 | 30/14 | 29/13 | 28/12 | 27/11 | 26/10 | 25/9 | 24/8 | 23/7 | 22/6 | 21/5 | 20/4 | 19/3 | 18/2 | 17/1 | | 16/0 |
| 0864 | OFF201 | 31:16 | — | — | — | — | — | — | — | — | — | — | — | — | — | — | — | VOFF<17:16> | 0000 |
| | | 15:0 | VOFF<15:1> | | | | | | | | | | | | | | | — | 0000 |
| 0868 | OFF202 | 31:16 | — | — | — | — | — | — | — | — | — | — | — | — | — | — | — | VOFF<17:16> | 0000 |
| | | 15:0 | VOFF<15:1> | | | | | | | | | | | | | | | — | 0000 |
| 0874 | OFF205 | 31:16 | — | — | — | — | — | — | — | — | — | — | — | — | — | — | — | VOFF<17:16> | 0000 |
| | | 15:0 | VOFF<15:1> | | | | | | | | | | | | | | | — | 0000 |
| 0878 | OFF206 | 31:16 | — | — | — | — | — | — | — | — | — | — | — | — | — | — | — | VOFF<17:16> | 0000 |
| | | 15:0 | VOFF<15:1> | | | | | | | | | | | | | | | — | 0000 |
| 087C | OFF207 | 31:16 | — | — | — | — | — | — | — | — | — | — | — | — | — | — | — | VOFF<17:16> | 0000 |
| | | 15:0 | VOFF<15:1> | | | | | | | | | | | | | | | — | 0000 |
| 0880 | OFF208 | 31:16 | — | — | — | — | — | — | — | — | — | — | — | — | — | — | — | VOFF<17:16> | 0000 |
| | | 15:0 | VOFF<15:1> | | | | | | | | | | | | | | | — | 0000 |
| 0884 | OFF209 | 31:16 | — | — | — | — | — | — | — | — | — | — | — | — | — | — | — | VOFF<17:16> | 0000 |
| | | 15:0 | VOFF<15:1> | | | | | | | | | | | | | | | — | 0000 |
| 0888 | OFF210 | 31:16 | — | — | — | — | — | — | — | — | — | — | — | — | — | — | — | VOFF<17:16> | 0000 |
| | | 15:0 | VOFF<15:1> | | | | | | | | | | | | | | | — | 0000 |
| 0894 | OFF213 | 31:16 | — | — | — | — | — | — | — | — | — | — | — | — | — | — | — | VOFF<17:16> | 0000 |
| | | 15:0 | VOFF<15:1> | | | | | | | | | | | | | | | — | 0000 |

Legend: x = unknown value on Reset; — = unimplemented, read as '0'. Reset values are shown in hexadecimal.

- Note**
- 1: All registers in this table with the exception of the OFFx registers, have corresponding CLR, SET, and INV registers at their virtual addresses, plus offsets of 0x4, 0x8 and 0xC, respectively. See [Section 12.3 "CLR, SET, and INV Registers"](#) for more information.
 - 2: This bit or register is not available on 64-pin devices.
 - 3: This bit or register is not available on devices without a CAN module.
 - 4: This bit or register is not available on 100-pin devices.
 - 5: Bits 31 and 30 are not available on 64-pin and 100-pin devices; bits 29 through 14 are not available on 64-pin devices.
 - 6: Bits 31, 30, 29, and bits 5 through 0 are not available on 64-pin and 100-pin devices; bit 31 is not available on 124-pin devices; bit 22 is not available on 64-pin devices.
 - 7: This bit or register is not available on devices without a Crypto module.
 - 8: This bit or register is not available on 124-pin devices.

PIC32MZ Embedded Connectivity with Floating Point Unit (EF) Family

REGISTER 7-1: INTCON: INTERRUPT CONTROL REGISTER

| Bit Range | Bit 31/23/15/7 | Bit 30/22/14/6 | Bit 29/21/13/5 | Bit 28/20/12/4 | Bit 27/19/11/3 | Bit 26/18/10/2 | Bit 25/17/9/1 | Bit 24/16/8/0 |
|-----------|----------------|----------------|----------------|----------------|----------------|----------------|---------------|---------------|
| 31:24 | R/W-0 | R/W-0 | R/W-0 | R/W-0 | R/W-0 | R/W-0 | R/W-0 | R/W-0 |
| | NMIKEY<7:0> | | | | | | | |
| 23:16 | U-0 | U-0 | U-0 | U-0 | U-0 | U-0 | U-0 | U-0 |
| | — | — | — | — | — | — | — | — |
| 15:8 | U-0 | U-0 | U-0 | R/W-0 | U-0 | R/W-0 | R/W-0 | R/W-0 |
| | — | — | — | MVEC | — | TPC<2:0> | | |
| 7:0 | U-0 | U-0 | U-0 | R/W-0 | R/W-0 | R/W-0 | R/W-0 | R/W-0 |
| | — | — | — | INT4EP | INT3EP | INT2EP | INT1EP | INT0EP |

Legend:

R = Readable bit
-n = Value at POR

W = Writable bit
'1' = Bit is set

U = Unimplemented bit, read as '0'
'0' = Bit is cleared
x = Bit is unknown

- bit 31-24 **NMIKEY<7:0>**: Non-Maskable Interrupt Key bits
When the correct key (0x4E) is written, a software NMI will be generated. The status is indicated by the GNMI bit (RNMICON<19>).
- bit 23-13 **Unimplemented**: Read as '0'
- bit 12 **MVEC**: Multi Vector Configuration bit
1 = Interrupt controller configured for multi vectored mode
0 = Interrupt controller configured for single vectored mode
- bit 11 **Unimplemented**: Read as '0'
- bit 10-8 **TPC<2:0>**: Interrupt Proximity Timer Control bits
111 = Interrupts of group priority 7 or lower start the Interrupt Proximity timer
110 = Interrupts of group priority 6 or lower start the Interrupt Proximity timer
101 = Interrupts of group priority 5 or lower start the Interrupt Proximity timer
100 = Interrupts of group priority 4 or lower start the Interrupt Proximity timer
011 = Interrupts of group priority 3 or lower start the Interrupt Proximity timer
010 = Interrupts of group priority 2 or lower start the Interrupt Proximity timer
001 = Interrupts of group priority 1 start the Interrupt Proximity timer
000 = Disables Interrupt Proximity timer
- bit 7-5 **Unimplemented**: Read as '0'
- bit 4 **INT4EP**: External Interrupt 4 Edge Polarity Control bit
1 = Rising edge
0 = Falling edge
- bit 3 **INT3EP**: External Interrupt 3 Edge Polarity Control bit
1 = Rising edge
0 = Falling edge
- bit 2 **INT2EP**: External Interrupt 2 Edge Polarity Control bit
1 = Rising edge
0 = Falling edge
- bit 1 **INT1EP**: External Interrupt 1 Edge Polarity Control bit
1 = Rising edge
0 = Falling edge
- bit 0 **INT0EP**: External Interrupt 0 Edge Polarity Control bit
1 = Rising edge
0 = Falling edge

PIC32MZ Embedded Connectivity with Floating Point Unit (EF) Family

REGISTER 7-2: PRISS: PRIORITY SHADOW SELECT REGISTER

| Bit Range | Bit 31/23/15/7 | Bit 30/22/14/6 | Bit 29/21/13/5 | Bit 28/20/12/4 | Bit 27/19/11/3 | Bit 26/18/10/2 | Bit 25/17/9/1 | Bit 24/16/8/0 |
|-----------|----------------------------|----------------|----------------|----------------|----------------------------|----------------|---------------|---------------|
| 31:24 | R/W-0 | R/W-0 | R/W-0 | R/W-0 | R/W-0 | R/W-0 | R/W-0 | R/W-0 |
| | PRI7SS<3:0> ⁽¹⁾ | | | | PRI6SS<3:0> ⁽¹⁾ | | | |
| 23:16 | R/W-0 | R/W-0 | R/W-0 | R/W-0 | R/W-0 | R/W-0 | R/W-0 | R/W-0 |
| | PRI5SS<3:0> ⁽¹⁾ | | | | PRI4SS<3:0> ⁽¹⁾ | | | |
| 15:8 | R/W-0 | R/W-0 | R/W-0 | R/W-0 | R/W-0 | R/W-0 | R/W-0 | R/W-0 |
| | PRI3SS<3:0> | | | | PRI2SS<3:0> ⁽¹⁾ | | | |
| 7:0 | R/W-0 | R/W-0 | R/W-0 | R/W-0 | U-0 | U-0 | U-0 | R/W-0 |
| | PRI1SS<3:0> ⁽¹⁾ | | | | — | — | — | SS0 |

Legend:

| | | |
|-------------------|------------------|------------------------------------|
| R = Readable bit | W = Writable bit | U = Unimplemented bit, read as '0' |
| -n = Value at POR | '1' = Bit is set | '0' = Bit is cleared |
| | | x = Bit is unknown |

bit 31-28 **PRI7SS<3:0>**: Interrupt with Priority Level 7 Shadow Set bits⁽¹⁾

1xxx = Reserved (by default, an interrupt with a priority level of 7 uses Shadow Set 0)
 0111 = Interrupt with a priority level of 7 uses Shadow Set 7
 0110 = Interrupt with a priority level of 7 uses Shadow Set 6
 .
 .
 0001 = Interrupt with a priority level of 7 uses Shadow Set 1
 0000 = Interrupt with a priority level of 7 uses Shadow Set 0

bit 27-24 **PRI6SS<3:0>**: Interrupt with Priority Level 6 Shadow Set bits⁽¹⁾

1xxx = Reserved (by default, an interrupt with a priority level of 6 uses Shadow Set 0)
 0111 = Interrupt with a priority level of 6 uses Shadow Set 7
 0110 = Interrupt with a priority level of 6 uses Shadow Set 6
 .
 .
 0001 = Interrupt with a priority level of 6 uses Shadow Set 1
 0000 = Interrupt with a priority level of 6 uses Shadow Set 0

bit 23-20 **PRI5SS<3:0>**: Interrupt with Priority Level 5 Shadow Set bits⁽¹⁾

1xxx = Reserved (by default, an interrupt with a priority level of 5 uses Shadow Set 0)
 0111 = Interrupt with a priority level of 5 uses Shadow Set 7
 0110 = Interrupt with a priority level of 5 uses Shadow Set 6
 .
 .
 0001 = Interrupt with a priority level of 5 uses Shadow Set 1
 0000 = Interrupt with a priority level of 5 uses Shadow Set 0

bit 19-16 **PRI4SS<3:0>**: Interrupt with Priority Level 4 Shadow Set bits⁽¹⁾

1xxx = Reserved (by default, an interrupt with a priority level of 4 uses Shadow Set 0)
 0111 = Interrupt with a priority level of 4 uses Shadow Set 7
 0110 = Interrupt with a priority level of 4 uses Shadow Set 6
 .
 .
 0001 = Interrupt with a priority level of 4 uses Shadow Set 1
 0000 = Interrupt with a priority level of 4 uses Shadow Set 0

Note 1: These bits are ignored if the MVEC bit (INTCON<12>) = 0.

PIC32MZ Embedded Connectivity with Floating Point Unit (EF) Family

REGISTER 7-2: PRIS: PRIORITY SHADOW SELECT REGISTER (CONTINUED)

- bit 15-12 **PRI3SS<3:0>**: Interrupt with Priority Level 3 Shadow Set bits⁽¹⁾
- 1xxx = Reserved (by default, an interrupt with a priority level of 3 uses Shadow Set 0)
 - 0111 = Interrupt with a priority level of 3 uses Shadow Set 7
 - 0110 = Interrupt with a priority level of 3 uses Shadow Set 6
 -
 -
 -
 - 0001 = Interrupt with a priority level of 3 uses Shadow Set 1
 - 0000 = Interrupt with a priority level of 3 uses Shadow Set 0
- bit 11-8 **PRI2SS<3:0>**: Interrupt with Priority Level 2 Shadow Set bits⁽¹⁾
- 1xxx = Reserved (by default, an interrupt with a priority level of 2 uses Shadow Set 0)
 - 0111 = Interrupt with a priority level of 2 uses Shadow Set 7
 - 0110 = Interrupt with a priority level of 2 uses Shadow Set 6
 -
 -
 -
 - 0001 = Interrupt with a priority level of 2 uses Shadow Set 1
 - 0000 = Interrupt with a priority level of 2 uses Shadow Set 0
- bit 7-4 **PRI1SS<3:0>**: Interrupt with Priority Level 1 Shadow Set bits⁽¹⁾
- 1xxx = Reserved (by default, an interrupt with a priority level of 1 uses Shadow Set 0)
 - 0111 = Interrupt with a priority level of 1 uses Shadow Set 7
 - 0110 = Interrupt with a priority level of 1 uses Shadow Set 6
 -
 -
 -
 - 0001 = Interrupt with a priority level of 1 uses Shadow Set 1
 - 0000 = Interrupt with a priority level of 1 uses Shadow Set 0
- bit 3-1 **Unimplemented**: Read as '0'
- bit 0 **SS0**: Single Vector Shadow Register Set bit
- 1 = Single vector is presented with a shadow set
 - 0 = Single vector is not presented with a shadow set

Note 1: These bits are ignored if the MVEC bit (INTCON<12>) = 0.

PIC32MZ Embedded Connectivity with Floating Point Unit (EF) Family

REGISTER 7-3: INTSTAT: INTERRUPT STATUS REGISTER

| Bit Range | Bit 31/23/15/7 | Bit 30/22/14/6 | Bit 29/21/13/5 | Bit 28/20/12/4 | Bit 27/19/11/3 | Bit 26/18/10/2 | Bit 25/17/9/1 | Bit 24/16/8/0 |
|-----------|----------------|----------------|----------------|----------------|----------------|---------------------------|---------------|---------------|
| 31:24 | U-0 | U-0 | U-0 | U-0 | U-0 | U-0 | U-0 | U-0 |
| | — | — | — | — | — | — | — | — |
| 23:16 | U-0 | U-0 | U-0 | U-0 | U-0 | U-0 | U-0 | U-0 |
| | — | — | — | — | — | — | — | — |
| 15:8 | U-0 | U-0 | U-0 | U-0 | U-0 | R-0 | R-0 | R-0 |
| | — | — | — | — | — | SRIPL<2:0> ⁽¹⁾ | | |
| 7:0 | R-0 | R-0 | R-0 | R-0 | R-0 | R-0 | R-0 | R-0 |
| | SIRQ<7:0> | | | | | | | |

Legend:

R = Readable bit W = Writable bit U = Unimplemented bit, read as '0'
-n = Value at POR '1' = Bit is set '0' = Bit is cleared x = Bit is unknown

bit 31-11 **Unimplemented:** Read as '0'

bit 10-8 **SRIPL<2:0>:** Requested Priority Level bits for Single Vector Mode bits⁽¹⁾

111-000 = The priority level of the latest interrupt presented to the CPU

bit 7-6 **Unimplemented:** Read as '0'

bit 7-0 **SIRQ<7:0>:** Last Interrupt Request Serviced Status bits

11111111-00000000 = The last interrupt request number serviced by the CPU

Note 1: This value should only be used when the interrupt controller is configured for Single Vector mode.

REGISTER 7-4: IPTMR: INTERRUPT PROXIMITY TIMER REGISTER

| Bit Range | Bit 31/23/15/7 | Bit 30/22/14/6 | Bit 29/21/13/5 | Bit 28/20/12/4 | Bit 27/19/11/3 | Bit 26/18/10/2 | Bit 25/17/9/1 | Bit 24/16/8/0 |
|-----------|----------------|----------------|----------------|----------------|----------------|----------------|---------------|---------------|
| 31:24 | R/W-0 | R/W-0 | R/W-0 | R/W-0 | R/W-0 | R/W-0 | R/W-0 | R/W-0 |
| | IPTMR<31:24> | | | | | | | |
| 23:16 | R/W-0 | R/W-0 | R/W-0 | R/W-0 | R/W-0 | R/W-0 | R/W-0 | R/W-0 |
| | IPTMR<23:16> | | | | | | | |
| 15:8 | R/W-0 | R/W-0 | R/W-0 | R/W-0 | R/W-0 | R/W-0 | R/W-0 | R/W-0 |
| | IPTMR<15:8> | | | | | | | |
| 7:0 | R/W-0 | R/W-0 | R/W-0 | R/W-0 | R/W-0 | R/W-0 | R/W-0 | R/W-0 |
| | IPTMR<7:0> | | | | | | | |

Legend:

R = Readable bit W = Writable bit U = Unimplemented bit, read as '0'
-n = Value at POR '1' = Bit is set '0' = Bit is cleared x = Bit is unknown

bit 31-0 **IPTMR<31:0>:** Interrupt Proximity Timer Reload bits

Used by the Interrupt Proximity Timer as a reload value when the Interrupt Proximity timer is triggered by an interrupt event.

PIC32MZ Embedded Connectivity with Floating Point Unit (EF) Family

REGISTER 7-5: IFSx: INTERRUPT FLAG STATUS REGISTER

| Bit Range | Bit 31/23/15/7 | Bit 30/22/14/6 | Bit 29/21/13/5 | Bit 28/20/12/4 | Bit 27/19/11/3 | Bit 26/18/10/2 | Bit 25/17/9/1 | Bit 24/16/8/0 |
|-----------|----------------|----------------|----------------|----------------|----------------|----------------|---------------|---------------|
| 31:24 | R/W-0 | R/W-0 | R/W-0 | R/W-0 | R/W-0 | R/W-0 | R/W-0 | R/W-0 |
| | IFS31 | IFS30 | IFS29 | IFS28 | IFS27 | IFS26 | IFS25 | IFS24 |
| 23:16 | R/W-0 | R/W-0 | R/W-0 | R/W-0 | R/W-0 | R/W-0 | R/W-0 | R/W-0 |
| | IFS23 | IFS22 | IFS21 | IFS20 | IFS19 | IFS18 | IFS17 | IFS16 |
| 15:8 | R/W-0 | R/W-0 | R/W-0 | R/W-0 | R/W-0 | R/W-0 | R/W-0 | R/W-0 |
| | IFS15 | IFS14 | IFS13 | IFS12 | IFS11 | IFS10 | IFS9 | IFS8 |
| 7:0 | R/W-0 | R/W-0 | R/W-0 | R/W-0 | R/W-0 | R/W-0 | R/W-0 | R/W-0 |
| | IFS7 | IFS6 | IFS5 | IFS4 | IFS3 | IFS2 | IFS1 | IFS0 |

Legend:

R = Readable bit
-n = Value at POR

W = Writable bit
'1' = Bit is set

U = Unimplemented bit, read as '0'
'0' = Bit is cleared
x = Bit is unknown

bit 31-0 **IFS31-IFS0**: Interrupt Flag Status bits
1 = Interrupt request has occurred
0 = No interrupt request has occurred

Note: This register represents a generic definition of the IFSx register. Refer to [Table 7-2](#) for the exact bit definitions.

REGISTER 7-6: IECx: INTERRUPT ENABLE CONTROL REGISTER

| Bit Range | Bit 31/23/15/7 | Bit 30/22/14/6 | Bit 29/21/13/5 | Bit 28/20/12/4 | Bit 27/19/11/3 | Bit 26/18/10/2 | Bit 25/17/9/1 | Bit 24/16/8/0 |
|-----------|----------------|----------------|----------------|----------------|----------------|----------------|---------------|---------------|
| 31:24 | R/W-0 | R/W-0 | R/W-0 | R/W-0 | R/W-0 | R/W-0 | R/W-0 | R/W-0 |
| | IEC31 | IEC30 | IEC29 | IEC28 | IEC27 | IEC26 | IEC25 | IEC24 |
| 23:16 | R/W-0 | R/W-0 | R/W-0 | R/W-0 | R/W-0 | R/W-0 | R/W-0 | R/W-0 |
| | IEC23 | IEC22 | IEC21 | IEC20 | IEC19 | IEC18 | IEC17 | IEC16 |
| 15:8 | R/W-0 | R/W-0 | R/W-0 | R/W-0 | R/W-0 | R/W-0 | R/W-0 | R/W-0 |
| | IEC15 | IEC14 | IEC13 | IEC12 | IEC11 | IEC10 | IEC9 | IEC8 |
| 7:0 | R/W-0 | R/W-0 | R/W-0 | R/W-0 | R/W-0 | R/W-0 | R/W-0 | R/W-0 |
| | IEC7 | IEC6 | IEC5 | IEC4 | IEC3 | IEC2 | IEC1 | IEC0 |

Legend:

R = Readable bit
-n = Value at POR

W = Writable bit
'1' = Bit is set

U = Unimplemented bit, read as '0'
'0' = Bit is cleared
x = Bit is unknown

bit 31-0 **IEC31-IEC0**: Interrupt Enable bits
1 = Interrupt is enabled
0 = Interrupt is disabled

Note: This register represents a generic definition of the IECx register. Refer to [Table 7-2](#) for the exact bit definitions.

PIC32MZ Embedded Connectivity with Floating Point Unit (EF) Family

REGISTER 7-7: IPCx: INTERRUPT PRIORITY CONTROL REGISTER

| Bit Range | Bit 31/23/15/7 | Bit 30/22/14/6 | Bit 29/21/13/5 | Bit 28/20/12/4 | Bit 27/19/11/3 | Bit 26/18/10/2 | Bit 25/17/9/1 | Bit 24/16/8/0 |
|-----------|----------------|----------------|----------------|----------------|----------------|----------------|---------------|---------------|
| 31:24 | U-0 | U-0 | U-0 | R/W-0 | R/W-0 | R/W-0 | R/W-0 | R/W-0 |
| | — | — | — | IP3<2:0> | | | IS3<1:0> | |
| 23:16 | U-0 | U-0 | U-0 | R/W-0 | R/W-0 | R/W-0 | R/W-0 | R/W-0 |
| | — | — | — | IP2<2:0> | | | IS2<1:0> | |
| 15:8 | U-0 | U-0 | U-0 | R/W-0 | R/W-0 | R/W-0 | R/W-0 | R/W-0 |
| | — | — | — | IP1<2:0> | | | IS1<1:0> | |
| 7:0 | U-0 | U-0 | U-0 | R/W-0 | R/W-0 | R/W-0 | R/W-0 | R/W-0 |
| | — | — | — | IP0<2:0> | | | IS0<1:0> | |

Legend:

| | | |
|-------------------|------------------|------------------------------------|
| R = Readable bit | W = Writable bit | U = Unimplemented bit, read as '0' |
| -n = Value at POR | '1' = Bit is set | '0' = Bit is cleared |
| | | x = Bit is unknown |

bit 31-29 **Unimplemented:** Read as '0'

bit 28-26 **IP3<2:0>:** Interrupt Priority bits

111 = Interrupt priority is 7

•
•
•

010 = Interrupt priority is 2

001 = Interrupt priority is 1

000 = Interrupt is disabled

bit 25-24 **IS3<1:0>:** Interrupt Subpriority bits

11 = Interrupt subpriority is 3

10 = Interrupt subpriority is 2

01 = Interrupt subpriority is 1

00 = Interrupt subpriority is 0

bit 23-21 **Unimplemented:** Read as '0'

bit 20-18 **IP2<2:0>:** Interrupt Priority bits

111 = Interrupt priority is 7

•
•
•

010 = Interrupt priority is 2

001 = Interrupt priority is 1

000 = Interrupt is disabled

bit 17-16 **IS2<1:0>:** Interrupt Subpriority bits

11 = Interrupt subpriority is 3

10 = Interrupt subpriority is 2

01 = Interrupt subpriority is 1

00 = Interrupt subpriority is 0

bit 15-13 **Unimplemented:** Read as '0'

Note: This register represents a generic definition of the IPCx register. Refer to [Table 7-2](#) for the exact bit definitions.

PIC32MZ Embedded Connectivity with Floating Point Unit (EF) Family

REGISTER 7-7: IPCx: INTERRUPT PRIORITY CONTROL REGISTER (CONTINUED)

bit 12-10 **IP1<2:0>**: Interrupt Priority bits

111 = Interrupt priority is 7

•
•

010 = Interrupt priority is 2

001 = Interrupt priority is 1

000 = Interrupt is disabled

bit 9-8 **IS1<1:0>**: Interrupt Subpriority bits

11 = Interrupt subpriority is 3

10 = Interrupt subpriority is 2

01 = Interrupt subpriority is 1

00 = Interrupt subpriority is 0

bit 7-5 **Unimplemented**: Read as '0'

bit 4-2 **IP0<2:0>**: Interrupt Priority bits

111 = Interrupt priority is 7

•
•

010 = Interrupt priority is 2

001 = Interrupt priority is 1

000 = Interrupt is disabled

bit 1-0 **IS0<1:0>**: Interrupt Subpriority bits

11 = Interrupt subpriority is 3

10 = Interrupt subpriority is 2

01 = Interrupt subpriority is 1

00 = Interrupt subpriority is 0

| |
|--|
| Note: This register represents a generic definition of the IPCx register. Refer to Table 7-2 for the exact bit definitions. |
|--|

PIC32MZ Embedded Connectivity with Floating Point Unit (EF) Family

REGISTER 7-8: OFF_x: INTERRUPT VECTOR ADDRESS OFFSET REGISTER (x = 0-190)

| Bit Range | Bit 31/23/15/7 | Bit 30/22/14/6 | Bit 29/21/13/5 | Bit 28/20/12/4 | Bit 27/19/11/3 | Bit 26/18/10/2 | Bit 25/17/9/1 | Bit 24/16/8/0 |
|-----------|----------------|----------------|----------------|----------------|----------------|----------------|---------------|---------------|
| 31:24 | U-0 | U-0 | U-0 | U-0 | U-0 | U-0 | U-0 | U-0 |
| | — | — | — | — | — | — | — | — |
| 23:16 | U-0 | U-0 | U-0 | U-0 | U-0 | U-0 | R/W-0 | R/W-0 |
| | — | — | — | — | — | — | VOFF<17:16> | |
| 15:8 | R/W-0 | R/W-0 | R/W-0 | R/W-0 | R/W-0 | R/W-0 | R/W-0 | R/W-0 |
| | VOFF<15:8> | | | | | | | |
| 7:0 | R/W-0 | R/W-0 | R/W-0 | R/W-0 | R/W-0 | R/W-0 | R/W-0 | U-0 |
| | VOFF<7:1> | | | | | | | — |

Legend:

R = Readable bit

W = Writable bit

U = Unimplemented bit, read as '0'

-n = Value at POR

'1' = Bit is set

'0' = Bit is cleared

x = Bit is unknown

bit 31-16 **Unimplemented:** Read as '0'

bit 17-1 **VOFF<17:1>:** Interrupt Vector 'x' Address Offset bits

bit 0 **Unimplemented:** Read as '0'

PIC32MZ Embedded Connectivity with Floating Point Unit (EF) Family

NOTES:

8.0 OSCILLATOR CONFIGURATION

Note: This data sheet summarizes the features of the PIC32MZ EF family of devices. It is not intended to be a comprehensive reference source. To complement the information in this data sheet, refer to **Section 42. “Oscillators with Enhanced PLL”** (DS60001250) in the *“PIC32 Family Reference Manual”*, which is available from the Microchip web site (www.microchip.com/PIC32).

The PIC32MZ EF oscillator system has the following modules and features:

- A total of five external and internal oscillator options as clock sources
- On-Chip PLL with user-selectable input divider, multiplier and output divider to boost operating frequency on select internal and external oscillator sources
- On-Chip user-selectable divisor postscaler on select oscillator sources
- Software-controllable switching between various clock sources
- A Fail-Safe Clock Monitor (FSCM) that detects clock failure and permits safe application recovery or shutdown with dedicated Back-up FRC (BFRC)
- Dedicated On-Chip PLL for USB peripheral
- Flexible reference clock output
- Multiple clock branches for peripherals for better performance flexibility
- Clock switch/slew control with output divider

A block diagram of the oscillator system is provided in [Figure 8-1](#). The clock distribution is shown in [Table 8-1](#).

PIC32MZ Embedded Connectivity with Floating Point Unit (EF) Family

FIGURE 8-1: PIC32MZ EF FAMILY OSCILLATOR DIAGRAM

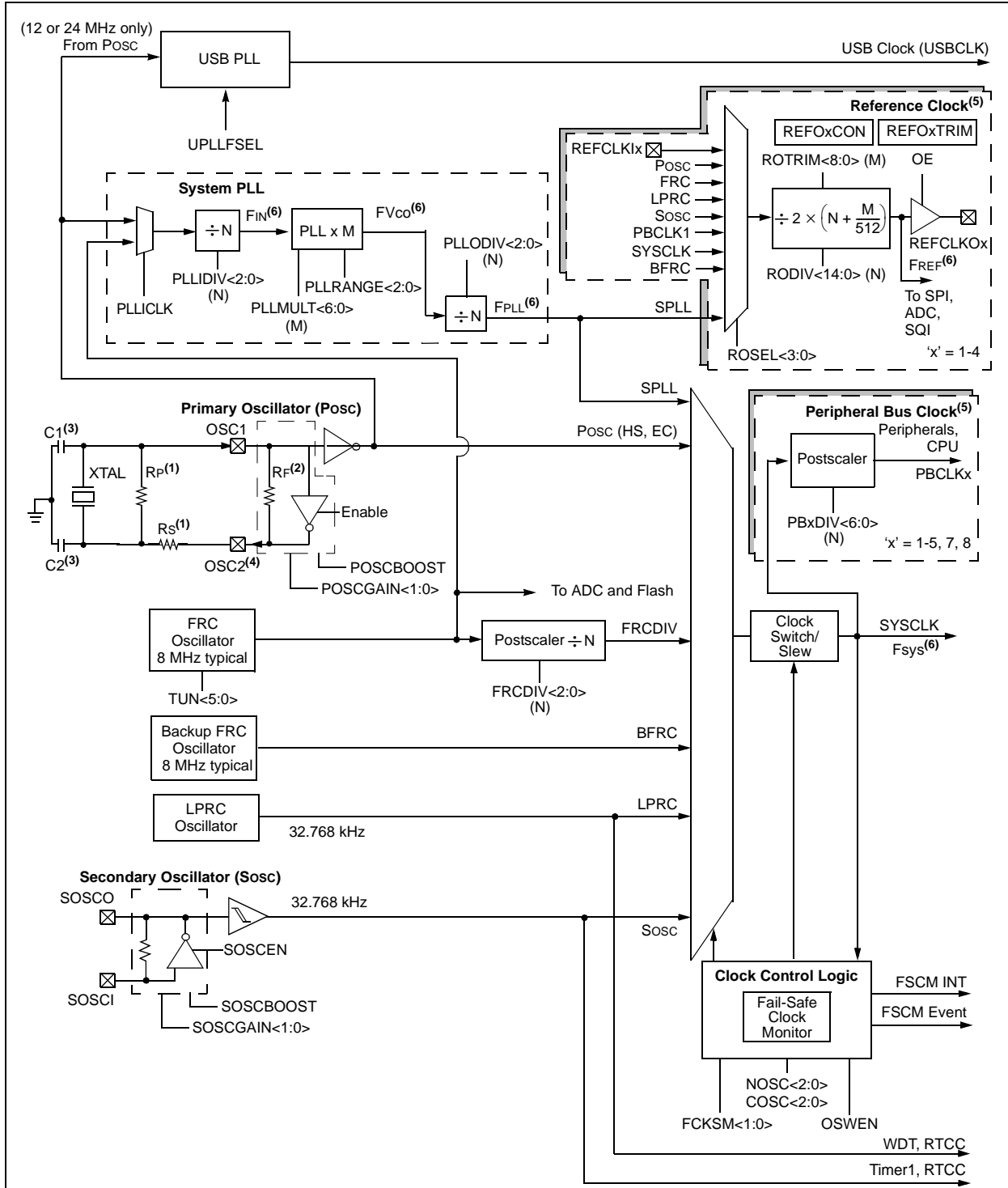

- Notes:**
1. A series resistor, Rs, may be required for AT strip cut crystals, or to eliminate clipping. Alternately, to increase oscillator circuit gain, add a parallel resistor, Rp.
 2. The internal feedback resistor, Rf, is typically in the range of 2 to 10 MΩ.
 3. Refer to **Section 42. "Oscillators with Enhanced PLL"** (DS60001250) in the "*PIC32 Family Reference Manual*" for help in determining the best oscillator components.
 4. PBCLK1 divided by 2 is available on the OSC2 pin in certain clock modes.
 5. Shaded regions indicate multiple instantiations of a peripheral or feature.
 6. Refer to **Table 37-19 in Section 37.0 "Electrical Characteristics"** for frequency limitations.

PIC32MZ Embedded Connectivity with Floating Point Unit (EF) Family

TABLE 8-1: SYSTEM AND PERIPHERAL CLOCK DISTRIBUTION

| Peripheral | Clock Source | | | | | | | | | | | | | | |
|-------------------|------------------|------|------------------|------------------|--------|-----------------------|--------|------------------|--------|------------------|--------|--------|----------|----------|----------|
| | FRC | LPRC | SOSC | SYCLK | USBCLK | PBCLK1 ⁽¹⁾ | PBCLK2 | PBCLK3 | PBCLK4 | PBCLK5 | PBCLK7 | PBCLK8 | REFCLK01 | REFCLK02 | REFCLK03 |
| CPU | | | | | | | | | | | X | | | | |
| WDT | | X | | | | X ⁽²⁾ | | | | | | | | | |
| Deadman Timer | | | | | | X ⁽²⁾ | | | | | X | | | | |
| Flash | X ⁽²⁾ | | | X ⁽²⁾ | | X ⁽²⁾ | | | | | | | | | |
| ADC | X | | | X | | | | X ⁽³⁾ | | | | | | | X |
| Comparator | | | | | | | | X | | | | | | | |
| Crypto | | | | | | | | | | X | | | | | |
| RNG | | | | | | | | | | X | | | | | |
| USB | | | | | X | | | | | X ⁽³⁾ | | | | | |
| CAN | | | | | | | | | | X | | | | | |
| Ethernet | | | | | | | | | | X ⁽³⁾ | | | | | |
| PMP | | | | | | | X | | | | | | | | |
| I ² C™ | | | | | | | X | | | | | | | | |
| UART | | | | | | | X | | | | | | | | |
| RTCC | | X | X | | | X ⁽²⁾ | | | | | | | | | |
| EBI | | | | | | | | | | | | X | | | |
| SQI | | | | | | | | | | X ⁽³⁾ | | | | X | |
| SPI | | | | | | | X | | | | | | X | | |
| Timers | | | X ⁽⁴⁾ | | | | | X | | | | | | | |
| Output Compare | | | | | | | | X | | | | | | | |
| Input Capture | | | | | | | | X | | | | | | | |
| Ports | | | | | | | | | X | | | | | | |
| DMA | | | | X | | | | | | | | | | | |
| Interrupts | | | | X | | | | | | | | | | | |
| Prefetch | | | | X | | | | | | | | | | | |
| OSC2 Pin | | | | | | X ⁽⁵⁾ | | | | | | | | | |

- Note 1:** PBCLK1 is used by system modules and cannot be turned off.
Note 2: SYCLK/PBCLK1 is used to fetch data from/to the Flash Controller, while the FRC clock is used for programming.
Note 3: Special Function Register (SFR) access only.
Note 4: Timer1 only.
Note 5: PBCLK1 divided by 2 is available on the OSC2 pin in certain clock modes.

8.1 Fail-Safe Clock Monitor (FSCM)

The PIC32MZ EF oscillator system includes a Fail-safe Clock Monitor (FSCM). The FSCM monitors the SYCLK for continuous operation. If it detects that the SYCLK has failed, it switches the SYCLK over to the BFRC oscillator and triggers a NMI. The BFRC is an untuned 8 MHz oscillator that will drive the SYCLK during FSCM event. When the NMI is executed, software can attempt to restart the main oscillator or shut down the system.

In Sleep mode both the SYCLK and the FSCM halt, which prevents FSCM detection.

8.2 Oscillator Control Registers

TABLE 8-2: OSCILLATOR CONFIGURATION REGISTER MAP

| Virtual Address (BF80_#) | Register Name ⁽¹⁾ | Bit Range | Bits | | | | | | | | | | | | | | All Resets ⁽²⁾ | | |
|-----------------------------|---------------------------------|-----------|-------------|-------------|-------|-------|----------|--------------|---------|--------|---------|--------------|------------|-------|------------|---------------|---------------------------|-------|------|
| | | | 31/15 | 30/14 | 29/13 | 28/12 | 27/11 | 26/10 | 25/9 | 24/8 | 23/7 | 22/6 | 21/5 | 20/4 | 19/3 | 18/2 | | 17/1 | 16/0 |
| 1200 | OSCCON | 31:16 | — | — | — | — | — | FRCDIV<2:0> | | | DRMEN | — | SLP2SPD | — | — | — | — | — | 0000 |
| | | 15:0 | — | COSC<2:0> | | | — | NOSC<2:0> | | | CLKLOCK | — | — | SLPEN | CF | — | SOSCEN | OSWEN | xx0x |
| 1210 | OSCTUN | 31:16 | — | — | — | — | — | — | — | — | — | — | — | — | — | — | — | — | 0000 |
| | | 15:0 | — | — | — | — | — | — | — | — | — | — | TUN<5:0> | | | | | 00xx | |
| 1220 | SPLLCON | 31:16 | — | — | — | — | — | PLLODIV<2:0> | | | — | PLLMULT<6:0> | | | | | | 01xx | |
| | | 15:0 | — | — | — | — | — | PLLIDIV<2:0> | | | PLLICK | — | — | — | — | PLLRANGE<2:0> | | | 0x0x |
| 1280 | REFO1CON | 31:16 | — | RODIV<14:0> | | | | | | | | | | | | | | 0000 | |
| | | 15:0 | ON | — | SIDL | OE | RSLP | — | DIVSWEN | ACTIVE | — | — | — | — | ROSEL<3:0> | | | 0000 | |
| 1290 | REFO1TRIM | 31:16 | ROTRIM<8:0> | | | | | | | | | | | | | | 0000 | | |
| | | 15:0 | — | — | — | — | — | — | — | — | — | — | — | — | — | — | — | — | 0000 |
| 12A0 | REFO2CON | 31:16 | — | RODIV<14:0> | | | | | | | | | | | | | | 0000 | |
| | | 15:0 | ON | — | SIDL | OE | RSLP | — | DIVSWEN | ACTIVE | — | — | — | — | ROSEL<3:0> | | | 0000 | |
| 12B0 | REFO2TRIM | 31:16 | ROTRIM<8:0> | | | | | | | | | | | | | | 0000 | | |
| | | 15:0 | — | — | — | — | — | — | — | — | — | — | — | — | — | — | — | — | 0000 |
| 12C0 | REFO3CON | 31:16 | — | RODIV<14:0> | | | | | | | | | | | | | | 0000 | |
| | | 15:0 | ON | — | SIDL | OE | RSLP | — | DIVSWEN | ACTIVE | — | — | — | — | ROSEL<3:0> | | | 0000 | |
| 12D0 | REFO3TRIM | 31:16 | ROTRIM<8:0> | | | | | | | | | | | | | | 0000 | | |
| | | 15:0 | — | — | — | — | — | — | — | — | — | — | — | — | — | — | — | — | 0000 |
| 12E0 | REFO4CON | 31:16 | — | RODIV<14:0> | | | | | | | | | | | | | | 0000 | |
| | | 15:0 | ON | — | SIDL | OE | RSLP | — | DIVSWEN | ACTIVE | — | — | — | — | ROSEL<3:0> | | | 0000 | |
| 12F0 | REFO4TRIM | 31:16 | ROTRIM<8:0> | | | | | | | | | | | | | | 0000 | | |
| | | 15:0 | — | — | — | — | — | — | — | — | — | — | — | — | — | — | — | — | 0000 |
| 1300 | PB1DIV | 31:16 | — | — | — | — | — | — | — | — | — | — | — | — | — | — | — | — | 0000 |
| | | 15:0 | — | — | — | — | PBDIVRDY | — | — | — | — | — | PBDIV<6:0> | | | | | 8801 | |
| 1310 | PB2DIV | 31:16 | — | — | — | — | — | — | — | — | — | — | — | — | — | — | — | — | 0000 |
| | | 15:0 | ON | — | — | — | PBDIVRDY | — | — | — | — | PBDIV<6:0> | | | | | 8801 | | |
| 1320 | PB3DIV | 31:16 | — | — | — | — | — | — | — | — | — | — | — | — | — | — | — | — | 0000 |
| | | 15:0 | ON | — | — | — | PBDIVRDY | — | — | — | — | PBDIV<6:0> | | | | | 8801 | | |
| 1330 | PB4DIV | 31:16 | — | — | — | — | — | — | — | — | — | — | — | — | — | — | — | — | 0000 |
| | | 15:0 | ON | — | — | — | PBDIVRDY | — | — | — | — | PBDIV<6:0> | | | | | 8801 | | |
| 1340 | PB5DIV | 31:16 | — | — | — | — | — | — | — | — | — | — | — | — | — | — | — | — | 0000 |
| | | 15:0 | ON | — | — | — | PBDIVRDY | — | — | — | — | PBDIV<6:0> | | | | | 8801 | | |

Legend: x = unknown value on Reset; — = unimplemented, read as '0'. Reset values are shown in hexadecimal.

- Note** 1: All registers in this table have corresponding CLR, SET, and INV registers at their virtual addresses, plus offsets of 0x4, 0x8 and 0xC, respectively. See [Section 12.3 "CLR, SET, and INV Registers"](#) for more information.
 2: Reset values are dependent on the DEVCFGx Configuration bits and the type of reset.

TABLE 8-2: OSCILLATOR CONFIGURATION REGISTER MAP (CONTINUED)

| Virtual Address (BF80_#) | Register Name ⁽¹⁾ | Bit Range | Bits | | | | | | | | | | | | | | | All Resets ⁽²⁾ | | |
|-----------------------------|---------------------------------|-----------|-------|-------|-------|-------|----------|-------------|------|------|------|------------|-------------|-------------|-------------|-------------|----------------|---------------------------|------|------|
| | | | 31/15 | 30/14 | 29/13 | 28/12 | 27/11 | 26/10 | 25/9 | 24/8 | 23/7 | 22/6 | 21/5 | 20/4 | 19/3 | 18/2 | 17/1 | | 16/0 | |
| 1360 | PB7DIV | 31:16 | — | — | — | — | — | — | — | — | — | — | — | — | — | — | — | — | 0000 | |
| | | 15:0 | ON | — | — | — | PBDIVRDY | — | — | — | — | PBDIV<6:0> | | | | | | — | — | — |
| 1370 | PB8DIV | 31:16 | — | — | — | — | — | — | — | — | — | — | — | — | — | — | — | — | 0000 | |
| | | 15:0 | ON | — | — | — | PBDIVRDY | — | — | — | — | PBDIV<6:0> | | | | | | — | — | — |
| 13C0 | SLEWCON | 31:16 | — | — | — | — | — | — | — | — | — | — | — | — | SYSDIV<3:0> | | | — | — | 0000 |
| | | 15:0 | — | — | — | — | — | SLWDIV<2:0> | | | | — | — | — | — | — | UPEN | DNEN | BUSY | 0204 |
| 13D0 | CLKSTAT | 31:16 | — | — | — | — | — | — | — | — | — | — | — | — | — | — | — | — | 0000 | |
| | | 15:0 | — | — | — | — | — | — | — | — | — | — | LPRC RDY | SOSC RDY | — | POSC RDY | SPLL DIVRDY | FRCRDY | 0000 | |

Legend: x = unknown value on Reset; — = unimplemented, read as '0'. Reset values are shown in hexadecimal.

Note 1: All registers in this table have corresponding CLR, SET, and INV registers at their virtual addresses, plus offsets of 0x4, 0x8 and 0xC, respectively. See [Section 12.3 “CLR, SET, and INV Registers”](#) for more information.
Note 2: Reset values are dependent on the DEVCFGx Configuration bits and the type of reset.

PIC32MZ Embedded Connectivity with Floating Point Unit (EF) Family

REGISTER 8-1: OSCCON: OSCILLATOR CONTROL REGISTER

| Bit Range | Bit 31/23/15/7 | Bit 30/22/14/6 | Bit 29/21/13/5 | Bit 28/20/12/4 | Bit 27/19/11/3 | Bit 26/18/10/2 | Bit 25/17/9/1 | Bit 24/16/8/0 |
|-----------|----------------|----------------|------------------------|----------------|----------------|----------------|---------------|----------------------|
| 31:24 | U-0 | U-0 | U-0 | U-0 | U-0 | R/W-0 | R/W-0 | R/W-0 |
| | — | — | — | — | — | FRCDIV<2:0> | | |
| 23:16 | R/W-0 | U-0 | R/W-y | U-0 | U-0 | U-0 | U-0 | U-0 |
| | DRMEN | — | SLP2SPD ⁽¹⁾ | — | — | — | — | — |
| 15:8 | U-0 | R-0 | R-0 | R-0 | U-0 | R/W-y | R/W-y | R/W-y |
| | — | COSC<2:0> | | | — | NOSC<2:0> | | |
| 7:0 | R/W-0 | U-0 | U-0 | R/W-0 | R/W-0, HS | U-0 | R/W-y | R/W-y |
| | CLKLOCK | — | — | SLPEN | CF | — | SOSCEN | OSWEN ⁽¹⁾ |

| | | |
|-------------------|--|------------------------------------|
| Legend: | y = Value set from Configuration bits on POR | HS = Hardware Set |
| R = Readable bit | W = Writable bit | U = Unimplemented bit, read as '0' |
| -n = Value at POR | '1' = Bit is set | '0' = Bit is cleared |
| | | x = Bit is unknown |

bit 31-27 **Unimplemented:** Read as '0'

bit 26-24 **FRCDIV<2:0>:** Internal Fast RC (FRC) Oscillator Clock Divider bits

- 111 = FRC divided by 256
- 110 = FRC divided by 64
- 101 = FRC divided by 32
- 100 = FRC divided by 16
- 011 = FRC divided by 8
- 010 = FRC divided by 4
- 001 = FRC divided by 2
- 000 = FRC divided by 1 (default setting)

bit 23 **DRMEN:** Dream Mode Enable bit

- 1 = Dream mode is enabled
- 0 = Dream mode is disabled

bit 22 **Unimplemented:** Read as '0'

bit 21 **SLP2SPD:** Sleep 2-speed Startup Control bit⁽¹⁾

- 1 = Use FRC as SYSCLK until selected clock is ready
- 0 = Use the selected clock directly

bit 20-15 **Unimplemented:** Read as '0'

bit 14-12 **COSC<2:0>:** Current Oscillator Selection bits

- 111 = Internal Fast RC (FRC) Oscillator divided by FRCDIV<2:0> bits (FRCDIV)
- 110 = Back-up Fast RC (BFRC) Oscillator
- 101 = Internal Low-Power RC (LPRC) Oscillator
- 100 = Secondary Oscillator (SOSC)
- 011 = Reserved
- 010 = Primary Oscillator (Posc) (HS or EC)
- 001 = System PLL (SPLL)
- 000 = Internal Fast RC (FRC) Oscillator divided by FRCDIV<2:0> bits (FRCDIV)

bit 11 **Unimplemented:** Read as '0'

Note 1: The reset value for this bit depends on the setting of the IESO (DEVCFG1<7>) bit. When IESO = 1, the reset value is '1'. When IESO = 0, the reset value is '0'.

Note: Writes to this register require an unlock sequence. Refer to **Section 42. "Oscillators with Enhanced PLL"** (DS60001250) in the "PIC32 Family Reference Manual" for details.

PIC32MZ Embedded Connectivity with Floating Point Unit (EF) Family

REGISTER 8-1: OSCCON: OSCILLATOR CONTROL REGISTER

bit 10-8 **NOSC<2:0>**: New Oscillator Selection bits

111 = Internal Fast RC (FRC) Oscillator divided by FRCDIV<2:0> bits (FRCDIV)

110 = Reserved

101 = Internal Low-Power RC (LPRC) Oscillator

100 = Secondary Oscillator (SOSC)

011 = Reserved

010 = Primary Oscillator (POSC) (HS or EC)

001 = System PLL (SPLL)

000 = Internal Fast RC (FRC) Oscillator divided by FRCDIV<2:0> bits (FRCDIV)

On Reset, these bits are set to the value of the FNOSC<2:0> Configuration bits (DEVCFG1<2:0>).

bit 7 **CLKLOCK**: Clock Selection Lock Enable bit

1 = Clock and PLL selections are locked

0 = Clock and PLL selections are not locked and may be modified

bit 6-5 **Unimplemented**: Read as '0'

bit 4 **SLPEN**: Sleep Mode Enable bit

1 = Device will enter Sleep mode when a WAIT instruction is executed

0 = Device will enter Idle mode when a WAIT instruction is executed

bit 3 **CF**: Clock Fail Detect bit

1 = FSCM has detected a clock failure

0 = No clock failure has been detected

bit 2 **Unimplemented**: Read as '0'

bit 1 **SOSCEN**: Secondary Oscillator (SOSC) Enable bit

1 = Enable Secondary Oscillator

0 = Disable Secondary Oscillator

bit 0 **OSWEN**: Oscillator Switch Enable bit⁽¹⁾

1 = Initiate an oscillator switch to selection specified by NOSC<2:0> bits

0 = Oscillator switch is complete

Note 1: The reset value for this bit depends on the setting of the IESO (DEVCFG1<7>) bit. When IESO = 1, the reset value is '1'. When IESO = 0, the reset value is '0'.

Note: Writes to this register require an unlock sequence. Refer to **Section 42. "Oscillators with Enhanced PLL"** (DS60001250) in the *"PIC32 Family Reference Manual"* for details.

PIC32MZ Embedded Connectivity with Floating Point Unit (EF) Family

REGISTER 8-2: OSCTUN: FRC TUNING REGISTER

| Bit Range | Bit 31/23/15/7 | Bit 30/22/14/6 | Bit 29/21/13/5 | Bit 28/20/12/4 | Bit 27/19/11/3 | Bit 26/18/10/2 | Bit 25/17/9/1 | Bit 24/16/8/0 |
|-----------|----------------|----------------|-------------------------|----------------|----------------|----------------|---------------|---------------|
| 31:24 | U-0 | U-0 | U-0 | U-0 | U-0 | U-0 | U-0 | U-0 |
| | — | — | — | — | — | — | — | — |
| 23:16 | U-0 | R-0 | U-0 | U-0 | U-0 | U-0 | U-0 | U-0 |
| | — | — | — | — | — | — | — | — |
| 15:8 | U-0 | R-0 | U-0 | U-0 | U-0 | U-0 | U-0 | U-0 |
| | — | — | — | — | — | — | — | — |
| 7:0 | U-0 | U-0 | R/W-0 | R/W-0 | R/W-0 | R/W-0 | R/W-0 | R/W-0 |
| | — | — | TUN<5:0> ⁽¹⁾ | | | | | |

Legend:

R = Readable bit
-n = Value at POR

W = Writable bit
'1' = Bit is set

U = Unimplemented bit, read as '0'
'0' = Bit is cleared
x = Bit is unknown

bit 31-6 **Unimplemented:** Read as '0'

bit 5-0 **TUN<5:0>**: FRC Oscillator Tuning bits⁽¹⁾

100000 = Center frequency -2%

100001 =

•

•

•

111111 =

000000 = Center frequency; Oscillator runs at nominal frequency (8 MHz)

000001 =

•

•

•

011110 =

011111 = Center frequency +2%

Note 1: OSCTUN functionality has been provided to help customers compensate for temperature effects on the FRC frequency over a wide range of temperatures. The tuning step size is an approximation, and is neither characterized, nor tested.

Note: Writes to this register require an unlock sequence. Refer to **Section 42. "Oscillators with Enhanced PLL"** (DS60001250) in the *"PIC32 Family Reference Manual"* for details.

PIC32MZ Embedded Connectivity with Floating Point Unit (EF) Family

REGISTER 8-3: SPLLCN: SYSTEM PLL CONTROL REGISTER

| Bit Range | Bit 31/23/15/7 | Bit 30/22/14/6 | Bit 29/21/13/5 | Bit 28/20/12/4 | Bit 27/19/11/3 | Bit 26/18/10/2 | Bit 25/17/9/1 | Bit 24/16/8/0 |
|-----------|----------------|----------------|----------------|----------------|----------------|----------------|---------------|---------------|
| 31:24 | U-0 | U-0 | U-0 | U-0 | U-0 | R/W-y | R/W-y | R/W-y |
| | — | — | — | — | — | PLLODIV<2:0> | | |
| 23:16 | U-0 | R/W-y | R/W-y | R/W-y | R/W-y | R/W-y | R/W-y | R/W-y |
| | — | PLLMULT<6:0> | | | | | | |
| 15:8 | U-0 | U-0 | U-0 | U-0 | U-0 | R/W-y | R/W-y | R/W-y |
| | — | PLLIDIV<2:0> | | | | | | |
| 7:0 | R/W-y | U-0 | U-0 | U-0 | U-0 | R/W-y | R/W-y | R/W-y |
| | PLLICK | — | — | — | — | PLLRANGE<2:0> | | |

| | |
|-------------------|--|
| Legend: | y = Value set from Configuration bits on POR |
| R = Readable bit | W = Writable bit U = Unimplemented bit, read as '0' |
| -n = Value at POR | '1' = Bit is set '0' = Bit is cleared x = Bit is unknown |

bit 31-27 **Unimplemented:** Read as '0'

bit 26-24 **PLLODIV<2:0>:** System PLL Output Clock Divider bits

- 111 = PLL Divide by 32
- 110 = PLL Divide by 32
- 101 = PLL Divide by 32
- 100 = PLL Divide by 16
- 011 = PLL Divide by 8
- 010 = PLL Divide by 4
- 001 = PLL Divide by 2
- 000 = PLL Divide by 2

The default setting is specified by the FPLLODIV<2:0> Configuration bits in the DEVCFG2 register. Refer to [Register 34-5](#) in [Section 34.0 "Special Features"](#) for information.

bit 23 **Unimplemented:** Read as '0'

bit 22-16 **PLLMULT<6:0>:** System PLL Multiplier bits

- 1111111 = Multiply by 128
- 1111110 = Multiply by 127
- 1111101 = Multiply by 126
- 1111100 = Multiply by 125
-
-
-
- 0000000 = Multiply by 1

The default setting is specified by the FPLLMULT<6:0> Configuration bits in the DEVCFG2 register. Refer to [Register 34-5](#) in [Section 34.0 "Special Features"](#) for information.

bit 15-11 **Unimplemented:** Read as '0'

Note 1: Writes to this register require an unlock sequence. Refer to [Section 42. "Oscillators with Enhanced PLL"](#) (DS60001250) in the *"PIC32 Family Reference Manual"* for details.

2: Writes to this register are not allowed if the SPLL is selected as a clock source (COSC<2:0> = 001).

PIC32MZ Embedded Connectivity with Floating Point Unit (EF) Family

REGISTER 8-3: SPLLCON: SYSTEM PLL CONTROL REGISTER

bit 10-8 **PLLIDIV<2:0>**: System PLL Input Clock Divider bits

111 = Divide by 8
110 = Divide by 7
101 = Divide by 6
100 = Divide by 5
011 = Divide by 4
010 = Divide by 3
001 = Divide by 2
000 = Divide by 1

The default setting is specified by the FPLLIDIV<2:0> Configuration bits in the DEVCFG2 register. If the PLLICLK is set for FRC, this setting is ignored by the PLL and the divider is set for Divide-by-1. Refer to Register 34-5 in Section 34.0 “Special Features” for information.

bit 7 **PLLICLK**: System PLL Input Clock Source bit

1 = FRC is selected as the input to the System PLL
0 = Posc is selected as the input to the System PLL

The POR default is specified by the FPLLICLK Configuration bit in the DEVCFG2 register. Refer to Register 34-5 in Section 34.0 “Special Features” for information.

bit 6-3 **Unimplemented**: Read as '0'

bit 2-0 **PLLRRANGE<2:0>**: System PLL Frequency Range Selection bits

111 = Reserved
110 = Reserved
101 = 34-64 MHz
100 = 21-42 MHz
011 = 13-26 MHz
010 = 8-16 MHz
001 = 5-10 MHz
000 = Bypass

The default setting is specified by the FPLLRRNG<2:0> Configuration bits in the DEVCFG2 register. Refer to Register 34-5 in Section 34.0 “Special Features” for information.

Note 1: Writes to this register require an unlock sequence. Refer to Section 42. “Oscillators with Enhanced PLL” (DS60001250) in the “PIC32 Family Reference Manual” for details.

2: Writes to this register are not allowed if the SPLL is selected as a clock source (COSC<2:0> = 001).

PIC32MZ Embedded Connectivity with Floating Point Unit (EF) Family

REGISTER 8-4: REFOxCON: REFERENCE OSCILLATOR CONTROL REGISTER ('x' = 1-4)

| Bit Range | Bit 31/23/15/7 | Bit 30/22/14/6 | Bit 29/21/13/5 | Bit 28/20/12/4 | Bit 27/19/11/3 | Bit 26/18/10/2 | Bit 25/17/9/1 | Bit 24/16/8/0 |
|-----------|---------------------------|----------------|----------------|----------------|---------------------|----------------|---------------|-----------------------|
| 31:24 | U-0 | R/W-0 | R/W-0 | R/W-0 | R/W-0 | R/W-0 | R/W-0 | R/W-0 |
| | RODIV<14:8> | | | | | | | |
| 23:16 | R/W-0 | R/W-0 | R/W-0 | R/W-0 | R/W-0 | R/W-0 | R/W-0 | R/W-0 |
| | RODIV<7:0> | | | | | | | |
| 15:8 | R/W-0 | U-0 | R/W-0 | R/W-0 | R/W-0 | U-0 | R/W-0, HC | R-0, HS, HC |
| | ON ⁽¹⁾ | — | SIDL | OE | RSLP ⁽²⁾ | — | DIVSWEN | ACTIVE ⁽¹⁾ |
| 7:0 | U-0 | U-0 | U-0 | U-0 | R/W-0 | R/W-0 | R/W-0 | R/W-0 |
| | ROSEL<3:0> ⁽³⁾ | | | | | | | |

| | | |
|-------------------|-----------------------|------------------------------------|
| Legend: | HC = Hardware Cleared | HS = Hardware Set |
| R = Readable bit | W = Writable bit | U = Unimplemented bit, read as '0' |
| -n = Value at POR | '1' = Bit is set | '0' = Bit is cleared |
| | | x = Bit is unknown |

- bit 31 **Unimplemented:** Read as '0'
- bit 30-16 **RODIV<14:0>** Reference Clock Divider bits
The value selects the reference clock divider bits (see [Figure 8-1](#) for details). A value of '0' selects no divider.
- bit 15 **ON:** Output Enable bit⁽¹⁾
1 = Reference Oscillator Module enabled
0 = Reference Oscillator Module disabled
- bit 14 **Unimplemented:** Read as '0'
- bit 13 **SIDL:** Peripheral Stop in Idle Mode bit
1 = Discontinue module operation when device enters Idle mode
0 = Continue module operation in Idle mode
- bit 12 **OE:** Reference Clock Output Enable bit
1 = Reference clock is driven out on REFCLKOx pin
0 = Reference clock is not driven out on REFCLKOx pin
- bit 11 **RSLP:** Reference Oscillator Module Run in Sleep bit⁽²⁾
1 = Reference Oscillator Module output continues to run in Sleep
0 = Reference Oscillator Module output is disabled in Sleep
- bit 10 **Unimplemented:** Read as '0'
- bit 9 **DIVSWEN:** Divider Switch Enable bit
1 = Divider switch is in progress
0 = Divider switch is complete
- bit 8 **ACTIVE:** Reference Clock Request Status bit⁽¹⁾
1 = Reference clock request is active
0 = Reference clock request is not active
- bit 7-4 **Unimplemented:** Read as '0'
- bit 3-0 **ROSEL<3:0>** Reference Clock Source Select bits⁽³⁾
 - 1111 = Reserved
 -
 -
 -
 - 1001 = BFRC
 - 1000 = REFCLKIx
 - 0111 = System PLL output
 - 0110 = Reserved
 - 0101 = SOSC
 - 0100 = LPRC
 - 0011 = FRC
 - 0010 = POSC
 - 0001 = PBCLK1
 - 0000 = SYSCLK

- Note 1:** Do not write to this register when the ON bit is not equal to the ACTIVE bit.
- 2:** This bit is ignored when the ROSEL<3:0> bits = 0000 or 0001.
- 3:** The ROSEL<3:0> bits should not be written while the ACTIVE bit is '1', as undefined behavior may result.

PIC32MZ Embedded Connectivity with Floating Point Unit (EF) Family

REGISTER 8-5: REFOxTRIM: REFERENCE OSCILLATOR TRIM REGISTER ('x' = 1-4)

| Bit Range | Bit 31/23/15/7 | Bit 30/22/14/6 | Bit 29/21/13/5 | Bit 28/20/12/4 | Bit 27/19/11/3 | Bit 26/18/10/2 | Bit 25/17/9/1 | Bit 24/16/8/0 |
|-------------|----------------|----------------|----------------|----------------|----------------|----------------|---------------|---------------|
| 31:24 | R/W-0 | R/W-0 | R/W-0 | R/W-0 | R/W-0 | R/W-0 | R/W-0 | R/W-0 |
| ROTRIM<8:1> | | | | | | | | |
| 23:16 | R/W-0 | R-0 | U-0 | U-0 | U-0 | U-0 | U-0 | U-0 |
| | ROTRIM<0> | — | — | — | — | — | — | — |
| 15:8 | U-0 | R-0 | U-0 | U-0 | U-0 | U-0 | U-0 | U-0 |
| | — | — | — | — | — | — | — | — |
| 7:0 | U-0 | U-0 | U-0 | U-0 | U-0 | U-0 | U-0 | U-0 |
| | — | — | — | — | — | — | — | — |

Legend:

R = Readable bit

W = Writable bit

U = Unimplemented bit, read as '0'

-n = Value at POR

'1' = Bit is set

'0' = Bit is cleared

x = Bit is unknown

bit 31-23 **ROTRIM<8:0>**: Reference Oscillator Trim bits

111111111 = 511/512 divisor added to RODIV value

111111110 = 510/512 divisor added to RODIV value

•

•

•

100000000 = 256/512 divisor added to RODIV value

•

•

•

000000010 = 2/512 divisor added to RODIV value

000000001 = 1/512 divisor added to RODIV value

000000000 = 0 divisor added to RODIV value

bit 22-0 **Unimplemented**: Read as '0'

Note 1: While the ON bit (REFOxCON<15>) is '1', writes to this register do not take effect until the DIVSWEN bit is also set to '1'.

2: Do not write to this register when the ON bit (REFOxCON<15>) is not equal to the ACTIVE bit (REFOxCON<8>).

3: Specified values in this register do not take effect if RODIV<14:0> (REFOxCON<30:16>) = 0.

PIC32MZ Embedded Connectivity with Floating Point Unit (EF) Family

REGISTER 8-6: PBxDIV: PERIPHERAL BUS 'x' CLOCK DIVISOR CONTROL REGISTER ('x' = 1-7)

| Bit Range | Bit 31/23/15/7 | Bit 30/22/14/6 | Bit 29/21/13/5 | Bit 28/20/12/4 | Bit 27/19/11/3 | Bit 26/18/10/2 | Bit 25/17/9/1 | Bit 24/16/8/0 |
|-----------|----------------------------|----------------|----------------|----------------|-----------------|----------------|---------------|---------------|
| 31:24 | U-0 — | U-0 — | U-0 — | U-0 — | U-0 — | U-0 — | U-0 — | U-0 — |
| 23:16 | U-0 — | U-0 — | U-0 — | U-0 — | U-0 — | U-0 — | U-0 — | U-0 — |
| 15:8 | R/W-1 ON ⁽¹⁾ | U-0 — | U-0 — | U-0 — | R-1 PBDIVRDY | U-0 — | U-0 — | U-0 — |
| | U-0 — | R/W-x | R/W-x | R/W-x | R/W-x | R/W-x | R/W-x | R/W-x |
| 7:0 | PBDIV<6:0> | | | | | | | |

Legend:

R = Readable bit
-n = Value at POR

W = Writable bit
'1' = Bit is set

U = Unimplemented bit, read as '0'
'0' = Bit is cleared
x = Bit is unknown

bit 31-16 **Unimplemented:** Read as '0'

bit 15 **ON:** Peripheral Bus 'x' Output Clock Enable bit⁽¹⁾

1 = Output clock is enabled
0 = Output clock is disabled

bit 14-12 **Unimplemented:** Read as '0'

bit 11 **PBDIVRDY:** Peripheral Bus 'x' Clock Divisor Ready bit

1 = Clock divisor logic is not switching divisors and the PBxDIV<6:0> bits may be written
0 = Clock divisor logic is currently switching values and the PBxDIV<6:0> bits cannot be written

bit 10-7 **Unimplemented:** Read as '0'

bit 6-0 **PBDIV<6:0>:** Peripheral Bus 'x' Clock Divisor Control bits

11111111 = PBCLKx is SYSCLK divided by 128
11111110 = PBCLKx is SYSCLK divided by 127

•
•
•

0000011 = PBCLKx is SYSCLK divided by 4
0000010 = PBCLKx is SYSCLK divided by 3
0000001 = PBCLKx is SYSCLK divided by 2 (default value for x ≠ 7)
0000000 = PBCLKx is SYSCLK divided by 1 (default value for x = 7)

Note 1: The clock for peripheral bus 1 cannot be turned off. Therefore, the ON bit in the PB1DIV register cannot be written as a '0'.

Note: Writes to this register require an unlock sequence. Refer to **Section 42. "Oscillators with Enhanced PLL"** (DS60001250) in the "PIC32 Family Reference Manual" for details.

PIC32MZ Embedded Connectivity with Floating Point Unit (EF) Family

REGISTER 8-7: SLEWCON: OSCILLATOR SLEW CONTROL REGISTER

| Bit Range | Bit 31/23/15/7 | Bit 30/22/14/6 | Bit 29/21/13/5 | Bit 28/20/12/4 | Bit 27/19/11/3 | Bit 26/18/10/2 | Bit 25/17/9/1 | Bit 24/16/8/0 |
|-----------|----------------|----------------|----------------|----------------|----------------------------|----------------|---------------|---------------|
| 31:24 | U-0 | U-0 | U-0 | U-0 | U-0 | U-0 | U-0 | U-0 |
| | — | — | — | — | — | — | — | — |
| 23:16 | U-0 | U-0 | U-0 | U-0 | R/W-0 | R/W-0 | R/W-0 | R/W-0 |
| | — | — | — | — | SYSDIV<3:0> ⁽¹⁾ | | | |
| 15:8 | U-0 | U-0 | U-0 | U-0 | U-0 | R/W-0 | R/W-1 | R/W-0 |
| | — | — | — | — | — | SLWDIV<2:0> | | |
| 7:0 | U-0 | U-0 | U-0 | U-0 | U-0 | R/W-1 | R/W-0 | R-0, HS, HC |
| | — | — | — | — | — | UPEN | DNEN | BUSY |

| | | |
|-------------------|-----------------------|--|
| Legend: | HC = Hardware Cleared | HS = Hardware Set |
| R = Readable bit | W = Writable bit | U = Unimplemented bit, read as '0' |
| -n = Value at POR | '1' = Bit is set | '0' = Bit is cleared x = Bit is unknown |

bit 31-20 **Unimplemented:** Read as '0'

bit 19-16 **SYSDIV<3:0>:** System Clock Divide Control bits⁽¹⁾

1111 = SYSCLK is divided by 16

1110 = SYSCLK is divided by 15

•

•

•

0010 = SYSCLK is divided by 3

0001 = SYSCLK is divided by 2

0000 = SYSCLK is not divided

bit 15-11 **Unimplemented:** Read as '0'

bit 10-8 **SLWDIV<2:0>:** Slew Divisor Steps Control bits

These bits control the maximum division steps used when slewing during a frequency change.

111 = Steps are divide by 128, 64, 32, 16, 8, 4, 2, and then no divisor

110 = Steps are divide by 64, 32, 16, 8, 4, 2, and then no divisor

101 = Steps are divide by 32, 16, 8, 4, 2, and then no divisor

100 = Steps are divide by 16, 8, 4, 2, and then no divisor

011 = Steps are divide by 8, 4, 2, and then no divisor

010 = Steps are divide by 4, 2, and then no divisor

001 = Steps are divide by 2, and then no divisor

000 = No divisor is used during slewing

Note: The steps apply in reverse order (i.e., 2, 4, 8, etc.) during a downward frequency change.

bit 7-3 **Unimplemented:** Read as '0'

bit 2 **UPEN:** Upward Slew Enable bit

1 = Slewing enabled for switching to a higher frequency

0 = Slewing disabled for switching to a higher frequency

bit 1 **DNEN:** Downward Slew Enable bit

1 = Slewing enabled for switching to a lower frequency

0 = Slewing disabled for switching to a lower frequency

bit 0 **BUSY:** Clock Switching Slewing Active Status bit

1 = Clock frequency is being actively slewed to the new frequency

0 = Clock switch has reached its final value

Note 1: The SYSDIV<3:0> bit settings are ignored if both UPEN and DNEN = 0, and SYSCLK will be divided by 1.

PIC32MZ Embedded Connectivity with Floating Point Unit (EF) Family

REGISTER 8-8: CLKSTAT: OSCILLATOR CLOCK STATUS REGISTER

| Bit Range | Bit 31/23/15/7 | Bit 30/22/14/6 | Bit 29/21/13/5 | Bit 28/20/12/4 | Bit 27/19/11/3 | Bit 26/18/10/2 | Bit 25/17/9/1 | Bit 24/16/8/0 |
|-----------|----------------|----------------|----------------|----------------|----------------|----------------|---------------|---------------|
| 31:24 | U-0 | U-0 | U-0 | U-0 | U-0 | U-0 | U-0 | U-0 |
| | — | — | — | — | — | — | — | — |
| 23:16 | U-0 | U-0 | U-0 | U-0 | U-0 | U-0 | U-0 | U-0 |
| | — | — | — | — | — | — | — | — |
| 15:8 | U-0 | U-0 | U-0 | U-0 | U-0 | U-0 | U-0 | U-0 |
| | — | — | — | — | — | — | — | — |
| 7:0 | U-0 | U-0 | R-0 | R-0 | U-0 | R-0 | R-0 | R-0 |
| | — | — | LPRCRDY | SOSCRDY | — | POSCRDY | DIVSPLLRDY | FRCRDY |

Legend:

R = Readable bit
-n = Value at POR

W = Writable bit
'1' = Bit is set

U = Unimplemented bit, read as '0'
'0' = Bit is cleared
x = Bit is unknown

- bit 31-6 **Unimplemented:** Read as '0'
- bit 5 **LPRCRDY:** Low-Power RC (LPRC) Oscillator Ready Status bit
 - 1 = LPRC is stable and ready
 - 0 = LPRC is disabled or not operating
- bit 4 **SOSCRDY:** Secondary Oscillator (SOSC) Ready Status bit
 - 1 = SOSC is stable and ready
 - 0 = SOSC is disabled or not operating
- bit 3 **Unimplemented:** Read as '0'
- bit 2 **POSCRDY:** Primary Oscillator (Posc) Ready Status bit
 - 1 = Posc is stable and ready
 - 0 = Posc is disabled or not operating
- bit 1 **DIVSPLLRDY:** Divided System PLL Ready Status bit
 - 1 = Divided System PLL is ready
 - 0 = Divided System PLL is not ready
- bit 0 **FRCRDY:** Fast RC (FRC) Oscillator Ready Status bit
 - 1 = FRC is stable and ready
 - 0 = FRC is disabled for not operating

PIC32MZ Embedded Connectivity with Floating Point Unit (EF) Family

NOTES:

9.0 PREFETCH MODULE

Note: This data sheet summarizes the features of the PIC32MZ EF family of devices. It is not intended to be a comprehensive reference source. To complement the information in this data sheet, refer to **Section 41. “Prefetch Module for Devices with L1 CPU Cache”** (DS60001183) in the *“PIC32 Family Reference Manual”*, which is available from the Microchip web site (www.microchip.com/PIC32).

The Prefetch module is a performance enhancing module that is included in PIC32MZ EF family devices. When running at high-clock rates, Wait states must be inserted into Program Flash Memory (PFM) read transactions to meet the access time of the PFM. Wait states can be hidden to the core by prefetching and storing instructions in a temporary holding area that the CPU can access quickly. Although the data path to the CPU is 32 bits wide, the data path to the PFM is 128 bits wide. This wide data path provides the same bandwidth to the CPU as a 32-bit path running at four times the frequency.

The Prefetch module holds a subset of PFM in temporary holding spaces known as lines. Each line contains a tag and data field. Normally, the lines hold a copy of what is currently in memory to make instructions or data available to the CPU without Flash Wait states.

Key features include:

- 4x16 byte fully-associative lines
- One line for CPU instructions
- One line for CPU data
- Two lines for peripheral data
- 16-byte parallel memory fetch
- Configurable predictive prefetch
- Error detection and correction

A simplified block diagram of the Prefetch module is shown in [Figure 9-1](#).

FIGURE 9-1: PREFETCH MODULE BLOCK DIAGRAM

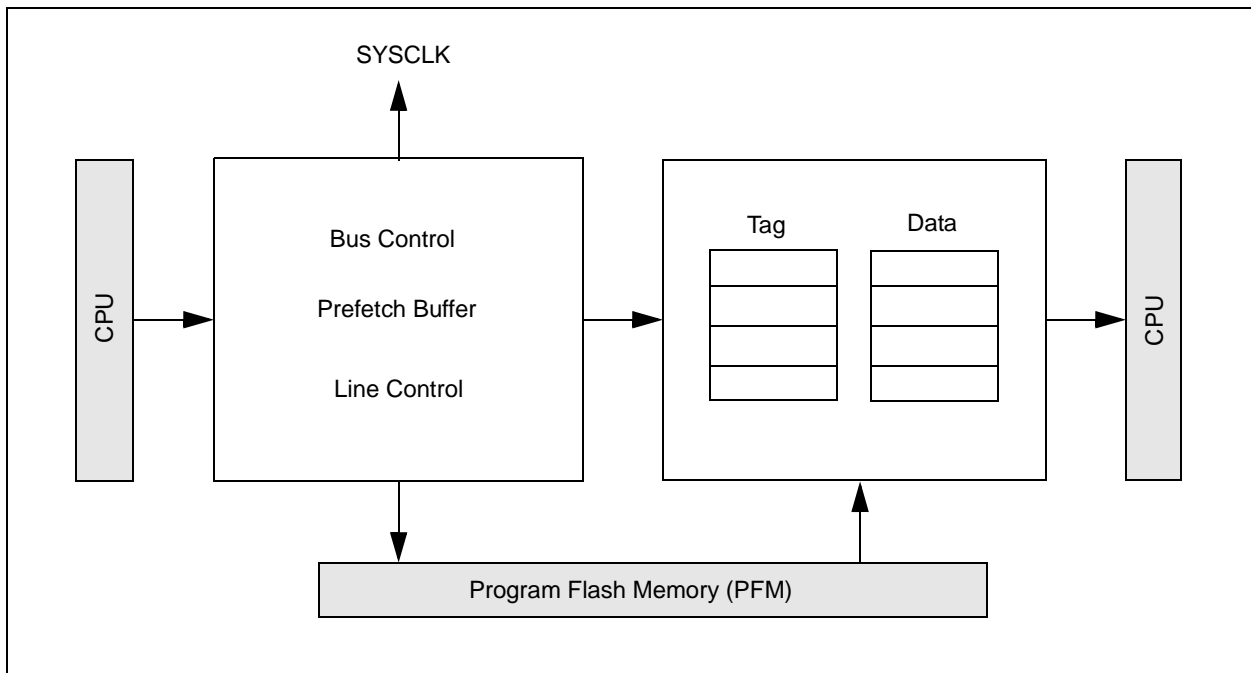

9.1 Prefetch Control Registers

TABLE 9-1: PREFETCH REGISTER MAP

| Virtual Address (BF8E_#) | Register Name (1) | Bit Range | Bits | | | | | | | | | | | | | | | | All Resets |
|--------------------------|-------------------|-----------|-------|-------|-------|-------|---------|----------|------|------|------|------|------|---------------|------|------|------------|------|------------|
| | | | 31/15 | 30/14 | 29/13 | 28/12 | 27/11 | 26/10 | 25/9 | 24/8 | 23/7 | 22/6 | 21/5 | 20/4 | 19/3 | 18/2 | 17/1 | 16/0 | |
| 0000 | PRECON | 31:16 | — | — | — | — | — | PFMSECEN | — | — | — | — | — | — | — | — | — | — | 0000 |
| | | 15:0 | — | — | — | — | — | — | — | — | — | — | — | PREFEN<1:0> | — | — | PFMWS<2:0> | — | 0007 |
| 0010 | PRESTAT | 31:16 | — | — | — | — | PFMDDED | PFMSEC | — | — | — | — | — | — | — | — | — | — | 0000 |
| | | 15:0 | — | — | — | — | — | — | — | — | — | — | — | PFMSECNT<7:0> | — | — | — | — | 0000 |

Legend: x = unknown value on Reset, — = unimplemented, read as '0'. Reset values are shown in hexadecimal.

Note 1: All registers in this table have corresponding CLR, SET and INV registers at its virtual address, plus an offset of 0x4, 0x8 and 0xC, respectively. See [Section 12.3 “CLR, SET, and INV Registers”](#) for more information.

PIC32MZ Embedded Connectivity with Floating Point Unit (EF) Family

REGISTER 9-1: PRECON: PREFETCH MODULE CONTROL REGISTER

| Bit Range | Bit 31/23/15/7 | Bit 30/22/14/6 | Bit 29/21/13/5 | Bit 28/20/12/4 | Bit 27/19/11/3 | Bit 26/18/10/2 | Bit 25/17/9/1 | Bit 24/16/8/0 |
|-----------|-------------------|-------------------|-------------------|-------------------|-------------------|---------------------------|------------------|------------------|
| 31:24 | U-0 | U-0 | U-0 | U-0 | U-0 | R/W-0 | U-0 | U-0 |
| | — | — | — | — | — | PFMSECEN | — | — |
| 23:16 | U-0 | U-0 | U-0 | U-0 | U-0 | U-0 | U-0 | U-0 |
| | — | — | — | — | — | — | — | — |
| 15:8 | U-0 | U-0 | U-0 | U-0 | U-0 | U-0 | U-0 | U-0 |
| | — | — | — | — | — | — | — | — |
| 7:0 | U-0 | U-0 | R/W-0 | R/W-0 | U-0 | R/W-1 | R/W-1 | R/W-1 |
| | — | — | PREFEN<1:0> | | — | PFMWS<2:0> ⁽¹⁾ | | |

Legend:

| | | |
|-------------------|------------------|--|
| R = Readable bit | W = Writable bit | U = Unimplemented bit, read as '0' |
| -n = Value at POR | '1' = Bit is set | '0' = Bit is cleared x = Bit is unknown |

bit 31-27 **Unimplemented:** Read as '0'

bit 26 **PFMSECEN:** Flash SEC Interrupt Enable bit
 1 = Generate an interrupt when the PFMSEC bit (PRESTAT<26>) is set
 0 = Do not generate an interrupt when the PFMSEC bit is set

bit 25-6 **Unimplemented:** Read as '0'

bit 5-4 **PREFEN<1:0>:** Predictive Prefetch Enable bits
 11 = Enable predictive prefetch for any address
 10 = Enable predictive prefetch for CPU instructions and CPU data
 01 = Enable predictive prefetch for CPU instructions only
 00 = Disable predictive prefetch

bit 3 **Unimplemented:** Read as '0'

bit 2-0 **PFMWS<2:0>:** PFM Access Time Defined in Terms of SYSCLK Wait States bits⁽¹⁾
 111 = Seven Wait states
 •
 •
 •
 010 = Two Wait states
 001 = One Wait state
 000 = Zero Wait states

Note 1: For the Wait states to SYSCLK relationship, refer to [Table 37-13](#) in [Section 37.0 “Electrical Characteristics”](#).

PIC32MZ Embedded Connectivity with Floating Point Unit (EF) Family

REGISTER 9-2: PRESTAT: PREFETCH MODULE STATUS REGISTER

| Bit Range | Bit 31/23/15/7 | Bit 30/22/14/6 | Bit 29/21/13/5 | Bit 28/20/12/4 | Bit 27/19/11/3 | Bit 26/18/10/2 | Bit 25/17/9/1 | Bit 24/16/8/0 |
|-----------|----------------|----------------|----------------|----------------|----------------|----------------|---------------|---------------|
| 31:24 | U-0 | U-0 | U-0 | U-0 | R/W-0, HS | R/W-0, HS | U-0 | U-0 |
| | — | — | — | — | PFMDED | PFMSEC | — | — |
| 23:16 | U-0 | U-0 | U-0 | U-0 | U-0 | U-0 | U-0 | U-0 |
| | — | — | — | — | — | — | — | — |
| 15:8 | U-0 | U-0 | U-0 | U-0 | U-0 | U-0 | U-0 | U-0 |
| | — | — | — | — | — | — | — | — |
| 7:0 | R/W-0, HS | R/W-0, HS | R/W-0, HS | R/W-0, HS | R/W-0, HS | R/W-0, HS | R/W-0, HS | R/W-0, HS |
| | PFMSECCNT<7:0> | | | | | | | |

| | |
|-------------------|------------------------------------|
| Legend: | HS = Hardware Set |
| R = Readable bit | W = Writable bit |
| -n = Value at POR | '1' = Bit is set |
| | '0' = Bit is cleared |
| | x = Bit is unknown |
| | U = Unimplemented bit, read as '0' |

bit 31-28 **Unimplemented:** Read as '0'

bit 27 **PFMDED:** Flash Double-bit Error Detected (DED) Status bit
 This bit is set in hardware and can only be cleared (i.e., set to '0') in software.
 1 = A DED error has occurred
 0 = A DED error has not occurred

bit 26 **PFMSEC:** Flash Single-bit Error Corrected (SEC) Status bit
 1 = A SEC error occurred when PFMSECCNT<7:0> was equal to zero
 0 = A SEC error has not occurred

bit 25-8 **Unimplemented:** Read as '0'

bit 7-0 **PFMSECCNT<7:0>:** Flash SEC Count bits
 11111111 - 00000000 = SEC count

10.0 DIRECT MEMORY ACCESS (DMA) CONTROLLER

Note: This data sheet summarizes the features of the PIC32MZ EF family of devices. It is not intended to be a comprehensive reference source. To complement the information in this data sheet, refer to **Section 31. “Direct Memory Access (DMA) Controller”** (DS60001117) in the *“PIC32 Family Reference Manual”*, which is available from the Microchip web site (www.microchip.com/PIC32).

The Direct Memory Access (DMA) Controller is a bus master module useful for data transfers between different devices without CPU intervention. The source and destination of a DMA transfer can be any of the memory mapped modules existent in the device such as SPI, UART, PMP, etc., or memory itself.

Key features include:

- Eight identical channels, each featuring:
 - Auto-increment source and destination address registers
 - Source and destination pointers
 - Memory to memory and memory to peripheral transfers
- Automatic word-size detection:
 - Transfer granularity, down to byte level
 - Bytes need not be word-aligned at source and destination
- Fixed priority channel arbitration

- Flexible DMA channel operating modes:
 - Manual (software) or automatic (interrupt) DMA requests
 - One-Shot or Auto-Repeat Block Transfer modes
 - Channel-to-channel chaining
- Flexible DMA requests:
 - A DMA request can be selected from any of the peripheral interrupt sources
 - Each channel can select any (appropriate) observable interrupt as its DMA request source
 - A DMA transfer abort can be selected from any of the peripheral interrupt sources
 - Up to 2-byte Pattern (data) match transfer termination
- Multiple DMA channel status interrupts:
 - DMA channel block transfer complete
 - Source empty or half empty
 - Destination full or half full
 - DMA transfer aborted due to an external event
 - Invalid DMA address generated
- DMA debug support features:
 - Most recent error address accessed by a DMA channel
 - Most recent DMA channel to transfer data
- CRC Generation module:
 - CRC module can be assigned to any of the available channels
 - CRC module is highly configurable

FIGURE 10-1: DMA BLOCK DIAGRAM

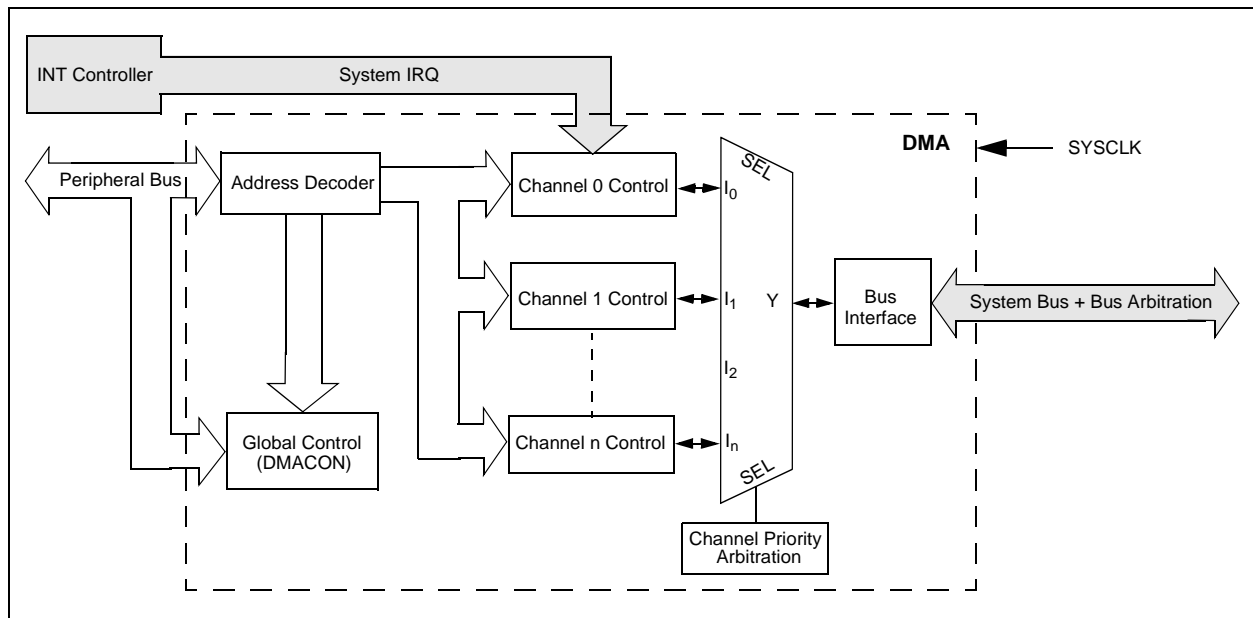

10.1 DMA Control Registers

TABLE 10-1: DMA GLOBAL REGISTER MAP

| Virtual Address (BF81_#) | Register Name ⁽¹⁾ | Bit Range | Bits | | | | | | | | | | | | | | | All Resets | |
|-----------------------------|---------------------------------|-----------|---------------|-------|-------|---------|---------|-------|------|------|------|------|------|------|------|------------|------|------------|------|
| | | | 31/15 | 30/14 | 29/13 | 28/12 | 27/11 | 26/10 | 25/9 | 24/8 | 23/7 | 22/6 | 21/5 | 20/4 | 19/3 | 18/2 | 17/1 | | 16/0 |
| 1000 | DMACON | 31:16 | — | — | — | — | — | — | — | — | — | — | — | — | — | — | — | — | 0000 |
| | | 15:0 | ON | — | — | SUSPEND | DMABUSY | — | — | — | — | — | — | — | — | — | — | — | 0000 |
| 1010 | DMASTAT | 31:16 | RDWR | — | — | — | — | — | — | — | — | — | — | — | — | — | — | — | 0000 |
| | | 15:0 | — | — | — | — | — | — | — | — | — | — | — | — | — | DMACH<2:0> | | | 0000 |
| 1020 | DMAADDR | 31:16 | DMAADDR<31:0> | | | | | | | | | | | | | | | 0000 | |
| | | 15:0 | DMAADDR<31:0> | | | | | | | | | | | | | | | 0000 | |

Legend: x = unknown value on Reset; — = unimplemented, read as '0'. Reset values are shown in hexadecimal.

Note 1: All registers in this table have corresponding CLR, SET and INV registers at its virtual address, plus an offset of 0x4, 0x8 and 0xC, respectively. See [Section 12.3 “CLR, SET, and INV Registers”](#) for more information.

TABLE 10-2: DMA CRC REGISTER MAP

| Virtual Address (BF81_#) | Register Name ⁽¹⁾ | Bit Range | Bits | | | | | | | | | | | | | | | All Resets | |
|-----------------------------|---------------------------------|-----------|----------------|-------|-----------|-----------|-------|-------|------|------|-------|--------|--------|------|------|------------|------|------------|------|
| | | | 31/15 | 30/14 | 29/13 | 28/12 | 27/11 | 26/10 | 25/9 | 24/8 | 23/7 | 22/6 | 21/5 | 20/4 | 19/3 | 18/2 | 17/1 | | 16/0 |
| 1030 | DCRCCON | 31:16 | — | — | BYTO<1:0> | WBO | — | — | BITO | — | — | — | — | — | — | — | — | — | 0000 |
| | | 15:0 | — | — | — | PLEN<4:0> | | | | | CRCEN | CRCAPP | CRCTYP | — | — | CRCCH<2:0> | | | 0000 |
| 1040 | DCRCDATA | 31:16 | DCRCDATA<31:0> | | | | | | | | | | | | | | | 0000 | |
| | | 15:0 | DCRCDATA<31:0> | | | | | | | | | | | | | | | 0000 | |
| 1050 | DCRCXOR | 31:16 | DCRCXOR<31:0> | | | | | | | | | | | | | | | 0000 | |
| | | 15:0 | DCRCXOR<31:0> | | | | | | | | | | | | | | | 0000 | |

Legend: x = unknown value on Reset; — = unimplemented, read as '0'. Reset values are shown in hexadecimal.

Note 1: All registers in this table have corresponding CLR, SET and INV registers at their virtual addresses, plus offsets of 0x4, 0x8 and 0xC, respectively. See [Section 12.3 “CLR, SET, and INV Registers”](#) for more information.

TABLE 10-3: DMA CHANNEL 0 THROUGH CHANNEL 7 REGISTER MAP

| Virtual Address (BF81_#) | Register Name ⁽¹⁾ | Bit Range | Bits | | | | | | | | | | | | | | | All Resets | |
|-----------------------------|---------------------------------|-----------|--------------|-------|----------|-------|----------|-------|------|------|--------|------|-------|-------|-------|------|--------|------------|------|
| | | | 31/15 | 30/14 | 29/13 | 28/12 | 27/11 | 26/10 | 25/9 | 24/8 | 23/7 | 22/6 | 21/5 | 20/4 | 19/3 | 18/2 | 17/1 | | 16/0 |
| 1060 | DCH0CON | 31:16 | CHPIGN<7:0> | | | | | | | | | | | | | | | 0000 | |
| | | 15:0 | CHBUSY | — | CHPIGNEN | — | CHPATLEN | — | — | — | CHCHNS | CHEN | CHAED | CHCHN | CHAEN | — | CHEDET | CHPRI<1:0> | 0000 |
| 1070 | DCH0ECON | 31:16 | CHAIRQ<7:0> | | | | | | | | | | | | | | | 00FF | |
| | | 15:0 | CHSIRQ<7:0> | | | | | | | | | | | | | | | FF00 | |
| 1080 | DCH0INT | 31:16 | — | — | — | — | — | — | — | — | — | — | — | — | — | — | — | — | 0000 |
| | | 15:0 | — | — | — | — | — | — | — | — | — | — | — | — | — | — | — | — | 0000 |
| 1090 | DCH0SSA | 31:16 | CHSSA<31:0> | | | | | | | | | | | | | | | 0000 | |
| | | 15:0 | | | | | | | | | | | | | | | | 0000 | |
| 10A0 | DCH0DSA | 31:16 | CHDSA<31:0> | | | | | | | | | | | | | | | 0000 | |
| | | 15:0 | | | | | | | | | | | | | | | | 0000 | |
| 10B0 | DCH0SSIZ | 31:16 | — | — | — | — | — | — | — | — | — | — | — | — | — | — | — | — | 0000 |
| | | 15:0 | CHSSIZ<15:0> | | | | | | | | | | | | | | | 0000 | |
| 10C0 | DCH0DSIZ | 31:16 | — | — | — | — | — | — | — | — | — | — | — | — | — | — | — | — | 0000 |
| | | 15:0 | CHDSIZ<15:0> | | | | | | | | | | | | | | | 0000 | |
| 10D0 | DCH0SPTR | 31:16 | — | — | — | — | — | — | — | — | — | — | — | — | — | — | — | — | 0000 |
| | | 15:0 | CHSPTR<15:0> | | | | | | | | | | | | | | | 0000 | |
| 10E0 | DCH0DPTR | 31:16 | — | — | — | — | — | — | — | — | — | — | — | — | — | — | — | — | 0000 |
| | | 15:0 | CHDPTR<15:0> | | | | | | | | | | | | | | | 0000 | |
| 10F0 | DCH0CSIZ | 31:16 | — | — | — | — | — | — | — | — | — | — | — | — | — | — | — | — | 0000 |
| | | 15:0 | CHCSIZ<15:0> | | | | | | | | | | | | | | | 0000 | |
| 1100 | DCH0CPTR | 31:16 | — | — | — | — | — | — | — | — | — | — | — | — | — | — | — | — | 0000 |
| | | 15:0 | CHCPTR<15:0> | | | | | | | | | | | | | | | 0000 | |
| 1110 | DCH0DAT | 31:16 | — | — | — | — | — | — | — | — | — | — | — | — | — | — | — | — | 0000 |
| | | 15:0 | CHPDAT<15:0> | | | | | | | | | | | | | | | 0000 | |
| 1120 | DCH1CON | 31:16 | CHPIGN<7:0> | | | | | | | | | | | | | | | 0000 | |
| | | 15:0 | CHBUSY | — | CHPIGNEN | — | CHPATLEN | — | — | — | CHCHNS | CHEN | CHAED | CHCHN | CHAEN | — | CHEDET | CHPRI<1:0> | 0000 |
| 1130 | DCH1ECON | 31:16 | CHAIRQ<7:0> | | | | | | | | | | | | | | | 00FF | |
| | | 15:0 | CHSIRQ<7:0> | | | | | | | | | | | | | | | FF00 | |
| 1140 | DCH1INT | 31:16 | — | — | — | — | — | — | — | — | — | — | — | — | — | — | — | — | 0000 |
| | | 15:0 | — | — | — | — | — | — | — | — | — | — | — | — | — | — | — | — | 0000 |
| 1150 | DCH1SSA | 31:16 | CHSSA<31:0> | | | | | | | | | | | | | | | 0000 | |
| | | 15:0 | | | | | | | | | | | | | | | | 0000 | |
| 1160 | DCH1DSA | 31:16 | CHDSA<31:0> | | | | | | | | | | | | | | | 0000 | |
| | | 15:0 | | | | | | | | | | | | | | | | 0000 | |

Legend: x = unknown value on Reset; — = unimplemented, read as '0'. Reset values are shown in hexadecimal.

Note 1: All registers in this table have corresponding CLR, SET and INV registers at their virtual addresses, plus offsets of 0x4, 0x8 and 0xC, respectively. See [Section 12.3 “CLR, SET, and INV Registers”](#) for more information.

TABLE 10-3: DMA CHANNEL 0 THROUGH CHANNEL 7 REGISTER MAP (CONTINUED)

| Virtual Address (BF81_#) | Register Name ⁽¹⁾ | Bit Range | Bits | | | | | | | | | | | | | | | | All Resets |
|-----------------------------|---------------------------------|-----------|--------------|-------|----------|-------|----------|-------|------|-------------|--------|--------|--------|--------|--------|--------|------------|------|------------|
| | | | 31/15 | 30/14 | 29/13 | 28/12 | 27/11 | 26/10 | 25/9 | 24/8 | 23/7 | 22/6 | 21/5 | 20/4 | 19/3 | 18/2 | 17/1 | 16/0 | |
| 1170 | DCH1SSIZ | 31:16 | — | — | — | — | — | — | — | — | — | — | — | — | — | — | — | — | 0000 |
| | | 15:0 | CHSSIZ<15:0> | | | | | | | | | | | | | | | | 0000 |
| 1180 | DCH1DSIZ | 31:16 | — | — | — | — | — | — | — | — | — | — | — | — | — | — | — | — | 0000 |
| | | 15:0 | CHDSIZ<15:0> | | | | | | | | | | | | | | | | 0000 |
| 1190 | DCH1SPTR | 31:16 | — | — | — | — | — | — | — | — | — | — | — | — | — | — | — | — | 0000 |
| | | 15:0 | CHSPTR<15:0> | | | | | | | | | | | | | | | | 0000 |
| 11A0 | DCH1DPTR | 31:16 | — | — | — | — | — | — | — | — | — | — | — | — | — | — | — | — | 0000 |
| | | 15:0 | CHDPTR<15:0> | | | | | | | | | | | | | | | | 0000 |
| 11B0 | DCH1CSIZ | 31:16 | — | — | — | — | — | — | — | — | — | — | — | — | — | — | — | — | 0000 |
| | | 15:0 | CHCSIZ<15:0> | | | | | | | | | | | | | | | | 0000 |
| 11C0 | DCH1CPTR | 31:16 | — | — | — | — | — | — | — | — | — | — | — | — | — | — | — | — | 0000 |
| | | 15:0 | CHCPTR<15:0> | | | | | | | | | | | | | | | | 0000 |
| 11D0 | DCH1DAT | 31:16 | — | — | — | — | — | — | — | — | — | — | — | — | — | — | — | — | 0000 |
| | | 15:0 | CHPDAT<15:0> | | | | | | | | | | | | | | | | 0000 |
| 11E0 | DCH2CON | 31:16 | CHPIGN<7:0> | | | | | | | — | — | — | — | — | — | — | — | 0000 | |
| | | 15:0 | CHBUSY | — | CHPIGNEN | — | CHPATLEN | — | — | CHCHNS | CHEN | CHAED | CHCHN | CHAEN | — | CHEDET | CHPRI<1:0> | 0000 | |
| 11F0 | DCH2ECON | 31:16 | — | — | — | — | — | — | — | CHAIRQ<7:0> | | | | | | | | 00FF | |
| | | 15:0 | CHSIRQ<7:0> | | | | | | | CFORCE | CABORT | PATEN | SIRQEN | AIRQEN | — | — | — | FF00 | |
| 1200 | DCH2INT | 31:16 | — | — | — | — | — | — | — | CHSDIE | CHSHIE | CHDDIE | CHDHIE | CHBCIE | CHCCIE | CHTAIE | CHERIE | 0000 | |
| | | 15:0 | — | — | — | — | — | — | — | CHSDIF | CHSHIF | CHDDIF | CHDHIF | CHBCIF | CHCCIF | CHTAIF | CHERIF | 0000 | |
| 1210 | DCH2SSA | 31:16 | CHSSA<31:0> | | | | | | | | | | | | | | | | 0000 |
| | | 15:0 | CHSSA<31:0> | | | | | | | | | | | | | | | | 0000 |
| 1220 | DCH2DSA | 31:16 | CHDSA<31:0> | | | | | | | | | | | | | | | | 0000 |
| | | 15:0 | CHDSA<31:0> | | | | | | | | | | | | | | | | 0000 |
| 1230 | DCH2SSIZ | 31:16 | — | — | — | — | — | — | — | — | — | — | — | — | — | — | — | — | 0000 |
| | | 15:0 | CHSSIZ<15:0> | | | | | | | | | | | | | | | | 0000 |
| 1240 | DCH2DSIZ | 31:16 | — | — | — | — | — | — | — | — | — | — | — | — | — | — | — | — | 0000 |
| | | 15:0 | CHDSIZ<15:0> | | | | | | | | | | | | | | | | 0000 |
| 1250 | DCH2SPTR | 31:16 | — | — | — | — | — | — | — | — | — | — | — | — | — | — | — | — | 0000 |
| | | 15:0 | CHSPTR<15:0> | | | | | | | | | | | | | | | | 0000 |
| 1260 | DCH2DPTR | 31:16 | — | — | — | — | — | — | — | — | — | — | — | — | — | — | — | — | 0000 |
| | | 15:0 | CHDPTR<15:0> | | | | | | | | | | | | | | | | 0000 |
| 1270 | DCH2CSIZ | 31:16 | — | — | — | — | — | — | — | — | — | — | — | — | — | — | — | — | 0000 |
| | | 15:0 | CHCSIZ<15:0> | | | | | | | | | | | | | | | | 0000 |

Legend: x = unknown value on Reset; — = unimplemented, read as '0'. Reset values are shown in hexadecimal.

Note 1: All registers in this table have corresponding CLR, SET and INV registers at their virtual addresses, plus offsets of 0x4, 0x8 and 0xC, respectively. See [Section 12.3 “CLR, SET, and INV Registers”](#) for more information.

TABLE 10-3: DMA CHANNEL 0 THROUGH CHANNEL 7 REGISTER MAP (CONTINUED)

| Virtual Address (BF81_#) | Register Name ⁽¹⁾ | Bit Range | Bits | | | | | | | | | | | | | | | All Resets | |
|-----------------------------|---------------------------------|-----------|--------------|-------|----------|-------|----------|-------|------|-------------|--------|--------|--------|--------|--------|--------|------------|------------|------|
| | | | 31/15 | 30/14 | 29/13 | 28/12 | 27/11 | 26/10 | 25/9 | 24/8 | 23/7 | 22/6 | 21/5 | 20/4 | 19/3 | 18/2 | 17/1 | | 16/0 |
| 1280 | DCH2CPTR | 31:16 | — | — | — | — | — | — | — | — | — | — | — | — | — | — | — | — | 0000 |
| | | 15:0 | CHCPTR<15:0> | | | | | | | | | | | | | | | 0000 | |
| 1290 | DCH2DAT | 31:16 | — | — | — | — | — | — | — | — | — | — | — | — | — | — | — | — | 0000 |
| | | 15:0 | CHPDAT<15:0> | | | | | | | | | | | | | | | 0000 | |
| 12A0 | DCH3CON | 31:16 | CHPIGN<7:0> | | | | | | | — | — | — | — | — | — | — | — | 0000 | |
| | | 15:0 | CHBUSY | — | CHPIGNEN | — | CHPATLEN | — | — | CHCHNS | CHEN | CHAED | CHCHN | CHAEN | — | CHEDET | CHPRI<1:0> | 0000 | |
| 12B0 | DCH3ECON | 31:16 | — | — | — | — | — | — | — | CHAIRQ<7:0> | | | | | | | 00FF | | |
| | | 15:0 | CHSIRQ<7:0> | | | | | | | CFORCE | CABORT | PATEN | SIRQEN | AIRQEN | — | — | — | FF00 | |
| 12C0 | DCH3INT | 31:16 | — | — | — | — | — | — | — | CHSDIE | CHSHIE | CHDDIE | CHDHIE | CHBCIE | CHCCIE | CHTAIE | CHERIE | 0000 | |
| | | 15:0 | — | — | — | — | — | — | — | CHSDIF | CHSHIF | CHDDIF | CHDHIF | CHBCIF | CHCCIF | CHTAIF | CHERIF | 0000 | |
| 12D0 | DCH3SSA | 31:16 | CHSSA<31:0> | | | | | | | | | | | | | | | 0000 | |
| | | 15:0 | | | | | | | | | | | | | | | | 0000 | |
| 12E0 | DCH3DSA | 31:16 | CHDSA<31:0> | | | | | | | | | | | | | | | 0000 | |
| | | 15:0 | | | | | | | | | | | | | | | | 0000 | |
| 12F0 | DCH3SSIZ | 31:16 | — | — | — | — | — | — | — | — | — | — | — | — | — | — | — | 0000 | |
| | | 15:0 | CHSSIZ<15:0> | | | | | | | | | | | | | | | 0000 | |
| 1300 | DCH3DSIZ | 31:16 | — | — | — | — | — | — | — | — | — | — | — | — | — | — | — | 0000 | |
| | | 15:0 | CHDSIZ<15:0> | | | | | | | | | | | | | | | 0000 | |
| 1310 | DCH3SPTR | 31:16 | — | — | — | — | — | — | — | — | — | — | — | — | — | — | — | 0000 | |
| | | 15:0 | CHSPTR<15:0> | | | | | | | | | | | | | | | 0000 | |
| 1320 | DCH3DPTR | 31:16 | — | — | — | — | — | — | — | — | — | — | — | — | — | — | — | 0000 | |
| | | 15:0 | CHDPTR<15:0> | | | | | | | | | | | | | | | 0000 | |
| 1330 | DCH3CSIZ | 31:16 | — | — | — | — | — | — | — | — | — | — | — | — | — | — | — | 0000 | |
| | | 15:0 | CHCSIZ<15:0> | | | | | | | | | | | | | | | 0000 | |
| 1340 | DCH3CPTR | 31:16 | — | — | — | — | — | — | — | — | — | — | — | — | — | — | — | 0000 | |
| | | 15:0 | CHCPTR<15:0> | | | | | | | | | | | | | | | 0000 | |
| 1350 | DCH3DAT | 31:16 | — | — | — | — | — | — | — | — | — | — | — | — | — | — | — | 0000 | |
| | | 15:0 | CHPDAT<15:0> | | | | | | | | | | | | | | | 0000 | |
| 1360 | DCH4CON | 31:16 | CHPIGN<7:0> | | | | | | | — | — | — | — | — | — | — | — | 0000 | |
| | | 15:0 | CHBUSY | — | CHPIGNEN | — | CHPATLEN | — | — | CHCHNS | CHEN | CHAED | CHCHN | CHAEN | — | CHEDET | CHPRI<1:0> | 0000 | |
| 1370 | DCH4ECON | 31:16 | — | — | — | — | — | — | — | CHAIRQ<7:0> | | | | | | | 00FF | | |
| | | 15:0 | CHSIRQ<7:0> | | | | | | | CFORCE | CABORT | PATEN | SIRQEN | AIRQEN | — | — | — | FF00 | |
| 1380 | DCH4INT | 31:16 | — | — | — | — | — | — | — | CHSDIE | CHSHIE | CHDDIE | CHDHIE | CHBCIE | CHCCIE | CHTAIE | CHERIE | 0000 | |
| | | 15:0 | — | — | — | — | — | — | — | CHSDIF | CHSHIF | CHDDIF | CHDHIF | CHBCIF | CHCCIF | CHTAIF | CHERIF | 0000 | |

Legend: x = unknown value on Reset; — = unimplemented, read as '0'. Reset values are shown in hexadecimal.

Note 1: All registers in this table have corresponding CLR, SET and INV registers at their virtual addresses, plus offsets of 0x4, 0x8 and 0xC, respectively. See [Section 12.3 “CLR, SET, and INV Registers”](#) for more information.

TABLE 10-3: DMA CHANNEL 0 THROUGH CHANNEL 7 REGISTER MAP (CONTINUED)

| Virtual Address (BF81_#) | Register Name ⁽¹⁾ | Bit Range | Bits | | | | | | | | | | | | | | | | All Resets | |
|-----------------------------|---------------------------------|-----------|--------------|-------|----------|-------|----------|-------|------|------|--------|-------------|--------|--------|--------|--------|--------|------------|------------|------|
| | | | 31/15 | 30/14 | 29/13 | 28/12 | 27/11 | 26/10 | 25/9 | 24/8 | 23/7 | 22/6 | 21/5 | 20/4 | 19/3 | 18/2 | 17/1 | 16/0 | | |
| 1390 | DCH4SSA | 31:16 | CHSSA<31:0> | | | | | | | | | | | | | | | | 0000 | |
| | | 15:0 | | | | | | | | | | | | | | | | | 0000 | |
| 13A0 | DCH4DSA | 31:16 | CHDSA<31:0> | | | | | | | | | | | | | | | | 0000 | |
| | | 15:0 | | | | | | | | | | | | | | | | | 0000 | |
| 13B0 | DCH4SSIZ | 31:16 | — | — | — | — | — | — | — | — | — | — | — | — | — | — | — | — | 0000 | |
| | | 15:0 | CHSSIZ<15:0> | | | | | | | | | | | | | | | | 0000 | |
| 13C0 | DCH4DSIZ | 31:16 | — | — | — | — | — | — | — | — | — | — | — | — | — | — | — | — | 0000 | |
| | | 15:0 | CHDSIZ<15:0> | | | | | | | | | | | | | | | | 0000 | |
| 13D0 | DCH4SPTR | 31:16 | — | — | — | — | — | — | — | — | — | — | — | — | — | — | — | — | 0000 | |
| | | 15:0 | CHSPTR<15:0> | | | | | | | | | | | | | | | | 0000 | |
| 13E0 | DCH4DPTR | 31:16 | — | — | — | — | — | — | — | — | — | — | — | — | — | — | — | — | 0000 | |
| | | 15:0 | CHDPTR<15:0> | | | | | | | | | | | | | | | | 0000 | |
| 13F0 | DCH4CSIZ | 31:16 | — | — | — | — | — | — | — | — | — | — | — | — | — | — | — | — | 0000 | |
| | | 15:0 | CHCSIZ<15:0> | | | | | | | | | | | | | | | | 0000 | |
| 1400 | DCH4CPTR | 31:16 | — | — | — | — | — | — | — | — | — | — | — | — | — | — | — | — | 0000 | |
| | | 15:0 | CHCPTR<15:0> | | | | | | | | | | | | | | | | 0000 | |
| 1410 | DCH4DAT | 31:16 | — | — | — | — | — | — | — | — | — | — | — | — | — | — | — | — | 0000 | |
| | | 15:0 | CHPDAT<15:0> | | | | | | | | | | | | | | | | 0000 | |
| 1420 | DCH5CON | 31:16 | CHPIGN<7:0> | | | | | | | | | | | | | | | | 0000 | |
| | | 15:0 | CHBUSY | — | CHPIGNEN | — | CHPATLEN | — | — | — | CHCHNS | CHEN | CHAED | CHCHN | CHAEN | — | CHEDET | CHPRI<1:0> | 0000 | |
| 1430 | DCH5ECON | 31:16 | — | — | — | — | — | — | — | — | — | CHAIRQ<7:0> | | | | | | 00FF | | |
| | | 15:0 | CHSIRQ<7:0> | | | | | | | | CFORCE | CABORT | PATEN | SIRQEN | AIRQEN | — | — | — | FF00 | |
| 1440 | DCH5INT | 31:16 | — | — | — | — | — | — | — | — | — | CHSDIE | CHSHIE | CHDDIE | CHDHIE | CHBCIE | CHCCIE | CHTAIE | CHERIE | 0000 |
| | | 15:0 | — | — | — | — | — | — | — | — | — | CHSDIF | CHSHIF | CHDDIF | CHDHIF | CHBCIF | CHCCIF | CHTAIF | CHERIF | 0000 |
| 1450 | DCH5SSA | 31:16 | CHSSA<31:0> | | | | | | | | | | | | | | | | 0000 | |
| | | 15:0 | | | | | | | | | | | | | | | | | 0000 | |
| 1460 | DCH5DSA | 31:16 | CHDSA<31:0> | | | | | | | | | | | | | | | | 0000 | |
| | | 15:0 | | | | | | | | | | | | | | | | | 0000 | |
| 1470 | DCH5SSIZ | 31:16 | — | — | — | — | — | — | — | — | — | — | — | — | — | — | — | — | 0000 | |
| | | 15:0 | CHSSIZ<15:0> | | | | | | | | | | | | | | | | 0000 | |
| 1480 | DCH5DSIZ | 31:16 | — | — | — | — | — | — | — | — | — | — | — | — | — | — | — | — | 0000 | |
| | | 15:0 | CHDSIZ<15:0> | | | | | | | | | | | | | | | | 0000 | |
| 1490 | DCH5SPTR | 31:16 | — | — | — | — | — | — | — | — | — | — | — | — | — | — | — | — | 0000 | |
| | | 15:0 | CHSPTR<15:0> | | | | | | | | | | | | | | | | 0000 | |

Legend: x = unknown value on Reset; — = unimplemented, read as '0'. Reset values are shown in hexadecimal.

Note 1: All registers in this table have corresponding CLR, SET and INV registers at their virtual addresses, plus offsets of 0x4, 0x8 and 0xC, respectively. See [Section 12.3 “CLR, SET, and INV Registers”](#) for more information.

TABLE 10-3: DMA CHANNEL 0 THROUGH CHANNEL 7 REGISTER MAP (CONTINUED)

| Virtual Address (BF81_#) | Register Name ⁽¹⁾ | Bit Range | Bits | | | | | | | | | | | | | | | All Resets | |
|-----------------------------|---------------------------------|-----------|--------------|-------|----------|-------|----------|-------|------|--------|--------|--------|--------|--------|--------|--------|------------|------------|------|
| | | | 31/15 | 30/14 | 29/13 | 28/12 | 27/11 | 26/10 | 25/9 | 24/8 | 23/7 | 22/6 | 21/5 | 20/4 | 19/3 | 18/2 | 17/1 | | 16/0 |
| 14A0 | DCH5DPTR | 31:16 | — | — | — | — | — | — | — | — | — | — | — | — | — | — | — | — | 0000 |
| | | 15:0 | CHDPTR<15:0> | | | | | | | | | | | | | | | 0000 | |
| 14B0 | DCH5CSIZ | 31:16 | — | — | — | — | — | — | — | — | — | — | — | — | — | — | — | — | 0000 |
| | | 15:0 | CHCSIZ<15:0> | | | | | | | | | | | | | | | 0000 | |
| 14C0 | DCH5CPTR | 31:16 | — | — | — | — | — | — | — | — | — | — | — | — | — | — | — | — | 0000 |
| | | 15:0 | CHCPTR<15:0> | | | | | | | | | | | | | | | 0000 | |
| 14D0 | DCH5DAT | 31:16 | — | — | — | — | — | — | — | — | — | — | — | — | — | — | — | — | 0000 |
| | | 15:0 | CHPDAT<15:0> | | | | | | | | | | | | | | | 0000 | |
| 14E0 | DCH6CON | 31:16 | CHPIGN<7:0> | | | | | | | — | — | — | — | — | — | — | — | — | 0000 |
| | | 15:0 | CHBUSY | — | CHPIGNEN | — | CHPATLEN | — | — | CHCHNS | CHEN | CHAED | CHCHN | CHAEN | — | CHEDET | CHPRI<1:0> | 0000 | |
| 14F0 | DCH6ECON | 31:16 | CHAIRQ<7:0> | | | | | | | — | — | — | — | — | — | — | — | — | 00FF |
| | | 15:0 | CHSIRQ<7:0> | | | | | | | CFORCE | CABORT | PATEN | SIRQEN | AIRQEN | — | — | — | FF00 | |
| 1500 | DCH6INT | 31:16 | — | — | — | — | — | — | — | — | CHSDIE | CHSHIE | CHDDIE | CHDHIE | CHBCIE | CHCCIE | CHTAIE | CHERIE | 0000 |
| | | 15:0 | — | — | — | — | — | — | — | — | CHSDIF | CHSHIF | CHDDIF | CHDHIF | CHBCIF | CHCCIF | CHTAIF | CHERIF | 0000 |
| 1510 | DCH6SSA | 31:16 | CHSSA<31:0> | | | | | | | | | | | | | | | 0000 | |
| | | 15:0 | | | | | | | | | | | | | | | | 0000 | |
| 1520 | DCH6DSA | 31:16 | CHDSA<31:0> | | | | | | | | | | | | | | | 0000 | |
| | | 15:0 | | | | | | | | | | | | | | | | 0000 | |
| 1530 | DCH6SSIZ | 31:16 | — | — | — | — | — | — | — | — | — | — | — | — | — | — | — | — | 0000 |
| | | 15:0 | CHSSIZ<15:0> | | | | | | | | | | | | | | | 0000 | |
| 1540 | DCH6DSIZ | 31:16 | — | — | — | — | — | — | — | — | — | — | — | — | — | — | — | — | 0000 |
| | | 15:0 | CHDSIZ<15:0> | | | | | | | | | | | | | | | 0000 | |
| 1550 | DCH6SPTR | 31:16 | — | — | — | — | — | — | — | — | — | — | — | — | — | — | — | — | 0000 |
| | | 15:0 | CHSPTR<15:0> | | | | | | | | | | | | | | | 0000 | |
| 1560 | DCH6DPTR | 31:16 | — | — | — | — | — | — | — | — | — | — | — | — | — | — | — | — | 0000 |
| | | 15:0 | CHDPTR<15:0> | | | | | | | | | | | | | | | 0000 | |
| 1570 | DCH6CSIZ | 31:16 | — | — | — | — | — | — | — | — | — | — | — | — | — | — | — | — | 0000 |
| | | 15:0 | CHCSIZ<15:0> | | | | | | | | | | | | | | | 0000 | |
| 1580 | DCH6CPTR | 31:16 | — | — | — | — | — | — | — | — | — | — | — | — | — | — | — | — | 0000 |
| | | 15:0 | CHCPTR<15:0> | | | | | | | | | | | | | | | 0000 | |
| 1590 | DCH6DAT | 31:16 | — | — | — | — | — | — | — | — | — | — | — | — | — | — | — | — | 0000 |
| | | 15:0 | CHPDAT<15:0> | | | | | | | | | | | | | | | 0000 | |
| 15A0 | DCH7CON | 31:16 | CHPIGN<7:0> | | | | | | | — | — | — | — | — | — | — | — | — | 0000 |
| | | 15:0 | CHBUSY | — | CHPIGNEN | — | CHPATLEN | — | — | CHCHNS | CHEN | CHAED | CHCHN | CHAEN | — | CHEDET | CHPRI<1:0> | 0000 | |

Legend: x = unknown value on Reset; — = unimplemented, read as '0'. Reset values are shown in hexadecimal.

Note 1: All registers in this table have corresponding CLR, SET and INV registers at their virtual addresses, plus offsets of 0x4, 0x8 and 0xC, respectively. See [Section 12.3 “CLR, SET, and INV Registers”](#) for more information.

TABLE 10-3: DMA CHANNEL 0 THROUGH CHANNEL 7 REGISTER MAP (CONTINUED)

| Virtual Address (BF81_#) | Register Name ⁽¹⁾ | Bit Range | Bits | | | | | | | | | | | | | | | All Resets | | |
|-----------------------------|---------------------------------|-----------|--------------|-------|-------|-------|-------|-------|------|--------|--------|-------------|--------|--------|--------|--------|--------|------------|--------|------|
| | | | 31/15 | 30/14 | 29/13 | 28/12 | 27/11 | 26/10 | 25/9 | 24/8 | 23/7 | 22/6 | 21/5 | 20/4 | 19/3 | 18/2 | 17/1 | | 16/0 | |
| 15B0 | DCH7ECON | 31:16 | — | — | — | — | — | — | — | — | — | CHAIRQ<7:0> | | | | | | | 00FF | |
| | | 15:0 | CHSIRQ<7:0> | | | | | | | CFORCE | CABORT | PATEN | SIRQEN | AIRQEN | — | — | — | FF00 | | |
| 15C0 | DCH7INT | 31:16 | — | — | — | — | — | — | — | — | — | CHSDIE | CHSHIE | CHDDIE | CHDHIE | CHBCIE | CHCCIE | CHTAIE | CHERIE | 0000 |
| | | 15:0 | — | — | — | — | — | — | — | — | — | CHSDIF | CHSHIF | CHDDIF | CHDHIF | CHBCIF | CHCCIF | CHTAIF | CHERIF | 0000 |
| 15D0 | DCH7SSA | 31:16 | CHSSA<31:0> | | | | | | | | | | | | | | | 0000 | | |
| | | 15:0 | | | | | | | | | | | | | | | | 0000 | | |
| 15E0 | DCH7DSA | 31:16 | CHDSA<31:0> | | | | | | | | | | | | | | | 0000 | | |
| | | 15:0 | | | | | | | | | | | | | | | | 0000 | | |
| 15F0 | DCH7SSIZ | 31:16 | — | — | — | — | — | — | — | — | — | — | — | — | — | — | — | — | — | 0000 |
| | | 15:0 | CHSSIZ<15:0> | | | | | | | | | | | | | | | 0000 | | |
| 1600 | DCH7DSIZ | 31:16 | — | — | — | — | — | — | — | — | — | — | — | — | — | — | — | — | — | 0000 |
| | | 15:0 | CHDSIZ<15:0> | | | | | | | | | | | | | | | 0000 | | |
| 1610 | DCH7SPTR | 31:16 | — | — | — | — | — | — | — | — | — | — | — | — | — | — | — | — | — | 0000 |
| | | 15:0 | CHSPTR<15:0> | | | | | | | | | | | | | | | 0000 | | |
| 1620 | DCH7DPTR | 31:16 | — | — | — | — | — | — | — | — | — | — | — | — | — | — | — | — | — | 0000 |
| | | 15:0 | CHDPTR<15:0> | | | | | | | | | | | | | | | 0000 | | |
| 1630 | DCH7CSIZ | 31:16 | — | — | — | — | — | — | — | — | — | — | — | — | — | — | — | — | — | 0000 |
| | | 15:0 | CHCSIZ<15:0> | | | | | | | | | | | | | | | 0000 | | |
| 1640 | DCH7CPTR | 31:16 | — | — | — | — | — | — | — | — | — | — | — | — | — | — | — | — | — | 0000 |
| | | 15:0 | CHCPTR<15:0> | | | | | | | | | | | | | | | 0000 | | |
| 1650 | DCH7DAT | 31:16 | — | — | — | — | — | — | — | — | — | — | — | — | — | — | — | — | — | 0000 |
| | | 15:0 | CHPDAT<15:0> | | | | | | | | | | | | | | | 0000 | | |

Legend: x = unknown value on Reset; — = unimplemented, read as '0'. Reset values are shown in hexadecimal.

Note 1: All registers in this table have corresponding CLR, SET and INV registers at their virtual addresses, plus offsets of 0x4, 0x8 and 0xC, respectively. See [Section 12.3 “CLR, SET, and INV Registers”](#) for more information.

PIC32MZ Embedded Connectivity with Floating Point Unit (EF) Family

REGISTER 10-1: DMACON: DMA CONTROLLER CONTROL REGISTER

| Bit Range | Bit 31/23/15/7 | Bit 30/22/14/6 | Bit 29/21/13/5 | Bit 28/20/12/4 | Bit 27/19/11/3 | Bit 26/18/10/2 | Bit 25/17/9/1 | Bit 24/16/8/0 |
|-----------|----------------|----------------|----------------|----------------|----------------|----------------|---------------|---------------|
| 31:24 | U-0 | U-0 | U-0 | U-0 | U-0 | U-0 | U-0 | U-0 |
| | — | — | — | — | — | — | — | — |
| 23:16 | U-0 | U-0 | U-0 | U-0 | U-0 | U-0 | U-0 | U-0 |
| | — | — | — | — | — | — | — | — |
| 15:8 | R/W-0 | U-0 | U-0 | R/W-0 | R/W-0 | U-0 | U-0 | U-0 |
| | ON | — | — | SUSPEND | DMABUSY | — | — | — |
| 7:0 | U-0 | U-0 | U-0 | U-0 | U-0 | U-0 | U-0 | U-0 |
| | — | — | — | — | — | — | — | — |

Legend:

R = Readable bit
-n = Value at POR

W = Writable bit
'1' = Bit is set

U = Unimplemented bit, read as '0'
'0' = Bit is cleared
x = Bit is unknown

bit 31-16 **Unimplemented:** Read as '0'

bit 15 **ON:** DMA On bit

1 = DMA module is enabled
0 = DMA module is disabled

bit 14-13 **Unimplemented:** Read as '0'

bit 12 **SUSPEND:** DMA Suspend bit

1 = DMA transfers are suspended to allow CPU uninterrupted access to data bus
0 = DMA operates normally

bit 11 **DMABUSY:** DMA Module Busy bit

1 = DMA module is active and is transferring data
0 = DMA module is disabled and not actively transferring data

bit 10-0 **Unimplemented:** Read as '0'

PIC32MZ Embedded Connectivity with Floating Point Unit (EF) Family

REGISTER 10-4: DCRCCON: DMA CRC CONTROL REGISTER

| Bit Range | Bit 31/23/15/7 | Bit 30/22/14/6 | Bit 29/21/13/5 | Bit 28/20/12/4 | Bit 27/19/11/3 | Bit 26/18/10/2 | Bit 25/17/9/1 | Bit 24/16/8/0 |
|-----------|----------------|-----------------------|----------------|----------------|--------------------|----------------|---------------|---------------|
| 31:24 | U-0 | U-0 | R/W-0 | R/W-0 | R/W-0 | U-0 | U-0 | R/W-0 |
| | — | — | BYTO<1:0> | | WBO ⁽¹⁾ | — | — | BITO |
| 23:16 | U-0 | U-0 | U-0 | U-0 | U-0 | U-0 | U-0 | U-0 |
| | — | — | — | — | — | — | — | — |
| 15:8 | U-0 | U-0 | U-0 | R/W-0 | R/W-0 | R/W-0 | R/W-0 | R/W-0 |
| | — | — | — | PLEN<4:0> | | | | |
| 7:0 | R/W-0 | R/W-0 | R/W-0 | U-0 | U-0 | R/W-0 | R/W-0 | R/W-0 |
| | CRCEN | CRCAPP ⁽¹⁾ | CRCTYP | — | — | CRCCH<2:0> | | |

Legend:

R = Readable bit
-n = Value at POR

W = Writable bit
'1' = Bit is set

U = Unimplemented bit, read as '0'
'0' = Bit is cleared
x = Bit is unknown

bit 31-30 **Unimplemented:** Read as '0'

bit 29-28 **BYTO<1:0>:** CRC Byte Order Selection bits

11 = Endian byte swap on half-word boundaries (i.e., source half-word order with reverse source byte order per half-word)

10 = Swap half-words on word boundaries (i.e., reverse source half-word order with source byte order per half-word)

01 = Endian byte swap on word boundaries (i.e., reverse source byte order)

00 = No swapping (i.e., source byte order)

bit 27 **WBO:** CRC Write Byte Order Selection bit⁽¹⁾

1 = Source data is written to the destination re-ordered as defined by BYTO<1:0>

0 = Source data is written to the destination unaltered

bit 26-25 **Unimplemented:** Read as '0'

bit 24 **BITO:** CRC Bit Order Selection bit

When CRCTYP (DCRCCON<15>) = 1 (CRC module is in IP Header mode):

1 = The IP header checksum is calculated Least Significant bit (LSb) first (i.e., reflected)

0 = The IP header checksum is calculated Most Significant bit (MSb) first (i.e., not reflected)

When CRCTYP (DCRCCON<15>) = 0 (CRC module is in LFSR mode):

1 = The LFSR CRC is calculated Least Significant bit first (i.e., reflected)

0 = The LFSR CRC is calculated Most Significant bit first (i.e., not reflected)

bit 23-13 **Unimplemented:** Read as '0'

bit 12-8 **PLEN<4:0>:** Polynomial Length bits⁽¹⁾

When CRCTYP (DCRCCON<15>) = 1 (CRC module is in IP Header mode):

These bits are unused.

When CRCTYP (DCRCCON<15>) = 0 (CRC module is in LFSR mode):

Denotes the length of the polynomial – 1.

bit 7 **CRCEN:** CRC Enable bit

1 = CRC module is enabled and channel transfers are routed through the CRC module

0 = CRC module is disabled and channel transfers proceed normally

Note 1: When WBO = 1, unaligned transfers are not supported and the CRCAPP bit cannot be set.

PIC32MZ Embedded Connectivity with Floating Point Unit (EF) Family

REGISTER 10-4: DCRCCON: DMA CRC CONTROL REGISTER (CONTINUED)

- bit 6 **CRCAPP:** CRC Append Mode bit⁽¹⁾
1 = The DMA transfers data from the source into the CRC but NOT to the destination. When a block transfer completes the DMA writes the calculated CRC value to the location given by CHxDSA
0 = The DMA transfers data from the source through the CRC obeying WBO as it writes the data to the destination
- bit 5 **CRCTYP:** CRC Type Selection bit
1 = The CRC module will calculate an IP header checksum
0 = The CRC module will calculate a LFSR CRC
- bit 4-3 **Unimplemented:** Read as '0'
- bit 2-0 **CRCCH<2:0>:** CRC Channel Select bits
111 = CRC is assigned to Channel 7
110 = CRC is assigned to Channel 6
101 = CRC is assigned to Channel 5
100 = CRC is assigned to Channel 4
011 = CRC is assigned to Channel 3
010 = CRC is assigned to Channel 2
001 = CRC is assigned to Channel 1
000 = CRC is assigned to Channel 0

Note 1: When WBO = 1, unaligned transfers are not supported and the CRCAPP bit cannot be set.

PIC32MZ Embedded Connectivity with Floating Point Unit (EF) Family

REGISTER 10-5: DCRCDATA: DMA CRC DATA REGISTER

| Bit Range | Bit 31/23/15/7 | Bit 30/22/14/6 | Bit 29/21/13/5 | Bit 28/20/12/4 | Bit 27/19/11/3 | Bit 26/18/10/2 | Bit 25/17/9/1 | Bit 24/16/8/0 |
|-----------------|----------------|----------------|----------------|----------------|----------------|----------------|---------------|---------------|
| 31:24 | R/W-0 | R/W-0 | R/W-0 | R/W-0 | R/W-0 | R/W-0 | R/W-0 | R/W-0 |
| DCRCDATA<31:24> | | | | | | | | |
| 23:16 | R/W-0 | R/W-0 | R/W-0 | R/W-0 | R/W-0 | R/W-0 | R/W-0 | R/W-0 |
| DCRCDATA<23:16> | | | | | | | | |
| 15:8 | R/W-0 | R/W-0 | R/W-0 | R/W-0 | R/W-0 | R/W-0 | R/W-0 | R/W-0 |
| DCRCDATA<15:8> | | | | | | | | |
| 7:0 | R/W-0 | R/W-0 | R/W-0 | R/W-0 | R/W-0 | R/W-0 | R/W-0 | R/W-0 |
| DCRCDATA<7:0> | | | | | | | | |

Legend:

R = Readable bit W = Writable bit U = Unimplemented bit, read as '0'
 -n = Value at POR '1' = Bit is set '0' = Bit is cleared x = Bit is unknown

bit 31-0 **DCRCDATA<31:0>**: CRC Data Register bits

Writing to this register will seed the CRC generator. Reading from this register will return the current value of the CRC. Bits greater than PLEN will return '0' on any read.

When CRCTYP (DCRCCON<15>) = 1 (CRC module is in IP Header mode):

Only the lower 16 bits contain IP header checksum information. The upper 16 bits are always '0'. Data written to this register is converted and read back in 1's complement form (i.e., current IP header checksum value).

When CRCTYP (DCRCCON<15>) = 0 (CRC module is in LFSR mode):

Bits greater than PLEN will return '0' on any read.

REGISTER 10-6: DCRCXOR: DMA CRCXOR ENABLE REGISTER

| Bit Range | Bit 31/23/15/7 | Bit 30/22/14/6 | Bit 29/21/13/5 | Bit 28/20/12/4 | Bit 27/19/11/3 | Bit 26/18/10/2 | Bit 25/17/9/1 | Bit 24/16/8/0 |
|----------------|----------------|----------------|----------------|----------------|----------------|----------------|---------------|---------------|
| 31:24 | R/W-0 | R/W-0 | R/W-0 | R/W-0 | R/W-0 | R/W-0 | R/W-0 | R/W-0 |
| DCRCXOR<31:24> | | | | | | | | |
| 23:16 | R/W-0 | R/W-0 | R/W-0 | R/W-0 | R/W-0 | R/W-0 | R/W-0 | R/W-0 |
| DCRCXOR<23:16> | | | | | | | | |
| 15:8 | R/W-0 | R/W-0 | R/W-0 | R/W-0 | R/W-0 | R/W-0 | R/W-0 | R/W-0 |
| DCRCXOR<15:8> | | | | | | | | |
| 7:0 | R/W-0 | R/W-0 | R/W-0 | R/W-0 | R/W-0 | R/W-0 | R/W-0 | R/W-0 |
| DCRCXOR<7:0> | | | | | | | | |

Legend:

R = Readable bit W = Writable bit U = Unimplemented bit, read as '0'
 -n = Value at POR '1' = Bit is set '0' = Bit is cleared x = Bit is unknown

bit 31-0 **DCRCXOR<31:0>**: CRC XOR Register bits

When CRCTYP (DCRCCON<15>) = 1 (CRC module is in IP Header mode):

This register is unused.

When CRCTYP (DCRCCON<15>) = 0 (CRC module is in LFSR mode):

1 = Enable the XOR input to the Shift register

0 = Disable the XOR input to the Shift register; data is shifted in directly from the previous stage in the register

PIC32MZ Embedded Connectivity with Floating Point Unit (EF) Family

REGISTER 10-7: DCHxCON: DMA CHANNEL x CONTROL REGISTER

| Bit Range | Bit 31/23/15/7 | Bit 30/22/14/6 | Bit 29/21/13/5 | Bit 28/20/12/4 | Bit 27/19/11/3 | Bit 26/18/10/2 | Bit 25/17/9/1 | Bit 24/16/8/0 | | | | | | | | | |
|--|---------------------|----------------|----------------|----------------|----------------|----------------|---------------|-----------------------|--|---------------------|-------|----------|-------|----------|--------|------------|-----------------------|
| 31:24 | R/W-0 | R/W-0 | R/W-0 | R/W-0 | R/W-0 | R/W-0 | R/W-0 | R/W-0 | | | | | | | | | |
| CHPIGN<7:0> | | | | | | | | | | | | | | | | | |
| 23:16 | U-0 | U-0 | U-0 | U-0 | U-0 | U-0 | U-0 | U-0 | | | | | | | | | |
| — | | | | | | | | | | | | | | | | | |
| 15:8 | R/W-0 | U-0 | R/W-0 | U-0 | R/W-0 | U-0 | U-0 | R/W-0 | | | | | | | | | |
| <table border="0" style="width: 100%; border-collapse: collapse;"> <tr> <td style="width: 12.5%;"></td> <td style="width: 12.5%;">CHBUSY</td> <td style="width: 12.5%;">—</td> <td style="width: 12.5%;">CHIPGNEN</td> <td style="width: 12.5%;">—</td> <td style="width: 12.5%;">CHPATLEN</td> <td style="width: 12.5%;">—</td> <td style="width: 12.5%;">—</td> <td style="width: 12.5%;">CHCHNS⁽¹⁾</td> </tr> </table> | | | | | | | | | | CHBUSY | — | CHIPGNEN | — | CHPATLEN | — | — | CHCHNS ⁽¹⁾ |
| | CHBUSY | — | CHIPGNEN | — | CHPATLEN | — | — | CHCHNS ⁽¹⁾ | | | | | | | | | |
| 7:0 | R/W-0 | R/W-0 | R/W-0 | R/W-0 | U-0 | R-0 | R/W-0 | R/W-0 | | | | | | | | | |
| <table border="0" style="width: 100%; border-collapse: collapse;"> <tr> <td style="width: 12.5%;"></td> <td style="width: 12.5%;">CHEN⁽²⁾</td> <td style="width: 12.5%;">CHAED</td> <td style="width: 12.5%;">CHCHN</td> <td style="width: 12.5%;">CHAEN</td> <td style="width: 12.5%;">—</td> <td style="width: 12.5%;">CHEDET</td> <td colspan="2" style="width: 12.5%;">CHPRI<1:0></td> </tr> </table> | | | | | | | | | | CHEN ⁽²⁾ | CHAED | CHCHN | CHAEN | — | CHEDET | CHPRI<1:0> | |
| | CHEN ⁽²⁾ | CHAED | CHCHN | CHAEN | — | CHEDET | CHPRI<1:0> | | | | | | | | | | |

Legend:

| | | |
|-------------------|------------------|--|
| R = Readable bit | W = Writable bit | U = Unimplemented bit, read as '0' |
| -n = Value at POR | '1' = Bit is set | '0' = Bit is cleared x = Bit is unknown |

bit 31-24 **CHPIGN<7:0>**: Channel Register Data bits

Pattern Terminate mode:

Any byte matching these bits during a pattern match may be ignored during the pattern match determination when the CHIPGNEN bit is set. If a byte is read that is identical to this data byte, the pattern match logic will treat it as a "don't care" when the pattern matching logic is enabled and the CHPIGEN bit is set.

bit 23-16 **Unimplemented**: Read as '0'

bit 15 **CHBUSY**: Channel Busy bit

1 = Channel is active or has been enabled
0 = Channel is inactive or has been disabled

bit 14 **Unimplemented**: Read as '0'

bit 13 **CHIPGNEN**: Enable Pattern Ignore Byte bit

1 = Treat any byte that matches the CHPIGN<7:0> bits as a "don't care" when pattern matching is enabled
0 = Disable this feature

bit 12 **Unimplemented**: Read as '0'

bit 11 **CHPATLEN**: Pattern Length bit

1 = 2 byte length
0 = 1 byte length

bit 10-9 **Unimplemented**: Read as '0'

bit 8 **CHCHNS**: Chain Channel Selection bit⁽¹⁾

1 = Chain to channel lower in natural priority (CH1 will be enabled by CH2 transfer complete)
0 = Chain to channel higher in natural priority (CH1 will be enabled by CH0 transfer complete)

bit 7 **CHEN**: Channel Enable bit⁽²⁾

1 = Channel is enabled
0 = Channel is disabled

bit 6 **CHAED**: Channel Allow Events If Disabled bit

1 = Channel start/abort events will be registered, even if the channel is disabled
0 = Channel start/abort events will be ignored if the channel is disabled

bit 5 **CHCHN**: Channel Chain Enable bit

1 = Allow channel to be chained
0 = Do not allow channel to be chained

Note 1: The chain selection bit takes effect when chaining is enabled (i.e., CHCHN = 1).

Note 2: When the channel is suspended by clearing this bit, the user application should poll the CHBUSY bit (if available on the device variant) to see when the channel is suspended, as it may take some clock cycles to complete a current transaction before the channel is suspended.

PIC32MZ Embedded Connectivity with Floating Point Unit (EF) Family

REGISTER 10-7: DCHxCON: DMA CHANNEL x CONTROL REGISTER (CONTINUED)

- bit 4 **CHAEN:** Channel Automatic Enable bit
 1 = Channel is continuously enabled, and not automatically disabled after a block transfer is complete
 0 = Channel is disabled on block transfer complete
- bit 3 **Unimplemented:** Read as '0'
- bit 2 **CHEDET:** Channel Event Detected bit
 1 = An event has been detected
 0 = No events have been detected
- bit 1-0 **CHPRI<1:0>:** Channel Priority bits
 11 = Channel has priority 3 (highest)
 10 = Channel has priority 2
 01 = Channel has priority 1
 00 = Channel has priority 0

- Note 1:** The chain selection bit takes effect when chaining is enabled (i.e., CHCHN = 1).
- 2:** When the channel is suspended by clearing this bit, the user application should poll the CHBUSY bit (if available on the device variant) to see when the channel is suspended, as it may take some clock cycles to complete a current transaction before the channel is suspended.

PIC32MZ Embedded Connectivity with Floating Point Unit (EF) Family

REGISTER 10-8: DCHxECON: DMA CHANNEL x EVENT CONTROL REGISTER

| Bit Range | Bit 31/23/15/7 | Bit 30/22/14/6 | Bit 29/21/13/5 | Bit 28/20/12/4 | Bit 27/19/11/3 | Bit 26/18/10/2 | Bit 25/17/9/1 | Bit 24/16/8/0 |
|-----------|----------------------------|----------------|----------------|----------------|----------------|----------------|---------------|---------------|
| 31:24 | U-0 | U-0 | U-0 | U-0 | U-0 | U-0 | U-0 | U-0 |
| | — | — | — | — | — | — | — | — |
| 23:16 | R/W-1 | R/W-1 | R/W-1 | R/W-1 | R/W-1 | R/W-1 | R/W-1 | R/W-1 |
| | CHAIRQ<7:0> ⁽¹⁾ | | | | | | | |
| 15:8 | R/W-1 | R/W-1 | R/W-1 | R/W-1 | R/W-1 | R/W-1 | R/W-1 | R/W-1 |
| | CHSIRQ<7:0> ⁽¹⁾ | | | | | | | |
| 7:0 | S-0 | S-0 | R/W-0 | R/W-0 | R/W-0 | U-0 | U-0 | U-0 |
| | CFORCE | CABORT | PATEN | SIRQEN | AIRQEN | — | — | — |

| | |
|-------------------|------------------------------------|
| Legend: | S = Settable bit |
| R = Readable bit | W = Writable bit |
| -n = Value at POR | '1' = Bit is set |
| | U = Unimplemented bit, read as '0' |
| | '0' = Bit is cleared |
| | x = Bit is unknown |

bit 31-24 **Unimplemented:** Read as '0'

bit 23-16 **CHAIRQ<7:0>**: Channel Transfer Abort IRQ bits⁽¹⁾

11111111 = Interrupt 255 will abort any transfers in progress and set CHAIF flag

•
•
•

00000001 = Interrupt 1 will abort any transfers in progress and set CHAIF flag

00000000 = Interrupt 0 will abort any transfers in progress and set CHAIF flag

bit 15-8 **CHSIRQ<7:0>**: Channel Transfer Start IRQ bits⁽¹⁾

11111111 = Interrupt 255 will initiate a DMA transfer

•
•
•

00000001 = Interrupt 1 will initiate a DMA transfer

00000000 = Interrupt 0 will initiate a DMA transfer

bit 7 **CFORCE**: DMA Forced Transfer bit

1 = A DMA transfer is forced to begin when this bit is written to a '1'

0 = This bit always reads '0'

bit 6 **CABORT**: DMA Abort Transfer bit

1 = A DMA transfer is aborted when this bit is written to a '1'

0 = This bit always reads '0'

bit 5 **PATEN**: Channel Pattern Match Abort Enable bit

1 = Abort transfer and clear CHEN on pattern match

0 = Pattern match is disabled

bit 4 **SIRQEN**: Channel Start IRQ Enable bit

1 = Start channel cell transfer if an interrupt matching CHSIRQ occurs

0 = Interrupt number CHSIRQ is ignored and does not start a transfer

bit 3 **AIRQEN**: Channel Abort IRQ Enable bit

1 = Channel transfer is aborted if an interrupt matching CHAIRQ occurs

0 = Interrupt number CHAIRQ is ignored and does not terminate a transfer

bit 2-0 **Unimplemented:** Read as '0'

Note 1: See [Table 7-2: "Interrupt IRQ, Vector, and Bit Location"](#) for the list of available interrupt IRQ sources.

PIC32MZ Embedded Connectivity with Floating Point Unit (EF) Family

REGISTER 10-9: DCHxINT: DMA CHANNEL x INTERRUPT CONTROL REGISTER

| Bit Range | Bit 31/23/15/7 | Bit 30/22/14/6 | Bit 29/21/13/5 | Bit 28/20/12/4 | Bit 27/19/11/3 | Bit 26/18/10/2 | Bit 25/17/9/1 | Bit 24/16/8/0 |
|-----------|----------------|----------------|----------------|----------------|----------------|----------------|---------------|---------------|
| 31:24 | U-0 | U-0 | U-0 | U-0 | U-0 | U-0 | U-0 | U-0 |
| | — | — | — | — | — | — | — | — |
| 23:16 | R/W-0 | R/W-0 | R/W-0 | R/W-0 | R/W-0 | R/W-0 | R/W-0 | R/W-0 |
| | CHSDIE | CHSHIE | CHDDIE | CHDHIE | CHBCIE | CHCCIE | CHTAIE | CHERIE |
| 15:8 | U-0 | U-0 | U-0 | U-0 | U-0 | U-0 | U-0 | U-0 |
| | — | — | — | — | — | — | — | — |
| 7:0 | R/W-0 | R/W-0 | R/W-0 | R/W-0 | R/W-0 | R/W-0 | R/W-0 | R/W-0 |
| | CHSDIF | CHSHIF | CHDDIF | CHDHIF | CHBCIF | CHCCIF | CHTAIF | CHERIF |

Legend:

R = Readable bit
-n = Value at POR

W = Writable bit
'1' = Bit is set

U = Unimplemented bit, read as '0'
'0' = Bit is cleared
x = Bit is unknown

- bit 31-24 **Unimplemented:** Read as '0'
- bit 23 **CHSDIE:** Channel Source Done Interrupt Enable bit
 - 1 = Interrupt is enabled
 - 0 = Interrupt is disabled
- bit 22 **CHSHIE:** Channel Source Half Empty Interrupt Enable bit
 - 1 = Interrupt is enabled
 - 0 = Interrupt is disabled
- bit 21 **CHDDIE:** Channel Destination Done Interrupt Enable bit
 - 1 = Interrupt is enabled
 - 0 = Interrupt is disabled
- bit 20 **CHDHIE:** Channel Destination Half Full Interrupt Enable bit
 - 1 = Interrupt is enabled
 - 0 = Interrupt is disabled
- bit 19 **CHBCIE:** Channel Block Transfer Complete Interrupt Enable bit
 - 1 = Interrupt is enabled
 - 0 = Interrupt is disabled
- bit 18 **CHCCIE:** Channel Cell Transfer Complete Interrupt Enable bit
 - 1 = Interrupt is enabled
 - 0 = Interrupt is disabled
- bit 17 **CHTAIE:** Channel Transfer Abort Interrupt Enable bit
 - 1 = Interrupt is enabled
 - 0 = Interrupt is disabled
- bit 16 **CHERIE:** Channel Address Error Interrupt Enable bit
 - 1 = Interrupt is enabled
 - 0 = Interrupt is disabled
- bit 15-8 **Unimplemented:** Read as '0'
- bit 7 **CHSDIF:** Channel Source Done Interrupt Flag bit
 - 1 = Channel Source Pointer has reached end of source (CHSPTR = CHSSIZ)
 - 0 = No interrupt is pending
- bit 6 **CHSHIF:** Channel Source Half Empty Interrupt Flag bit
 - 1 = Channel Source Pointer has reached midpoint of source (CHSPTR = CHSSIZ/2)
 - 0 = No interrupt is pending

PIC32MZ Embedded Connectivity with Floating Point Unit (EF) Family

REGISTER 10-9: DCHxINT: DMA CHANNEL x INTERRUPT CONTROL REGISTER (CONTINUED)

- bit 5 **CHDDIF**: Channel Destination Done Interrupt Flag bit
 1 = Channel Destination Pointer has reached end of destination (CHDPTR = CHDSIZ)
 0 = No interrupt is pending
- bit 4 **CHDHIF**: Channel Destination Half Full Interrupt Flag bit
 1 = Channel Destination Pointer has reached midpoint of destination (CHDPTR = CHDSIZ/2)
 0 = No interrupt is pending
- bit 3 **CHBCIF**: Channel Block Transfer Complete Interrupt Flag bit
 1 = A block transfer has been completed (the larger of CHSSIZ/CHDSIZ bytes has been transferred), or a
 pattern match event occurs
 0 = No interrupt is pending
- bit 2 **CHCCIF**: Channel Cell Transfer Complete Interrupt Flag bit
 1 = A cell transfer has been completed (CHCSIZ bytes have been transferred)
 0 = No interrupt is pending
- bit 1 **CHTAIF**: Channel Transfer Abort Interrupt Flag bit
 1 = An interrupt matching CHAIRQ has been detected and the DMA transfer has been aborted
 0 = No interrupt is pending
- bit 0 **CHERIF**: Channel Address Error Interrupt Flag bit
 1 = A channel address error has been detected
 Either the source or the destination address is invalid.
 0 = No interrupt is pending

PIC32MZ Embedded Connectivity with Floating Point Unit (EF) Family

REGISTER 10-10: DCHxSSA: DMA CHANNEL x SOURCE START ADDRESS REGISTER

| Bit Range | Bit 31/23/15/7 | Bit 30/22/14/6 | Bit 29/21/13/5 | Bit 28/20/12/4 | Bit 27/19/11/3 | Bit 26/18/10/2 | Bit 25/17/9/1 | Bit 24/16/8/0 |
|-----------|----------------|----------------|----------------|----------------|----------------|----------------|---------------|---------------|
| 31:24 | R/W-0 | R/W-0 | R/W-0 | R/W-0 | R/W-0 | R/W-0 | R/W-0 | R/W-0 |
| | CHSSA<31:24> | | | | | | | |
| 23:16 | R/W-0 | R/W-0 | R/W-0 | R/W-0 | R/W-0 | R/W-0 | R/W-0 | R/W-0 |
| | CHSSA<23:16> | | | | | | | |
| 15:8 | R/W-0 | R/W-0 | R/W-0 | R/W-0 | R/W-0 | R/W-0 | R/W-0 | R/W-0 |
| | CHSSA<15:8> | | | | | | | |
| 7:0 | R/W-0 | R/W-0 | R/W-0 | R/W-0 | R/W-0 | R/W-0 | R/W-0 | R/W-0 |
| | CHSSA<7:0> | | | | | | | |

Legend:

R = Readable bit
-n = Value at POR

W = Writable bit
'1' = Bit is set

U = Unimplemented bit, read as '0'
'0' = Bit is cleared
x = Bit is unknown

bit 31-0 **CHSSA<31:0>**: Channel Source Start Address bits
Channel source start address.

Note: This must be the physical address of the source.

REGISTER 10-11: DCHxDSEA: DMA CHANNEL x DESTINATION START ADDRESS REGISTER

| Bit Range | Bit 31/23/15/7 | Bit 30/22/14/6 | Bit 29/21/13/5 | Bit 28/20/12/4 | Bit 27/19/11/3 | Bit 26/18/10/2 | Bit 25/17/9/1 | Bit 24/16/8/0 |
|-----------|----------------|----------------|----------------|----------------|----------------|----------------|---------------|---------------|
| 31:24 | R/W-0 | R/W-0 | R/W-0 | R/W-0 | R/W-0 | R/W-0 | R/W-0 | R/W-0 |
| | CHDSA<31:24> | | | | | | | |
| 23:16 | R/W-0 | R/W-0 | R/W-0 | R/W-0 | R/W-0 | R/W-0 | R/W-0 | R/W-0 |
| | CHDSA<23:16> | | | | | | | |
| 15:8 | R/W-0 | R/W-0 | R/W-0 | R/W-0 | R/W-0 | R/W-0 | R/W-0 | R/W-0 |
| | CHDSA<15:8> | | | | | | | |
| 7:0 | R/W-0 | R/W-0 | R/W-0 | R/W-0 | R/W-0 | R/W-0 | R/W-0 | R/W-0 |
| | CHDSA<7:0> | | | | | | | |

Legend:

R = Readable bit
-n = Value at POR

W = Writable bit
'1' = Bit is set

U = Unimplemented bit, read as '0'
'0' = Bit is cleared
x = Bit is unknown

bit 31-0 **CHDSA<31:0>**: Channel Destination Start Address bits
Channel destination start address.

Note: This must be the physical address of the destination.

PIC32MZ Embedded Connectivity with Floating Point Unit (EF) Family

REGISTER 10-14: DCHxSPTR: DMA CHANNEL x SOURCE POINTER REGISTER

| Bit Range | Bit 31/23/15/7 | Bit 30/22/14/6 | Bit 29/21/13/5 | Bit 28/20/12/4 | Bit 27/19/11/3 | Bit 26/18/10/2 | Bit 25/17/9/1 | Bit 24/16/8/0 |
|-----------|----------------|----------------|----------------|----------------|----------------|----------------|---------------|---------------|
| 31:24 | U-0 | U-0 | U-0 | U-0 | U-0 | U-0 | U-0 | U-0 |
| | — | — | — | — | — | — | — | — |
| 23:16 | U-0 | U-0 | U-0 | U-0 | U-0 | U-0 | U-0 | U-0 |
| | — | — | — | — | — | — | — | — |
| 15:8 | R-0 | R-0 | R-0 | R-0 | R-0 | R-0 | R-0 | R-0 |
| | CHSPTR<15:8> | | | | | | | |
| 7:0 | R-0 | R-0 | R-0 | R-0 | R-0 | R-0 | R-0 | R-0 |
| | CHSPTR<7:0> | | | | | | | |

Legend:

R = Readable bit W = Writable bit U = Unimplemented bit, read as '0'
 -n = Value at POR '1' = Bit is set '0' = Bit is cleared x = Bit is unknown

bit 31-16 **Unimplemented:** Read as '0'

bit 15-0 **CHSPTR<15:0>:** Channel Source Pointer bits

1111111111111111 = Points to byte 65,535 of the source

•
•
•

0000000000000001 = Points to byte 1 of the source

0000000000000000 = Points to byte 0 of the source

Note: When in Pattern Detect mode, this register is reset on a pattern detect.

REGISTER 10-15: DCHxDPTR: DMA CHANNEL x DESTINATION POINTER REGISTER

| Bit Range | Bit 31/23/15/7 | Bit 30/22/14/6 | Bit 29/21/13/5 | Bit 28/20/12/4 | Bit 27/19/11/3 | Bit 26/18/10/2 | Bit 25/17/9/1 | Bit 24/16/8/0 |
|-----------|----------------|----------------|----------------|----------------|----------------|----------------|---------------|---------------|
| 31:24 | U-0 | U-0 | U-0 | U-0 | U-0 | U-0 | U-0 | U-0 |
| | — | — | — | — | — | — | — | — |
| 23:16 | U-0 | U-0 | U-0 | U-0 | U-0 | U-0 | U-0 | U-0 |
| | — | — | — | — | — | — | — | — |
| 15:8 | R-0 | R-0 | R-0 | R-0 | R-0 | R-0 | R-0 | R-0 |
| | CHDPTR<15:8> | | | | | | | |
| 7:0 | R-0 | R-0 | R-0 | R-0 | R-0 | R-0 | R-0 | R-0 |
| | CHDPTR<7:0> | | | | | | | |

Legend:

R = Readable bit W = Writable bit U = Unimplemented bit, read as '0'
 -n = Value at POR '1' = Bit is set '0' = Bit is cleared x = Bit is unknown

bit 31-16 **Unimplemented:** Read as '0'

bit 15-0 **CHDPTR<15:0>:** Channel Destination Pointer bits

1111111111111111 = Points to byte 65,535 of the destination

•
•
•

0000000000000001 = Points to byte 1 of the destination

0000000000000000 = Points to byte 0 of the destination

PIC32MZ Embedded Connectivity with Floating Point Unit (EF) Family

REGISTER 10-16: DCHxCSIZ: DMA CHANNEL x CELL-SIZE REGISTER

| Bit Range | Bit 31/23/15/7 | Bit 30/22/14/6 | Bit 29/21/13/5 | Bit 28/20/12/4 | Bit 27/19/11/3 | Bit 26/18/10/2 | Bit 25/17/9/1 | Bit 24/16/8/0 |
|-----------|----------------|----------------|----------------|----------------|----------------|----------------|---------------|---------------|
| 31:24 | U-0 | U-0 | U-0 | U-0 | U-0 | U-0 | U-0 | U-0 |
| | — | — | — | — | — | — | — | — |
| 23:16 | U-0 | U-0 | U-0 | U-0 | U-0 | U-0 | U-0 | U-0 |
| | — | — | — | — | — | — | — | — |
| 15:8 | R/W-0 | R/W-0 | R/W-0 | R/W-0 | R/W-0 | R/W-0 | R/W-0 | R/W-0 |
| | CHCSIZ<15:8> | | | | | | | |
| 7:0 | R/W-0 | R/W-0 | R/W-0 | R/W-0 | R/W-0 | R/W-0 | R/W-0 | R/W-0 |
| | CHCSIZ<7:0> | | | | | | | |

Legend:

R = Readable bit W = Writable bit U = Unimplemented bit, read as '0'
-n = Value at POR '1' = Bit is set '0' = Bit is cleared x = Bit is unknown

bit 31-16 **Unimplemented:** Read as '0'

bit 15-0 **CHCSIZ<15:0>:** Channel Cell-Size bits

1111111111111111 = 65,535 bytes transferred on an event

•
•
•

0000000000000010 = 2 bytes transferred on an event

0000000000000001 = 1 byte transferred on an event

0000000000000000 = 65,536 bytes transferred on an event

REGISTER 10-17: DCHxCPTR: DMA CHANNEL x CELL POINTER REGISTER

| Bit Range | Bit 31/23/15/7 | Bit 30/22/14/6 | Bit 29/21/13/5 | Bit 28/20/12/4 | Bit 27/19/11/3 | Bit 26/18/10/2 | Bit 25/17/9/1 | Bit 24/16/8/0 |
|-----------|----------------|----------------|----------------|----------------|----------------|----------------|---------------|---------------|
| 31:24 | U-0 | U-0 | U-0 | U-0 | U-0 | U-0 | U-0 | U-0 |
| | — | — | — | — | — | — | — | — |
| 23:16 | U-0 | U-0 | U-0 | U-0 | U-0 | U-0 | U-0 | U-0 |
| | — | — | — | — | — | — | — | — |
| 15:8 | R-0 | R-0 | R-0 | R-0 | R-0 | R-0 | R-0 | R-0 |
| | CHCPTR<15:8> | | | | | | | |
| 7:0 | R-0 | R-0 | R-0 | R-0 | R-0 | R-0 | R-0 | R-0 |
| | CHCPTR<7:0> | | | | | | | |

Legend:

R = Readable bit W = Writable bit U = Unimplemented bit, read as '0'
-n = Value at POR '1' = Bit is set '0' = Bit is cleared x = Bit is unknown

bit 31-16 **Unimplemented:** Read as '0'

bit 15-0 **CHCPTR<15:0>:** Channel Cell Progress Pointer bits

1111111111111111 = 65,535 bytes have been transferred since the last event

•
•
•

0000000000000001 = 1 byte has been transferred since the last event

0000000000000000 = 0 bytes have been transferred since the last event

Note: When in Pattern Detect mode, this register is reset on a pattern detect.

PIC32MZ Embedded Connectivity with Floating Point Unit (EF) Family

REGISTER 10-18: DCHxDAT: DMA CHANNEL x PATTERN DATA REGISTER

| Bit Range | Bit 31/23/15/7 | Bit 30/22/14/6 | Bit 29/21/13/5 | Bit 28/20/12/4 | Bit 27/19/11/3 | Bit 26/18/10/2 | Bit 25/17/9/1 | Bit 24/16/8/0 |
|-----------|----------------|----------------|----------------|----------------|----------------|----------------|---------------|---------------|
| 31:24 | U-0 | U-0 | U-0 | U-0 | U-0 | U-0 | U-0 | U-0 |
| | — | — | — | — | — | — | — | — |
| 23:16 | U-0 | U-0 | U-0 | U-0 | U-0 | U-0 | U-0 | U-0 |
| | — | — | — | — | — | — | — | — |
| 15:8 | R/W-0 | R/W-0 | R/W-0 | R/W-0 | R/W-0 | R/W-0 | R/W-0 | R/W-0 |
| | CHPDAT<15:8> | | | | | | | |
| 7:0 | R/W-0 | R/W-0 | R/W-0 | R/W-0 | R/W-0 | R/W-0 | R/W-0 | R/W-0 |
| | CHPDAT<7:0> | | | | | | | |

Legend:

R = Readable bit

W = Writable bit

U = Unimplemented bit, read as '0'

-n = Value at POR

'1' = Bit is set

'0' = Bit is cleared

x = Bit is unknown

bit 31-16 **Unimplemented:** Read as '0'

bit 15-0 **CHPDAT<15:0>:** Channel Data Register bits

Pattern Terminate mode:

Data to be matched must be stored in this register to allow terminate on match.

All other modes:

Unused.

PIC32MZ Embedded Connectivity with Floating Point Unit (EF) Family

NOTES:

11.0 HI-SPEED USB WITH ON-THE-GO (OTG)

Note: This data sheet summarizes the features of the PIC32MZ EF family of devices. It is not intended to be a comprehensive reference source. To complement the information in this data sheet, refer to **Section 51. “Hi-Speed USB with On-The-Go (OTG)”** (DS60001326) in the *“PIC32 Family Reference Manual”*, which is available from the Microchip web site (www.microchip.com/PIC32).

The Universal Serial Bus (USB) module contains analog and digital components to provide a USB 2.0 embedded host, device, or OTG implementation with a minimum of external components.

The module supports Hi-Speed, Full-Speed, or Low-Speed in any of the operating modes. This module in Host mode is intended for use as an embedded host and therefore does not implement a UHCI or OHCI controller.

The USB module consists of the RAM controller, packet encode/decode, UTM synchronization, endpoint control, a dedicated USB DMA controller, pull-up and pull-down resistors, and the register interface. A block diagram of the PIC32 USB OTG module is presented in [Figure 11-1](#).

The USB module includes the following features:

- USB Hi-Speed, Full-Speed, and Low-Speed support for host and device
- USB OTG support with one or more Hi-Speed, Full-Speed, or Low-Speed device
- Integrated signaling resistors
- Integrated analog comparators for VBUS monitoring
- Integrated USB transceiver
- Transaction handshaking performed by hardware
- Integrated 8-channel DMA to access system RAM and Flash
- Seven transmit endpoints and seven receive endpoints, in addition to Endpoint 0
- Session Request Protocol (SRP) and Host Negotiation Protocol (HNP) support
- Suspend and resume signaling support
- Dynamic FIFO sizing
- Integrated RAM for the FIFOs, eliminating the need for system RAM for the FIFOs
- Link power management support

Note 1: The implementation and use of the USB specifications, as well as other third party specifications or technologies, may require licensing; including, but not limited to, USB Implementers Forum, Inc. (also referred to as USB-IF). The user is fully responsible for investigating and satisfying any applicable licensing obligations.

2: If the USB module is used, the Primary Oscillator (POSC) is limited to either 12 MHz or 24 MHz.

FIGURE 11-1: PIC32MZ EF FAMILY USB INTERFACE DIAGRAM

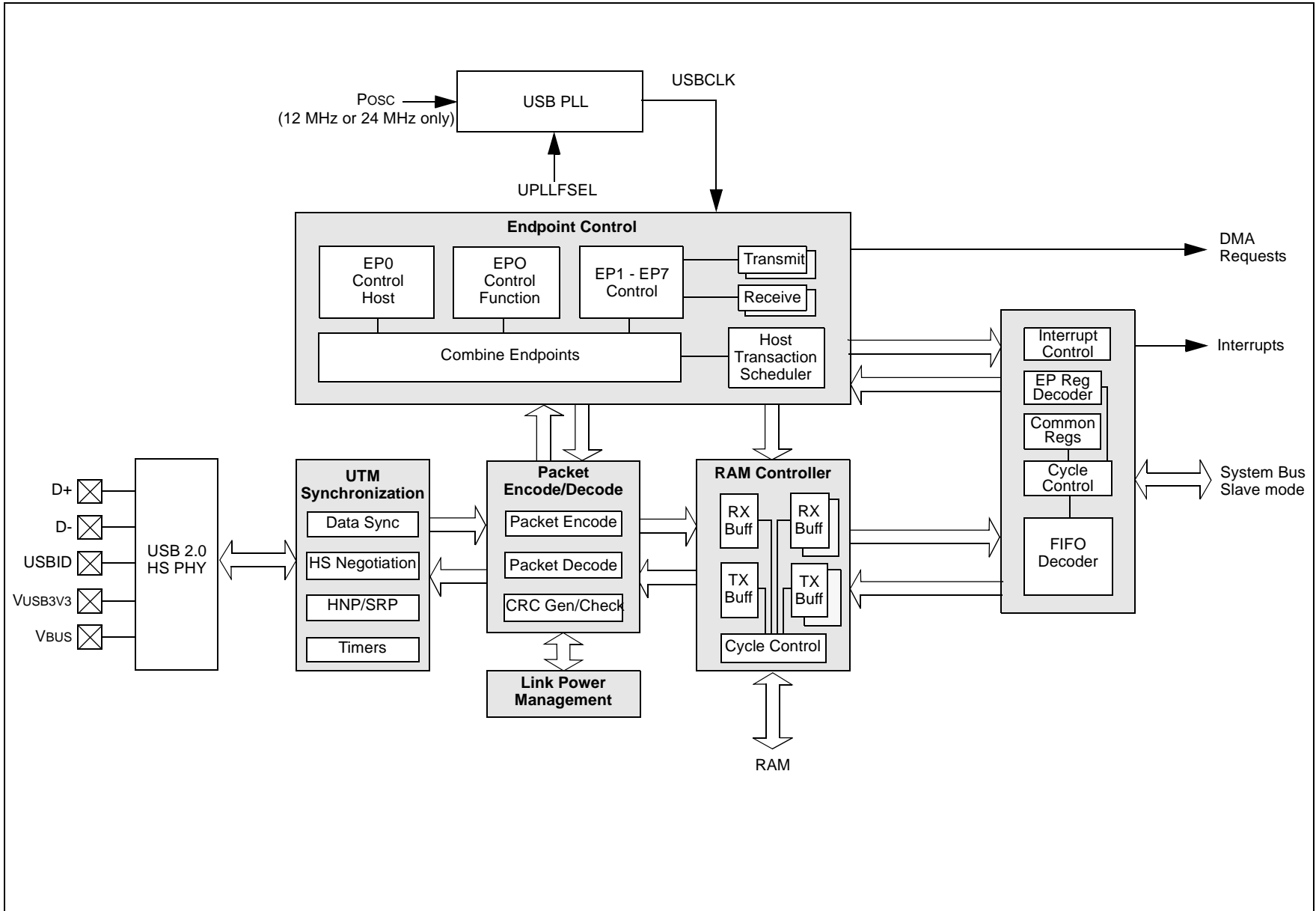

11.1 USB OTG Control Registers

TABLE 11-1: USB REGISTER MAP 1

| Virtual Address (BF8E #) | Register Name | Bit Range | Bits | | | | | | | | | | | | | | | All Resets | | | | |
|--------------------------|---------------------------------|-----------|---|---|--------------|---|---------------------------|-----------------------|-----------------------------|------------------|------------------------------|-----------------------------|------------------------------|------------------------------|-----------------------------|------------------------------|----------------------|--------------|-------|--|------|------|
| | | | 31/15 | 30/14 | 29/13 | 28/12 | 27/11 | 26/10 | 25/9 | 24/8 | 23/7 | 22/6 | 21/5 | 20/4 | 19/3 | 18/2 | 17/1 | | 16/0 | | | |
| 3000 | USBCSR0 | 31:16 | — | — | — | — | — | — | — | — | — | — | — | — | — | — | — | — | — | — | 0000 | |
| | | 15:0 | ISOUPD ⁽¹⁾ — ⁽²⁾ | SOFT CONN ⁽¹⁾ — ⁽²⁾ | HSEN | HSMODE | RESET | RESUME | SUSP MODE | SUSPEN | — | EP7TXIF | EP6TXIF | EP5TXIF | EP4TXIF | EP3TXIF | EP2TXIF | EP1TXIF | EP0IF | FUNC<6:0> ⁽¹⁾ — ⁽²⁾ — ⁽²⁾ — ⁽²⁾ — ⁽²⁾ — ⁽²⁾ — ⁽²⁾ — ⁽²⁾ | | 2000 |
| 3004 | USBCSR1 | 31:16 | — | — | — | — | — | — | — | — | — | — | — | — | — | — | — | — | — | — | 00FF | |
| | | 15:0 | — | — | — | — | — | — | — | — | — | — | — | — | — | — | — | — | — | — | 0000 | |
| 3008 | USBCSR2 | 31:16 | VBUSERRIE | SESSRQIE | DISCONIE | CONNIE | SOFIE | RESETEIE | RESUMEIE | SUSPIE | VBUSERRIF | SESSREQIF | DISCONIF | CONNIF | SOFIF | RESETEIF | RESUMEIF | SUSPIF | — | — | — | 0600 |
| | | 15:0 | — | — | — | — | — | — | — | — | — | — | — | — | — | — | — | — | — | — | — | 00FE |
| 300C | USBCSR3 | 31:16 | FORCEHST | FIFOACC | FORCEFS | FORCEHS | PACKET | TESTK | TESTJ | NAK | — | — | — | — | — | — | — | — | — | — | 0000 | |
| | | 15:0 | — | — | — | — | — | — | — | — | — | — | — | — | — | — | — | — | — | — | — | 0000 |
| 3010 | USB IE0CSR0 ⁽³⁾ | 31:16 | — | — | — | — | — ⁽¹⁾ | — ⁽¹⁾ | — ⁽¹⁾ | FLSHFIFO | SVC SETEND ⁽¹⁾ | SVCPRP ⁽¹⁾ | SEND STALL ⁽¹⁾ | SETUP END ⁽¹⁾ | DATAEND ⁽¹⁾ | SENT STALL ⁽¹⁾ | TXPKT RDY | RXPKT RDY | — | — | — | 0000 |
| | | 15:0 | — | — | — | — | DISPING ⁽²⁾ | DTWREN ⁽²⁾ | DATA TGGL ⁽²⁾ | — | NAK TMOUT ⁽²⁾ | STATPKT ⁽²⁾ | REQPKT ⁽²⁾ | ERROR ⁽²⁾ | SETUP PKT ⁽²⁾ | RXSTALL ⁽²⁾ | — | — | — | — | — | 0000 |
| 3018 | USB IE0CSR2 ⁽³⁾ | 31:16 | — | — | — | — | — | — | — | — | — | — | — | — | — | — | — | — | — | — | — | 0000 |
| | | 15:0 | — | — | — | — | — | — | — | — | — | — | — | — | — | — | — | — | — | — | — | 0000 |
| 301C | USB IE0CSR3 ⁽³⁾ | 31:16 | MPRXEN | MPTXEN | BIGEND | HBRXEN | HBTXEN | DYNFIFOS | SOFTCONE | UTMIDWID | — | — | — | — | — | — | — | — | — | — | — | xx00 |
| | | 15:0 | — | — | — | — | — | — | — | — | — | — | — | — | — | — | — | — | — | — | — | 0000 |
| 3010 | USB IENCSR0 ⁽⁴⁾ | 31:16 | AUTOSET | ISO ⁽¹⁾ — | MODE | DMA REQEN | FRC DATG | DMA REQMD | — ⁽¹⁾ | — ⁽¹⁾ | INCOMP TX ⁽¹⁾ | CLRDT | SENT STALL ⁽¹⁾ | SEND STALL ⁽¹⁾ | FLUSH | UNDER RUN ⁽¹⁾ | FIFONE | TXPKT RDY | — | — | — | 0000 |
| | | 15:0 | MULT<4:0> | | | | TXMAXP<10:0> | | | | DATA TGGL ⁽²⁾ | NAK TMOUT ⁽²⁾ | — | — | — | ERROR ⁽²⁾ | — | — | — | — | — | 0000 |
| 3014 | USB IENCSR1 ⁽⁴⁾ | 31:16 | AUTOCLR | ISO ⁽¹⁾ AUTORQ ⁽²⁾ | DMA REQEN | DISNYET ⁽¹⁾ PIDERR ⁽²⁾ | DMA REQMD | — ⁽¹⁾ | — ⁽¹⁾ | INCOM PRX | CLRDT | SENTSTALL ⁽¹⁾ | SENDSTALL ⁽¹⁾ | FLUSH | DATAERR ⁽¹⁾ | OVERRUN ⁽¹⁾ | FIFOFULL | RXPKT RDY | — | — | — | 0000 |
| | | 15:0 | MULT<4:0> | | | | RXMAXP<10:0> | | | | DATA TWEN ⁽²⁾ | DATA TGGL ⁽²⁾ | — | — | — | DERR- NAKT ⁽¹⁾ | ERROR ⁽²⁾ | — | — | — | — | 0000 |
| 3018 | USB IENCSR2 ⁽⁴⁾ | 31:16 | TXINTERV<7:0> ⁽²⁾ | | | | SPEED<1:0> ⁽²⁾ | | | | PROTOCOL<1:0> | | | | TEP<3:0> | | | | 0000 | | | |
| | | 15:0 | — | — | — | — | RXCNT<13:0> | | | | — | — | — | — | — | — | — | — | — | — | — | 0000 |
| 301C | USB IENCSR3 ^(1,3) | 31:16 | RXFIFOSZ<3:0> | | | | TXFIFOSZ<3:0> | | | | — | — | — | — | — | — | — | — | — | — | — | 0000 |
| | | 15:0 | RXINTERV<7:0> | | | | SPEED<1:0> | | | | PROTOCOL<1:0> | | | | TEP<3:0> | | | | 0000 | | | |
| 3020 | USB FIFO0 | 31:16 | DATA<31:16> | | | | | | | | | | | | | | | 0000 | | | | |
| | | 15:0 | DATA<15:0> | | | | | | | | | | | | | | | 0000 | | | | |
| 3024 | USB FIFO1 | 31:16 | DATA<31:16> | | | | | | | | | | | | | | | 0000 | | | | |
| | | 15:0 | DATA<15:0> | | | | | | | | | | | | | | | 0000 | | | | |

Legend: x = unknown value on Reset; — = unimplemented, read as '0'. Reset values are shown in hexadecimal.

- Note
- 1: Device mode.
 - 2: Host mode.
 - 3: Definition for Endpoint 0 (ENDPOINT<3:0> (USBCSR<19:16>) = 0).
 - 4: Definition for Endpoints 1-7 (ENDPOINT<3:0> (USBCSR<19:16>) = 1 through 7).

TABLE 11-1: USB REGISTER MAP 1 (CONTINUED)

| Virtual Address (BFSE #) | Register Name | Bit Range | Bits | | | | | | | | | | | | | | All Resets | |
|-----------------------------|------------------|-----------|---------------|---------------|-------|----------------|---------------|------------|---------------|------------|---------------|-------|-----------|---------------|---------------|---------|------------|------|
| | | | 31/15 | 30/14 | 29/13 | 28/12 | 27/11 | 26/10 | 25/9 | 24/8 | 23/7 | 22/6 | 21/5 | 20/4 | 19/3 | 18/2 | | 17/1 |
| 3028 | USB FIFO2 | 31:16 | DATA<31:16> | | | | | | | | | | | | | | 0000 | |
| | | 15:0 | DATA<15:0> | | | | | | | | | | | | | | 0000 | |
| 302C | USB FIFO3 | 31:16 | DATA<31:16> | | | | | | | | | | | | | | 0000 | |
| | | 15:0 | DATA<15:0> | | | | | | | | | | | | | | 0000 | |
| 3030 | USB FIFO4 | 31:16 | DATA<31:16> | | | | | | | | | | | | | | 0000 | |
| | | 15:0 | DATA<15:0> | | | | | | | | | | | | | | 0000 | |
| 3034 | USB FIFO5 | 31:16 | DATA<31:16> | | | | | | | | | | | | | | 0000 | |
| | | 15:0 | DATA<15:0> | | | | | | | | | | | | | | 0000 | |
| 3038 | USB FIFO6 | 31:16 | DATA<31:16> | | | | | | | | | | | | | | 0000 | |
| | | 15:0 | DATA<15:0> | | | | | | | | | | | | | | 0000 | |
| 303C | USB FIFO7 | 31:16 | DATA<31:16> | | | | | | | | | | | | | | 0000 | |
| | | 15:0 | DATA<15:0> | | | | | | | | | | | | | | 0000 | |
| 3060 | USBOTG | 31:16 | — | — | — | RXDPB | RXFIFOSZ<3:0> | | | — | — | — | TXDPB | TXFIFOSZ<3:0> | | | 0000 | |
| | | 15:0 | — | — | — | — | — | — | TXEDMA | RXEDMA | BDEV | FSDEV | LSDEV | VBUS<1:0> | HOSTMODE | HOSTREQ | SESSION | 0080 |
| 3064 | USB FIFOA | 31:16 | — | — | — | RXFIFOAD<12:0> | | | | | | | | | | | 0000 | |
| | | 15:0 | — | — | — | TXFIFOAD<12:0> | | | | | | | | | | | 0000 | |
| 306C | USB HWVER | 31:16 | — | — | — | — | — | — | — | — | — | — | — | — | — | — | — | 0000 |
| | | 15:0 | RC | VERMAJOR<4:0> | | | | | VERMINOR<9:0> | | | | | | | | | 0800 |
| 3078 | USB INFO | 31:16 | VPLEN<7:0> | | | | | WTCON<3:0> | | | | | WTID<3:0> | | | | | 3C5C |
| | | 15:0 | DMACHANS<3:0> | | | | RAMBITS<3:0> | | | | RXENDPTS<3:0> | | | | TXENDPTS<3:0> | | | |
| 307C | USB EOFRST | 31:16 | — | — | — | — | — | — | NRSTX | NRST | LSEOF<7:0> | | | | | | | 0072 |
| | | 15:0 | FSEOF<7:0> | | | | | | | HSEOF<7:0> | | | | | | | 7780 | |
| 3080 | USB E0TXA | 31:16 | — | TXHUBPRT<6:0> | | | | | | MULTTRAN | TXHUBADD<6:0> | | | | | | 0000 | |
| | | 15:0 | — | — | — | — | — | — | — | — | TXFADDR<6:0> | | | | | | 0000 | |
| 3084 | USB E0RXA | 31:16 | — | RXHUBPRT<6:0> | | | | | | MULTTRAN | RXHUBADD<6:0> | | | | | | 0000 | |
| | | 15:0 | — | — | — | — | — | — | — | — | — | — | — | — | — | — | — | 0000 |
| 3088 | USB E1TXA | 31:16 | — | TXHUBPRT<6:0> | | | | | | MULTTRAN | TXHUBADD<6:0> | | | | | | 0000 | |
| | | 15:0 | — | — | — | — | — | — | — | — | TXFADDR<6:0> | | | | | | 0000 | |
| 308C | USB E1RXA | 31:16 | — | RXHUBPRT<6:0> | | | | | | MULTTRAN | RXHUBADD<6:0> | | | | | | 0000 | |
| | | 15:0 | — | — | — | — | — | — | — | — | RXFADDR<6:0> | | | | | | 0000 | |
| 3090 | USB E2TXA | 31:16 | — | TXHUBPRT<6:0> | | | | | | MULTTRAN | TXHUBADD<6:0> | | | | | | 0000 | |
| | | 15:0 | — | — | — | — | — | — | — | — | TXFADDR<6:0> | | | | | | 0000 | |
| 3094 | USB E2RXA | 31:16 | — | RXHUBPRT<6:0> | | | | | | MULTTRAN | RXHUBADD<6:0> | | | | | | 0000 | |
| | | 15:0 | — | — | — | — | — | — | — | — | RXFADDR<6:0> | | | | | | 0000 | |
| 3098 | USB E3TXA | 31:16 | — | TXHUBPRT<6:0> | | | | | | MULTTRAN | TXHUBADD<6:0> | | | | | | 0000 | |
| | | 15:0 | — | — | — | — | — | — | — | — | TXFADDR<6:0> | | | | | | 0000 | |

Legend: x = unknown value on Reset; — = unimplemented, read as '0'. Reset values are shown in hexadecimal.

- Note**
- 1: Device mode.
 - 2: Host mode.
 - 3: Definition for Endpoint 0 (ENDPOINT<3:0> (USBCSR<19:16>) = 0).
 - 4: Definition for Endpoints 1-7 (ENDPOINT<3:0> (USBCSR<19:16>) = 1 through 7).

TABLE 11-1: USB REGISTER MAP 1 (CONTINUED)

| Virtual Address (BFSE_#) | Register Name | Bit Range | Bits | | | | | | | | | | | | | | | All Resets | |
|-----------------------------|------------------|-----------|--|---------------|-------|-------|-------|-------|------|------|----------|---------------|------|------|------|------|------|------------|------|
| | | | 31/15 | 30/14 | 29/13 | 28/12 | 27/11 | 26/10 | 25/9 | 24/8 | 23/7 | 22/6 | 21/5 | 20/4 | 19/3 | 18/2 | 17/1 | | 16/0 |
| 309C | USB E3RXA | 31:16 | — | RXHUBPRT<6:0> | | | | | | | MULTTRAN | RXHUBADD<6:0> | | | | | | | 0000 |
| | | 15:0 | — | — | — | — | — | — | — | — | — | RXFADDR<6:0> | | | | | | | 0000 |
| 30A0 | US BE4TXA | 31:16 | — | TXHUBPRT<6:0> | | | | | | | MULTTRAN | TXHUBADD<6:0> | | | | | | | 0000 |
| | | 15:0 | — | — | — | — | — | — | — | — | — | TXFADDR<6:0> | | | | | | | 0000 |
| 30A4 | USB E4RXA | 31:16 | — | RXHUBPRT<6:0> | | | | | | | MULTTRAN | RXHUBADD<6:0> | | | | | | | 0000 |
| | | 15:0 | — | — | — | — | — | — | — | — | — | RXFADDR<6:0> | | | | | | | 0000 |
| 30A8 | USB E5TXA | 31:16 | — | TXHUBPRT<6:0> | | | | | | | MULTTRAN | TXHUBADD<6:0> | | | | | | | 0000 |
| | | 15:0 | — | — | — | — | — | — | — | — | — | TXFADDR<6:0> | | | | | | | 0000 |
| 30AC | USB E5RXA | 31:16 | — | RXHUBPRT<6:0> | | | | | | | MULTTRAN | RXHUBADD<6:0> | | | | | | | 0000 |
| | | 15:0 | — | — | — | — | — | — | — | — | — | RXFADDR<6:0> | | | | | | | 0000 |
| 30B0 | USB E6TXA | 31:16 | — | TXHUBPRT<6:0> | | | | | | | MULTTRAN | TXHUBADD<6:0> | | | | | | | 0000 |
| | | 15:0 | — | — | — | — | — | — | — | — | — | TXFADDR<6:0> | | | | | | | 0000 |
| 30B4 | USB E6RXA | 31:16 | — | RXHUBPRT<6:0> | | | | | | | MULTTRAN | RXHUBADD<6:0> | | | | | | | 0000 |
| | | 15:0 | — | — | — | — | — | — | — | — | — | RXFADDR<6:0> | | | | | | | 0000 |
| 30B8 | USB E7TXA | 31:16 | — | TXHUBPRT<6:0> | | | | | | | MULTTRAN | TXHUBADD<6:0> | | | | | | | 0000 |
| | | 15:0 | — | — | — | — | — | — | — | — | — | TXFADDR<6:0> | | | | | | | 0000 |
| 30BC | USB E7RXA | 31:16 | — | RXHUBPRT<6:0> | | | | | | | MULTTRAN | RXHUBADD<6:0> | | | | | | | 0000 |
| | | 15:0 | — | — | — | — | — | — | — | — | — | RXFADDR<6:0> | | | | | | | 0000 |
| 3100 | USB E0CSR0 | 31:16 | Indexed by the same bits in USBIE0CSR0 | | | | | | | | | | | | | | | 0000 | |
| | | 15:0 | Indexed by the same bits in USBIE0CSR0 | | | | | | | | | | | | | | | 0000 | |
| 3108 | USB E0CSR2 | 31:16 | Indexed by the same bits in USBIE0CSR2 | | | | | | | | | | | | | | | 0000 | |
| | | 15:0 | Indexed by the same bits in USBIE0CSR2 | | | | | | | | | | | | | | | 0000 | |
| 310C | USB E0CSR3 | 31:16 | Indexed by the same bits in USBIE0CSR3 | | | | | | | | | | | | | | | 0000 | |
| | | 15:0 | Indexed by the same bits in USBIE0CSR3 | | | | | | | | | | | | | | | 0000 | |
| 3110 | USB E1CSR0 | 31:16 | Indexed by the same bits in USBIE1CSR0 | | | | | | | | | | | | | | | 0000 | |
| | | 15:0 | Indexed by the same bits in USBIE1CSR0 | | | | | | | | | | | | | | | 0000 | |
| 3114 | USB E1CSR1 | 31:16 | Indexed by the same bits in USBIE1CSR1 | | | | | | | | | | | | | | | 0000 | |
| | | 15:0 | Indexed by the same bits in USBIE1CSR1 | | | | | | | | | | | | | | | 0000 | |
| 3118 | USB E1CSR2 | 31:16 | Indexed by the same bits in USBIE1CSR2 | | | | | | | | | | | | | | | 0000 | |
| | | 15:0 | Indexed by the same bits in USBIE1CSR2 | | | | | | | | | | | | | | | 0000 | |
| 311C | USB E1CSR3 | 31:16 | Indexed by the same bits in USBIE1CSR3 | | | | | | | | | | | | | | | 0000 | |
| | | 15:0 | Indexed by the same bits in USBIE1CSR3 | | | | | | | | | | | | | | | 0000 | |
| 3120 | USB E2CSR0 | 31:16 | Indexed by the same bits in USBIE2CSR0 | | | | | | | | | | | | | | | 0000 | |
| | | 15:0 | Indexed by the same bits in USBIE2CSR0 | | | | | | | | | | | | | | | 0000 | |
| 3124 | USB E2CSR1 | 31:16 | Indexed by the same bits in USBIE2CSR1 | | | | | | | | | | | | | | | 0000 | |
| | | 15:0 | Indexed by the same bits in USBIE2CSR1 | | | | | | | | | | | | | | | 0000 | |

Legend: x = unknown value on Reset; — = unimplemented, read as '0'. Reset values are shown in hexadecimal.

- Note**
- 1: Device mode.
 - 2: Host mode.
 - 3: Definition for Endpoint 0 (ENDPOINT<3:0> (USBCSR<19:16>) = 0).
 - 4: Definition for Endpoints 1-7 (ENDPOINT<3:0> (USBCSR<19:16>) = 1 through 7).

TABLE 11-1: USB REGISTER MAP 1 (CONTINUED)

| Virtual Address (BF8E-#) | Register Name | Bit Range | Bits | | | | | | | | | | | | | | All Resets |
|-----------------------------|------------------|-----------|--|-------|-------|-------|-------|-------|------|------|------|------|------|------|------|------|------------|
| | | | 31/15 | 30/14 | 29/13 | 28/12 | 27/11 | 26/10 | 25/9 | 24/8 | 23/7 | 22/6 | 21/5 | 20/4 | 19/3 | 18/2 | |
| 3128 | USB E2CSR2 | 31:16 | Indexed by the same bits in USBIE2CSR2 | | | | | | | | | | | | | | 0000 |
| | | 15:0 | | | | | | | | | | | | | | | 0000 |
| 312C | USB E2CSR3 | 31:16 | Indexed by the same bits in USBIE2CSR3 | | | | | | | | | | | | | | 0000 |
| | | 15:0 | | | | | | | | | | | | | | | 0000 |
| 3130 | USB E3CSR0 | 31:16 | Indexed by the same bits in USBIE3CSR0 | | | | | | | | | | | | | | 0000 |
| | | 15:0 | | | | | | | | | | | | | | | 0000 |
| 3134 | USB E3CSR1 | 31:16 | Indexed by the same bits in USBIE3CSR1 | | | | | | | | | | | | | | 0000 |
| | | 15:0 | | | | | | | | | | | | | | | 0000 |
| 3138 | USB E3CSR2 | 31:16 | Indexed by the same bits in USBIE3CSR2 | | | | | | | | | | | | | | 0000 |
| | | 15:0 | | | | | | | | | | | | | | | 0000 |
| 313C | USB E3CSR3 | 31:16 | Indexed by the same bits in USBIE3CSR3 | | | | | | | | | | | | | | 0000 |
| | | 15:0 | | | | | | | | | | | | | | | 0000 |
| 3140 | USB E4CSR0 | 31:16 | Indexed by the same bits in USBIE4CSR0 | | | | | | | | | | | | | | 0000 |
| | | 15:0 | | | | | | | | | | | | | | | 0000 |
| 3144 | USB E4CSR1 | 31:16 | Indexed by the same bits in USBIE4CSR1 | | | | | | | | | | | | | | 0000 |
| | | 15:0 | | | | | | | | | | | | | | | 0000 |
| 3148 | USB E4CSR2 | 31:16 | Indexed by the same bits in USBIE4CSR2 | | | | | | | | | | | | | | 0000 |
| | | 15:0 | | | | | | | | | | | | | | | 0000 |
| 314C | USB E4CSR3 | 31:16 | Indexed by the same bits in USBIE4CSR3 | | | | | | | | | | | | | | 0000 |
| | | 15:0 | | | | | | | | | | | | | | | 0000 |
| 3150 | USB E5CSR0 | 31:16 | Indexed by the same bits in USBIE5CSR0 | | | | | | | | | | | | | | 0000 |
| | | 15:0 | | | | | | | | | | | | | | | 0000 |
| 3154 | USB E5CSR1 | 31:16 | Indexed by the same bits in USBIE5CSR1 | | | | | | | | | | | | | | 0000 |
| | | 15:0 | | | | | | | | | | | | | | | 0000 |
| 3158 | USB E5CSR2 | 31:16 | Indexed by the same bits in USBIE5CSR2 | | | | | | | | | | | | | | 0000 |
| | | 15:0 | | | | | | | | | | | | | | | 0000 |
| 315C | USB E5CSR3 | 31:16 | Indexed by the same bits in USBIE5CSR3 | | | | | | | | | | | | | | 0000 |
| | | 15:0 | | | | | | | | | | | | | | | 0000 |
| 3160 | USB E6CSR0 | 31:16 | Indexed by the same bits in USBIE6CSR0 | | | | | | | | | | | | | | 0000 |
| | | 15:0 | | | | | | | | | | | | | | | 0000 |
| 3164 | USB E6CSR1 | 31:16 | Indexed by the same bits in USBIE6CSR1 | | | | | | | | | | | | | | 0000 |
| | | 15:0 | | | | | | | | | | | | | | | 0000 |
| 3168 | USB E6CSR2 | 31:16 | Indexed by the same bits in USBIE6CSR2 | | | | | | | | | | | | | | 0000 |
| | | 15:0 | | | | | | | | | | | | | | | 0000 |
| 316C | USB E6CSR3 | 31:16 | Indexed by the same bits in USBIE6CSR3 | | | | | | | | | | | | | | 0000 |
| | | 15:0 | | | | | | | | | | | | | | | 0000 |

Legend: x = unknown value on Reset; — = unimplemented, read as '0'. Reset values are shown in hexadecimal.

- Note**
- 1: Device mode.
 - 2: Host mode.
 - 3: Definition for Endpoint 0 (ENDPOINT<3:0> (USBCSR<19:16>) = 0).
 - 4: Definition for Endpoints 1-7 (ENDPOINT<3:0> (USBCSR<19:16>) = 1 through 7).

TABLE 11-1: USB REGISTER MAP 1 (CONTINUED)

| Virtual Address (BF8E_#) | Register Name | Bit Range | Bits | | | | | | | | | | | | | | All Resets | | |
|-----------------------------|------------------|-----------|--|-------|-------|-------|-------|-------|---------------|--------|------------|--------|--------|--------|---------|--------|------------|--------|------|
| | | | 31/15 | 30/14 | 29/13 | 28/12 | 27/11 | 26/10 | 25/9 | 24/8 | 23/7 | 22/6 | 21/5 | 20/4 | 19/3 | 18/2 | | 17/1 | 16/0 |
| 3170 | USB E7CSR0 | 31:16 | Indexed by the same bits in USBIE7CSR0 | | | | | | | | | | | | | | 0000 | | |
| | | 15:0 | | | | | | | | | | | | | | | 0000 | | |
| 3174 | USB E7CSR1 | 31:16 | Indexed by the same bits in USBIE7CSR1 | | | | | | | | | | | | | | 0000 | | |
| | | 15:0 | | | | | | | | | | | | | | | 0000 | | |
| 3178 | USB E7CSR2 | 31:16 | Indexed by the same bits in USBIE7CSR2 | | | | | | | | | | | | | | 0000 | | |
| | | 15:0 | | | | | | | | | | | | | | | 0000 | | |
| 317C | USB E7CSR3 | 31:16 | Indexed by the same bits in USBIE7CSR3 | | | | | | | | | | | | | | 0000 | | |
| | | 15:0 | | | | | | | | | | | | | | | 0000 | | |
| 3200 | USB DMAINT | 31:16 | — | — | — | — | — | — | — | — | — | — | — | — | — | — | — | — | 0000 |
| | | 15:0 | — | — | — | — | — | — | — | — | DMA8IF | DMA7IF | DMA6IF | DMA5IF | DMA4IF | DMA3IF | DMA2IF | DMA1IF | 0000 |
| 3204 | USB DMA1C | 31:16 | — | — | — | — | — | — | — | — | — | — | — | — | — | — | — | — | 0000 |
| | | 15:0 | — | — | — | — | — | — | DMABRSTM<1:0> | DMAERR | DMAEP<3:0> | | | DMAIE | DMAMODE | DMADIR | DMAEN | 0000 | |
| 3208 | USB DMA1A | 31:16 | DMAADDR<31:16> | | | | | | | | | | | | | | 0000 | | |
| | | 15:0 | DMAADDR<15:0> | | | | | | | | | | | | | | 0000 | | |
| 320C | USB DMA1N | 31:16 | DMACOUNT<31:16> | | | | | | | | | | | | | | 0000 | | |
| | | 15:0 | DMACOUNT<15:0> | | | | | | | | | | | | | | 0000 | | |
| 3214 | USB DMA2C | 31:16 | — | — | — | — | — | — | — | — | — | — | — | — | — | — | — | — | 0000 |
| | | 15:0 | — | — | — | — | — | — | DMABRSTM<1:0> | DMAERR | DMAEP<3:0> | | | DMAIE | DMAMODE | DMADIR | DMAEN | 0000 | |
| 3218 | USB DMA2A | 31:16 | DMAADDR<31:16> | | | | | | | | | | | | | | 0000 | | |
| | | 15:0 | DMAADDR<15:0> | | | | | | | | | | | | | | 0000 | | |
| 321C | USB DMA2N | 31:16 | DMACOUNT<31:16> | | | | | | | | | | | | | | 0000 | | |
| | | 15:0 | DMACOUNT<15:0> | | | | | | | | | | | | | | 0000 | | |
| 3224 | USB DMA3C | 31:16 | — | — | — | — | — | — | — | — | — | — | — | — | — | — | — | — | 0000 |
| | | 15:0 | — | — | — | — | — | — | DMABRSTM<1:0> | DMAERR | DMAEP<3:0> | | | DMAIE | DMAMODE | DMADIR | DMAEN | 0000 | |
| 3228 | USB DMA3A | 31:16 | DMAADDR<31:16> | | | | | | | | | | | | | | 0000 | | |
| | | 15:0 | DMAADDR<15:0> | | | | | | | | | | | | | | 0000 | | |
| 322C | USB DMA3N | 31:16 | DMACOUNT<31:16> | | | | | | | | | | | | | | 0000 | | |
| | | 15:0 | DMACOUNT<15:0> | | | | | | | | | | | | | | 0000 | | |
| 3234 | USB DMA4C | 31:16 | — | — | — | — | — | — | — | — | — | — | — | — | — | — | — | — | 0000 |
| | | 15:0 | — | — | — | — | — | — | DMABRSTM<1:0> | DMAERR | DMAEP<3:0> | | | DMAIE | DMAMODE | DMADIR | DMAEN | 0000 | |
| 3238 | USB DMA4A | 31:16 | DMAADDR<31:16> | | | | | | | | | | | | | | 0000 | | |
| | | 15:0 | DMAADDR<15:0> | | | | | | | | | | | | | | 0000 | | |
| 323C | USB DMA4N | 31:16 | DMACOUNT<31:16> | | | | | | | | | | | | | | 0000 | | |
| | | 15:0 | DMACOUNT<15:0> | | | | | | | | | | | | | | 0000 | | |
| 3244 | USB DMA5C | 31:16 | — | — | — | — | — | — | — | — | — | — | — | — | — | — | — | — | 0000 |
| | | 15:0 | — | — | — | — | — | — | DMABRSTM<1:0> | DMAERR | DMAEP<3:0> | | | DMAIE | DMAMODE | DMADIR | DMAEN | 0000 | |

Legend: x = unknown value on Reset; — = unimplemented, read as '0'. Reset values are shown in hexadecimal.

- Note
- 1: Device mode.
 - 2: Host mode.
 - 3: Definition for Endpoint 0 (ENDPOINT<3:0> (USBCSR<19:16>) = 0).
 - 4: Definition for Endpoints 1-7 (ENDPOINT<3:0> (USBCSR<19:16>) = 1 through 7).

TABLE 11-1: USB REGISTER MAP 1 (CONTINUED)

| Virtual Address (BF9E_#) | Register Name | Bit Range | Bits | | | | | | | | | | | | | | All Resets | |
|-----------------------------|------------------|-----------|-----------------|-------|-------|-------|-------|---------------|--------|------------|------|------|-------|---------|--------|-------|------------|------|
| | | | 31/15 | 30/14 | 29/13 | 28/12 | 27/11 | 26/10 | 25/9 | 24/8 | 23/7 | 22/6 | 21/5 | 20/4 | 19/3 | 18/2 | | 17/1 |
| 3248 | USB DMA5A | 31:16 | DMAADDR<31:16> | | | | | | | | | | | | | | 0000 | |
| | | 15:0 | DMAADDR<15:0> | | | | | | | | | | | | | | 0000 | |
| 324C | USB DMA5N | 31:16 | DMACOUNT<31:16> | | | | | | | | | | | | | | 0000 | |
| | | 15:0 | DMACOUNT<15:0> | | | | | | | | | | | | | | 0000 | |
| 3254 | USB DMA6C | 31:16 | — | — | — | — | — | — | — | — | — | — | — | — | — | — | — | 0000 |
| | | 15:0 | — | — | — | — | — | DMABRSTM<1:0> | DMAERR | DMAEP<3:0> | | | DMAIE | DMAMODE | DMADIR | DMAEN | 0000 | |
| 3258 | USB DMA6A | 31:16 | DMAADDR<31:16> | | | | | | | | | | | | | | 0000 | |
| | | 15:0 | DMAADDR<15:0> | | | | | | | | | | | | | | 0000 | |
| 325C | USB DMA6N | 31:16 | DMACOUNT<31:16> | | | | | | | | | | | | | | 0000 | |
| | | 15:0 | DMACOUNT<15:0> | | | | | | | | | | | | | | 0000 | |
| 3264 | USB DMA7C | 31:16 | — | — | — | — | — | — | — | — | — | — | — | — | — | — | — | 0000 |
| | | 15:0 | — | — | — | — | — | DMABRSTM<1:0> | DMAERR | DMAEP<3:0> | | | DMAIE | DMAMODE | DMADIR | DMAEN | 0000 | |
| 3268 | USB DMA7A | 31:16 | DMAADDR<31:16> | | | | | | | | | | | | | | 0000 | |
| | | 15:0 | DMAADDR<15:0> | | | | | | | | | | | | | | 0000 | |
| 326C | USB DMA7N | 31:16 | DMACOUNT<31:16> | | | | | | | | | | | | | | 0000 | |
| | | 15:0 | DMACOUNT<15:0> | | | | | | | | | | | | | | 0000 | |
| 3274 | USB DMA8C | 31:16 | — | — | — | — | — | — | — | — | — | — | — | — | — | — | — | 0000 |
| | | 15:0 | — | — | — | — | — | DMABRSTM<1:0> | DMAERR | DMAEP<3:0> | | | DMAIE | DMAMODE | DMADIR | DMAEN | 0000 | |
| 3278 | USB DMA8A | 31:16 | DMAADDR<31:16> | | | | | | | | | | | | | | 0000 | |
| | | 15:0 | DMAADDR<15:0> | | | | | | | | | | | | | | 0000 | |
| 327C | USB DMA8N | 31:16 | DMACOUNT<31:16> | | | | | | | | | | | | | | 0000 | |
| | | 15:0 | DMACOUNT<15:0> | | | | | | | | | | | | | | 0000 | |
| 3304 | USB E1RPC | 31:16 | — | — | — | — | — | — | — | — | — | — | — | — | — | — | — | 0000 |
| | | 15:0 | RQPKCNT<15:0> | | | | | | | | | | | | | | 0000 | |
| 3308 | USB E2RPC | 31:16 | — | — | — | — | — | — | — | — | — | — | — | — | — | — | — | 0000 |
| | | 15:0 | RQPKCNT<15:0> | | | | | | | | | | | | | | 0000 | |
| 330C | USB E3RPC | 31:16 | — | — | — | — | — | — | — | — | — | — | — | — | — | — | — | 0000 |
| | | 15:0 | RQPKCNT<15:0> | | | | | | | | | | | | | | 0000 | |
| 3310 | USB E4RPC | 31:16 | — | — | — | — | — | — | — | — | — | — | — | — | — | — | — | 0000 |
| | | 15:0 | RQPKCNT<15:0> | | | | | | | | | | | | | | 0000 | |
| 3314 | USB E5RPC | 31:16 | — | — | — | — | — | — | — | — | — | — | — | — | — | — | — | 0000 |
| | | 15:0 | RQPKCNT<15:0> | | | | | | | | | | | | | | 0000 | |
| 3318 | USB E6RPC | 31:16 | — | — | — | — | — | — | — | — | — | — | — | — | — | — | — | 0000 |
| | | 15:0 | RQPKCNT<15:0> | | | | | | | | | | | | | | 0000 | |
| 331C | USB E7RPC | 31:16 | — | — | — | — | — | — | — | — | — | — | — | — | — | — | — | 0000 |
| | | 15:0 | RQPKCNT<15:0> | | | | | | | | | | | | | | 0000 | |

Legend: x = unknown value on Reset; — = unimplemented, read as '0'. Reset values are shown in hexadecimal.

- Note**
- 1: Device mode.
 - 2: Host mode.
 - 3: Definition for Endpoint 0 (ENDPOINT<3:0> (USBCSR<19:16>) = 0).
 - 4: Definition for Endpoints 1-7 (ENDPOINT<3:0> (USBCSR<19:16>) = 1 through 7).

TABLE 11-1: USB REGISTER MAP 1 (CONTINUED)

| Virtual Address (BF8E_#) | Register Name | Bit Range | Bits | | | | | | | | | | | | | | | All Resets | | | |
|-----------------------------|---------------|-----------|---------------|---------------|--------------|--------------|----------|---------|-----------------------|-----------|-------|--------|---------------|-----------------------|------------|------------|--------|------------|--------|------|------|
| | | | 31/15 | 30/14 | 29/13 | 28/12 | 27/11 | 26/10 | 25/9 | 24/8 | 23/7 | 22/6 | 21/5 | 20/4 | 19/3 | 18/2 | 17/1 | | 16/0 | | |
| 3340 | USB DPBFD | 31:16 | — | — | — | — | — | — | — | — | — | EP7TXD | EP6TXD | EP5TXD | EP4TXD | EP3TXD | EP2TXD | EP1TXD | — | 0000 | |
| | | 15:0 | — | — | — | — | — | — | — | — | — | — | EP7RXD | EP6RXD | EP5RXD | EP4RXD | EP3RXD | EP2RXD | EP1RXD | — | 0000 |
| 3344 | USB TMCON1 | 31:16 | THHSRTN<15:0> | | | | | | | | | | | | | | | 05B6 | | | |
| | | 15:0 | TUCH<15:0> | | | | | | | | | | | | | | | 4074 | | | |
| 3348 | USB TMCON2 | 31:16 | — | — | — | — | — | — | — | — | — | — | — | — | — | — | — | — | — | — | 0000 |
| | | 15:0 | — | — | — | — | — | — | — | — | — | — | — | — | — | THSBT<3:0> | | | 0000 | | |
| 3360 | USB LPMR1 | 31:16 | — | — | LPM ERRIE | LPM RESIE | LPMACKIE | LPMNYIE | LPMSTIE | LPMTOIE | — | — | — | LPMNAK ⁽¹⁾ | LPMEN<1:0> | | — | LPMRES | LPMXMT | 0000 | |
| | | 15:0 | ENDPOINT<3:0> | | | — | — | — | RMTWAK | HIRD<3:0> | | | LNKSTATE<3:0> | | | 0000 | | | | | |
| | | | — | LPMFADDR<6:0> | | | — | — | LPMERR ⁽¹⁾ | LPMRES | LPMNC | LPMACK | LPMNY | LPMST | 0000 | | | | | | |
| 3364 | USB LPMR2 | 15:0 | — | LPMFADDR<6:0> | | | — | — | — | — | — | — | — | — | — | — | — | — | — | 0000 | |
| | | | — | LPMFADDR<6:0> | | | — | — | — | — | — | — | — | — | — | — | — | — | — | — | 0000 |

Legend: x = unknown value on Reset; — = unimplemented, read as '0'. Reset values are shown in hexadecimal.

- Note**
- 1: Device mode.
 - 2: Host mode.
 - 3: Definition for Endpoint 0 (ENDPOINT<3:0> (USBCSR<19:16>) = 0).
 - 4: Definition for Endpoints 1-7 (ENDPOINT<3:0> (USBCSR<19:16>) = 1 through 7).

TABLE 11-2: USB REGISTER MAP 2

| Virtual Address (BF88_#) | Register Name | Bit Range | Bits | | | | | | | | | | | | | | | All Resets | | | |
|-----------------------------|---------------|-----------|-------|-------|-------|-------|-------|-------|---------------|--------------|---------|---------------|----------------|----------------|---------------|-------|--------|---------------|------|---|------|
| | | | 31/15 | 30/14 | 29/13 | 28/12 | 27/11 | 26/10 | 25/9 | 24/8 | 23/7 | 22/6 | 21/5 | 20/4 | 19/3 | 18/2 | 17/1 | | 16/0 | | |
| 4000 | USB CRCON | 31:16 | — | — | — | — | — | USBIF | USBRF | USBWKUP | — | — | — | — | — | — | — | — | — | — | 0100 |
| | | 15:0 | — | — | — | — | — | — | USB IDOVEN | USB IDVAL | PHYIDEN | VBUS MONEN | ASVAL MONEN | BSVAL MONEN | SEND MONEN | USBIE | USBRIE | USB WKUPEN | 8000 | | |

Legend: x = unknown value on Reset; — = unimplemented, read as '0'. Reset values are shown in hexadecimal.

PIC32MZ Embedded Connectivity with Floating Point Unit (EF) Family

REGISTER 11-1: USBCSR0: USB CONTROL STATUS REGISTER 0

| Bit Range | Bit 31/23/15/7 | Bit 30/22/14/6 | Bit 29/21/13/5 | Bit 28/20/12/4 | Bit 27/19/11/3 | Bit 26/18/10/2 | Bit 25/17/9/1 | Bit 24/16/8/0 |
|-----------|--------------------|--------------------|--------------------|--------------------|--------------------|--------------------|---------------------|------------------|
| 31:24 | U-0 — | U-0 — | U-0 — | U-0 — | U-0 — | U-0 — | U-0 — | U-0 — |
| 23:16 | R-0, HS EP7TXIF | R-0, HS EP6TXIF | R-0, HS EP5TXIF | R-0, HS EP4TXIF | R-0, HS EP3TXIF | R-0, HS EP2TXIF | R-0, HS EP1TXIF | R-0, HS EP0IF |
| 15:8 | R/W-0 ISOUPD | R/W-0 SOFTCONN | R/W-1 HSEN | R-0, HS HSMODE | R-0 RESET | R/W-0 RESUME | R-0, HC SUSPMODE | R/W-0 SUSPEN |
| 7:0 | U-0 — | R/W-0 | R/W-0 | R/W-0 | R/W-0 | R/W-0 | R/W-0 | R/W-0 |
| | | FUNC<6:0> | | | | | | |
| | | — | — | — | — | — | — | — |

| | | |
|-------------------|-------------------|--|
| Legend: | HS = Hardware Set | HC = Hardware Cleared |
| R = Readable bit | W = Writable bit | U = Unimplemented bit, read as '0' |
| -n = Value at POR | '1' = Bit is set | '0' = Bit is cleared x = Bit is unknown |

bit 31-24 **Unimplemented:** Read as '0'

bit 23-17 **EP7TXIF:EP1TXIF:** Endpoint 'n' TX Interrupt Flag bit
 1 = Endpoint has a transmit interrupt to be serviced
 0 = No interrupt event

bit 16 **EP0IF:** Endpoint 0 Interrupt bit
 1 = Endpoint 0 has an interrupt to be serviced
 0 = No interrupt event

All EPxTX and EP0 bits are cleared when the byte is read. Therefore, these bits must be read independently from the remaining bits in this register to avoid accidental clearing.

bit 15 **ISOUPD:** ISO Update bit (*Device mode only; unimplemented in Host mode*)
 1 = USB module will wait for a SOF token from the time TXPKTRDY is set before sending the packet
 0 = No change in behavior

This bit only affects endpoints performing isochronous transfers when in *Device mode*. This bit is unimplemented in *Host mode*.

bit 14 **SOFTCONN:** Soft Connect/Disconnect Feature Selection bit
 1 = The USB D+/D- lines are enabled and active
 0 = The USB D+/D- lines are disabled and are tri-stated

This bit is only available in *Device mode*.

bit 13 **HSEN:** Hi-Speed Enable bit
 1 = The USB module will negotiate for Hi-Speed mode when the device is reset by the hub
 0 = Module only operates in Full-Speed mode

bit 12 **HSMODE:** Hi-Speed Mode Status bit
 1 = Hi-Speed mode successfully negotiated during USB reset
 0 = Module is not in Hi-Speed mode

In *Device mode*, this bit becomes valid when a USB reset completes. In *Host mode*, it becomes valid when the RESET bit is cleared.

bit 11 **RESET:** Module Reset Status bit
 1 = Reset signaling is present on the bus
 0 = Normal module operation

In *Device mode*, this bit is read-only. In *Host mode*, this bit is read/write.

PIC32MZ Embedded Connectivity with Floating Point Unit (EF) Family

REGISTER 11-1: USBCSR0: USB CONTROL STATUS REGISTER 0 (CONTINUED)

- bit 10 **RESUME:** Resume from Suspend control bit
1 = Generate Resume signaling when the device is in Suspend mode
0 = Stop Resume signaling
- In *Device mode*, the software should clear this bit after 10 ms (a maximum of 15 ms) to end Resume signaling. In *Host mode*, the software should clear this bit after 20 ms.
- bit 9 **SUSPMODE:** Suspend Mode status bit
1 = The USB module is in Suspend mode
0 = The USB module is in Normal operations
- This bit is read-only in Device mode. In Host mode, it can be set by software, and is cleared by hardware.
- bit 8 **SUSPEN:** Suspend Mode Enable bit
1 = Suspend mode is enabled
0 = Suspend mode is not enabled
- bit 7 **Unimplemented:** Read as '0'
- bit 6-0 **FUNC<6:0>:** Device Function Address bits
- These bits are only available in *Device mode*. This field is written with the address received through a SET_ADDRESS command, which will then be used for decoding the function address in subsequent token packets.

PIC32MZ Embedded Connectivity with Floating Point Unit (EF) Family

REGISTER 11-2: USBCSR1: USB CONTROL STATUS REGISTER 1

| Bit Range | Bit 31/23/15/7 | Bit 30/22/14/6 | Bit 29/21/13/5 | Bit 28/20/12/4 | Bit 27/19/11/3 | Bit 26/18/10/2 | Bit 25/17/9/1 | Bit 24/16/8/0 |
|-----------|----------------|----------------|----------------|----------------|----------------|----------------|---------------|---------------|
| 31:24 | U-0 | U-0 | U-0 | U-0 | U-0 | U-0 | U-0 | U-0 |
| | — | — | — | — | — | — | — | — |
| 23:16 | R/W-1 | R/W-1 | R/W-1 | R/W-1 | R/W-1 | R/W-1 | R/W-1 | R/W-0 |
| | EP7TXIE | EP6TXIE | EP5TXIE | EP4TXIE | EP3TXIE | EP2TXIE | EP1TXIE | EP0IE |
| 15:8 | U-0 | U-0 | U-0 | U-0 | U-0 | U-0 | U-0 | U-0 |
| | — | — | — | — | — | — | — | — |
| 7:0 | R-0, HS | R-0, HS | R-0, HS | R-0, HS | R-0, HS | R-0, HS | R-0, HS | U-0 |
| | EP7RXIF | EP6RXIF | EP5RXIF | EP4RXIF | EP3RXIF | EP2RXIF | EP1RXIF | — |

Legend:

R = Readable bit
-n = Value at POR

W = Writable bit
'1' = Bit is set

U = Unimplemented bit, read as '0'
'0' = Bit is cleared
x = Bit is unknown

bit 31-24 **Unimplemented:** Read as '0'

bit 23-17 **EP7TXIE:EP1TXIE:** Endpoint 'n' Transmit Interrupt Enable bits
1 = Endpoint Transmit interrupt events are enabled
0 = Endpoint Transmit interrupt events are not enabled

bit 16 **EP0IE:** Endpoint 0 Interrupt Enable bit
1 = Endpoint 0 interrupt events are enabled
0 = Endpoint 0 interrupt events are not enabled

bit 15-8 **Unimplemented:** Read as '0'

bit 7-1 **EP7RXIF:EP1RXIF:** Endpoint 'n' RX Interrupt bit
1 = Endpoint has a receive event to be serviced
0 = No interrupt event

bit 0 **Unimplemented:** Read as '0'

PIC32MZ Embedded Connectivity with Floating Point Unit (EF) Family

REGISTER 11-3: USBCSR2: USB CONTROL STATUS REGISTER 2

| Bit Range | Bit 31/23/15/7 | Bit 30/22/14/6 | Bit 29/21/13/5 | Bit 28/20/12/4 | Bit 27/19/11/3 | Bit 26/18/10/2 | Bit 25/17/9/1 | Bit 24/16/8/0 |
|-----------|----------------------|---------------------|---------------------|-------------------|------------------|--------------------|---------------------|-------------------|
| 31:24 | R/W-0 VBUSERRIE | R/W-0 SESSRQIE | R/W-0 DISCONIE | R/W-0 CONNIE | R/W-0 SOFIE | R/W-1 RESETIE | R/W-1 RESUMEIE | R/W-0 SUSPIE |
| 23:16 | R-0, HS VBUSERRIF | R-0, HS SESSRQIF | R-0, HS DISCONIF | R-0, HS CONNIF | R-0, HS SOFIF | R-0, HS RESETIF | R-0, HS RESUMEIF | R-0, HS SUSPIF |
| 15:8 | U-0 — | U-0 — | U-0 — | U-0 — | U-0 — | U-0 — | U-0 — | U-0 — |
| 7:0 | R/W-1 EP7RXIE | R/W-1 EP6RXIE | R/W-1 EP5RXIE | R/W-1 EP4RXIE | R/W-1 EP3RXIE | R/W-1 EP2RXIE | R/W-1 EP1RXIE | U-0 — |

| | |
|-------------------|------------------------------------|
| Legend: | HS = Hardware Set |
| R = Readable bit | W = Writable bit |
| -n = Value at POR | '1' = Bit is set |
| | U = Unimplemented bit, read as '0' |
| | '0' = Bit is cleared |
| | x = Bit is unknown |

- bit 31 **VBUSERRIE:** VBUS Error Interrupt Enable bit
1 = VBUS error interrupt is enabled
0 = VBUS error interrupt is disabled
- bit 30 **SESSRQIE:** Session Request Interrupt Enable bit
1 = Session request interrupt is enabled
0 = Session request interrupt is disabled
- bit 29 **DISCONIE:** Device Disconnect Interrupt Enable bit
1 = Device disconnect interrupt is enabled
0 = Device disconnect interrupt is disabled
- bit 28 **CONNIE:** Device Connection Interrupt Enable bit
1 = Device connection interrupt is enabled
0 = Device connection interrupt is disabled
- bit 27 **SOFIE:** Start of Frame Interrupt Enable bit
1 = Start of Frame event interrupt is enabled
0 = Start of Frame event interrupt is disabled
- bit 26 **RESETIE:** Reset/Babble Interrupt Enable bit
1 = Interrupt when reset (*Device mode*) or Babble (*Host mode*) is enabled
0 = Reset/Babble interrupt is disabled
- bit 25 **RESUMEIE:** Resume Interrupt Enable bit
1 = Resume signaling interrupt is enabled
0 = Resume signaling interrupt is disabled
- bit 24 **SUSPIE:** Suspend Interrupt Enable bit
1 = Suspend signaling interrupt is enabled
0 = Suspend signaling interrupt is disabled
- bit 23 **VBUSERRIF:** VBUS Error Interrupt bit
1 = VBUS has dropped below the VBUS valid threshold during a session
0 = No interrupt
- bit 22 **SESSRQIF:** Session Request Interrupt bit
1 = Session request signaling has been detected
0 = No session request detected
- bit 21 **DISCONIF:** Device Disconnect Interrupt bit
1 = In *Host mode*, indicates when a device disconnect is detected. In *Device mode*, indicates when a session ends.
0 = No device disconnect detected
- bit 20 **CONNIF:** Device Connection Interrupt bit
1 = In *Host mode*, indicates when a device connection is detected
0 = No device connection detected

PIC32MZ Embedded Connectivity with Floating Point Unit (EF) Family

REGISTER 11-3: USBCSR2: USB CONTROL STATUS REGISTER 2 (CONTINUED)

- bit 19 **SOFIF:** Start of Frame Interrupt bit
1 = A new frame has started
0 = No start of frame detected
- bit 18 **RESETIF:** Reset/Babble Interrupt bit
1 = In *Host mode*, indicates babble is detected. In *Device mode*, indicates reset signaling is detected on the bus.
0 = No reset/babble detected
- bit 17 **RESUMEIF:** Resume Interrupt bit
1 = Resume signaling is detected on the bus while USB module is in Suspend mode
0 = No Resume signaling detected
- bit 16 **SUSPIF:** Suspend Interrupt bit
1 = Suspend signaling is detected on the bus (*Device mode*)
0 = No suspend signaling detected
- bit 15-8 **Unimplemented:** Read as '0'
- bit 7-1 **EP7RXIE:EP1RXIE:** Endpoint 'n' Receive Interrupt Enable bit
1 = Receive interrupt is enabled for this endpoint
0 = Receive interrupt is not enabled
- bit 0 **Unimplemented:** Read as '0'

PIC32MZ Embedded Connectivity with Floating Point Unit (EF) Family

REGISTER 11-4: USBCSR3: USB CONTROL STATUS REGISTER 3

| Bit Range | Bit 31/23/15/7 | Bit 30/22/14/6 | Bit 29/21/13/5 | Bit 28/20/12/4 | Bit 27/19/11/3 | Bit 26/18/10/2 | Bit 25/17/9/1 | Bit 24/16/8/0 |
|-----------|----------------|----------------|----------------|----------------|----------------|----------------|---------------|---------------|
| 31:24 | R/W-0 | R/W-0, HC | R/W-0 | R/W-0 | R/W-0 | R/W-0 | R/W-0 | R/W-0 |
| | FORCEHST | FIFOACC | FORCEFS | FORCEHS | PACKET | TESTK | TESTJ | NAK |
| 23:16 | U-0 | U-0 | U-0 | U-0 | R/W-0 | R/W-0 | R/W-0 | R/W-0 |
| | — | — | — | — | ENDPOINT<3:0> | | | |
| 15:8 | U-0 | U-0 | U-0 | U-0 | U-0 | R-0 | R-0 | R-0 |
| | — | — | — | — | — | RFRMUM<10:8> | | |
| 7:0 | R-0 | R-0 | R-0 | R-0 | R-0 | R-0 | R-0 | R-0 |
| | RFRMNUM<7:0> | | | | | | | |

| | |
|-------------------|------------------------------------|
| Legend: | HC = Hardware Cleared |
| R = Readable bit | W = Writable bit |
| -n = Value at POR | '1' = Bit is set |
| | U = Unimplemented bit, read as '0' |
| | '0' = Bit is cleared |
| | x = Bit is unknown |

- bit 31 **FORCEHST:** Test Mode Force Host Select bit
1 = Forces USB module into *Host mode*, regardless of whether it is connected to any peripheral
0 = Normal operation
- bit 30 **FIFOACC:** Test Mode Endpoint 0 FIFO Transfer Force bit
1 = Transfers the packet in the Endpoint 0 TX FIFO to the Endpoint 0 RX FIFO
0 = No transfer
- bit 29 **FORCEFS:** Test mode Force Full-Speed Mode Select bit
This bit is only active if FORCEHST = 1.
1 = Forces USB module into Full-Speed mode. Undefined behavior if FORCEHS = 1.
0 = If FORCEHS = 0, places USB module into Low-Speed mode.
- bit 28 **FORCEHS:** Test mode Force Hi-Speed Mode Select bit
This bit is only active if FORCEHST = 1.
1 = Forces USB module into Hi-Speed mode. Undefined behavior if FORCEFS = 1.
0 = If FORCEFS = 0, places USB module into Low-Speed mode.
- bit 27 **PACKET:** Test_Packet Test Mode Select bit
This bit is only active if module is in Hi-Speed mode.
1 = The USB module repetitively transmits on the bus a 53-byte test packet. Test packet must be loaded into the Endpoint 0 FIFO before the test mode is entered.
0 = Normal operation
- bit 26 **TESTK:** Test_K Test Mode Select bit
1 = Enters Test_K test mode. The USB module transmits a continuous K on the bus.
0 = Normal operation
This bit is only active if the USB module is in Hi-Speed mode.
- bit 25 **TESTJ:** Test_J Test Mode Select bit
1 = Enters Test_J test mode. The USB module transmits a continuous J on the bus.
0 = Normal operation
This bit is only active if the USB module is in Hi-Speed mode.
- bit 24 **NAK:** Test_SE0_NAK Test Mode Select bit
1 = Enter Test_SE0_NAK test mode. The USB module remains in Hi-Speed mode but responds to any valid IN token with a NAK
0 = Normal operation
This mode is only active if module is in Hi-Speed mode.
- bit 23-20 **Unimplemented:** Read as '0'

PIC32MZ Embedded Connectivity with Floating Point Unit (EF) Family

REGISTER 11-4: USBCSR3: USB CONTROL STATUS REGISTER 3 (CONTINUED)

bit 19-16 **ENDPOINT<3:0>**: Endpoint Registers Select bits

1111 = Reserved

•

•

•

1000 = Reserved

0111 = Endpoint 7

•

•

•

0000 = Endpoint 0

These bits select which endpoint registers are accessed through addresses 3010-301F.

bit 15-11 **Unimplemented**: Read as '0'

bit 10-0 **RFRMNUM<10:0>**: Last Received Frame Number bits

PIC32MZ Embedded Connectivity with Floating Point Unit (EF) Family

REGISTER 11-5: USBIE0CSR0: USB INDEXED ENDPOINT CONTROL STATUS REGISTER 0 (ENDPOINT 0)

| Bit Range | Bit 31/23/15/7 | Bit 30/22/14/6 | Bit 29/21/13/5 | Bit 28/20/12/4 | Bit 27/19/11/3 | Bit 26/18/10/2 | Bit 25/17/9/1 | Bit 24/16/8/0 |
|-----------|----------------|----------------|----------------|----------------|----------------|----------------|---------------|---------------|
| 31:24 | U-0 | U-0 | U-0 | U-0 | R/W-0 | R/W-0, HC | R/W-0 | R/W-0, HC |
| | — | — | — | — | DISPING | DTWREN | DATATGGL | FLSHFIFO |
| 23:16 | R/W-0, HC | R/W-0, HC | R/W-0, HC | R/C-0, HS | R/W-0, HS | R-0, HS | R-0 | R-0 |
| | SVCSETEND | SVCRPR | SENDSTALL | SETUPEND | DATAEND | SENTSTALL | TXPKTRDY | RXPKTRDY |
| 15:8 | U-0 | U-0 | U-0 | U-0 | U-0 | U-0 | U-0 | U-0 |
| | — | — | — | — | — | — | — | — |
| 7:0 | U-0 | U-0 | U-0 | U-0 | U-0 | U-0 | U-0 | U-0 |
| | — | — | — | — | — | — | — | — |

| | | |
|-------------------|-----------------------|--|
| Legend: | HC = Hardware Cleared | HS = Hardware Set |
| R = Readable bit | W = Writable bit | U = Unimplemented bit, read as '0' |
| -n = Value at POR | '1' = Bit is set | '0' = Bit is cleared x = Bit is unknown |

bit 31-28 **Unimplemented:** Read as '0'

bit 27 **DISPING:** Disable Ping tokens control bit (*Host mode*)
 1 = USB Module will not issue PING tokens in data and status phases of a Hi-Speed Control transfer
 0 = Ping tokens are issued

bit 26 **DTWREN:** Data Toggle Write Enable bit (*Host mode*)
 1 = Enable the current state of the Endpoint 0 data toggle to be written. Automatically cleared.
 0 = Disable data toggle write

bit 25 **DATATGGL:** Data Toggle bit (*Host mode*)
 When read, this bit indicates the current state of the Endpoint 0 data toggle.
 If DTWREN = 1, this bit is writable with the desired setting.
 If DTWREN = 0, this bit is read-only.

bit 24 **FLSHFIFO:** Flush FIFO Control bit
 1 = Flush the next packet to be transmitted/read from the Endpoint 0 FIFO. The FIFO pointer is reset and the TXPKTRDY/RXPKTRDY bit is cleared. Automatically cleared when the operation completes. Should only be used when TXPKTRDY/RXPKTRDY = 1.
 0 = No Flush operation

bit 23 **SVCSETEND:** Clear SETUPEND Control bit (*Device mode*)
 1 = Clear the SETUPEND bit in this register. This bit is automatically cleared.
 0 = Do not clear

NAKTMOUT: NAK Time-out Control bit (*Host mode*)
 1 = Endpoint 0 is halted following the receipt of NAK responses for longer than the time set by the NAKLIM<4:0> bits (USBICSR<28:24>)
 0 = Allow the endpoint to continue

bit 22 **SVCRPR:** Serviced RXPKTRDY Clear Control bit (*Device mode*)
 1 = Clear the RXPKTRDY bit in this register. This bit is automatically cleared.
 0 = Do not clear

STATPKT: Status Stage Transaction Control bit (*Host mode*)
 1 = When set at the same time as the TXPKTRDY or REQPKT bit is set, performs a status stage transaction
 0 = Do not perform a status stage transaction

PIC32MZ Embedded Connectivity with Floating Point Unit (EF) Family

REGISTER 11-5: USBIE0CSR0: USB INDEXED ENDPOINT CONTROL STATUS REGISTER 0 (ENDPOINT 0) (CONTINUED)

- bit 21 **SENDSTALL:** Send Stall Control bit (*Device mode*)
1 = Terminate the current transaction and transmit a STALL handshake. This bit is automatically cleared.
0 = Do not send STALL handshake.
- REQPKT:** IN transaction Request Control bit (*Host mode*)
1 = Request an IN transaction. This bit is cleared when the RXPKTRDY bit is set.
0 = Do not request an IN transaction
- bit 20 **SETUPEND:** Early Control Transaction End Status bit (*Device mode*)
1 = A control transaction ended before the DATAEND bit has been set. An interrupt will be generated and the FIFO flushed at this time.
0 = Normal operation
This bit is cleared by writing a '1' to the SVCSETEND bit in this register.
- ERROR:** No Response Error Status bit (*Host mode*)
1 = Three attempts have been made to perform a transaction with no response from the peripheral. An interrupt is generated.
0 = Clear this flag. Software must write a '0' to this bit to clear it.
- bit 19 **DATAEND:** End of Data Control bit (*Device mode*)
The software sets this bit when:
- Setting TXPKTRDY for the last data packet
 - Clearing RXPKTRDY after unloading the last data packet
 - Setting TXPKTRDY for a zero length data packet
- Hardware clears this bit.
- SETUPPKT:** Send a SETUP token Control bit (*Host mode*)
1 = When set at the same time as the TXPKTRDY bit is set, the module sends a SETUP token instead of an OUT token for the transaction
0 = Normal OUT token operation
Setting this bit also clears the Data Toggle.
- bit 18 **SENTSTALL:** STALL sent status bit (*Device mode*)
1 = STALL handshake has been transmitted
0 = Software clear of bit
- RXSTALL:** STALL handshake received Status bit (*Host mode*)
1 = STALL handshake was received
0 = Software clear of bit
- bit 17 **TXPKTRDY:** TX Packet Ready Control bit
1 = Data packet has been loaded into the FIFO. It is cleared automatically.
0 = No data packet is ready for transmit
- bit 16 **RXPKTRDY:** RX Packet Ready Status bit
1 = Data packet has been received. Interrupt is generated (when enabled) when this bit is set.
0 = No data packet has been received
This bit is cleared by setting the SVCRRPR bit.
- bit 15-0 **Unimplemented:** Read as '0'

PIC32MZ Embedded Connectivity with Floating Point Unit (EF) Family

REGISTER 11-6: USBIE0CSR2: USB INDEXED ENDPOINT CONTROL STATUS REGISTER 2 (ENDPOINT 0)

| Bit Range | Bit 31/23/15/7 | Bit 30/22/14/6 | Bit 29/21/13/5 | Bit 28/20/12/4 | Bit 27/19/11/3 | Bit 26/18/10/2 | Bit 25/17/9/1 | Bit 24/16/8/0 |
|-----------|----------------|----------------|----------------|----------------|----------------|----------------|---------------|---------------|
| 31:24 | U-0 | U-0 | U-0 | R/W-0 | R/W-0 | R/W-0 | R/W-0 | R/W-0 |
| | — | — | — | NAKLIM<4:0> | | | | |
| 23:16 | R/W-0 | R/W-0 | U-0 | U-0 | U-0 | U-0 | U-0 | U-0 |
| | SPEED<1:0> | | | — | — | — | — | — |
| 15:8 | U-0 | U-0 | U-0 | U-0 | U-0 | U-0 | U-0 | U-0 |
| | — | — | — | — | — | — | — | — |
| 7:0 | U-0 | R-0 | R-0 | R-0 | R-0 | R-0 | R-0 | R-0 |
| | — | RXCNT<6:0> | | | | | | |

Legend:

R = Readable bit
-n = Value at POR

W = Writable bit
'1' = Bit is set

U = Unimplemented bit, read as '0'
'0' = Bit is cleared
x = Bit is unknown

bit 31-29 **Unimplemented:** Read as '0'

bit 28-24 **NAKLIM<4:0>:** Endpoint 0 NAK Limit bits

The number of frames/microframes (Hi-Speed transfers) after which Endpoint 0 should time-out on receiving a stream of NAK responses.

bit 23-22 **SPEED<1:0>:** Operating Speed Control bits

11 = Low-Speed
10 = Full-Speed
01 = Hi-Speed
00 = Reserved

bit 21-7 **Unimplemented:** Read as '0'

bit 6-0 **RXCNT<6:0>:** Receive Count bits

The number of received data bytes in the Endpoint 0 FIFO. The value returned changes as the contents of the FIFO change and is only valid while RXPKTRDY is set.

PIC32MZ Embedded Connectivity with Floating Point Unit (EF) Family

REGISTER 11-7: USBIE0CSR3: USB INDEXED ENDPOINT CONTROL STATUS REGISTER 3 (ENDPOINT 0)

| Bit Range | Bit 31/23/15/7 | Bit 30/22/14/6 | Bit 29/21/13/5 | Bit 28/20/12/4 | Bit 27/19/11/3 | Bit 26/18/10/2 | Bit 25/17/9/1 | Bit 24/16/8/0 |
|-----------|----------------|----------------|----------------|----------------|----------------|----------------|---------------|---------------|
| 31:24 | R-x | R-x | R-0 | R-x | R-x | R-x | R-1 | R-0 |
| | MPRXEN | MPTXEN | BIGEND | HBRXEN | HBTXEN | DYNFIFOS | SOFTCONE | UTMIDWID |
| 23:16 | U-0 | U-0 | U-0 | U-0 | U-0 | U-0 | U-0 | U-0 |
| | — | — | — | — | — | — | — | — |
| 15:8 | U-0 | U-0 | U-0 | U-0 | U-0 | U-0 | U-0 | U-0 |
| | — | — | — | — | — | — | — | — |
| 7:0 | U-0 | U-0 | U-0 | U-0 | U-0 | U-0 | U-0 | U-0 |
| | — | — | — | — | — | — | — | — |

Legend:

R = Readable bit W = Writable bit U = Unimplemented bit, read as '0'
 -n = Value at POR '1' = Bit is set '0' = Bit is cleared x = Bit is unknown

- bit 31 **MPRXEN:** Automatic Amalgamation Option bit
 1 = Automatic amalgamation of bulk packets is done
 0 = No automatic amalgamation
- bit 30 **MPTXEN:** Automatic Splitting Option bit
 1 = Automatic splitting of bulk packets is done
 0 = No automatic splitting
- bit 29 **BIGEND:** Byte Ordering Option bit
 1 = Big Endian ordering
 0 = Little Endian ordering
- bit 28 **HBRXEN:** High-bandwidth RX ISO Option bit
 1 = High-bandwidth RX ISO endpoint support is selected
 0 = No High-bandwidth RX ISO support
- bit 27 **HBTXEN:** High-bandwidth TX ISO Option bit
 1 = High-bandwidth TX ISO endpoint support is selected
 0 = No High-bandwidth TX ISO support
- bit 26 **DYNFIFOS:** Dynamic FIFO Sizing Option bit
 1 = Dynamic FIFO sizing is supported
 0 = No Dynamic FIFO sizing
- bit 25 **SOFTCONE:** Soft Connect/Disconnect Option bit
 1 = Soft Connect/Disconnect is supported
 0 = Soft Connect/Disconnect is not supported
- bit 24 **UTMIDWID:** UTMI+ Data Width Option bit
 Always '0', indicating 8-bit UTMI+ data width
- bit 23-0 **Unimplemented:** Read as '0'

PIC32MZ Embedded Connectivity with Floating Point Unit (EF) Family

REGISTER 11-8: USBIENCSR0: USB INDEXED ENDPOINT CONTROL STATUS REGISTER 0 (ENDPOINT 1-7)

| Bit Range | Bit 31/23/15/7 | Bit 30/22/14/6 | Bit 29/21/13/5 | Bit 28/20/12/4 | Bit 27/19/11/3 | Bit 26/18/10/2 | Bit 25/17/9/1 | Bit 24/16/8/0 |
|-------------|----------------|----------------|----------------|----------------|----------------|----------------|---------------|---------------|
| 31:24 | R/W-0 | R/W-0 | R/W-0 | R/W-0 | R/W-0 | R/W-0 | R/W-0 | R/W-0 |
| | AUTOSET | ISO — | MODE | DMAREQEN | FRCDATTG | DMAREQMD | — DATAWEN | — DATATGGL |
| 23:16 | R/W-0, HS | R/W-0, HC | R/W-0, HS | R/W-0 | R/W-0 | R/W-0, HS | R/W-0 | R/W-0, HC |
| | INCOMPTX | CLRDT | SENTSTALL | SENDSTALL | FLUSH | UNDERRUN | FIFONE | TXPKTRDY |
| | NAKTMOUT | | RXSTALL | SETUPPKT | | ERROR | | |
| 15:8 | R/W-0 | R/W-0 | R/W-0 | R/W-0 | R/W-0 | R/W-0 | R/W-0 | R/W-0 |
| MULT<4:0> | | | | | | TXMAXP<10:8> | | |
| 7:0 | R/W-0 | R/W-0 | R/W-0 | R/W-0 | R/W-0 | R/W-0 | R/W-0 | R/W-0 |
| TXMAXP<7:0> | | | | | | | | |

Legend:

R = Readable bit W = Writable bit U = Unimplemented bit, read as '0'
-n = Value at POR '1' = Bit is set '0' = Bit is cleared x = Bit is unknown

- bit 31 **AUTOSET:** Auto Set Control bit
1 = TXPKTRDY will be automatically set when data of the maximum packet size (value in TXMAXP) is loaded into the TX FIFO. If a packet of less than the maximum packet size is loaded, then TXPKTRDY will have to be set manually.
0 = TXPKTRDY must be set manually for all packet sizes
- bit 30 **ISO:** Isochronous TX Endpoint Enable bit (Device mode)
1 = Enables the endpoint for Isochronous transfers
0 = Disables the endpoint for Isochronous transfers and enables it for Bulk or Interrupt transfers.
This bit only has an effect in Device mode. In Host mode, it always returns zero.
- bit 29 **MODE:** Endpoint Direction Control bit
1 = Endpoint is TX
0 = Endpoint is RX
This bit only has any effect where the same endpoint FIFO is used for both TX and RX transactions.
- bit 28 **DMAREQEN:** Endpoint DMA Request Enable bit
1 = DMA requests are enabled for this endpoint
0 = DMA requests are disabled for this endpoint
- bit 27 **FRCDATTG:** Force Endpoint Data Toggle Control bit
1 = Forces the endpoint data toggle to switch and the data packet to be cleared from the FIFO, regardless of whether an ACK was received.
0 = No forced behavior
- bit 26 **DMAREQMD:** Endpoint DMA Request Mode Control bit
1 = DMA Request Mode 1
0 = DMA Request Mode 0
This bit must not be cleared either before or in the same cycle as the above DMAREQEN bit is cleared.
- bit 25 **DATAWEN:** Data Toggle Write Enable bit (Host mode)
1 = Enable the current state of the TX Endpoint data toggle (DATATGGL) to be written
0 = Disables writing the DATATGGL bit
- bit 24 **DATATGGL:** Data Toggle Control bit (Host mode)
When read, this bit indicates the current state of the TX Endpoint data toggle. If DATAWEN = 1, this bit may be written with the required setting of the data toggle. If DATAWEN = 0, any value written to this bit is ignored.

PIC32MZ Embedded Connectivity with Floating Point Unit (EF) Family

REGISTER 11-8: USBIENCSR0: USB INDEXED ENDPOINT CONTROL STATUS REGISTER 0 (ENDPOINT 1-7) (CONTINUED)

- bit 23 **INCOMPTX:** Incomplete TX Status bit (Device mode)
1 = For high-bandwidth Isochronous endpoint, a large packet has been split into 2 or 3 packets for transmission but insufficient IN tokens have been received to send all the parts
0 = Normal operation
In anything other than isochronous transfers, this bit will always return 0.
- NAKTMOUT:** NAK Time-out status bit (Host mode)
1 = TX endpoint is halted following the receipt of NAK responses for longer than the NAKLIM setting
0 = Written by software to clear this bit
- bit 22 **CLRDT:** Clear Data Toggle Control bit
1 = Resets the endpoint data toggle to 0
0 = Do not clear the data toggle
- bit 21 **SENTSTALL:** STALL handshake transmission status bit (Device mode)
1 = STALL handshake is transmitted. The FIFO is flushed and the TXPKTRDY bit is cleared.
0 = Written by software to clear this bit
- RXSTALL:** STALL receipt bit (Host mode)
1 = STALL handshake is received. Any DMA request in progress is stopped, the FIFO is completely flushed and the TXPKTRDY bit is cleared.
0 = Written by software to clear this bit
- bit 20 **SENDSTALL:** STALL handshake transmission control bit (Device mode)
1 = Issue a STALL handshake to an IN token
0 = Terminate stall condition
This bit has no effect when the endpoint is being used for Isochronous transfers.
- SETUPPKT:** Definition bit (Host mode)
1 = When set at the same time as the TXPKTRDY bit is set, send a SETUP token instead of an OUT token for the transaction. This also clears the Data Toggle.
0 = Normal OUT token for the transaction
- bit 19 **FLUSH:** FIFO Flush control bit
1 = Flush the latest packet from the endpoint TX FIFO. The FIFO pointer is reset, TXPKTRDY is cleared and an interrupt is generated.
0 = Do not flush the FIFO
- bit 18 **UNDERRUN:** Underrun status bit (Device mode)
1 = An IN token has been received when TXPKTRDY is not set.
0 = Written by software to clear this bit.
- ERROR:** Handshake failure status bit (Host mode)
1 = Three attempts have been made to send a packet and no handshake packet has been received
0 = Written by software to clear this bit.
- bit 17 **FIFONE:** FIFO Not Empty status bit
1 = There is at least 1 packet in the TX FIFO
0 = TX FIFO is empty
- bit 16 **TXPKTRDY:** TX Packet Ready Control bit
The software sets this bit after loading a data packet into the FIFO. It is cleared automatically when a data packet has been transmitted. This bit is also automatically cleared prior to loading a second packet into a double-buffered FIFO.

PIC32MZ Embedded Connectivity with Floating Point Unit (EF) Family

REGISTER 11-8: USBIENCSR0: USB INDEXED ENDPOINT CONTROL STATUS REGISTER 0 (ENDPOINT 1-7) (CONTINUED)

bit 15-11 **MULT<4:0>**: Multiplier Control bits

For Isochronous/Interrupt endpoints or of packet splitting on Bulk endpoints, multiplies TXMAXP by MULT+1 for the payload size.

For Bulk endpoints, MULT can be up to 32 and defines the number of "USB" packets of the specified payload into which a single data packet placed in the FIFO should be split, prior to transfer. The data packet is required to be an exact multiple of the payload specified by TXMAXP.

For Isochronous/Interrupts endpoints operating in Hi-Speed mode, MULT may be either 2 or 3 and specifies the maximum number of such transactions that can take place in a single microframe.

bit 10-0 **TXMAXP<10:0>**: Maximum TX Payload per transaction Control bits

This field sets the maximum payload (in bytes) transmitted in a single transaction. The value is subject to the constraints placed by the USB Specification on packet sizes for Bulk, Interrupt and Isochronous transfers in Full-Speed and Hi-Speed operations.

TXMAXP must be set to an even number of bytes for proper interrupt generation in DMA Mode 1.

PIC32MZ Embedded Connectivity with Floating Point Unit (EF) Family

REGISTER 11-9: USBIENCSR1: USB INDEXED ENDPOINT CONTROL STATUS REGISTER 1 (ENDPOINT 1-7)

| Bit Range | Bit 31/23/15/7 | Bit 30/22/14/6 | Bit 29/21/13/5 | Bit 28/20/12/4 | Bit 27/19/11/3 | Bit 26/18/10/2 | Bit 25/17/9/1 | Bit 24/16/8/0 |
|-----------|----------------|----------------|----------------|----------------|----------------|----------------|---------------|---------------|
| 31:24 | R/W-0 | R/W-0 | R/W-0 | R/W-0 | R/W-0 | R/W-0, HC | R-0 | R/W-0 |
| | AUTOCLR | ISO | DMAREQEN | DISNYET | DMAREQMD | — | — | INCOMPRX |
| AUTORQ | | PIDERR | | DATATWEN | | DATATGGL | | |
| 23:16 | R/W-0, HC | R/W-0, HS | R/W-0 | R/W-0, HC | R-0, HS | R/W-0, HS | R-0, HS, HC | R/W-0, HS |
| | CLRDT | SENTSTALL | SENDSTALL | FLUSH | DATAERR | OVERRUN | FIFOFULL | RXPKTRDY |
| RXSTALL | | REQPKT | DERRNAKT | | ERROR | | | |
| 15:8 | R/W-0 | R/W-0 | R/W-0 | R/W-0 | R/W-0 | R/W-0 | R/W-0 | R/W-0 |
| | MULT<4:0> | | | | | RXMAXP<10:8> | | |
| 7:0 | R/W-0 | R/W-0 | R/W-0 | R/W-0 | R/W-0 | R/W-0 | R/W-0 | R/W-0 |
| | RXMAXP<7:0> | | | | | | | |

| | | |
|-------------------|-----------------------|------------------------------------|
| Legend: | HC = Hardware Cleared | HS = Hardware Set |
| R = Readable bit | W = Writable bit | U = Unimplemented bit, read as '0' |
| -n = Value at POR | '1' = Bit is set | '0' = Bit is cleared |
| | | x = Bit is unknown |

bit 31 **AUTOCLR:** RXPKTRDY Automatic Clear Control bit

- 1 = RXPKTRDY will be automatically cleared when a packet of RXMAXP bytes has been unloaded from the RX FIFO. When packets of less than the maximum packet size are unloaded, RXPKTRDY will have to be cleared manually. When using a DMA to unload the RX FIFO, data is read from the RX FIFO in 4-byte chunks regardless of the RXMAXP.
- 0 = No automatic clearing of RXPKTRDY

This bit should not be set for high-bandwidth Isochronous endpoints.

bit 30 **ISO:** Isochronous Endpoint Control bit (*Device mode*)

- 1 = Enable the RX endpoint for Isochronous transfers
- 0 = Enable the RX endpoint for Bulk/Interrupt transfers

AUTORQ: Automatic Packet Request Control bit (*Host mode*)

- 1 = REQPKT will be automatically set when RXPKTRDY bit is cleared.
- 0 = No automatic packet request

This bit is automatically cleared when a short packet is received.

bit 29 **DMAREQEN:** DMA Request Enable Control bit

- 1 = Enable DMA requests for the RX endpoint.
- 0 = Disable DMA requests for the RX endpoint.

bit 28 **DISNYET:** Disable NYET Handshakes Control/PID Error Status bit (*Device mode*)

- 1 = In Bulk/Interrupt transactions, disables the sending of NYET handshakes. All successfully received RX packets are ACKed including at the point at which the FIFO becomes full.
- 0 = Normal operation.

In Bulk/Interrupt transactions, this bit only has any effect in Hi-Speed mode, in which mode it should be set for all Interrupt endpoints.

PIDERR: PID Error Status bit (*Host mode*)

- 1 = In ISO transactions, this indicates a PID error in the received packet.
- 0 = No error

bit 27 **DMAREQMD:** DMA Request Mode Selection bit

- 1 = DMA Request Mode 1
- 0 = DMA Request Mode 0

PIC32MZ Embedded Connectivity with Floating Point Unit (EF) Family

REGISTER 11-9: USBIENCSR1: USB INDEXED ENDPOINT CONTROL STATUS REGISTER 1 (ENDPOINT 1-7) (CONTINUED)

- bit 26 **DATATWEN:** Data Toggle Write Enable Control bit (*Host mode*)
1 = DATATGGL can be written
0 = DATATGGL is not writable
- bit 25 **DATATGGL:** Data Toggle bit (*Host mode*)
When read, this bit indicates the current state of the endpoint data toggle.
If DATATWEN = 1, this bit may be written with the required setting of the data toggle.
If DATATWEN = 0, any value written to this bit is ignored.
- bit 24 **INCOMPRX:** Incomplete Packet Status bit
1 = The packet in the RX FIFO during a high-bandwidth Isochronous/Interrupt transfer is incomplete because parts of the data were not received
0 = Written by then software to clear this bit
In anything other than Isochronous transfer, this bit will always return 0.
- bit 23 **CLRDT:** Clear Data Toggle Control bit
1 = Reset the endpoint data toggle to 0
0 = Leave endpoint data toggle alone
- bit 22 **SENTSTALL:** STALL Handshake Status bit (*Device mode*)
1 = STALL handshake is transmitted
0 = Written by the software to clear this bit
- RXSTALL:** STALL Handshake Receive Status bit (*Host mode*)
1 = A STALL handshake has been received. An interrupt is generated.
0 = Written by the software to clear this bit
- bit 21 **SENDSTALL:** STALL Handshake Control bit (*Device mode*)
1 = Issue a STALL handshake
0 = Terminate stall condition
- REQPKT:** IN Transaction Request Control bit (*Host mode*)
1 = Request an IN transaction.
0 = No request
This bit is cleared when RXPKTRDY is set.
- bit 20 **FLUSH:** Flush FIFO Control bit
1 = Flush the next packet to be read from the endpoint RX FIFO. The FIFO pointer is reset and the RXPKTRDY bit is cleared. This should only be used when RXPKTRDY is set. If the FIFO is double-buffered, FLUSH may need to be set twice to completely clear the FIFO.
0 = Normal FIFO operation
This bit is automatically cleared.
- bit 19 **DATAERR:** Data Packet Error Status bit (*Device mode*)
1 = The data packet has a CRC or bit-stuff error.
0 = No data error
This bit is cleared when RXPKTRDY is cleared. This bit is only valid when the endpoint is operating in ISO mode. In Bulk mode, it always returns zero.
- DERRNAKT:** Data Error/NAK Time-out Status bit (*Host mode*)
1 = The data packet has a CRC or bit-stuff error. In Bulk mode, the RX endpoint is halted following the receipt of NAK responses for longer than the time set as the NAK limit.
0 = No data or NAK time-out error

PIC32MZ Embedded Connectivity with Floating Point Unit (EF) Family

REGISTER 11-9: USBIENCSR1: USB INDEXED ENDPOINT CONTROL STATUS REGISTER 1 (ENDPOINT 1-7) (CONTINUED)

- bit 18 **OVERRUN:** Data Overrun Status bit (*Device mode*)
- 1 = An OUT packet cannot be loaded into the RX FIFO.
 - 0 = Written by software to clear this bit
- This bit is only valid when the endpoint is operating in ISO mode. In Bulk mode, it always returns zero.
- ERROR:** No Data Packet Received Status bit (*Host mode*)
- 1 = Three attempts have been made to receive a packet and no data packet has been received. An interrupt is generated.
 - 0 = Written by the software to clear this bit.
- This bit is only valid when the RX endpoint is operating in Bulk or Interrupt mode. In ISO mode, it always returns zero.
- bit 17 **FIFOFULL:** FIFO Full Status bit
- 1 = No more packets can be loaded into the RX FIFO
 - 0 = The RX FIFO has at least one free space
- bit 16 **RXPKTRDY:** Data Packet Reception Status bit
- 1 = A data packet has been received. An interrupt is generated.
 - 0 = Written by software to clear this bit when the packet has been unloaded from the RX FIFO.
- bit 15-11 **MULT<4:0>:** Multiplier Control bits
- For Isochronous/Interrupt endpoints or of packet splitting on Bulk endpoints, multiplies TXMAXP by MULT+1 for the payload size.
- For Bulk endpoints, MULT can be up to 32 and defines the number of “USB” packets of the specified payload into which a single data packet placed in the FIFO should be split, prior to transfer. The data packet is required to be an exact multiple of the payload specified by TXMAXP.
- For Isochronous/Interrupts endpoints operating in Hi-Speed mode, MULT may be either 2 or 3 and specifies the maximum number of such transactions that can take place in a single microframe.
- bit 10-0 **RXMAXP<10:0>:** Maximum RX Payload Per Transaction Control bits
- This field sets the maximum payload (in bytes) transmitted in a single transaction. The value is subject to the constraints placed by the USB Specification on packet sizes for Bulk, Interrupt and Isochronous transfers in Full-Speed and Hi-Speed operations.
- RXMAXP must be set to an even number of bytes for proper interrupt generation in DMA Mode 1.

PIC32MZ Embedded Connectivity with Floating Point Unit (EF) Family

REGISTER 11-10: USBIENCSR2: USB INDEXED ENDPOINT CONTROL STATUS REGISTER 2 (ENDPOINT 1-7)

| Bit Range | Bit 31/23/15/7 | Bit 30/22/14/6 | Bit 29/21/13/5 | Bit 28/20/12/4 | Bit 27/19/11/3 | Bit 26/18/10/2 | Bit 25/17/9/1 | Bit 24/16/8/0 |
|---------------|----------------|----------------|----------------|----------------|----------------|----------------|---------------|---------------|
| 31:24 | R/W-0 | R/W-0 | R/W-0 | R/W-0 | R/W-0 | R/W-0 | R/W-0 | R/W-0 |
| TXINTERV<7:0> | | | | | | | | |
| 23:16 | R/W-0 | R/W-0 | R/W-0 | R/W-0 | R/W-0 | R/W-0 | R/W-0 | R/W-0 |
| SPEED<1:0> | | PROTOCOL<1:0> | | | TEP<3:0> | | | |
| 15:8 | U-0 | U-0 | R-0 | R-0 | R-0 | R-0 | R-0 | R-0 |
| RXCNT<13:8> | | | | | | | | |
| 7:0 | R-0 | R-0 | R-0 | R-0 | R-0 | R-0 | R-0 | R-0 |
| RXCNT<7:0> | | | | | | | | |

| | | |
|-------------------|-----------------------|--|
| Legend: | HC = Hardware Cleared | HS = Hardware Set |
| R = Readable bit | W = Writable bit | U = Unimplemented bit, read as '0' |
| -n = Value at POR | '1' = Bit is set | '0' = Bit is cleared x = Bit is unknown |

bit 31-24 **TXINTERV<7:0>**: Endpoint TX Polling Interval/NAK Limit bits (*Host mode*)

For Interrupt and Isochronous transfers, this field defines the polling interval for the endpoint. For Bulk endpoints, this field sets the number of frames/microframes after which the endpoint should time out on receiving a stream of NAK responses.

The following table describes the valid values and interpretation for these bits:

| Transfer Type | Speed | Valid Values (m) | Interpretation |
|---------------|--------------|------------------|--|
| Interrupt | Low/Full | 0x01 to 0xFF | Polling interval is 'm' frames. |
| | High | 0x01 to 0x10 | Polling interval is $2^{(m-1)}$ frames. |
| Isochronous | Full or High | 0x01 to 0x10 | Polling interval is $2^{(m-1)}$ frames/microframes. |
| Bulk | Full or High | 0x02 to 0x10 | NAK limit is $2^{(m-1)}$ frames/microframes. A value of '0' or '1' disables the NAK time-out function. |

bit 23-22 **SPEED<1:0>**: TX Endpoint Operating Speed Control bits (*Host mode*)

- 11 = Low-Speed
- 10 = Full-Speed
- 01 = Hi-Speed
- 00 = Reserved

bit 21-20 **PROTOCOL<1:0>**: TX Endpoint Protocol Control bits

- 11 = Interrupt
- 10 = Bulk
- 01 = Isochronous
- 00 = Control

bit 19-16 **TEP<3:0>**: TX Target Endpoint Number bits

This value is the endpoint number contained in the TX endpoint descriptor returned to the USB module during device enumeration.

bit 15-14 **Unimplemented**: Read as '0'

bit 13-0 **RXCNT<13:0>**: Receive Count bits

The number of received data bytes in the endpoint RX FIFO. The value returned changes as the contents of the FIFO change and is only valid while RXPKTRDY is set.

PIC32MZ Embedded Connectivity with Floating Point Unit (EF) Family

REGISTER 11-11: USBIENCSR3: USB INDEXED ENDPOINT CONTROL STATUS REGISTER 3 (ENDPOINT 1-7)

| Bit Range | Bit 31/23/15/7 | Bit 30/22/14/6 | Bit 29/21/13/5 | Bit 28/20/12/4 | Bit 27/19/11/3 | Bit 26/18/10/2 | Bit 25/17/9/1 | Bit 24/16/8/0 |
|-----------|----------------|----------------|----------------|----------------|----------------|----------------|---------------|---------------|
| 31:24 | R-x | R-x | R-x | R-x | R-x | R-x | R-x | R-x |
| | RXFIFOSZ<3:0> | | | | TXFIFOSZ<3:0> | | | |
| 23:16 | U-0 | U-0 | U-0 | U-0 | U-0 | U-0 | U-0 | U-0 |
| | — | — | — | — | — | — | — | — |
| 15:8 | R/W-0 | R/W-0 | R/W-0 | R/W-0 | R/W-0 | R/W-0 | R/W-0 | R/W-0 |
| | RXINTERV<7:0> | | | | | | | |
| 7:0 | R/W-0 | R/W-0 | R/W-0 | R/W-0 | R/W-0 | R/W-0 | R/W-0 | R/W-0 |
| | SPEED<1:0> | | PROTOCOL<1:0> | | TEP<3:0> | | | |

Legend:

R = Readable bit W = Writable bit U = Unimplemented bit, read as '0'
 -n = Value at POR '1' = Bit is set '0' = Bit is cleared x = Bit is unknown

bit 31-28 **RXFIFOSZ<3:0>**: Receive FIFO Size bits

1111 = Reserved
 1110 = Reserved
 1101 = 8192 bytes
 1100 = 4096 bytes

•
 •
 •

0011 = 8 bytes
 0010 = Reserved
 0001 = Reserved
 0000 = Reserved or endpoint has not been configured

This register only has this interpretation when dynamic sizing is not selected. It is not valid where dynamic FIFO sizing is used.

bit 27-24 **TXFIFOSZ<3:0>**: Transmit FIFO Size bits

1111 = Reserved
 1110 = Reserved
 1101 = 8192 bytes
 1100 = 4096 bytes

•
 •
 •

0011 = 8 bytes
 0010 = Reserved
 0001 = Reserved
 0000 = Reserved or endpoint has not been configured

This register only has this interpretation when dynamic sizing is not selected. It is not valid where dynamic FIFO sizing is used.

bit 23-16 **Unimplemented**: Read as '0'

PIC32MZ Embedded Connectivity with Floating Point Unit (EF) Family

REGISTER 11-11: USBIENCSR3: USB INDEXED ENDPOINT CONTROL STATUS REGISTER 3 (ENDPOINT 1-7) (CONTINUED)

bit 15-8 **RXINTERV<7:0>**: Endpoint RX Polling Interval/NAK Limit bits

For Interrupt and Isochronous transfers, this field defines the polling interval for the endpoint. For Bulk endpoints, this field sets the number of frames/microframes after which the endpoint should time out on receiving a stream of NAK responses.

The following table describes the valid values and meaning for this field:

| Transfer Type | Speed | Valid Values (m) | Interpretation |
|---------------|--------------|------------------|--|
| Interrupt | Low/Full | 0x01 to 0xFF | Polling interval is 'm' frames. |
| | High | 0x01 to 0x10 | Polling interval is $2^{(m-1)}$ frames. |
| Isochronous | Full or High | 0x01 to 0x10 | Polling interval is $2^{(m-1)}$ frames/microframes. |
| Bulk | Full or High | 0x02 to 0x10 | NAK limit is $2^{(m-1)}$ frames/microframes. A value of '0' or '1' disables the NAK time-out function. |

bit 7-6 **SPEED<1:0>**: RX Endpoint Operating Speed Control bits

11 = Low-Speed
10 = Full-Speed
01 = Hi-Speed
00 = Reserved

bit 5-4 **PROTOCOL<1:0>**: RX Endpoint Protocol Control bits

11 = Interrupt
10 = Bulk
01 = Isochronous
00 = Control

bit 3-0 **TEP<3:0>**: RX Target Endpoint Number bits

This value is the endpoint number contained in the TX endpoint descriptor returned to the USB module during device enumeration.

PIC32MZ Embedded Connectivity with Floating Point Unit (EF) Family

REGISTER 11-12: USBFIFOx: USB FIFO DATA REGISTER 'x' ('x' = 0-7)

| Bit Range | Bit 31/23/15/7 | Bit 30/22/14/6 | Bit 29/21/13/5 | Bit 28/20/12/4 | Bit 27/19/11/3 | Bit 26/18/10/2 | Bit 25/17/9/1 | Bit 24/16/8/0 |
|-------------|----------------|----------------|----------------|----------------|----------------|----------------|---------------|---------------|
| 31:24 | R/W-0 | R/W-0 | R/W-0 | R/W-0 | R/W-0 | R/W-0 | R/W-0 | R/W-0 |
| DATA<31:24> | | | | | | | | |
| 23:16 | R/W-0 | R/W-0 | R/W-0 | R/W-0 | R/W-0 | R/W-0 | R/W-0 | R/W-0 |
| DATA<23:16> | | | | | | | | |
| 15:8 | R/W-0 | R/W-0 | R/W-0 | R/W-0 | R/W-0 | R/W-0 | R/W-0 | R/W-0 |
| DATA<15:8> | | | | | | | | |
| 7:0 | R/W-0 | R/W-0 | R/W-0 | R/W-0 | R/W-0 | R/W-0 | R/W-0 | R/W-0 |
| DATA<7:0> | | | | | | | | |

Legend:

| | | |
|-------------------|------------------|--|
| R = Readable bit | W = Writable bit | U = Unimplemented bit, read as '0' |
| -n = Value at POR | '1' = Bit is set | '0' = Bit is cleared x = Bit is unknown |

bit 31-0 **DATA<31:0>**: USB Transmit/Receive FIFO Data bits

Writes to this register loads data into the Tx FIFO for the corresponding endpoint. Reading from this register unloads data from the Rx FIFO for the corresponding endpoint.

Transfers may be 8-bit, 16-bit or 32-bit as required, and any combination of access is allowed provided the data accessed is contiguous. However, all transfers associated with one packet must be of the same width so that data is consistently byte-, word- or double-word aligned. The last transfer may contain fewer bytes than the previous transfers in order to complete an odd-byte or odd-word transfer.

PIC32MZ Embedded Connectivity with Floating Point Unit (EF) Family

REGISTER 11-13: USBOTG: USB OTG CONTROL/STATUS REGISTER

| Bit Range | Bit 31/23/15/7 | Bit 30/22/14/6 | Bit 29/21/13/5 | Bit 28/20/12/4 | Bit 27/19/11/3 | Bit 26/18/10/2 | Bit 25/17/9/1 | Bit 24/16/8/0 |
|-----------|----------------|----------------|----------------|----------------|----------------|----------------|---------------|---------------|
| 31:24 | U-0 | U-0 | U-0 | R/W-0 | R/W-0 | R/W-0 | R/W-0 | R/W-0 |
| | — | — | — | RXDPB | RXFIFOSZ<3:0> | | | |
| 23:16 | U-0 | U-0 | U-0 | R/W-0 | R/W-0 | R/W-0 | R/W-0 | R/W-0 |
| | — | — | — | TXDPB | TXFIFOSZ<3:0> | | | |
| 15:8 | U-0 | U-0 | U-0 | U-0 | U-0 | U-0 | R/W-0 | R/W-0 |
| | — | — | — | — | — | — | TXEDMA | RXEDMA |
| 7:0 | R-1 | R-0 | R-0 | R-0 | R-0 | R-0 | R/W-0, HC | R/W-0 |
| | BDEV | FSDEV | LSDEV | VBUS<1:0> | | HOSTMODE | HOSTREQ | SESSION |

Legend:

R = Readable bit
-n = Value at POR

W = Writable bit
'1' = Bit is set

U = Unimplemented bit, read as '0'
'0' = Bit is cleared
x = Bit is unknown

bit 31-29 **Unimplemented:** Read as '0'

bit 28 **RXDPB:** RX Endpoint Double-packet Buffering Control bit
1 = Double-packet buffer is supported. This doubles the size set in RXFIFOSZ.
0 = Double-packet buffer is not supported

bit 27-24 **RXFIFOSZ<3:0>:** RX Endpoint FIFO Packet Size bits

The maximum packet size to allowed for (before any splitting within the FIFO of Bulk/High-Bandwidth packets prior to transmission)

1111 = Reserved

-
-
-

1010 = Reserved
1001 = 4096 bytes
1000 = 2048 bytes
0111 = 1024 bytes
0110 = 512 bytes
0101 = 256 bytes
0100 = 128 bytes
0011 = 64 bytes
0010 = 32 bytes
0001 = 16 bytes
0000 = 8 bytes

bit 23-21 **Unimplemented:** Read as '0'

bit 20 **TXDPB:** TX Endpoint Double-packet Buffering Control bit
1 = Double-packet buffer is supported. This doubles the size set in TXFIFOSZ.
0 = Double-packet buffer is not supported

PIC32MZ Embedded Connectivity with Floating Point Unit (EF) Family

REGISTER 11-13: USBOTG: USB OTG CONTROL/STATUS REGISTER (CONTINUED)

bit 19-16 **TXFIFOSZ<3:0>**: TX Endpoint FIFO packet size bits

The maximum packet size to allowed for (before any splitting within the FIFO of Bulk/High-Bandwidth packets prior to transmission)

1111 = Reserved

•
•
•

1010 = Reserved

1001 = 4096 bytes

1000 = 2048 bytes

0111 = 1024 bytes

0110 = 512 bytes

0101 = 256 bytes

0100 = 128 bytes

0011 = 64 bytes

0010 = 32 bytes

0001 = 16 bytes

0000 = 8 bytes

bit 15-10 **Unimplemented**: Read as '0'

bit 9 **TXEDMA**: TX Endpoint DMA Assertion Control bit

1 = DMA_REQ signal for all IN endpoints will be deasserted when MAXP-8 bytes have been written to an endpoint. This is Early mode.

0 = DMA_REQ signal for all IN endpoints will be deasserted when MAXP bytes have been written to an endpoint. This is Late mode.

bit 8 **RXEDMA**: RX Endpoint DMA Assertion Control bit

1 = DMA_REQ signal for all OUT endpoints will be deasserted when MAXP-8 bytes have been written to an endpoint. This is Early mode.

0 = DMA_REQ signal for all OUT endpoints will be deasserted when MAXP bytes have been written to an endpoint. This is Late mode.

bit 7 **BDEV**: USB Device Type bit

1 = USB is operating as a 'B' device

0 = USB is operating as an 'A' device

bit 6 **FSDEV**: Full-Speed/Hi-Speed device detection bit (*Host mode*)

1 = A Full-Speed or Hi-Speed device has been detected being connected to the port

0 = No Full-Speed or Hi-Speed device detected

bit 5 **LSDEV**: Low-Speed Device Detection bit (*Host mode*)

1 = A Low-Speed device has been detected being connected to the port

0 = No Low-Speed device detected

bit 4-3 **VBUS<1:0>**: VBUS Level Detection bits

11 = Above VBUS Valid

10 = Above AValid, below VBUS Valid

01 = Above Session End, below AValid

00 = Below Session End

bit 2 **HOSTMODE**: Host Mode bit

1 = USB module is acting as a Host

0 = USB module is not acting as a Host

bit 1 **HOSTREQ**: Host Request Control bit

'B' device only:

1 = USB module initiates the Host Negotiation when Suspend mode is entered. This bit is cleared when Host Negotiation is completed.

0 = Host Negotiation is not taking place

PIC32MZ Embedded Connectivity with Floating Point Unit (EF) Family

REGISTER 11-13: USBOTG: USB OTG CONTROL/STATUS REGISTER (CONTINUED)

bit 0 **SESSION:** Active Session Control/Status bit

'A' device:

1 = Start a session

0 = End a session

'B' device:

1 = (Read) Session has started or is in progress, (Write) Initiate the Session Request Protocol

0 = When USB module is in Suspend mode, clearing this bit will cause a software disconnect

Clearing this bit when the USB module is not suspended will result in undefined behavior.

PIC32MZ Embedded Connectivity with Floating Point Unit (EF) Family

REGISTER 11-14: USBFIFOA: USB FIFO ADDRESS REGISTER

| Bit Range | Bit 31/23/15/7 | Bit 30/22/14/6 | Bit 29/21/13/5 | Bit 28/20/12/4 | Bit 27/19/11/3 | Bit 26/18/10/2 | Bit 25/17/9/1 | Bit 24/16/8/0 |
|-----------|----------------|----------------|----------------|----------------|----------------|----------------|---------------|---------------|
| 31:24 | U-0 | U-0 | U-0 | R/W-0 | R/W-0 | R/W-0 | R/W-0 | R/W-0 |
| | — | — | — | RXFIFOAD<12:8> | | | | |
| 23:16 | R/W-0 | R/W-0 | R/W-0 | R/W-0 | R/W-0 | R/W-0 | R/W-0 | R/W-0 |
| | RXFIFOAD<7:0> | | | | | | | |
| 15:8 | U-0 | U-0 | U-0 | R/W-0 | R/W-0 | R/W-0 | R/W-0 | R/W-0 |
| | — | — | — | TXFIFOAD<12:8> | | | | |
| 7:0 | R/W-0 | R/W-0 | R/W-0 | R/W-0 | R/W-0 | R/W-0 | R/W-0 | R/W-0 |
| | TXFIFOAD<7:0> | | | | | | | |

Legend:

R = Readable bit W = Writable bit U = Unimplemented bit, read as '0'
 -n = Value at POR '1' = Bit is set '0' = Bit is cleared x = Bit is unknown

bit 31-29 **Unimplemented:** Read as '0'

bit 28-16 **RXFIFOAD<12:0>:** Receive Endpoint FIFO Address bits

Start address of the endpoint FIFO in units of 8 bytes as follows:

11111111111111 = 0xFFFF8

•
•
•

00000000000010 = 0x0010

00000000000001 = 0x0008

00000000000000 = 0x0000

bit 15-13 **Unimplemented:** Read as '0'

bit 12-0 **TXFIFOAD<12:0>:** Transmit Endpoint FIFO Address bits

Start address of the endpoint FIFO in units of 8 bytes as follows:

11111111111111 = 0xFFFF8

•
•
•

00000000000010 = 0x0010

00000000000001 = 0x0008

00000000000000 = 0x0000

PIC32MZ Embedded Connectivity with Floating Point Unit (EF) Family

REGISTER 11-15: USBHWVER: USB HARDWARE VERSION REGISTER

| Bit Range | Bit 31/23/15/7 | Bit 30/22/14/6 | Bit 29/21/13/5 | Bit 28/20/12/4 | Bit 27/19/11/3 | Bit 26/18/10/2 | Bit 25/17/9/1 | Bit 24/16/8/0 |
|-----------|----------------|----------------|----------------|----------------|----------------|----------------|---------------|---------------|
| 31:24 | U-0 | U-0 | U-0 | U-0 | U-0 | U-0 | U-0 | U-0 |
| | — | — | — | — | — | — | — | — |
| 23:16 | U-0 | U-0 | U-0 | U-0 | U-0 | U-0 | U-0 | U-0 |
| | — | — | — | — | — | — | — | — |
| 15:8 | R-0 | R-0 | R-0 | R-0 | R-1 | R-0 | R-0 | R-0 |
| | RC | VERMAJOR<4:0> | | | | | VERMINOR<9:8> | |
| 7:0 | R-0 | R-0 | R-0 | R-0 | R-0 | R-0 | R-0 | R-0 |
| | VERMINOR<7:0> | | | | | | | |

Legend:

| | | |
|-------------------|------------------|--|
| R = Readable bit | W = Writable bit | U = Unimplemented bit, read as '0' |
| -n = Value at POR | '1' = Bit is set | '0' = Bit is cleared x = Bit is unknown |

bit 31-16 **Unimplemented:** Read as '0'

bit 15 **RC:** Release Candidate bit

1 = USB module was created using a release candidate

0 = USB module was created using a full release

bit 14-10 **VERMAJOR<4:0>:** USB Module Major Version number bits

This read-only number is the Major version number for the USB module.

bit 9-0 **VERMINOR<9:0>:** USB Module Minor Version number bits

This read-only number is the Minor version number for the USB module.

PIC32MZ Embedded Connectivity with Floating Point Unit (EF) Family

REGISTER 11-16: USBINFO: USB INFORMATION REGISTER

| Bit Range | Bit 31/23/15/7 | Bit 30/22/14/6 | Bit 29/21/13/5 | Bit 28/20/12/4 | Bit 27/19/11/3 | Bit 26/18/10/2 | Bit 25/17/9/1 | Bit 24/16/8/0 |
|---------------|----------------|----------------|----------------|----------------|----------------|----------------|---------------|---------------|
| 31:24 | R/W-0 | R/W-0 | R/W-1 | R/W-1 | R/W-1 | R/W-1 | R/W-0 | R/W-0 |
| VPLEN<7:0> | | | | | | | | |
| 23:16 | R/W-0 | R/W-1 | R/W-0 | R/W-1 | R/W-1 | R/W-1 | R/W-0 | R/W-0 |
| WTCON<3:0> | | | | WTID<3:0> | | | | |
| 15:8 | R-1 | R-0 | R-0 | R-0 | R-1 | R-1 | R-0 | R-0 |
| DMACHANS<3:0> | | | | RAMBITS<3:0> | | | | |
| 7:0 | R-0 | R-1 | R-1 | R-1 | R-0 | R-1 | R-1 | R-1 |
| RXENDPTS<3:0> | | | | TXENDPTS<3:0> | | | | |

Legend:

| | | |
|-------------------|------------------|--|
| R = Readable bit | W = Writable bit | U = Unimplemented bit, read as '0' |
| -n = Value at POR | '1' = Bit is set | '0' = Bit is cleared x = Bit is unknown |

bit 31-24 **VPLEN<7:0>**: VBUS pulsing charge length bits

Sets the duration of the VBUS pulsing charge in units of 546.1 μ s. (The default setting corresponds to 32.77 ms.)

bit 23-20 **WTCON<3:0>**: Connect/Disconnect filter control bits

Sets the wait to be applied to allow for the connect/disconnect filter in units of 533.3 ns. The default setting corresponds to 2.667 μ s.

bit 19-6 **WTID<3:0>**: ID delay valid control bits

Sets the delay to be applied from IDPULLUP being asserted to IDDIG being considered valid in units of 4.369ms. The default setting corresponds to 52.43ms.

bit 15-12 **DMACHANS<3:0>**: DMA Channels bits

These read-only bits provide the number of DMA channels in the USB module. For the PIC32MZ EF family, this number is 8.

bit 11-8 **RAMBITS<3:0>**: RAM address bus width bits

These read-only bits provide the width of the RAM address bus. For the PIC32MZ EF family, this number is 12.

bit 7-4 **RXENDPTS<3:0>**: Included RX Endpoints bits

This read-only register gives the number of RX endpoints in the design. For the PIC32MZ EF family, this number is 7.

bit 3-0 **TXENDPTS<3:0>**: Included TX Endpoints bits

These read-only bits provide the number of TX endpoints in the design. For the PIC32MZ EF family, this number is 7.

PIC32MZ Embedded Connectivity with Floating Point Unit (EF) Family

REGISTER 11-17: USBE0FRST: USB END-OF-FRAME/SOFT RESET CONTROL REGISTER

| Bit Range | Bit 31/23/15/7 | Bit 30/22/14/6 | Bit 29/21/13/5 | Bit 28/20/12/4 | Bit 27/19/11/3 | Bit 26/18/10/2 | Bit 25/17/9/1 | Bit 24/16/8/0 |
|-----------|----------------|----------------|----------------|----------------|----------------|----------------|---------------|---------------|
| 31:24 | U-0 | U-0 | U-0 | U-0 | U-0 | U-0 | R/W-0 | R/W-0 |
| | — | — | — | — | — | — | NRSTX | NRST |
| 23:16 | R/W-0 | R/W-1 | R/W-1 | R/W-1 | R/W-0 | R.W-0 | R/W-1 | R/W-0 |
| | LSEOF<7:0> | | | | | | | |
| 15:8 | R/W-0 | R/W-1 | R/W-1 | R/W-1 | R/W-0 | R.W-1 | R/W-1 | R/W-1 |
| | FSEOF<7:0> | | | | | | | |
| 7:0 | R/W-1 | R/W-0 | R/W-0 | R/W-0 | R/W-0 | R.W-0 | R/W-0 | R/W-0 |
| | HSEOF<7:0> | | | | | | | |

Legend:

| | | |
|-------------------|------------------|--|
| R = Readable bit | W = Writable bit | U = Unimplemented bit, read as '0' |
| -n = Value at POR | '1' = Bit is set | '0' = Bit is cleared x = Bit is unknown |

- bit 31-26 **Unimplemented:** Read as '0'
- bit 25 **NRSTX:** Reset of XCLK Domain bit
1 = Reset the XCLK domain, which is clock recovered from the received data by the PHY
0 = Normal operation
- bit 24 **NRST:** Reset of CLK Domain bit
1 = Reset the CLK domain, which is clock recovered from the peripheral bus
0 = Normal operation
- bit 23-16 **LSEOF<7:0>:** Low-Speed EOF bits
These bits set the Low-Speed transaction in units of 1.067 μ s (default setting is 121.6 μ s) prior to the EOF to stop new transactions from beginning.
- bit 15-8 **FSEOF<7:0>:** Full-Speed EOF bits
These bits set the Full-Speed transaction in units of 533.3 μ s (default setting is 63.46 μ s) prior to the EOF to stop new transactions from beginning.
- bit 7-0 **HSEOF<7:0>:** Hi-Speed EOF bits
These bits set the Hi-Speed transaction in units of 133.3 μ s (default setting is 17.07 μ s) prior to the EOF to stop new transactions from beginning.

PIC32MZ Embedded Connectivity with Floating Point Unit (EF) Family

REGISTER 11-18: USB_xTXA: USB ENDPOINT 'x' TRANSMIT ADDRESS REGISTER

| Bit Range | Bit 31/23/15/7 | Bit 30/22/14/6 | Bit 29/21/13/5 | Bit 28/20/12/4 | Bit 27/19/11/3 | Bit 26/18/10/2 | Bit 25/17/9/1 | Bit 24/16/8/0 |
|-----------|----------------|----------------|----------------|----------------|----------------|----------------|---------------|---------------|
| 31:24 | U-0 | R/W-0 | R/W-0 | R/W-0 | R/W-0 | R/W-0 | R/W-0 | R/W-0 |
| | — | TXHUBPRT<6:0> | | | | | | |
| 23:16 | R/W-0 | R/W-0 | R/W-0 | R/W-0 | R/W-0 | R/W-0 | R/W-0 | R/W-0 |
| | MULTTRAN | TXHUBADD<6:0> | | | | | | |
| 15:8 | U-0 | U-0 | U-0 | U-0 | U-0 | U-0 | U-0 | U-0 |
| | — | — | — | — | — | — | — | — |
| 7:0 | U-0 | R/W-0 | R/W-0 | R/W-0 | R/W-0 | R/W-0 | R/W-0 | R/W-0 |
| | — | TXFADDR<6:0> | | | | | | |

Legend:

| | | |
|-------------------|------------------|--|
| R = Readable bit | W = Writable bit | U = Unimplemented bit, read as '0' |
| -n = Value at POR | '1' = Bit is set | '0' = Bit is cleared x = Bit is unknown |

bit 31 **Unimplemented:** Read as '0'

bit 30-24 **TXHUBPRT<6:0>:** TX Hub Port bits (*Host mode*)

When a low- or Full-Speed device is connected to this endpoint via a Hi-Speed USB 2.0 hub, this field records the port number of that USB 2.0 hub.

bit 23 **MULTTRAN:** TX Hub Multiple Translators bit (*Host mode*)

1 = The USB 2.0 hub has multiple transaction translators
0 = The USB 2.0 hub has a single transaction translator

bit 22-16 **TXHUBADD<6:0>:** TX Hub Address bits (*Host mode*)

When a Low-Speed or Full-Speed device is connected to this endpoint via a Hi-Speed USB 2.0 hub, these bits record the address of the USB 2.0 hub.

bit 15-7 **Unimplemented:** Read as '0'

bit 6-0 **TXFADDR<6:0>:** TX Functional Address bits (*Host mode*)

Specifies the address for the target function that is to be accessed through the associated endpoint. It needs to be defined for each TX endpoint that is used.

PIC32MZ Embedded Connectivity with Floating Point Unit (EF) Family

REGISTER 11-19: USB_xRXA: USB ENDPOINT 'x' RECEIVE ADDRESS REGISTER

| Bit Range | Bit 31/23/15/7 | Bit 30/22/14/6 | Bit 29/21/13/5 | Bit 28/20/12/4 | Bit 27/19/11/3 | Bit 26/18/10/2 | Bit 25/17/9/1 | Bit 24/16/8/0 |
|---------------|-------------------|----------------|----------------|----------------|----------------|----------------|---------------|---------------|
| 31:24 | U-0 — | R/W-0 | R/W-0 | R/W-0 | R/W-0 | R/W-0 | R/W-0 | R/W-0 |
| RXHUBPRT<6:0> | | | | | | | | |
| 23:16 | R/W-0 MULTTRAN | R/W-0 | R/W-0 | R/W-0 | R/W-0 | R/W-0 | R/W-0 | R/W-0 |
| RXHUBADD<6:0> | | | | | | | | |
| 15:8 | U-0 — | U-0 — | U-0 — | U-0 — | U-0 — | U-0 — | U-0 — | U-0 — |
| 7:0 | U-0 — | R/W-0 | R/W-0 | R/W-0 | R/W-0 | R/W-0 | R/W-0 | R/W-0 |
| RXFADDR<6:0> | | | | | | | | |

| | | |
|-------------------|-----------------------|--|
| Legend: | HC = Hardware Cleared | HS = Hardware Set |
| R = Readable bit | W = Writable bit | U = Unimplemented bit, read as '0' |
| -n = Value at POR | '1' = Bit is set | '0' = Bit is cleared x = Bit is unknown |

bit 31 **Unimplemented:** Read as '0'

bit 30-24 **RXHUBPRT<6:0>:** RX Hub Port bits (*Host mode*)

When a low- or Full-Speed device is connected to this endpoint via a Hi-Speed USB 2.0 hub, this field records the port number of that USB 2.0 hub.

bit 23 **MULTTRAN:** RX Hub Multiple Translators bit (*Host mode*)

1 = The USB 2.0 hub has multiple transaction translators
0 = The USB 2.0 hub has a single transaction translator

bit 22-16 **RXHUBADD<6:0>:** RX Hub Address bits (*Host mode*)

When a Low-Speed or Full-Speed device is connected to this endpoint via a Hi-Speed USB 2.0 hub, these bits record the address of the USB 2.0 hub.

bit 15-7 **Unimplemented:** Read as '0'

bit 6-0 **RXFADDR<6:0>:** RX Functional Address bits (*Host mode*)

Specifies the address for the target function that is to be accessed through the associated endpoint. It needs to be defined for each RX endpoint that is used.

PIC32MZ Embedded Connectivity with Floating Point Unit (EF) Family

REGISTER 11-20: USBDMAINT: USB DMA INTERRUPT REGISTER

| Bit Range | Bit 31/23/15/7 | Bit 30/22/14/6 | Bit 29/21/13/5 | Bit 28/20/12/4 | Bit 27/19/11/3 | Bit 26/18/10/2 | Bit 25/17/9/1 | Bit 24/16/8/0 |
|-----------|----------------|----------------|----------------|----------------|----------------|----------------|---------------|---------------|
| 31:24 | U-0 | U-0 | U-0 | U-0 | U-0 | U-0 | U-0 | U-0 |
| | — | — | — | — | — | — | — | — |
| 23:16 | U-0 | U-0 | U-0 | U-0 | U-0 | U-0 | U-0 | U-0 |
| | — | — | — | — | — | — | — | — |
| 15:8 | U-0 | U-0 | U-0 | U-0 | U-0 | U-0 | U-0 | U-0 |
| | — | — | — | — | — | — | — | — |
| 7:0 | R/W-0, HS | R/W-0, HS | R/W-0, HS | R/W-0, HS | R/W-0, HS | R/W-0, HS | R/W-0, HS | R/W-0, HS |
| | DMA8IF | DMA7IF | DMA6IF | DMA5IF | DMA4IF | DMA3IF | DMA2IF | DMA1IF |

Legend:

R = Readable bit
-n = Value at POR

W = Writable bit
'1' = Bit is set

U = Unimplemented bit, read as '0'
'0' = Bit is cleared
x = Bit is unknown

bit 31-8 **Unimplemented:** Read as '0'

bit 7-0 **DMAxIF:** DMA Channel 'x' Interrupt bit

1 = The DMA channel has an interrupt event

0 = No interrupt event

All bits are cleared on a read of the register.

PIC32MZ Embedded Connectivity with Floating Point Unit (EF) Family

REGISTER 11-21: USBDMAxC: USB DMA CHANNEL 'x' CONTROL REGISTER ('x' = 1-8)

| Bit Range | Bit 31/23/15/7 | Bit 30/22/14/6 | Bit 29/21/13/5 | Bit 28/20/12/4 | Bit 27/19/11/3 | Bit 26/18/10/2 | Bit 25/17/9/1 | Bit 24/16/8/0 |
|-----------|----------------|----------------|----------------|----------------|----------------|------------------------|---------------|-----------------|
| 31:24 | U-0 — | U-0 — | U-0 — | U-0 — | U-0 — | U-0 — | U-0 — | U-0 — |
| 23:16 | U-0 — | U-0 — | U-0 — | U-0 — | U-0 — | U-0 — | U-0 — | U-0 — |
| 15:8 | U-0 — | U-0 — | U-0 — | U-0 — | U-0 — | R/W-0 DMABRSTM<1:0> | R/W-0 | R/W-0 DMAERR |
| 7:0 | R/W-0 | R/W-0 | R/W-0 | R/W-0 | R/W-0 | R/W-0 | R/W-0 | R/W-0 |
| | DMAEP<3:0> | | | | DMAIE | DMAMODE | DMADIR | DMAEN |

Legend:

R = Readable bit
-n = Value at POR

W = Writable bit
'1' = Bit is set

U = Unimplemented bit, read as '0'
'0' = Bit is cleared
x = Bit is unknown

bit 31-11 **Unimplemented:** Read as '0'

bit 10-9 **DMABRSTM<1:0>:** DMA Burst Mode Selection bit

- 11 = Burst Mode 3: INCR16, INCR8, INCR4 or unspecified length
- 10 = Burst Mode 2: INCR8, INCR4 or unspecified length
- 01 = Burst Mode 1: INCR4 or unspecified length
- 00 = Burst Mode 0: Bursts of unspecified length

bit 8 **DMAERR:** Bus Error bit

- 1 = A bus error has been observed on the input
- 0 = The software writes this to clear the error

bit 7-4 **DMAEP<3:0>:** DMA Endpoint Assignment bits

These bits hold the endpoint that the DMA channel is assigned to. Valid values are 0-7.

bit 3 **DMAIE:** DMA Interrupt Enable bit

- 1 = Interrupt is enabled for this channel
- 0 = Interrupt is disabled for this channel

bit 2 **DMAMODE:** DMA Transfer Mode bit

- 1 = DMA Mode1 Transfers
- 0 = DMA Mode0 Transfers

bit 1 **DMADIR:** DMA Transfer Direction bit

- 1 = DMA Read (TX endpoint)
- 0 = DMA Write (RX endpoint)

bit 0 **DMAEN:** DMA Enable bit

- 1 = Enable the DMA transfer and start the transfer
- 0 = Disable the DMA transfer

PIC32MZ Embedded Connectivity with Floating Point Unit (EF) Family

REGISTER 11-22: USBDMA_xA: USB DMA CHANNEL 'x' MEMORY ADDRESS REGISTER ('x' = 1-8)

| Bit Range | Bit 31/23/15/7 | Bit 30/22/14/6 | Bit 29/21/13/5 | Bit 28/20/12/4 | Bit 27/19/11/3 | Bit 26/18/10/2 | Bit 25/17/9/1 | Bit 24/16/8/0 |
|-----------|----------------|----------------|----------------|----------------|----------------|----------------|---------------|---------------|
| 31:24 | R/W-0 | R/W-0 | R/W-0 | R/W-0 | R/W-0 | R/W-0 | R/W-0 | R/W-0 |
| | DMAADDR<31:24> | | | | | | | |
| 23:16 | R/W-0 | R/W-0 | R/W-0 | R/W-0 | R/W-0 | R/W-0 | R/W-0 | R/W-0 |
| | DMAADDR<23:16> | | | | | | | |
| 15:8 | R/W-0 | R/W-0 | R/W-0 | R/W-0 | R/W-0 | R/W-0 | R/W-0 | R/W-0 |
| | DMAADDR<15:8> | | | | | | | |
| 7:0 | R/W-0 | R/W-0 | R/W-0 | R/W-0 | R/W-0 | R/W-0 | R-0 | R-0 |
| | DMAADDR<7:0> | | | | | | | |

Legend:

R = Readable bit W = Writable bit U = Unimplemented bit, read as '0'
 -n = Value at POR '1' = Bit is set '0' = Bit is cleared x = Bit is unknown

bit 31-0 **DMAADDR<31:0>**: DMA Memory Address bits

This register identifies the current memory address of the corresponding DMA channel. The initial memory address written to this register during initialization must have a value such that its modulo 4 value is equal to '0'. The lower two bits of this register are read only and cannot be set by software. As the DMA transfer progresses, the memory address will increment as bytes are transferred.

REGISTER 11-23: USBDMA_xN: USB DMA CHANNEL 'x' COUNT REGISTER ('X' = 1-8)

| Bit Range | Bit 31/23/15/7 | Bit 30/22/14/6 | Bit 29/21/13/5 | Bit 28/20/12/4 | Bit 27/19/11/3 | Bit 26/18/10/2 | Bit 25/17/9/1 | Bit 24/16/8/0 |
|-----------|-----------------|----------------|----------------|----------------|----------------|----------------|---------------|---------------|
| 31:24 | R/W-0 | R/W-0 | R/W-0 | R/W-0 | R/W-0 | R/W-0 | R/W-0 | R/W-0 |
| | DMACOUNT<31:24> | | | | | | | |
| 23:16 | R/W-0 | R/W-0 | R/W-0 | R/W-0 | R/W-0 | R/W-0 | R/W-0 | R/W-0 |
| | DMACOUNT<23:16> | | | | | | | |
| 15:8 | R/W-0 | R/W-0 | R/W-0 | R/W-0 | R/W-0 | R/W-0 | R/W-0 | R/W-0 |
| | DMACOUNT<15:8> | | | | | | | |
| 7:0 | R/W-0 | R/W-0 | R/W-0 | R/W-0 | R/W-0 | R/W-0 | R/W-0 | R/W-0 |
| | DMACOUNT<7:0> | | | | | | | |

Legend:

R = Readable bit W = Writable bit U = Unimplemented bit, read as '0'
 -n = Value at POR '1' = Bit is set '0' = Bit is cleared x = Bit is unknown

bit 31-0 **DMACOUNT<31:0>**: DMA Transfer Count bits

This register identifies the current DMA count of the transfer. Software will set the initial count of the transfer which identifies the entire transfer length. As the count progresses this count is decremented as bytes are transferred.

PIC32MZ Embedded Connectivity with Floating Point Unit (EF) Family

REGISTER 11-24: USBExRPC: USB ENDPOINT 'x' REQUEST PACKET COUNT REGISTER (HOST MODE ONLY) ('x' = 1-7)

| Bit Range | Bit 31/23/15/7 | Bit 30/22/14/6 | Bit 29/21/13/5 | Bit 28/20/12/4 | Bit 27/19/11/3 | Bit 26/18/10/2 | Bit 25/17/9/1 | Bit 24/16/8/0 |
|-----------|----------------|----------------|----------------|----------------|----------------|----------------|---------------|---------------|
| 31:24 | U-0 | U-0 | U-0 | U-0 | U-0 | U-0 | U-0 | U-0 |
| | — | — | — | — | — | — | — | — |
| 23:16 | U-0 | U-0 | U-0 | U-0 | U-0 | U-0 | U-0 | U-0 |
| | — | — | — | — | — | — | — | — |
| 15:8 | R/W-0 | R/W-0 | R/W-0 | R/W-0 | R/W-0 | R/W-0 | R/W-0 | R/W-0 |
| | RQPKTCNT<15:8> | | | | | | | |
| 7:0 | R/W-0 | R/W-0 | R/W-0 | R/W-0 | R/W-0 | R/W-0 | R/W-0 | R/W-0 |
| | RQPKTCNT<7:0> | | | | | | | |

Legend:

R = Readable bit
-n = Value at POR

W = Writable bit
'1' = Bit is set

U = Unimplemented bit, read as '0'
'0' = Bit is cleared
x = Bit is unknown

bit 31-16 **Unimplemented:** Read as '0'

bit 15-0 **RQPKTCNT<15:0>:** Request Packet Count bits

Sets the number of packets of size MAXP that are to be transferred in a block transfer. This register is only available in *Host mode* when AUTOREQ is set.

REGISTER 11-25: USBDPBFD: USB DOUBLE PACKET BUFFER DISABLE REGISTER

| Bit Range | Bit 31/23/15/7 | Bit 30/22/14/6 | Bit 29/21/13/5 | Bit 28/20/12/4 | Bit 27/19/11/3 | Bit 26/18/10/2 | Bit 25/17/9/1 | Bit 24/16/8/0 |
|-----------|----------------|----------------|----------------|----------------|----------------|----------------|---------------|---------------|
| 31:24 | U-0 | U-0 | U-0 | U-0 | U-0 | U-0 | U-0 | U-0 |
| | — | — | — | — | — | — | — | — |
| 23:16 | R/W-0 | R/W-0 | R/W-0 | R/W-0 | R/W-0 | R/W-0 | R/W-0 | U-0 |
| | EP7TXD | EP6TXD | EP5TXD | EP4TXD | EP3TXD | EP2TXD | EP1TXD | — |
| 15:8 | U-0 | U-0 | U-0 | U-0 | U-0 | U-0 | U-0 | U-0 |
| | — | — | — | — | — | — | — | — |
| 7:0 | R/W-0 | R/W-0 | R/W-0 | R/W-0 | R/W-0 | R/W-0 | R/W-0 | U-0 |
| | EP7RXD | EP6RXD | EP5RXD | EP4RXD | EP3RXD | EP2RXD | EP1RXD | — |

Legend:

R = Readable bit
-n = Value at POR

W = Writable bit
'1' = Bit is set

U = Unimplemented bit, read as '0'
'0' = Bit is cleared
x = Bit is unknown

bit 31-17 **EP7TXD:EP1TXD:** TX Endpoint 'x' Double Packet Buffer Disable bits

1 = TX double packet buffering is disabled for endpoint 'x'
0 = TX double packet buffering is enabled for endpoint 'x'

bit 16 **Unimplemented:** Read as '0'

bit 15-1 **EP7RXD:EP1RXD:** RX Endpoint 'x' Double Packet Buffer Disable bits

1 = RX double packet buffering is disabled for endpoint 'x'
0 = RX double packet buffering is enabled for endpoint 'x'

bit 0 **Unimplemented:** Read as '0'

PIC32MZ Embedded Connectivity with Floating Point Unit (EF) Family

REGISTER 11-28: USBLPMR1: USB LINK POWER MANAGEMENT CONTROL REGISTER 1

| Bit Range | Bit 31/23/15/7 | Bit 30/22/14/6 | Bit 29/21/13/5 | Bit 28/20/12/4 | Bit 27/19/11/3 | Bit 26/18/10/2 | Bit 25/17/9/1 | Bit 24/16/8/0 |
|-----------|----------------|----------------|-------------------|-------------------|---------------------|------------------|---------------------|---------------------|
| 31:24 | U-0 — | U-0 — | R/W-0 LPMERRIE | R/W-0 LPMRESIE | R/W-0 LPMACKIE | R/W-0 LPMNYIE | R/W-0 LPMSTIE | R/W-0 LPMTOIE |
| 23:16 | U-0 — | U-0 — | U-0 — | R/W-0 LPMNAK | R/W-0 LPMEN<1:0> | R/W-0 LPMRES | R/W-0, HC LPMRES | R/W-0, HC LPMXMT |
| 15:8 | R-0 — | R-0 — | R-0 — | R-0 — | U-0 — | U-0 — | U-0 — | R-0 RMTWAK |
| 7:0 | R-0 — | R-0 — | R-0 — | R-0 — | R-0 — | R-0 — | R-0 — | R-0 — |
| | HIRD<3:0> | | | | LNKSTATE<3:0> | | | |

| | |
|-------------------|------------------------------------|
| Legend: | HC = Hardware Cleared |
| R = Readable bit | W = Writable bit |
| -n = Value at POR | '1' = Bit is set |
| | U = Unimplemented bit, read as '0' |
| | '0' = Bit is cleared |
| | x = Bit is unknown |

bit 31-30 **Unimplemented:** Read as '0'

bit 29 **LPMERRIE:** LPM Error Interrupt Enable bit
 1 = LPMERR interrupt is enabled
 0 = LPMERR interrupt is disabled

bit 28 **LPMRESIE:** LPM Resume Interrupt Enable bit
 1 = LPMRES interrupt is enabled
 0 = LPMRES interrupt is disabled

bit 27 **LPMACKIE:** LPM Acknowledge Interrupt Enable bit
 1 = Enable the LPMACK Interrupt
 0 = Disable the LPMACK Interrupt

bit 26 **LPMNYIE:** LPM NYET Interrupt Enable bit
 1 = Enable the LPMNYET Interrupt
 0 = Disable the LPMNYET Interrupt

bit 25 **LPMSTIE:** LPM STALL Interrupt Enable bit
 1 = Enable the LPMST Interrupt
 0 = Disable the LPMST Interrupt

bit 24 **LPMTOIE:** LPM Time-out Interrupt Enable bit
 1 = Enable the LPMTO Interrupt
 0 = Disable the LPMTO Interrupt

bit 23-21 **Unimplemented:** Read as '0'

bit 20 **LPMNAK:** LPM-only Transaction Setting bit
 1 = All endpoints will respond to all transactions other than a LPM transaction with a NAK
 0 = Normal transaction operation
 Setting this bit to '1' will only take effect after the USB module as been LPM suspended.

bit 19-18 **LPMEN<1:0>:** LPM Enable bits (*Device mode*)
 11 = LPM Extended transactions are supported
 10 = LPM and Extended transactions are not supported
 01 = LPM mode is not supported but Extended transactions are supported
 00 = LPM Extended transactions are supported

bit 17 **LPMRES:** LPM Resume bit
 1 = Initiate resume (remote wake-up). Resume signaling is asserted for 50 μ s.
 0 = No resume operation
 This bit is self-clearing.

PIC32MZ Embedded Connectivity with Floating Point Unit (EF) Family

REGISTER 11-28: USBLPMR1: USB LINK POWER MANAGEMENT CONTROL REGISTER 1 (CONTINUED)

- bit 16 **LPMXMT**: LPM Transition to the L1 State bit
When in *Device mode*:
1 = USB module will transition to the L1 state upon the receipt of the next LPM transaction. LPMEN must be set to `0b11`. Both LPMXMT and LPMEN must be set in the same cycle.
0 = Maintain current state
When LPMXMT and LPMEN are set, the USB module can respond in the following ways:
- If no data is pending (all TX FIFOs are empty), the USB module will respond with an ACK. The bit will self clear and a software interrupt will be generated.
 - If data is pending (data resides in at least one TX FIFO), the USB module will respond with a NYET. In this case, the bit will not self clear however a software interrupt will be generated.
- When in *Host mode*:
1 = USB module will transmit an LPM transaction. This bit is self clearing, and will be immediately cleared upon receipt of any Token or three time-outs have occurred.
0 = Maintain current state
- bit 15-12 **ENDPOINT<3:0>**: LPM Token Packet Endpoint bits
This is the endpoint in the token packet of the LPM transaction.
- bit 11-9 **Unimplemented**: Read as '0'
- bit 8 **RMTWAK**: Remote Wake-up Enable bit
This bit is applied on a temporary basis only and is only applied to the current suspend state.
1 = Remote wake-up is enabled
0 = Remote wake-up is disabled
- bit 7-4 **HIRD<3:0>**: Host Initiated Resume Duration bits
The minimum time the host will drive resume on the bus. The value in this register corresponds to an actual resume time of:
$$\text{Resume Time} = 50 \mu\text{s} + \text{HIRD} * 75 \mu\text{s}$$

The resulting range is 50 μs to 1200 μs .
- bit 3-0 **LNKSTATE<3:0>**: Link State bits
This value is provided by the host to the peripheral to indicate what state the peripheral must transition to after the receipt and acceptance of a LPM transaction. The only valid value for this register is '1' for Sleep State (L1). All other values are reserved.

PIC32MZ Embedded Connectivity with Floating Point Unit (EF) Family

REGISTER 11-29: USBLPMR2: USB LINK POWER MANAGEMENT CONTROL REGISTER 2

| Bit Range | Bit 31/23/15/7 | Bit 30/22/14/6 | Bit 29/21/13/5 | Bit 28/20/12/4 | Bit 27/19/11/3 | Bit 26/18/10/2 | Bit 25/17/9/1 | Bit 24/16/8/0 |
|-----------|----------------|----------------|-----------------|---------------------|--------------------|---------------------|--------------------|--------------------|
| 31:24 | U-0 — | U-0 — | U-0 — | U-0 — | U-0 — | U-0 — | U-0 — | U-0 — |
| 23:16 | U-0 — | U-0 — | U-0 — | U-0 — | U-0 — | U-0 — | U-0 — | U-0 — |
| 15:8 | U-0 — | R/W-0 | R/W-0 | R/W-0 | R/W-0 | R/W-0 | R/W-0 | R/W-0 |
| | LPMFADDR<6:0> | | | | | | | |
| 7:0 | U-0 — | U-0 — | R-0 LPMERRIF | R-0, HS LPMRESIF | R-0, HS LPMNCIF | R-0, HS LPMACKIF | R-0, HS LPMNYIF | R-0, HS LPMSTIF |

| | |
|-------------------|------------------------------------|
| Legend: | HS = Hardware Set |
| R = Readable bit | W = Writable bit |
| -n = Value at POR | '1' = Bit is set |
| | U = Unimplemented bit, read as '0' |
| | '0' = Bit is cleared |
| | x = Bit is unknown |

bit 31-15 **Unimplemented:** Read as '0'

bit 14-8 **LPMFADDR<6:0>:** LPM Payload Function Address bits
These bits contain the address of the LPM payload function.

bit 7-6 **Unimplemented:** Read as '0'

bit 5 **LPMERRIF:** LPM Error Interrupt Flag bit (*Device mode*)
1 = An LPM transaction was received that had a LINKSTATE field that is not supported. The response will be a STALL.
0 = No error condition

bit 4 **LPMRESIF:** LPM Resume Interrupt Flag bit
1 = The USB module has resumed (for any reason)
0 = No Resume condition

bit 3 **LPMNCIF:** LPM NC Interrupt Flag bit
When in *Device mode*:
1 = The USB module received a LPM transaction and responded with a NYET due to data pending in the RX FIFOs.
0 = No NC interrupt condition

When in *Host mode*:
1 = A LPM transaction is transmitted and the device responded with an ACK
0 = No NC interrupt condition

bit 2 **LPMACKIF:** LPM ACK Interrupt Flag bit
When in *Device mode*:
1 = A LPM transaction was received and the USB Module responded with an ACK
0 = No ACK interrupt condition

When in *Host mode*:
1 = The LPM transaction is transmitted and the device responds with an ACK
0 = No ACK interrupt condition

bit 1 **LPMNYIF:** LPM NYET Interrupt Flag bit
When in *Device mode*:
1 = A LPM transaction is received and the USB Module responded with a NYET
0 = No NYET interrupt flag

When in *Host mode*:
1 = A LPM transaction is transmitted and the device responded with an NYET
0 = No NYET interrupt flag

PIC32MZ Embedded Connectivity with Floating Point Unit (EF) Family

REGISTER 11-29: USBLPMR2: USB LINK POWER MANAGEMENT CONTROL REGISTER 2

bit 0 **LPMSTIF:** LPM STALL Interrupt Flag bit

When in *Device mode*:

1 = A LPM transaction was received and the USB Module responded with a STALL

0 = No Stall condition

When in *Host mode*:

1 = A LPM transaction was transmitted and the device responded with a STALL

0 = No Stall condition

PIC32MZ Embedded Connectivity with Floating Point Unit (EF) Family

REGISTER 11-30: USBRCNCON: USB CLOCK/RESET CONTROL REGISTER

| Bit Range | Bit 31/23/15/7 | Bit 30/22/14/6 | Bit 29/21/13/5 | Bit 28/20/12/4 | Bit 27/19/11/3 | Bit 26/18/10/2 | Bit 25/17/9/1 | Bit 24/16/8/0 |
|-----------|----------------|----------------|----------------|----------------|----------------|----------------|---------------|---------------|
| 31:24 | U-0 | U-0 | U-0 | U-0 | U-0 | R-0, HS, HC | R-0, HS, HC | R/W-1, HS |
| | — | — | — | — | — | USBIF | USBRF | USBWKUP |
| 23:16 | U-0 | U-0 | U-0 | U-0 | U-0 | U-0 | U-0 | U-0 |
| | — | — | — | — | — | — | — | — |
| 15:8 | r-1 | U-0 | U-0 | U-0 | U-0 | U-0 | R/W-0 | R/W-0 |
| | — | — | — | — | — | — | USB IDOVEN | USB IDVAL |
| 7:0 | R/W-0 | R/W-0 | R/W-0 | R/W-0 | R/W-0 | R/W-0 | R/W-0 | R/W-0 |
| | PHYIDEN | VBUS MONEN | ASVAL MONEN | BSVAL MONEN | SEND MONEN | USBIE | USBRIE | USB WKUPEN |

Legend:

R = Readable bit
-n = Value at POR

W = Writable bit
'1' = Bit is set

U = Unimplemented bit, read as '0'
'0' = Bit is cleared
x = Bit is unknown

bit 31-27 **Unimplemented:** Read as '0'

bit 26 **USBIF:** USB General Interrupt Flag bit
1 = An event on the USB Bus has occurred
0 = No interrupt from USB module or interrupts have not been enabled

bit 25 **USBRF:** USB Resume Flag bit
1 = Resume from Suspend state. Device wake-up activity can be started.
0 = No Resume activity detected during Suspend, or not in Suspend state

bit 24 **USBWK:** USB Activity Status bit
1 = Connect, disconnect, or other activity on USB detected since last cleared
0 = No activity detected on USB

Note: This bit should be cleared just prior to entering sleep, but it should be checked that no activity has already occurred on USB before actually entering sleep.

bit 23-14 **Unimplemented:** Read as '0'

bit 15 **Reserved:** Read as '1'

bit 14-10 **Unimplemented:** Read as '0'

bit 9 **USBIDOVEN:** USB ID Override Enable bit
1 = Enable use of USBIDVAL bit
0 = Disable use of USBIDVAL and instead use the PHY value

bit 8 **USBIDVAL:** USB ID Value bit
1 = ID override value is 1
0 = ID override value is 0

bit 7 **PHYIDEN:** PHY ID Monitoring Enable bit
1 = Enable monitoring of the ID bit from the USB PHY
0 = Disable monitoring of the ID bit from the USB PHY

bit 6 **VBUSMONEN:** VBUS Monitoring for OTG Enable bit
1 = Enable monitoring for VBUS in VBUS Valid range (between 4.4V and 4.75V)
0 = Disable monitoring for VBUS in VBUS Valid range

bit 5 **ASVALMONEN:** A-Device VBUS Monitoring for OTG Enable bit
1 = Enable monitoring for VBUS in Session Valid range for A-device (between 0.8V and 2.0V)
0 = Disable monitoring for VBUS in Session Valid range for A-device

bit 4 **BSVALMONEN:** B-Device VBUS Monitoring for OTG Enable bit
1 = Enable monitoring for VBUS in Session Valid range for B-device (between 0.8V and 4.0V)
0 = Disable monitoring for VBUS in Session Valid range for B-device

PIC32MZ Embedded Connectivity with Floating Point Unit (EF) Family

REGISTER 11-30: USBCRCON: USB CLOCK/RESET CONTROL REGISTER (CONTINUED)

- bit 3 **SENDMONEN:** Session End VBUS Monitoring for OTG Enable bit
 1 = Enable monitoring for VBUS in Session End range (between 0.2V and 0.8V)
 0 = Disable monitoring for VBUS in Session End range
- bit 2 **USBIE:** USB General Interrupt Enable bit
 1 = Enables general interrupt from USB module
 0 = Disables general interrupt from USB module
- bit 1 **USBRIE:** USB Resume Interrupt Enable bit
 1 = Enable remote resume from suspend Interrupt
 0 = Disable interrupt to a Remote Devices USB resume signaling
- bit 0 **USBWKUPEN:** USB Activity Detection Interrupt Enable bit
 1 = Enable interrupt for detection of activity on USB bus in Sleep mode
 0 = Disable interrupt for detection of activity on USB bus in Sleep mode

12.0 I/O PORTS

Note: This data sheet summarizes the features of the PIC32MZ EF family of devices. It is not intended to be a comprehensive reference source. To complement the information in this data sheet, refer to **Section 12. "I/O Ports"** (DS60001120) in the *"PIC32 Family Reference Manual"*, which is available from the Microchip web site (www.microchip.com/PIC32).

General purpose I/O pins are the simplest of peripherals. They allow the PIC32MZ EF family device to monitor and control other devices. To add flexibility and functionality, some pins are multiplexed with alternate function(s). These functions depend on which peripheral features are on the device. In general, when a peripheral is functioning, that pin may not be used as a general purpose I/O pin.

Some of the key features of the I/O ports are:

- Individual output pin open-drain enable/disable
- Individual input pin weak pull-up and pull-down
- Monitor selective inputs and generate interrupt when change in pin state is detected
- Operation during Sleep and Idle modes
- Fast bit manipulation using CLR, SET and INV registers

Figure 12-1 illustrates a block diagram of a typical multiplexed I/O port.

FIGURE 12-1: BLOCK DIAGRAM OF A TYPICAL MULTIPLEXED PORT STRUCTURE

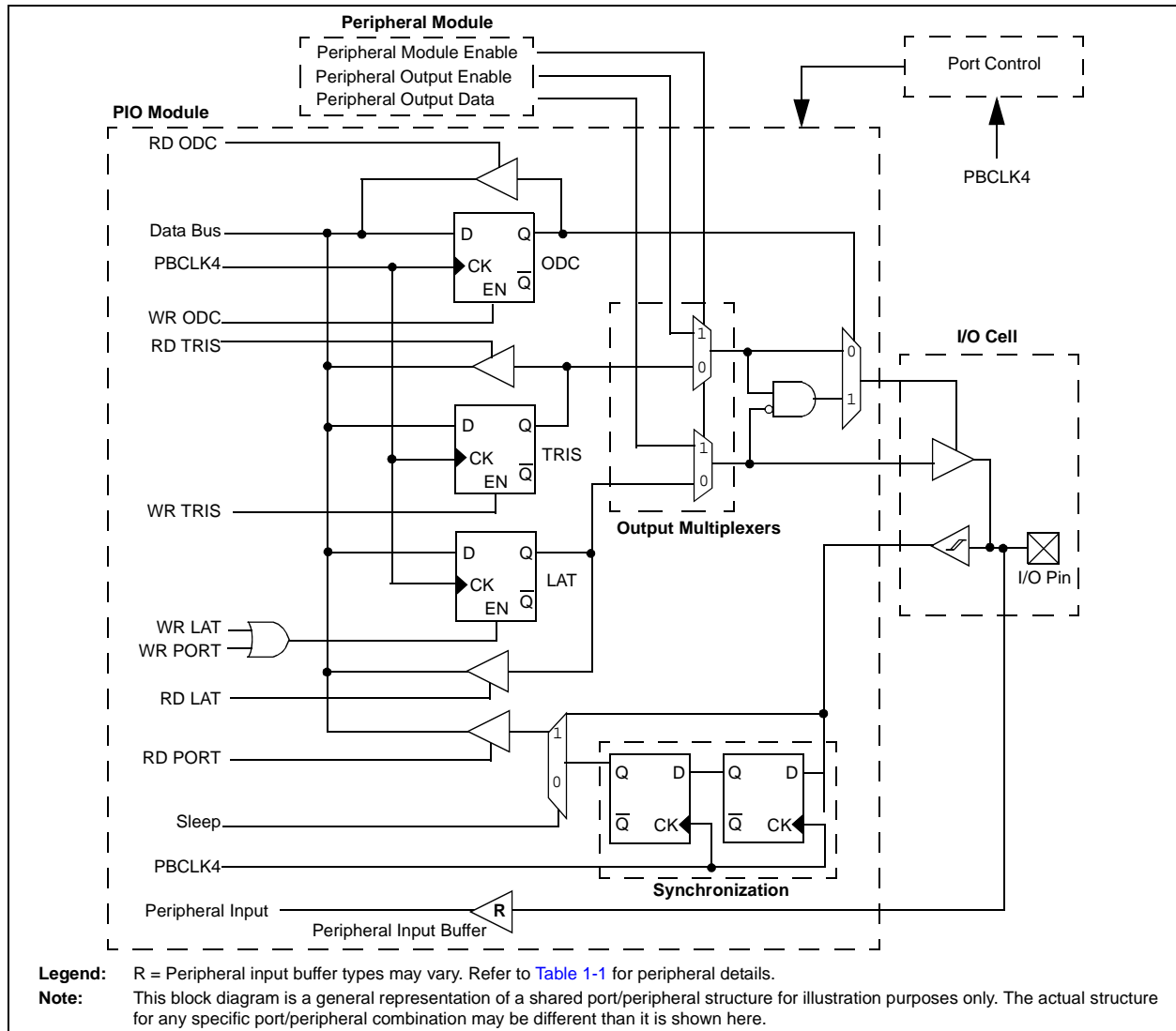

12.1 Parallel I/O (PIO) Ports

All port pins have up to 14 registers directly associated with their operation as digital I/O. The data direction register (TRISx) determines whether the pin is an input or an output. If the data direction bit is a '1', then the pin is an input. All port pins are defined as inputs after a Reset. Reads from the latch (LATx) read the latch. Writes to the latch write the latch. Reads from the port (PORTx) read the port pins, while writes to the port pins write the latch.

12.1.1 OPEN-DRAIN CONFIGURATION

In addition to the PORTx, LATx, and TRISx registers for data control, some port pins can also be individually configured for either digital or open-drain output. This is controlled by the Open-Drain Control register, ODCx, associated with each port. Setting any of the bits configures the corresponding pin to act as an open-drain output.

The open-drain feature allows the generation of outputs higher than VDD (e.g., 5V) on any desired 5V-tolerant pins by using external pull-up resistors. The maximum open-drain voltage allowed is the same as the maximum VIH specification.

Refer to the pin name tables (Table 2 through Table 5) for the available pins and their functionality.

12.1.2 CONFIGURING ANALOG AND DIGITAL PORT PINS

The ANSELx register controls the operation of the analog port pins. The port pins that are to function as analog inputs must have their corresponding ANSEL and TRIS bits set. In order to use port pins for I/O functionality with digital modules, such as Timers, UARTs, etc., the corresponding ANSELx bit must be cleared.

The ANSELx register has a default value of 0xFFFF; therefore, all pins that share analog functions are analog (not digital) by default.

If the TRIS bit is cleared (output) while the ANSELx bit is set, the digital output level (VOH or VOL) is converted by an analog peripheral, such as the ADC module or Comparator module.

When the PORT register is read, all pins configured as analog input channels are read as cleared (a low level).

Pins configured as digital inputs do not convert an analog input. Analog levels on any pin defined as a digital input (including the ANx pins) can cause the input buffer to consume current that exceeds the device specifications.

12.1.3 I/O PORT WRITE/READ TIMING

One instruction cycle is required between a port direction change or port write operation and a read operation of the same port. Typically this instruction would be an NOP.

12.1.4 INPUT CHANGE NOTIFICATION

The input change notification function of the I/O ports allows the PIC32MZ EF devices to generate interrupt requests to the processor in response to a change-of-state on selected input pins. This feature can detect input change-of-states even in Sleep mode, when the clocks are disabled. Every I/O port pin can be selected (enabled) for generating an interrupt request on a change-of-state.

Five control registers are associated with the CN functionality of each I/O port. The CNENx registers contain the CN interrupt enable control bits for each of the input pins. Setting any of these bits enables a CN interrupt for the corresponding pins.

The CNSTATx register indicates whether a change occurred on the corresponding pin since the last read of the PORTx bit.

Each I/O pin also has a weak pull-up and a weak pull-down connected to it. The pull-ups act as a current source or sink source connected to the pin, and eliminate the need for external resistors when push-button or keypad devices are connected. The pull-ups and pull-downs are enabled separately using the CNPUx and the CNPDx registers, which contain the control bits for each of the pins. Setting any of the control bits enables the weak pull-ups and/or pull-downs for the corresponding pins.

Note: Pull-ups and pull-downs on change notification pins should always be disabled when the port pin is configured as a digital output.

An additional control register (CNCONx) is shown in Register 12-3.

12.2 Registers for Slew Rate Control

Some I/O pins can be configured for various types of slew rate control on its associated port. This is controlled by the Slew Rate Control bits in the SRCON1x and SRCON0x registers that are associated with each I/O port. The slew rate control is configured using the corresponding bit in each register, as shown in Table 12-1.

As an example, writing 0x0001, 0x0000 to SRCON1A and SRCON0A, respectively, will enable slew rate control on the RAO pin and sets the slew rate to the slow edge rate.

TABLE 12-1: SLEW RATE CONTROL BIT SETTINGS

| SRCON1x | SRCON0x | Description |
|---------|---------|--|
| 1 | 1 | Slew rate control is enabled and is set to the slowest edge rate. |
| 1 | 0 | Slew rate control is enabled and is set to the slow edge rate. |
| 0 | 1 | Slew rate control is enabled and is set to the medium edge rate. |
| 0 | 0 | Slew rate control is disabled and is set to the fastest edge rate. |

Note: By default, all of the Port pins are set to the fastest edge rate.

12.3 CLR, SET, and INV Registers

Every I/O module register has a corresponding CLR (clear), SET (set) and INV (invert) register designed to provide fast atomic bit manipulations. As the name of the register implies, a value written to a SET, CLR or INV register effectively performs the implied operation, but only on the corresponding base register and only bits specified as '1' are modified. Bits specified as '0' are not modified.

Reading SET, CLR and INV registers returns undefined values. To see the affects of a write operation to a SET, CLR or INV register, the base register must be read.

12.4 Peripheral Pin Select (PPS)

A major challenge in general purpose devices is providing the largest possible set of peripheral features while minimizing the conflict of features on I/O pins. The challenge is even greater on low pin-count devices. In an application where more than one peripheral needs to be assigned to a single pin, inconvenient workarounds in application code or a complete redesign may be the only option.

PPS configuration provides an alternative to these choices by enabling peripheral set selection and their placement on a wide range of I/O pins. By increasing the pinout options available on a particular device, users can better tailor the device to their entire application, rather than trimming the application to fit the device.

The PPS configuration feature operates over a fixed subset of digital I/O pins. Users may independently map the input and/or output of most digital peripherals to these I/O pins. PPS is performed in software and generally does not require the device to be reprogrammed. Hardware safeguards are included that prevent accidental or spurious changes to the peripheral mapping once it has been established.

12.4.1 AVAILABLE PINS

The number of available pins is dependent on the particular device and its pin count. Pins that support the PPS feature include the designation "RPn" in their full pin designation, where "RP" designates a remappable peripheral and "n" is the remappable port number.

12.4.2 AVAILABLE PERIPHERALS

The peripherals managed by the PPS are all digital-only peripherals. These include general serial communications (UART, SPI, and CAN), general purpose timer clock inputs, timer-related peripherals (input capture and output compare), interrupt-on-change inputs, and reference clocks (input and output).

In comparison, some digital-only peripheral modules are never included in the PPS feature. This is because the peripheral's function requires special I/O circuitry on a specific port and cannot be easily connected to multiple pins. These modules include I²C among others. A similar requirement excludes all modules with analog inputs, such as the Analog-to-Digital Converter (ADC).

A key difference between remappable and non-remappable peripherals is that remappable peripherals are not associated with a default I/O pin. The peripheral must always be assigned to a specific I/O pin before it can be used. In contrast, non-remappable peripherals are always available on a default pin, assuming that the peripheral is active and not conflicting with another peripheral.

When a remappable peripheral is active on a given I/O pin, it takes priority over all other digital I/O and digital communication peripherals associated with the pin. Priority is given regardless of the type of peripheral that is mapped. Remappable peripherals never take priority over any analog functions associated with the pin.

12.4.3 CONTROLLING PPS

PPS features are controlled through two sets of SFRs: one to map peripheral inputs, and one to map outputs. Because they are separately controlled, a particular peripheral's input and output (if the peripheral has both) can be placed on any selectable function pin without constraint.

The association of a peripheral to a peripheral-selectable pin is handled in two different ways, depending on whether an input or output is being mapped.

12.4.4 INPUT MAPPING

The inputs of the PPS options are mapped on the basis of the peripheral. That is, a control register associated with a peripheral dictates the pin it will be mapped to. The $[pin\ name]R$ registers, where $[pin\ name]$ refers to the peripheral pins listed in Table 12-2, are used to configure peripheral input mapping (see Register 12-1). Each register contains sets of 4 bit fields. Programming these bit fields with an appropriate value maps the RPn pin with the corresponding value to that peripheral. For any given device, the valid range of values for any bit field is shown in Table 12-2.

For example, Figure 12-2 illustrates the remappable pin selection for the U1RX input.

FIGURE 12-2: REMAPPABLE INPUT EXAMPLE FOR U1RX

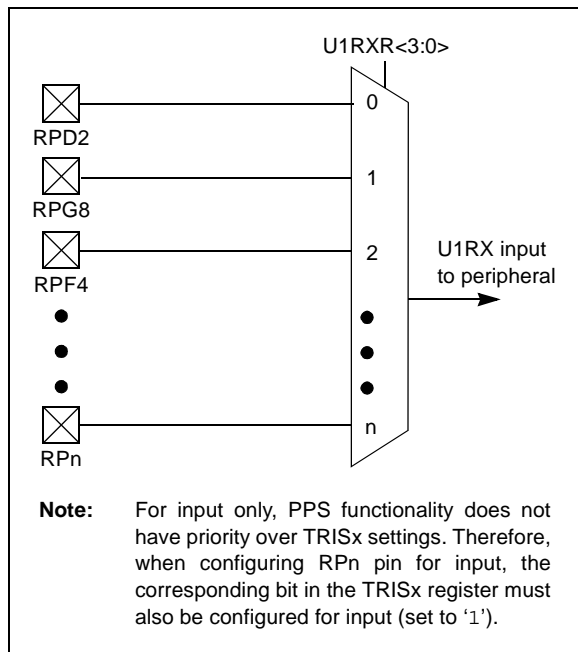

PIC32MZ Embedded Connectivity with Floating Point Unit (EF) Family

TABLE 12-2: INPUT PIN SELECTION

| Peripheral Pin | [pin name]R SFR | [pin name]R bits | [pin name]R Value to RPN Pin Selection |
|---------------------|----------------------|---------------------------|--|
| INT3 | INT3R | INT3R<3:0> | 0000 = RPD2 |
| T2CK | T2CKR | T2CKR<3:0> | 0001 = RPG8 |
| T6CK | T6CKR | T6CKR<3:0> | 0010 = RPF4 |
| IC3 | IC3R | IC3R<3:0> | 0011 = RPD10 |
| IC7 | IC7R | IC7R<3:0> | 0100 = RPF1 |
| U1RX | U1RXR | U1RXR<3:0> | 0101 = RPB9 |
| U2CTS | U2CTSR | U2CTSR<3:0> | 0110 = RPB10 |
| U5RX | U5RXR | U5RXR<3:0> | 0111 = RPC14 |
| U6CTS | U6CTSR | U6CTSR<3:0> | 1000 = RPB5 |
| SDI1 | SDI1R | SDI1R<3:0> | 1001 = Reserved |
| SDI3 | SDI3R | SDI3R<3:0> | 1010 = RPC1 ⁽¹⁾ |
| SDI5 ⁽¹⁾ | SDI5R ⁽¹⁾ | SDI5R<3:0> ⁽¹⁾ | 1011 = RPD14 ⁽¹⁾ |
| SS6 ⁽¹⁾ | SS6R ⁽¹⁾ | SS6R<3:0> ⁽¹⁾ | 1100 = RPG1 ⁽¹⁾ |
| REFCLKI1 | REFCLKI1R | REFCLKI1R<3:0> | 1101 = RPA14 ⁽¹⁾ |
| | | | 1110 = RPD6 ⁽²⁾ |
| | | | 1111 = Reserved |
| INT4 | INT4R | INT4R<3:0> | 0000 = RPD3 |
| T5CK | T5CKR | T5CKR<3:0> | 0001 = RPG7 |
| T7CK | T7CKR | T7CKR<3:0> | 0010 = RPF5 |
| IC4 | IC4R | IC4R<3:0> | 0011 = RPD11 |
| IC8 | IC8R | IC8R<3:0> | 0100 = RPF0 |
| U3RX | U3RXR | U3RXR<3:0> | 0101 = RPB1 |
| U4CTS | U4CTSR | U4CTSR<3:0> | 0110 = RPE5 |
| SDI2 | SDI2R | SDI2R<3:0> | 0111 = RPC13 |
| SDI4 | SDI4R | SDI4R<3:0> | 1000 = RPB3 |
| C1RX ⁽³⁾ | C1RXR ⁽³⁾ | C1RXR<3:0> ⁽³⁾ | 1001 = Reserved |
| REFCLKI4 | REFCLKI4R | REFCLKI4R<3:0> | 1010 = RPC4 ⁽¹⁾ |
| | | | 1011 = RPD15 ⁽¹⁾ |
| | | | 1100 = RPG0 ⁽¹⁾ |
| | | | 1101 = RPA15 ⁽¹⁾ |
| | | | 1110 = RPD7 ⁽²⁾ |
| | | | 1111 = Reserved |
| INT2 | INT2R | INT2R<3:0> | 0000 = RPD9 |
| T3CK | T3CKR | T3CKR<3:0> | 0001 = RPG6 |
| T8CK | T8CKR | T8CKR<3:0> | 0010 = RPB8 |
| IC2 | IC2R | IC2R<3:0> | 0011 = RPB15 |
| IC5 | IC5R | IC5R<3:0> | 0100 = RPD4 |
| IC9 | IC9R | IC9R<3:0> | 0101 = RPB0 |
| U1CTS | U1CTSR | U1CTSR<3:0> | 0110 = RPE3 |
| U2RX | U2RXR | U2RXR<3:0> | 0111 = RPB7 |
| U5CTS | U5CTSR | U5CTSR<3:0> | 1000 = Reserved |
| SS1 | SS1R | SS1R<3:0> | 1001 = RPF12 ⁽¹⁾ |
| SS3 | SS3R | SS3R<3:0> | 1010 = RPD12 ⁽¹⁾ |
| SS4 | SS4R | SS4R<3:0> | 1011 = RPF8 ⁽¹⁾ |
| SS5 ⁽¹⁾ | SS5R ⁽¹⁾ | SS5R<3:0> ⁽¹⁾ | 1100 = RPC3 ⁽¹⁾ |
| C2RX ⁽³⁾ | C2RXR ⁽³⁾ | C2RXR<3:0> ⁽³⁾ | 1101 = RPE9 ⁽¹⁾ |
| | | | 1110 = Reserved |
| | | | 1111 = Reserved |

- Note 1:** This selection is not available on 64-pin devices.
Note 2: This selection is not available on 64-pin or 100-pin devices.
Note 3: This selection is not available on devices without a CAN module.

PIC32MZ Embedded Connectivity with Floating Point Unit (EF) Family

TABLE 12-2: INPUT PIN SELECTION (CONTINUED)

| Peripheral Pin | [pin name]R SFR | [pin name]R bits | [pin name]R Value to RPN Pin Selection |
|---------------------|----------------------|---------------------------|--|
| INT1 | INT1R | INT1R<3:0> | 0000 = RPD1 |
| T4CK | T4CKR | T4CKR<3:0> | 0001 = RPG9 |
| T9CK | T9CKR | T9CKR<3:0> | 0010 = RPB14 |
| IC1 | IC1R | IC1R<3:0> | 0011 = RPD0 |
| IC6 | IC6R | IC6R<3:0> | 0100 = Reserved |
| U3CTS | U3CTSR | U3CTSR<3:0> | 0101 = RPB6 |
| U4RX | U4RXR | U4RXR<3:0> | 0110 = RPD5 |
| U6RX | U6RXR | U6RXR<3:0> | 0111 = RPB2 |
| SS2 | SS2R | SS2R<3:0> | 1000 = RPF3 |
| SDI6 ⁽¹⁾ | SDI6R ⁽¹⁾ | SDI6R<3:0> ⁽¹⁾ | 1001 = RPF13 ⁽¹⁾ |
| OCFA | OCFAR | OCFAR<3:0> | 1010 = No Connect |
| REFCLKI3 | REFCLKI3R | REFCLKI3R<3:0> | 1011 = RPF2 ⁽¹⁾ |
| | | | 1100 = RPC2 ⁽¹⁾ |
| | | | 1101 = RPE8 ⁽¹⁾ |
| | | | 1110 = Reserved |
| | | | 1111 = Reserved |

Note 1: This selection is not available on 64-pin devices.

2: This selection is not available on 64-pin or 100-pin devices.

3: This selection is not available on devices without a CAN module.

12.4.5 OUTPUT MAPPING

In contrast to inputs, the outputs of the PPS options are mapped on the basis of the pin. In this case, a control register associated with a particular pin dictates the peripheral output to be mapped. The RPNR registers (Register 12-2) are used to control output mapping. Like the $[pin\ name]R$ registers, each register contains sets of 4 bit fields. The value of the bit field corresponds to one of the peripherals, and that peripheral's output is mapped to the pin (see Table 12-3 and Figure 12-3).

A null output is associated with the output register reset value of '0'. This is done to ensure that remappable outputs remain disconnected from all output pins by default.

FIGURE 12-3: EXAMPLE OF MULTIPLEXING OF REMAPPABLE OUTPUT FOR RPF0

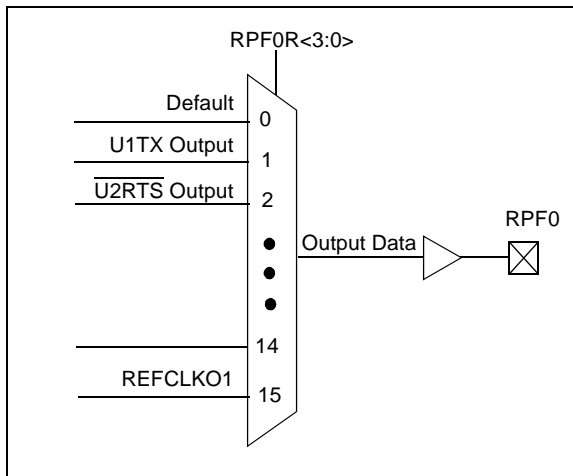

12.4.6 CONTROLLING CONFIGURATION CHANGES

Because peripheral remapping can be changed during run time, some restrictions on peripheral remapping are needed to prevent accidental configuration changes. PIC32MZ EF devices include two features to prevent alterations to the peripheral map:

- Control register lock sequence
- Configuration bit select lock

12.4.6.1 Control Register Lock

Under normal operation, writes to the RPNR and $[pin\ name]R$ registers are not allowed. Attempted writes appear to execute normally, but the contents of the registers remain unchanged. To change these registers, they must be unlocked in hardware. The register lock is controlled by the IOLOCK Configuration bit (CFGCON<13>). Setting IOLOCK prevents writes to the control registers; clearing IOLOCK allows writes.

To set or clear the IOLOCK bit, an unlock sequence must be executed. Refer to **Section 42. "Oscillators with Enhanced PLL"** in the "PIC32 Family Reference Manual" for details.

12.4.6.2 Configuration Bit Select Lock

As an additional level of safety, the device can be configured to prevent more than one write session to the RPNR and $[pin\ name]R$ registers. The IOL1WAY Configuration bit (DEVCFG3<29>) blocks the IOLOCK bit from being cleared after it has been set once. If IOLOCK remains set, the register unlock procedure does not execute, and the PPS control registers cannot be written to. The only way to clear the bit and re-enable peripheral remapping is to perform a device Reset.

In the default (unprogrammed) state, IOL1WAY is set, restricting users to one write session.

PIC32MZ Embedded Connectivity with Floating Point Unit (EF) Family

TABLE 12-3: OUTPUT PIN SELECTION

| RPn Port Pin | RPnR SFR | RPnR bits | RPnR Value to Peripheral Selection |
|----------------------|-----------------------|----------------------------|------------------------------------|
| RPD2 | RPD2R | RPD2R<3:0> | 0000 = No Connect |
| RPG8 | RPG8R | RPG8R<3:0> | 0001 = U3TX |
| RPF4 | RPF4R | RPF4R<3:0> | 0010 = U4RTS |
| RPD10 | RPD10R | RPD10R<3:0> | 0011 = Reserved |
| RPF1 | RPF1R | RPF1R<3:0> | 0100 = Reserved |
| RPB9 | RPB9R | RPB9R<3:0> | 0101 = SDO1 |
| RPB10 | RPB10R | RPB10R<3:0> | 0110 = SDO2 |
| RPC14 | RPC14R | RPC14R<3:0> | 0111 = SDO3 |
| RPB5 | RPB5R | RPB5R<3:0> | 1000 = Reserved |
| RPC1 ⁽¹⁾ | RPC1R ⁽¹⁾ | RPC1R<3:0> ⁽¹⁾ | 1001 = SDO5 ⁽¹⁾ |
| RPD14 ⁽¹⁾ | RPD14R ⁽¹⁾ | RPD14R<3:0> ⁽¹⁾ | 1010 = SS6 ⁽¹⁾ |
| RPG1 ⁽¹⁾ | RPG1R ⁽¹⁾ | RPG1R<3:0> ⁽¹⁾ | 1011 = OC3 |
| RPA14 ⁽¹⁾ | RPA14R ⁽¹⁾ | RPA14R<3:0> ⁽¹⁾ | 1100 = OC6 |
| RPD6 ⁽²⁾ | RPD6R ⁽²⁾ | RPD6R<3:0> ⁽²⁾ | 1101 = REFCLKO4 |
| | | | 1110 = C2OUT |
| | | | 1111 = C1TX ⁽³⁾ |
| RPD3 | RPD3R | RPD3R<3:0> | 0000 = No Connect |
| RPG7 | RPG7R | RPG7R<3:0> | 0001 = U1TX |
| RPF5 | RPF5R | RPF5R<3:0> | 0010 = U2RTS |
| RPD11 | RPD11R | RPD11R<3:0> | 0011 = U5TX |
| RPF0 | RPF0R | RPF0R<3:0> | 0100 = U6RTS |
| RPB1 | RPB1R | RPB1R<3:0> | 0101 = SDO1 |
| RPE5 | RPE5R | RPE5R<3:0> | 0110 = SDO2 |
| RPC13 | RPC13R | RPC13R<3:0> | 0111 = SDO3 |
| RPB3 | RPB3R | RPB3R<3:0> | 1000 = SDO4 |
| RPC4 ⁽¹⁾ | RPC4R ⁽¹⁾ | RPC4R<3:0> ⁽¹⁾ | 1001 = SDO5 ⁽¹⁾ |
| RPD15 ⁽¹⁾ | RPD15R ⁽¹⁾ | RPD15R<3:0> ⁽¹⁾ | 1010 = Reserved |
| RPG0 ⁽¹⁾ | RPG0R ⁽¹⁾ | RPG0R<3:0> ⁽¹⁾ | 1011 = OC4 |
| RPA15 ⁽¹⁾ | RPA15R ⁽¹⁾ | RPA15R<3:0> ⁽¹⁾ | 1100 = OC7 |
| RPD7 ⁽²⁾ | RPD7R ⁽²⁾ | RPD7R<3:0> ⁽²⁾ | 1101 = Reserved |
| | | | 1110 = Reserved |
| | | | 1111 = REFCLKO1 |
| RPD9 | RPD9R | RPD9R<3:0> | 0000 = No Connect |
| RPG6 | RPG6R | RPG6R<3:0> | 0001 = U3RTS |
| RPB8 | RPB8R | RPB8R<3:0> | 0010 = U4TX |
| RPB15 | RPB15R | RPB15R<3:0> | 0011 = Reserved |
| RPD4 | RPD4R | RPD4R<3:0> | 0100 = U6TX |
| RPB0 | RPB0R | RPB0R<3:0> | 0101 = SS1 |
| RPE3 | RPE3R | RPE3R<3:0> | 0110 = Reserved |
| RPB7 | RPB7R | RPB7R<3:0> | 0111 = SS3 |
| RPF12 ⁽¹⁾ | RPF12R ⁽¹⁾ | RPF12R<3:0> ⁽¹⁾ | 1000 = SS4 |
| RPD12 ⁽¹⁾ | RPD12R ⁽¹⁾ | RPD12R<3:0> ⁽¹⁾ | 1001 = SS5 ⁽¹⁾ |
| RPF8 ⁽¹⁾ | RPF8R ⁽¹⁾ | RPF8R<3:0> ⁽¹⁾ | 1010 = SDO6 ⁽¹⁾ |
| RPC3 ⁽¹⁾ | RPC3R ⁽¹⁾ | RPC3R<3:0> ⁽¹⁾ | 1011 = OC5 |
| RPE9 ⁽¹⁾ | RPE9R ⁽¹⁾ | RPE9R<3:0> ⁽¹⁾ | 1100 = OC8 |
| | | | 1101 = Reserved |
| | | | 1110 = C1OUT |
| | | | 1111 = REFCLKO3 |

Note 1: This selection is not available on 64-pin devices.

Note 2: This selection is not available on 64-pin or 100-pin devices.

Note 3: This selection is not available on devices without a CAN module.

PIC32MZ Embedded Connectivity with Floating Point Unit (EF) Family

TABLE 12-3: OUTPUT PIN SELECTION (CONTINUED)

| RPn Port Pin | RPnR SFR | RPnR bits | RPnR Value to Peripheral Selection |
|----------------------|-----------------------|----------------------------|------------------------------------|
| RPD1 | RPD1R | RPD1R<3:0> | 0000 = No Connect |
| RPG9 | RPG9R | RPG9R<3:0> | 0001 = U1RTS |
| RPB14 | RPB14R | RPB14R<3:0> | 0010 = U2TX |
| RPD0 | RPD0R | RPD0R<3:0> | 0011 = U5RTS |
| RPB6 | RPB6R | RPB6R<3:0> | 0100 = U6TX |
| RPD5 | RPD5R | RPD5R<3:0> | 0101 = Reserved |
| RPB2 | RPB2R | RPB2R<3:0> | 0110 = SS2 |
| RPF3 | RPF3R | RPF3R<3:0> | 0111 = Reserved |
| RPF13 ⁽¹⁾ | RPF13R ⁽¹⁾ | RPF13R<3:0> ⁽¹⁾ | 1000 = SDO4 |
| RPC2 ⁽¹⁾ | RPC2R ⁽¹⁾ | RPC2R<3:0> ⁽¹⁾ | 1001 = Reserved |
| RPE8 ⁽¹⁾ | RPE8R ⁽¹⁾ | RPE8R<3:0> ⁽¹⁾ | 1010 = SDO6 ⁽¹⁾ |
| RPF2 ⁽¹⁾ | RPF2R ⁽¹⁾ | RPF2R<3:0> ⁽¹⁾ | 1011 = OC2 |
| | | | 1100 = OC1 |
| | | | 1101 = OC9 |
| | | | 1110 = Reserved |
| | | | 1111 = C2TX ⁽³⁾ |

Note 1: This selection is not available on 64-pin devices.

2: This selection is not available on 64-pin or 100-pin devices.

3: This selection is not available on devices without a CAN module.

12.5 I/O Ports Control Registers

TABLE 12-4: PORTA REGISTER MAP FOR 100-PIN, 124-PIN, AND 144-PIN DEVICES ONLY

| Virtual Address (BF86_#) | Register Name ⁽¹⁾ | Bit Range | Bits | | | | | | | | | | | | | | | | All Resets |
|--------------------------|------------------------------|-----------|------------|------------|-------|-------|------------|------------|-----------|------|-----------|-----------|-----------|-----------|-----------|-----------|-----------|-----------|------------|
| | | | 31/15 | 30/14 | 29/13 | 28/12 | 27/11 | 26/10 | 25/9 | 24/8 | 23/7 | 22/6 | 21/5 | 20/4 | 19/3 | 18/2 | 17/1 | 16/0 | |
| 0000 | ANSELA | 31:16 | — | — | — | — | — | — | — | — | — | — | — | — | — | — | — | — | 0000 |
| | | 15:0 | — | — | — | — | — | ANSA10 | ANSA9 | — | — | — | ANSA5 | — | — | — | ANSA1 | ANSA0 | 0623 |
| 0010 | TRISA | 31:16 | — | — | — | — | — | — | — | — | — | — | — | — | — | — | — | — | 0000 |
| | | 15:0 | TRISA15 | TRISA14 | — | — | — | TRISA10 | TRISA9 | — | TRISA7 | TRISA6 | TRISA5 | TRISA4 | TRISA3 | TRISA2 | TRISA1 | TRISA0 | C6FF |
| 0020 | PORTA | 31:16 | — | — | — | — | — | — | — | — | — | — | — | — | — | — | — | — | 0000 |
| | | 15:0 | RA15 | RA14 | — | — | — | RA10 | RA9 | — | RA7 | RA6 | RA5 | RA4 | RA3 | RA2 | RA1 | RA0 | xxxx |
| 0030 | LATA | 31:16 | — | — | — | — | — | — | — | — | — | — | — | — | — | — | — | — | 0000 |
| | | 15:0 | LATA15 | LATA14 | — | — | — | LATA10 | LATA9 | — | LATA7 | LATA6 | LATA5 | LATA4 | LATA3 | LATA2 | LATA1 | LATA0 | xxxx |
| 0040 | ODCA | 31:16 | — | — | — | — | — | — | — | — | — | — | — | — | — | — | — | — | 0000 |
| | | 15:0 | ODCA15 | ODCA14 | — | — | — | ODCA10 | ODCA9 | — | ODCA7 | ODCA6 | ODCA5 | ODCA4 | ODCA3 | ODCA2 | ODCA1 | ODCA0 | 0000 |
| 0050 | CNPUA | 31:16 | — | — | — | — | — | — | — | — | — | — | — | — | — | — | — | — | 0000 |
| | | 15:0 | CNPUA15 | CNPUA14 | — | — | — | CNPUA10 | CNPUA9 | — | CNPUA7 | CNPUA6 | CNPUA5 | CNPUA4 | CNPUA3 | CNPUA2 | CNPUA1 | CNPUA0 | 0000 |
| 0060 | CNPDA | 31:16 | — | — | — | — | — | — | — | — | — | — | — | — | — | — | — | — | 0000 |
| | | 15:0 | CNPDA15 | CNPDA14 | — | — | — | CNPDA10 | CNPDA9 | — | CNPDA7 | CNPDA6 | CNPDA5 | CNPDA4 | CNPDA3 | CNPDA2 | CNPDA1 | CNPDA0 | 0000 |
| 0070 | CNCONA | 31:16 | — | — | — | — | — | — | — | — | — | — | — | — | — | — | — | — | 0000 |
| | | 15:0 | ON | — | SIDL | — | EDGEDETECT | — | — | — | — | — | — | — | — | — | — | — | 0000 |
| 0080 | CNENA | 31:16 | — | — | — | — | — | — | — | — | — | — | — | — | — | — | — | — | 0000 |
| | | 15:0 | CNENA15 | CNENA14 | — | — | — | CNENA10 | CNENA9 | — | CNENA7 | CNENA6 | CNENA5 | CNENA4 | CNENA3 | CNENA2 | CNENA1 | CNENA0 | 0000 |
| 0090 | CNSTATA | 31:16 | — | — | — | — | — | — | — | — | — | — | — | — | — | — | — | — | 0000 |
| | | 15:0 | CN STATA15 | CN STATA14 | — | — | — | CN STATA10 | CN STATA9 | — | CN STATA7 | CN STATA6 | CN STATA5 | CN STATA4 | CN STATA3 | CN STATA2 | CN STATA1 | CN STATA0 | 0000 |
| 00A0 | CNNEA | 31:16 | — | — | — | — | — | — | — | — | — | — | — | — | — | — | — | — | 0000 |
| | | 15:0 | CNNEA15 | CNNEA14 | — | — | — | CNNEA10 | CNNEA9 | — | CNNEA7 | CNNEA6 | CNNEA5 | CNNEA4 | CNNEA3 | CNNEA2 | CNNEA1 | CNNEA0 | 0000 |
| 00B0 | CNFA | 31:16 | — | — | — | — | — | — | — | — | — | — | — | — | — | — | — | — | 0000 |
| | | 15:0 | CNFA15 | CNFA14 | — | — | — | CNFA10 | CNFA9 | — | CNFA7 | CNFA76 | CNFA5 | CNFA4 | CNFA3 | CNFA2 | CNFA71 | CNFA0 | 0000 |
| 00C0 | SRCON0A | 31:16 | — | — | — | — | — | — | — | — | — | — | — | — | — | — | — | — | 0000 |
| | | 15:0 | — | — | — | — | — | — | — | — | SR0A7 | SR0A6 | — | — | — | — | — | — | 0000 |
| 00D0 | SRCON1A | 31:16 | — | — | — | — | — | — | — | — | — | — | — | — | — | — | — | — | 0000 |
| | | 15:0 | — | — | — | — | — | — | — | — | SR1A7 | SR0A6 | — | — | — | — | — | — | 0000 |

Legend: x = Unknown value on Reset; — = Unimplemented, read as '0'; Reset values are shown in hexadecimal.

Note 1: All registers in this table have corresponding CLR, SET and INV registers at its virtual address, plus an offset of 0x4, 0x8 and 0xC, respectively. See [Section 12.3 “CLR, SET, and INV Registers”](#) for more information.

TABLE 12-5: PORTB REGISTER MAP

| Virtual Address (BF86_#) | Register Name(*) | Bit Range | Bits | | | | | | | | | | | | | | | All Resets | |
|-----------------------------|---------------------|-----------|---------------|---------------|---------------|---------------|----------------|---------------|--------------|--------------|--------------|--------------|--------------|--------------|--------------|--------------|--------------|---------------|------|
| | | | 31/15 | 30/14 | 29/13 | 28/12 | 27/11 | 26/10 | 25/9 | 24/8 | 23/7 | 22/6 | 21/5 | 20/4 | 19/3 | 18/2 | 17/1 | | 16/0 |
| 0100 | ANSELB | 31:16 | — | — | — | — | — | — | — | — | — | — | — | — | — | — | — | — | 0000 |
| | | 15:0 | ANSB15 | ANSB14 | ANSB13 | ANSB12 | ANSB11 | ANSB10 | ANSB9 | ANSB8 | ANSB7 | ANSB6 | ANSB5 | ANSB4 | ANSB3 | ANSB2 | ANSB1 | ANSB0 | FFFF |
| 0110 | TRISB | 31:16 | — | — | — | — | — | — | — | — | — | — | — | — | — | — | — | — | 0000 |
| | | 15:0 | TRISB15 | TRISB14 | TRISB13 | TRISB12 | TRISB11 | TRISB10 | TRISB9 | TRISB8 | TRISB7 | TRISB6 | TRISB5 | TRISB4 | TRISB3 | TRISB2 | TRISB1 | TRISB0 | FFFF |
| 0120 | PORTB | 31:16 | — | — | — | — | — | — | — | — | — | — | — | — | — | — | — | — | 0000 |
| | | 15:0 | RB15 | RB14 | RB13 | RB12 | RB11 | RB10 | RB9 | RB8 | RB7 | RB6 | RB5 | RB4 | RB3 | RB2 | RB1 | RB0 | xxxx |
| 0130 | LATB | 31:16 | — | — | — | — | — | — | — | — | — | — | — | — | — | — | — | — | 0000 |
| | | 15:0 | LATB15 | LATB14 | LATB13 | LATB12 | LATB11 | LATB10 | LATB9 | LATB8 | LATB7 | LATB6 | LATB5 | LATB4 | LATB3 | LATB2 | LATB1 | LATB0 | xxxx |
| 0140 | ODCB | 31:16 | — | — | — | — | — | — | — | — | — | — | — | — | — | — | — | — | 0000 |
| | | 15:0 | ODCB15 | ODCB14 | ODCB13 | ODCB12 | ODCB11 | ODCB10 | ODCB9 | ODCB8 | ODCB7 | ODCB6 | ODCB5 | ODCB4 | ODCB3 | ODCB2 | ODCB1 | ODCB0 | 0000 |
| 0150 | CNPUB | 31:16 | — | — | — | — | — | — | — | — | — | — | — | — | — | — | — | — | 0000 |
| | | 15:0 | CNPUB15 | CNPUB14 | CNPUB13 | CNPUB12 | CNPUB11 | CNPUB10 | CNPUB9 | CNPUB8 | CNPUB7 | CNPUB6 | CNPUB5 | CNPUB4 | CNPUB3 | CNPUB2 | CNPUB1 | CNPUB0 | 0000 |
| 0160 | CNPDB | 31:16 | — | — | — | — | — | — | — | — | — | — | — | — | — | — | — | — | 0000 |
| | | 15:0 | CNPDB15 | CNPDB14 | CNPDB13 | CNPDB12 | CNPDB11 | CNPDB10 | CNPDB9 | CNPDB8 | CNPDB7 | CNPDB6 | CNPDB5 | CNPDB4 | CNPDB3 | CNPDB2 | CNPDB1 | CNPDB0 | 0000 |
| 0170 | CNCONB | 31:16 | — | — | — | — | — | — | — | — | — | — | — | — | — | — | — | — | 0000 |
| | | 15:0 | ON | — | SIDL | — | EDGE DETECT | — | — | — | — | — | — | — | — | — | — | — | 0000 |
| 0180 | CNENB | 31:16 | — | — | — | — | — | — | — | — | — | — | — | — | — | — | — | — | 0000 |
| | | 15:0 | CNENB15 | CNENB14 | CNENB13 | CNENB12 | CNENB11 | CNENB10 | CNENB9 | CNENB8 | CNENB7 | CNENB6 | CNENB5 | CNENB4 | CNENB3 | CNENB2 | CNENB1 | CNENB0 | 0000 |
| 0190 | CNSTATB | 31:16 | — | — | — | — | — | — | — | — | — | — | — | — | — | — | — | — | 0000 |
| | | 15:0 | CN STATB15 | CN STATB14 | CN STATB13 | CN STATB12 | CN STATB11 | CN STATB10 | CN STATB9 | CN STATB8 | CN STATB7 | CN STATB6 | CN STATB5 | CN STATB4 | CN STATB3 | CN STATB2 | CN STATB1 | CN STATB0 | 0000 |
| 01A0 | CNNEB | 31:16 | — | — | — | — | — | — | — | — | — | — | — | — | — | — | — | — | 0000 |
| | | 15:0 | CNNEB15 | CNNEB14 | CNNEB13 | CNNEB12 | CNNEB11 | CNNEB10 | CNNEB9 | CNNEB8 | CNNEB7 | CNNEB6 | CNNEB5 | CNNEB4 | CNNEB3 | CNNEB2 | CNNEB1 | CNNEB0 | 0000 |
| 01B0 | CNFB | 31:16 | — | — | — | — | — | — | — | — | — | — | — | — | — | — | — | — | 0000 |
| | | 15:0 | CNFB15 | CNFB14 | CNFB13 | CNFB12 | CNFB11 | CNFB10 | CNFB9 | CNFB8 | CNFB7 | CNFB6 | CNFB5 | CNFB4 | CNFB3 | CNFB2 | CNFB1 | CNFB0 | 0000 |
| 01C0 | SRCON0B | 31:16 | — | — | — | — | — | — | — | — | — | — | — | — | — | — | — | — | 0000 |
| | | 15:0 | — | SR0B14 | — | — | — | — | SR0B10 | SR0B9 | SR0B8 | — | — | SR0B5 | — | SR0B3 | — | — | 0000 |
| 01D0 | SRCON1B | 31:16 | — | — | — | — | — | — | — | — | — | — | — | — | — | — | — | — | 0000 |
| | | 15:0 | — | SR1B14 | — | — | — | — | SR1B10 | SR1B9 | SR1B8 | — | — | SR1B5 | — | SR1B3 | — | — | 0000 |

Legend: x = Unknown value on Reset; — = Unimplemented, read as '0'; Reset values are shown in hexadecimal.

Note 1: All registers in this table have corresponding CLR, SET and INV registers at its virtual address, plus an offset of 0x4, 0x8 and 0xC, respectively. See [Section 12.3 “CLR, SET, and INV Registers”](#) for more information.

TABLE 12-6: PORTC REGISTER MAP FOR 100-PIN, 124-PIN, AND 144-PIN DEVICES ONLY

| Virtual Address (BF86_#) | Register Name(r) | Bit Range | Bits | | | | | | | | | | | | | | | All Resets | |
|-----------------------------|---------------------|-----------|-----------|-----------|-----------|-----------|----------------|-------|------|------|------|------|------|------|----------|----------|----------|---------------|------|
| | | | 31/15 | 30/14 | 29/13 | 28/12 | 27/11 | 26/10 | 25/9 | 24/8 | 23/7 | 22/6 | 21/5 | 20/4 | 19/3 | 18/2 | 17/1 | | 16/0 |
| 0200 | ANSEL | 31:16 | — | — | — | — | — | — | — | — | — | — | — | — | — | — | — | — | 0000 |
| | | 15:0 | — | — | — | — | — | — | — | — | — | — | — | — | ANSC4 | ANSC3 | ANSC2 | ANSC1 | — |
| 0210 | TRISC | 31:16 | — | — | — | — | — | — | — | — | — | — | — | — | — | — | — | — | 0000 |
| | | 15:0 | TRISC15 | TRISC14 | TRISC13 | TRISC12 | — | — | — | — | — | — | — | — | TRISC4 | TRISC3 | TRISC2 | TRISC1 | — |
| 0220 | PORTC | 31:16 | — | — | — | — | — | — | — | — | — | — | — | — | — | — | — | — | 0000 |
| | | 15:0 | RC15 | RC14 | RC13 | RC12 | — | — | — | — | — | — | — | — | RC4 | RC3 | RC2 | RC1 | — |
| 0230 | LATC | 31:16 | — | — | — | — | — | — | — | — | — | — | — | — | — | — | — | — | 0000 |
| | | 15:0 | LATC15 | LATC14 | LATC13 | LATC12 | — | — | — | — | — | — | — | — | LATC4 | LATC3 | LATC2 | LATC1 | — |
| 0240 | ODCC | 31:16 | — | — | — | — | — | — | — | — | — | — | — | — | — | — | — | — | 0000 |
| | | 15:0 | ODCC15 | ODCC14 | ODCC13 | ODCC12 | — | — | — | — | — | — | — | — | ODCC4 | ODCC3 | ODCC2 | ODCC1 | — |
| 0250 | CNPUC | 31:16 | — | — | — | — | — | — | — | — | — | — | — | — | — | — | — | — | 0000 |
| | | 15:0 | CNPUC15 | CNPUC14 | CNPUC13 | CNPUC12 | — | — | — | — | — | — | — | — | CNPUC4 | CNPUC3 | CNPUC2 | CNPUC1 | — |
| 0260 | CNPDC | 31:16 | — | — | — | — | — | — | — | — | — | — | — | — | — | — | — | — | 0000 |
| | | 15:0 | CNPDC15 | CNPDC14 | CNPDC13 | CNPDC12 | — | — | — | — | — | — | — | — | CNPDC4 | CNPDC3 | CNPDC2 | CNPDC1 | — |
| 0270 | CNCONC | 31:16 | — | — | — | — | — | — | — | — | — | — | — | — | — | — | — | — | 0000 |
| | | 15:0 | ON | — | SIDL | — | EDGE DETECT | — | — | — | — | — | — | — | — | — | — | — | — |
| 0280 | CNENC | 31:16 | — | — | — | — | — | — | — | — | — | — | — | — | — | — | — | — | 0000 |
| | | 15:0 | CNENC15 | CNENC14 | CNENC13 | CNENC12 | — | — | — | — | — | — | — | — | CNENC4 | CNENC3 | CNENC2 | CNENC1 | — |
| 0290 | CNSTATC | 31:16 | — | — | — | — | — | — | — | — | — | — | — | — | — | — | — | — | 0000 |
| | | 15:0 | CNSTATC15 | CNSTATC14 | CNSTATC13 | CNSTATC12 | — | — | — | — | — | — | — | — | CNSTATC4 | CNSTATC3 | CNSTATC2 | CNSTATC1 | — |
| 02A0 | CNNEC | 31:16 | — | — | — | — | — | — | — | — | — | — | — | — | — | — | — | — | 0000 |
| | | 15:0 | CNNEC15 | CNNEC14 | CNNEC13 | CNNEC12 | — | — | — | — | — | — | — | — | CNNEC4 | CNNEC3 | CNNEC2 | CNNEC1 | — |
| 02B0 | CNFC | 31:16 | — | — | — | — | — | — | — | — | — | — | — | — | — | — | — | — | 0000 |
| | | 15:0 | CNFC15 | CNFC14 | CNFC13 | CNFC12 | — | — | — | — | — | — | — | — | CNFC4 | CNFC3 | CNFC2 | CNFC1 | — |

Legend: x = Unknown value on Reset; — = Unimplemented, read as '0'; Reset values are shown in hexadecimal.

Note 1: All registers in this table have corresponding CLR, SET and INV registers at its virtual address, plus an offset of 0x4, 0x8 and 0xC, respectively. See [Section 12.3 “CLR, SET, and INV Registers”](#) for more information.

TABLE 12-7: PORTC REGISTER MAP FOR 64-PIN DEVICES ONLY

| Virtual Address (BF86_#) | Register Name ⁽¹⁾ | Bit Range | Bits | | | | | | | | | | | | | | | All Resets | |
|--------------------------|------------------------------|-----------|-----------|-----------|-----------|-----------|-------------|-------|------|------|------|------|------|------|------|------|------|------------|------|
| | | | 31/15 | 30/14 | 29/13 | 28/12 | 27/11 | 26/10 | 25/9 | 24/8 | 23/7 | 22/6 | 21/5 | 20/4 | 19/3 | 18/2 | 17/1 | | 16/0 |
| 0210 | TRISC | 31:16 | — | — | — | — | — | — | — | — | — | — | — | — | — | — | — | — | 0000 |
| | | 15:0 | TRISC15 | TRISC14 | TRISC13 | TRISC12 | — | — | — | — | — | — | — | — | — | — | — | — | F000 |
| 0220 | PORTC | 31:16 | — | — | — | — | — | — | — | — | — | — | — | — | — | — | — | — | 0000 |
| | | 15:0 | RC15 | RC14 | RC13 | RC12 | — | — | — | — | — | — | — | — | — | — | — | — | xxxx |
| 0230 | LATC | 31:16 | — | — | — | — | — | — | — | — | — | — | — | — | — | — | — | — | 0000 |
| | | 15:0 | LATC15 | LATC14 | LATC13 | LATC12 | — | — | — | — | — | — | — | — | — | — | — | — | xxxx |
| 0240 | ODCC | 31:16 | — | — | — | — | — | — | — | — | — | — | — | — | — | — | — | — | 0000 |
| | | 15:0 | ODCC15 | ODCC14 | ODCC13 | ODCC12 | — | — | — | — | — | — | — | — | — | — | — | — | xxxx |
| 0250 | CNPUC | 31:16 | — | — | — | — | — | — | — | — | — | — | — | — | — | — | — | — | 0000 |
| | | 15:0 | CNPUC15 | CNPUC14 | CNPUC13 | CNPUC12 | — | — | — | — | — | — | — | — | — | — | — | — | 0000 |
| 0260 | CNPDC | 31:16 | — | — | — | — | — | — | — | — | — | — | — | — | — | — | — | — | 0000 |
| | | 15:0 | CNPDC15 | CNPDC14 | CNPDC13 | CNPDC12 | — | — | — | — | — | — | — | — | — | — | — | — | 0000 |
| 0270 | CNCONC | 31:16 | — | — | — | — | — | — | — | — | — | — | — | — | — | — | — | — | 0000 |
| | | 15:0 | ON | — | SIDL | — | EDGE DETECT | — | — | — | — | — | — | — | — | — | — | — | 0000 |
| 0280 | CNENC | 31:16 | — | — | — | — | — | — | — | — | — | — | — | — | — | — | — | — | 0000 |
| | | 15:0 | CNENC15 | CNENC14 | CNENC13 | CNENC12 | — | — | — | — | — | — | — | — | — | — | — | — | 0000 |
| 0290 | CNSTATC | 31:16 | — | — | — | — | — | — | — | — | — | — | — | — | — | — | — | — | 0000 |
| | | 15:0 | CNSTATC15 | CNSTATC14 | CNSTATC13 | CNSTATC12 | — | — | — | — | — | — | — | — | — | — | — | — | 0000 |
| 02A0 | CNNEC | 31:16 | — | — | — | — | — | — | — | — | — | — | — | — | — | — | — | — | 0000 |
| | | 15:0 | CNNEC15 | CNNEC14 | CNNEC13 | CNNEC12 | — | — | — | — | — | — | — | — | — | — | — | — | 0000 |
| 02B0 | CNFC | 31:16 | — | — | — | — | — | — | — | — | — | — | — | — | — | — | — | — | 0000 |
| | | 15:0 | CNFC15 | CNFC14 | CNFC13 | CNFC12 | — | — | — | — | — | — | — | — | — | — | — | — | 0000 |

Legend: x = Unknown value on Reset; — = Unimplemented, read as '0'; Reset values are shown in hexadecimal.

Note 1: All registers in this table have corresponding CLR, SET and INV registers at its virtual address, plus an offset of 0x4, 0x8 and 0xC, respectively. See [Section 12.3 “CLR, SET, and INV Registers”](#) for more information.

TABLE 12-8: PORTD REGISTER MAP FOR 124-PIN AND 144-PIN DEVICES ONLY

| Virtual Address (BF86_#) | Register Name(1) | Bit Range | Bits | | | | | | | | | | | | | | | All Resets | |
|-----------------------------|---------------------|-----------|---------------|---------------|---------------|---------------|----------------|---------------|--------------|------|--------------|--------------|--------------|--------------|--------------|--------------|--------------|---------------|-------|
| | | | 31/15 | 30/14 | 29/13 | 28/12 | 27/11 | 26/10 | 25/9 | 24/8 | 23/7 | 22/6 | 21/5 | 20/4 | 19/3 | 18/2 | 17/1 | | 16/0 |
| 0300 | ANSELD | 31:16 | — | — | — | — | — | — | — | — | — | — | — | — | — | — | — | — | 0000 |
| | | 15:0 | ANSD15 | ANSD14 | — | — | — | — | — | — | — | — | — | — | — | — | — | — | — |
| 0310 | TRISD | 31:16 | — | — | — | — | — | — | — | — | — | — | — | — | — | — | — | — | 0000 |
| | | 15:0 | TRISD15 | TRISD14 | TRISD13 | TRISD12 | TRISD11 | TRISD10 | TRISD9 | — | TRISD7 | TRISD6 | TRISD5 | TRISD4 | TRISD3 | TRISD2 | TRISD1 | TRISD0 | FEFF |
| 0320 | PORTD | 31:16 | — | — | — | — | — | — | — | — | — | — | — | — | — | — | — | — | 0000 |
| | | 15:0 | RD15 | RD14 | RD13 | RD12 | RD11 | RD10 | RD9 | — | RD7 | RD6 | RD5 | RD4 | RD3 | RD2 | RD1 | RD0 | xxxxx |
| 0330 | LATD | 31:16 | — | — | — | — | — | — | — | — | — | — | — | — | — | — | — | — | 0000 |
| | | 15:0 | LATD15 | LATD14 | LATD13 | LATD12 | LATD11 | LATD10 | LATD9 | — | LATD7 | LATD6 | LATD5 | LATD4 | LATD3 | LATD2 | LATD1 | LATD0 | xxxxx |
| 0340 | ODCD | 31:16 | — | — | — | — | — | — | — | — | — | — | — | — | — | — | — | — | 0000 |
| | | 15:0 | ODCD15 | ODCD14 | ODCD13 | ODCD12 | ODCD11 | ODCD10 | ODCD9 | — | ODCD7 | ODCD6 | ODCD5 | ODCD4 | ODCD3 | ODCD2 | ODCD1 | ODCD0 | 0000 |
| 0350 | CNPUD | 31:16 | — | — | — | — | — | — | — | — | — | — | — | — | — | — | — | — | 0000 |
| | | 15:0 | CNPUD15 | CNPUD14 | CNPUD13 | CNPUD12 | CNPUD11 | CNPUD10 | CNPUD9 | — | CNPUD7 | CNPUD6 | CNPUD5 | CNPUD4 | CNPUD3 | CNPUD2 | CNPUD1 | CNPUD0 | 0000 |
| 0360 | CNPDD | 31:16 | — | — | — | — | — | — | — | — | — | — | — | — | — | — | — | — | 0000 |
| | | 15:0 | CNPDD15 | CNPDD14 | CNPDD13 | CNPDD12 | CNPDD11 | CNPDD10 | CNPDD9 | — | CNPDD7 | CNPDD6 | CNPDD5 | CNPDD4 | CNPDD3 | CNPDD2 | CNPDD1 | CNPDD0 | 0000 |
| 0370 | CNCOND | 31:16 | — | — | — | — | — | — | — | — | — | — | — | — | — | — | — | — | 0000 |
| | | 15:0 | ON | — | SIDL | — | EDGE DETECT | — | — | — | — | — | — | — | — | — | — | — | 0000 |
| 0380 | CNEND | 31:16 | — | — | — | — | — | — | — | — | — | — | — | — | — | — | — | — | 0000 |
| | | 15:0 | CNEND15 | CNEND14 | CNEND13 | CNEND12 | CNEND11 | CNEND10 | CNEND9 | — | CNEND7 | CNEND6 | CNEND5 | CNEND4 | CNEND3 | CNEND2 | CNEND1 | CNEND0 | 0000 |
| 0390 | CNSTATD | 31:16 | — | — | — | — | — | — | — | — | — | — | — | — | — | — | — | — | 0000 |
| | | 15:0 | CN STATD15 | CN STATD14 | CN STATD13 | CN STATD12 | CN STATD11 | CN STATD10 | CN STATD9 | — | CN STATD7 | CN STATD6 | CN STATD5 | CN STATD4 | CN STATD3 | CN STATD2 | CN STATD1 | CN STATD0 | 0000 |
| 03A0 | CNNED | 31:16 | — | — | — | — | — | — | — | — | — | — | — | — | — | — | — | — | 0000 |
| | | 15:0 | CNNED15 | CNNED14 | CNNED13 | CNNED12 | CNNED11 | CNNED10 | CNNED9 | — | CNNED7 | CNNED6 | CNNED5 | CNNED4 | CNNED3 | CNNED2 | CNNED1 | CNNED0 | 0000 |
| 03B0 | CNFD | 31:16 | — | — | — | — | — | — | — | — | — | — | — | — | — | — | — | — | 0000 |
| | | 15:0 | CNFD15 | CNFD14 | CNFD13 | CNFD12 | CNFD11 | CNFD10 | CNFD9 | — | CNFD7 | CNFD6 | CNFD5 | CNFD4 | CNFD3 | CNFD2 | CNFD1 | CNFD0 | 0000 |

Legend: x = Unknown value on Reset; — = Unimplemented, read as '0'; Reset values are shown in hexadecimal.

Note 1: All registers in this table have corresponding CLR, SET and INV registers at its virtual address, plus an offset of 0x4, 0x8 and 0xC, respectively. See [Section 12.3 “CLR, SET, and INV Registers”](#) for more information.

TABLE 12-9: PORTD REGISTER MAP FOR 100-PIN DEVICES ONLY

| Virtual Address (BF86_#) | Register Name ⁽¹⁾ | Bit Range | Bits | | | | | | | | | | | | | | All Resets | |
|--------------------------|------------------------------|-----------|---------------|---------------|---------------|---------------|----------------|---------------|--------------|------|------|------|--------------|--------------|--------------|--------------|--------------|--------------|
| | | | 31/15 | 30/14 | 29/13 | 28/12 | 27/11 | 26/10 | 25/9 | 24/8 | 23/7 | 22/6 | 21/5 | 20/4 | 19/3 | 18/2 | | 17/1 |
| 0300 | ANSELD | 31:16 | — | — | — | — | — | — | — | — | — | — | — | — | — | — | — | 0000 |
| | | 15:0 | ANSD15 | ANSD14 | — | — | — | — | — | — | — | — | — | — | — | — | — | — |
| 0310 | TRISD | 31:16 | — | — | — | — | — | — | — | — | — | — | — | — | — | — | — | 0000 |
| | | 15:0 | TRISD15 | TRISD14 | TRISD13 | TRISD12 | TRISD11 | TRISD10 | TRISD9 | — | — | — | TRISD5 | TRISD4 | TRISD3 | TRISD2 | TRISD1 | TRISD0 |
| 0320 | PORTD | 31:16 | — | — | — | — | — | — | — | — | — | — | — | — | — | — | — | 0000 |
| | | 15:0 | RD15 | RD14 | RD13 | RD12 | RD11 | RD10 | RD9 | — | — | — | RD5 | RD4 | RD3 | RD2 | RD1 | RD0 |
| 0330 | LATD | 31:16 | — | — | — | — | — | — | — | — | — | — | — | — | — | — | — | 0000 |
| | | 15:0 | LATD15 | LATD14 | LATD13 | LATD12 | LATD11 | LATD10 | LATD9 | — | — | — | LATD5 | LATD4 | LATD3 | LATD2 | LATD1 | LATD0 |
| 0340 | ODCD | 31:16 | — | — | — | — | — | — | — | — | — | — | — | — | — | — | — | 0000 |
| | | 15:0 | ODCD15 | ODCD14 | ODCD13 | ODCD12 | ODCD11 | ODCD10 | ODCD9 | — | — | — | ODCD5 | ODCD4 | ODCD3 | ODCD2 | ODCD1 | ODCD0 |
| 0350 | CNPUD | 31:16 | — | — | — | — | — | — | — | — | — | — | — | — | — | — | — | 0000 |
| | | 15:0 | CNPUD15 | CNPUD14 | CNPUD13 | CNPUD12 | CNPUD11 | CNPUD10 | CNPUD9 | — | — | — | CNPUD5 | CNPUD4 | CNPUD3 | CNPUD2 | CNPUD1 | CNPUD0 |
| 0360 | CNPDD | 31:16 | — | — | — | — | — | — | — | — | — | — | — | — | — | — | — | 0000 |
| | | 15:0 | CNPDD15 | CNPDD14 | CNPDD13 | CNPDD12 | CNPDD11 | CNPDD10 | CNPDD9 | — | — | — | CNPDD5 | CNPDD4 | CNPDD3 | CNPDD2 | CNPDD1 | CNPDD0 |
| 0370 | CNCOND | 31:16 | — | — | — | — | — | — | — | — | — | — | — | — | — | — | — | 0000 |
| | | 15:0 | ON | — | SIDL | — | EDGE DETECT | — | — | — | — | — | — | — | — | — | — | 0000 |
| 0380 | CNEND | 31:16 | — | — | — | — | — | — | — | — | — | — | — | — | — | — | — | 0000 |
| | | 15:0 | CNEND15 | CNEND14 | CNEND13 | CNEND12 | CNEND11 | CNEND10 | CNEND9 | — | — | — | CNEND5 | CNEND4 | CNEND3 | CNEND2 | CNEND1 | CNEND0 |
| 0390 | CNSTATD | 31:16 | — | — | — | — | — | — | — | — | — | — | — | — | — | — | — | 0000 |
| | | 15:0 | CN STATD15 | CN STATD14 | CN STATD13 | CN STATD12 | CN STATD11 | CN STATD10 | CN STATD9 | — | — | — | CN STATD5 | CN STATD4 | CN STATD3 | CN STATD2 | CN STATD1 | CN STATD0 |
| 03A0 | CNNED | 31:16 | — | — | — | — | — | — | — | — | — | — | — | — | — | — | — | 0000 |
| | | 15:0 | CNNED15 | CNNED14 | CNNED13 | CNNED12 | CNNED11 | CNNED10 | CNNED9 | — | — | — | CNNED5 | CNNED4 | CNNED3 | CNNED2 | CNNED1 | CNNED0 |
| 03B0 | CNFD | 31:16 | — | — | — | — | — | — | — | — | — | — | — | — | — | — | — | 0000 |
| | | 15:0 | CNFD15 | CNFD14 | CNFD13 | CNFD12 | CNFD11 | CNFD10 | CNFD9 | — | — | — | CNFD5 | CNFD4 | CNFD3 | CNFD2 | CNFD1 | CNFD0 |

Legend: x = Unknown value on Reset; — = Unimplemented, read as '0'; Reset values are shown in hexadecimal.
Note 1: All registers in this table have corresponding CLR, SET and INV registers at its virtual address, plus an offset of 0x4, 0x8 and 0xC, respectively. See [Section 12.3 “CLR, SET, and INV Registers”](#) for more information.

TABLE 12-10: PORTD REGISTER MAP FOR 64-PIN DEVICES ONLY

| Virtual Address (BF86_#) | Register Name(1) | Bit Range | Bits | | | | | | | | | | | | | | | | All Resets |
|-----------------------------|---------------------|-----------|-------|-------|-------|-------|----------------|---------------|--------------|------|------|------|--------------|--------------|--------------|--------------|--------------|--------------|---------------|
| | | | 31/15 | 30/14 | 29/13 | 28/12 | 27/11 | 26/10 | 25/9 | 24/8 | 23/7 | 22/6 | 21/5 | 20/4 | 19/3 | 18/2 | 17/1 | 16/0 | |
| 0310 | TRISD | 31:16 | — | — | — | — | — | — | — | — | — | — | — | — | — | — | — | — | 0000 |
| | | 15:0 | — | — | — | — | TRISD11 | TRISD10 | TRISD9 | — | — | — | TRISD5 | TRISD4 | TRISD3 | TRISD2 | TRISD1 | TRISD0 | 0E3F |
| 0320 | PORTD | 31:16 | — | — | — | — | — | — | — | — | — | — | — | — | — | — | — | — | 0000 |
| | | 15:0 | — | — | — | — | RD11 | RD10 | RD9 | — | — | — | RD5 | RD4 | RD3 | RD2 | RD1 | RD0 | xxxx |
| 0330 | LATD | 31:16 | — | — | — | — | — | — | — | — | — | — | — | — | — | — | — | — | 0000 |
| | | 15:0 | — | — | — | — | LATD11 | LATD10 | LATD9 | — | — | — | LATD5 | LATD4 | LATD3 | LATD2 | LATD1 | LATD0 | xxxx |
| 0340 | ODCD | 31:16 | — | — | — | — | — | — | — | — | — | — | — | — | — | — | — | — | 0000 |
| | | 15:0 | — | — | — | — | ODCD11 | ODCD10 | ODCD9 | — | — | — | ODCD5 | ODCD4 | ODCD3 | ODCD2 | ODCD1 | ODCD0 | 0000 |
| 0350 | CNPUD | 31:16 | — | — | — | — | — | — | — | — | — | — | — | — | — | — | — | — | 0000 |
| | | 15:0 | — | — | — | — | CNPUD11 | CNPUD10 | CNPUD9 | — | — | — | CNPUD5 | CNPUD4 | CNPUD3 | CNPUD2 | CNPUD1 | CNPUD0 | 0000 |
| 0360 | CNPDD | 31:16 | — | — | — | — | — | — | — | — | — | — | — | — | — | — | — | — | 0000 |
| | | 15:0 | — | — | — | — | CNPDD11 | CNPDD10 | CNPDD9 | — | — | — | CNPDD5 | CNPDD4 | CNPDD3 | CNPDD2 | CNPDD1 | CNPDD0 | 0000 |
| 0370 | CNCOND | 31:16 | — | — | — | — | — | — | — | — | — | — | — | — | — | — | — | — | 0000 |
| | | 15:0 | ON | — | SIDL | — | EDGE DETECT | — | — | — | — | — | — | — | — | — | — | — | 0000 |
| 0380 | CNEND | 31:16 | — | — | — | — | — | — | — | — | — | — | — | — | — | — | — | — | 0000 |
| | | 15:0 | — | — | — | — | CNEND11 | CNEND10 | CNEND9 | — | — | — | CNEND5 | CNEND4 | CNEND3 | CNEND2 | CNEND1 | CNEND0 | 0000 |
| 0390 | CNSTATD | 31:16 | — | — | — | — | — | — | — | — | — | — | — | — | — | — | — | — | 0000 |
| | | 15:0 | — | — | — | — | CN STATD11 | CN STATD10 | CN STATD9 | — | — | — | CN STATD5 | CN STATD4 | CN STATD3 | CN STATD2 | CN STATD1 | CN STATD0 | 0000 |
| 03A0 | CNNED | 31:16 | — | — | — | — | — | — | — | — | — | — | — | — | — | — | — | — | 0000 |
| | | 15:0 | — | — | — | — | CNNED11 | CNNED10 | CNNED9 | — | — | — | CNNED5 | CNNED4 | CNNED3 | CNNED2 | CNNED1 | CNNED0 | 0000 |
| 03B0 | CNFD | 31:16 | — | — | — | — | — | — | — | — | — | — | — | — | — | — | — | — | 0000 |
| | | 15:0 | — | — | — | — | CNFD11 | CNFD10 | CNFD9 | — | — | — | CNFD5 | CNFD4 | CNFD3 | CNFD2 | CNFD1 | CNFD0 | 0000 |

Legend: x = Unknown value on Reset; — = Unimplemented, read as '0'; Reset values are shown in hexadecimal.

Note 1: All registers in this table have corresponding CLR, SET and INV registers at its virtual address, plus an offset of 0x4, 0x8 and 0xC, respectively. See [Section 12.3 “CLR, SET, and INV Registers”](#) for more information.

TABLE 12-11: PORTE REGISTER MAP FOR 100-PIN, 124-PIN, AND 144-PIN DEVICES ONLY

| Virtual Address (BF86_#) | Register Name ⁽¹⁾ | Bit Range | Bits | | | | | | | | | | | | | | | | All Resets |
|--------------------------|------------------------------|-----------|-------|-------|-------|-------|----------------|-------|--------------|--------------|--------------|--------------|--------------|--------------|--------------|--------------|--------------|--------------|------------|
| | | | 31/15 | 30/14 | 29/13 | 28/12 | 27/11 | 26/10 | 25/9 | 24/8 | 23/7 | 22/6 | 21/5 | 20/4 | 19/3 | 18/2 | 17/1 | 16/0 | |
| 0400 | ANSELE | 31:16 | — | — | — | — | — | — | — | — | — | — | — | — | — | — | — | — | 0000 |
| | | 15:0 | — | — | — | — | — | — | ANSE9 | ANSE8 | ANSE7 | ANSE6 | ANSE5 | ANSE4 | — | — | — | — | 03F0 |
| 0410 | TRISE | 31:16 | — | — | — | — | — | — | — | — | — | — | — | — | — | — | — | — | 0000 |
| | | 15:0 | — | — | — | — | — | — | TRISE9 | TRISE8 | TRISE7 | TRISE6 | TRISE5 | TRISE4 | TRISE3 | TRISE2 | TRISE1 | TRISE0 | 03FF |
| 0420 | PORTE | 31:16 | — | — | — | — | — | — | — | — | — | — | — | — | — | — | — | — | 0000 |
| | | 15:0 | — | — | — | — | — | — | RE9 | RE8 | RE7 | RE6 | RE5 | RE4 | RE3 | RE2 | RE1 | RE0 | xxxx |
| 0430 | LATE | 31:16 | — | — | — | — | — | — | — | — | — | — | — | — | — | — | — | — | 0000 |
| | | 15:0 | — | — | — | — | — | — | LATE9 | LATE8 | LATE7 | LATE6 | LATE5 | LATE4 | LATE3 | LATE2 | LATE1 | LATE0 | xxxx |
| 0440 | ODCE | 31:16 | — | — | — | — | — | — | — | — | — | — | — | — | — | — | — | — | 0000 |
| | | 15:0 | — | — | — | — | — | — | ODCE9 | ODCE8 | ODCE7 | ODCE6 | ODCE5 | ODCE4 | ODCE3 | ODCE2 | ODCE1 | ODCE0 | 0000 |
| 0450 | CNPUE | 31:16 | — | — | — | — | — | — | — | — | — | — | — | — | — | — | — | — | 0000 |
| | | 15:0 | — | — | — | — | — | — | CNPUE9 | CNPUE8 | CNPUE7 | CNPUE6 | CNPUE5 | CNPUE4 | CNPUE3 | CNPUE2 | CNPUE1 | CNPUE0 | 0000 |
| 0460 | CNPDE | 31:16 | — | — | — | — | — | — | — | — | — | — | — | — | — | — | — | — | 0000 |
| | | 15:0 | — | — | — | — | — | — | CNPDE9 | CNPDE8 | CNPDE7 | CNPDE6 | CNPDE5 | CNPDE4 | CNPDE3 | CNPDE2 | CNPDE1 | CNPDE0 | 0000 |
| 0470 | CNCONE | 31:16 | — | — | — | — | — | — | — | — | — | — | — | — | — | — | — | — | 0000 |
| | | 15:0 | ON | — | SIDL | — | EDGE DETECT | — | — | — | — | — | — | — | — | — | — | — | 0000 |
| 0480 | CNENE | 31:16 | — | — | — | — | — | — | — | — | — | — | — | — | — | — | — | — | 0000 |
| | | 15:0 | — | — | — | — | — | — | CNENE9 | CNENE8 | CNENE7 | CNENE6 | CNENE5 | CNENE4 | CNENE3 | CNENE2 | CNENE1 | CNENE0 | 0000 |
| 0490 | CNSTATE | 31:16 | — | — | — | — | — | — | — | — | — | — | — | — | — | — | — | — | 0000 |
| | | 15:0 | — | — | — | — | — | — | CN STATE9 | CN STATE8 | CN STATE7 | CN STATE6 | CN STATE5 | CN STATE4 | CN STATE3 | CN STATE2 | CN STATE1 | CN STATE0 | 0000 |
| 04A0 | CNNEE | 31:16 | — | — | — | — | — | — | — | — | — | — | — | — | — | — | — | — | 0000 |
| | | 15:0 | — | — | — | — | — | — | CNNEE9 | CNNEE8 | CNNEE7 | CNNEE6 | CNNEE5 | CNNEE4 | CNNEE3 | CNNEE2 | CNNEE1 | CNNEE0 | 0000 |
| 04B0 | CNFE | 31:16 | — | — | — | — | — | — | — | — | — | — | — | — | — | — | — | — | 0000 |
| | | 15:0 | — | — | — | — | — | — | CNFE9 | CNFE8 | CNFE7 | CNFE6 | CNFE5 | CNFE4 | CNFE3 | CNFE2 | CNFE1 | CNFE0 | 0000 |
| 04C0 | SRCON0E | 31:16 | — | — | — | — | — | — | — | — | — | — | — | — | — | — | — | — | 0000 |
| | | 15:0 | — | — | — | — | — | — | — | — | — | — | — | — | SR0E3 | SR0E2 | SR0E1 | SR0E0 | 0000 |
| 04D0 | SRCON1E | 31:16 | — | — | — | — | — | — | — | — | — | — | — | — | — | — | — | — | 0000 |
| | | 15:0 | — | — | — | — | — | — | — | — | — | — | — | — | SR1E3 | SR1E2 | SR1E1 | SR1E0 | 0000 |

Legend: x = Unknown value on Reset; — = Unimplemented, read as '0'; Reset values are shown in hexadecimal.
Note 1: All registers in this table have corresponding CLR, SET and INV registers at its virtual address, plus an offset of 0x4, 0x8 and 0xC, respectively. See [Section 12.3 “CLR, SET, and INV Registers”](#) for more information.

TABLE 12-12: PORTE REGISTER MAP FOR 64-PIN DEVICES ONLY

| Virtual Address (BF86_#) | Register Name ⁽¹⁾ | Bit Range | Bits | | | | | | | | | | | | | | | | All Resets |
|-----------------------------|---------------------------------|-----------|-------|-------|-------|-------|----------------|-------|------|------|--------------|--------------|--------------|--------------|--------------|--------------|--------------|--------------|---------------|
| | | | 31/15 | 30/14 | 29/13 | 28/12 | 27/11 | 26/10 | 25/9 | 24/8 | 23/7 | 22/6 | 21/5 | 20/4 | 19/3 | 18/2 | 17/1 | 16/0 | |
| 0400 | ANSELE | 31:16 | — | — | — | — | — | — | — | — | — | — | — | — | — | — | — | — | 0000 |
| | | 15:0 | — | — | — | — | — | — | — | — | ANSE7 | ANSE6 | ANSE5 | ANSE4 | — | — | — | — | 00F0 |
| 0410 | TRISE | 31:16 | — | — | — | — | — | — | — | — | — | — | — | — | — | — | — | — | 0000 |
| | | 15:0 | — | — | — | — | — | — | — | — | TRISE7 | TRISE6 | TRISE5 | TRISE4 | TRISE3 | TRISE2 | TRISE1 | TRISE0 | 00FF |
| 0420 | PORTE | 31:16 | — | — | — | — | — | — | — | — | — | — | — | — | — | — | — | — | 0000 |
| | | 15:0 | — | — | — | — | — | — | — | — | RE7 | RE6 | RE5 | RE4 | RE3 | RE2 | RE1 | RE0 | xxxx |
| 0430 | LATE | 31:16 | — | — | — | — | — | — | — | — | — | — | — | — | — | — | — | — | 0000 |
| | | 15:0 | — | — | — | — | — | — | — | — | LATE7 | LATE6 | LATE5 | LATE4 | LATE3 | LATE2 | LATE1 | LATE0 | xxxx |
| 0440 | ODCE | 31:16 | — | — | — | — | — | — | — | — | — | — | — | — | — | — | — | — | 0000 |
| | | 15:0 | — | — | — | — | — | — | — | — | ODCE7 | ODCE6 | ODCE5 | ODCE4 | ODCE3 | ODCE2 | ODCE1 | ODCE0 | 0000 |
| 0450 | CNPUE | 31:16 | — | — | — | — | — | — | — | — | — | — | — | — | — | — | — | — | 0000 |
| | | 15:0 | — | — | — | — | — | — | — | — | CNPUE7 | CNPUE6 | CNPUE5 | CNPUE4 | CNPUE3 | CNPUE2 | CNPUE1 | CNPUE0 | 0000 |
| 0460 | CNPDE | 31:16 | — | — | — | — | — | — | — | — | — | — | — | — | — | — | — | — | 0000 |
| | | 15:0 | — | — | — | — | — | — | — | — | CNPDE7 | CNPDE6 | CNPDE5 | CNPDE4 | CNPDE3 | CNPDE2 | CNPDE1 | CNPDE0 | 0000 |
| 0470 | CNCONE | 31:16 | — | — | — | — | — | — | — | — | — | — | — | — | — | — | — | — | 0000 |
| | | 15:0 | ON | — | SIDL | — | EDGE DETECT | — | — | — | — | — | — | — | — | — | — | — | 0000 |
| 0480 | CNENE | 31:16 | — | — | — | — | — | — | — | — | — | — | — | — | — | — | — | — | 0000 |
| | | 15:0 | — | — | — | — | — | — | — | — | CNENE7 | CNENE6 | CNENE5 | CNENE4 | CNENE3 | CNENE2 | CNENE1 | CNENE0 | 0000 |
| 0490 | CNSTATE | 31:16 | — | — | — | — | — | — | — | — | — | — | — | — | — | — | — | — | 0000 |
| | | 15:0 | — | — | — | — | — | — | — | — | CN STATE7 | CN STATE6 | CN STATE5 | CN STATE4 | CN STATE3 | CN STATE2 | CN STATE1 | CN STATE0 | 0000 |
| 04A0 | CNNEE | 31:16 | — | — | — | — | — | — | — | — | — | — | — | — | — | — | — | — | 0000 |
| | | 15:0 | — | — | — | — | — | — | — | — | CNNEE7 | CNNEE6 | CNNEE5 | CNNEE4 | CNNEE3 | CNNEE2 | CNNEE1 | CNNEE0 | 0000 |
| 04B0 | CNFE | 31:16 | — | — | — | — | — | — | — | — | — | — | — | — | — | — | — | — | 0000 |
| | | 15:0 | — | — | — | — | — | — | — | — | CNFE7 | CNFE6 | CNFE5 | CNFE4 | CNFE3 | CNFE2 | CNFE1 | CNFE0 | 0000 |
| 04C0 | SRCON0E | 31:16 | — | — | — | — | — | — | — | — | — | — | — | — | — | — | — | — | 0000 |
| | | 15:0 | — | — | — | — | — | — | — | — | — | — | — | — | SR0E3 | SR0E2 | SR0E1 | SR0E0 | 0000 |
| 04D0 | SRCON1E | 31:16 | — | — | — | — | — | — | — | — | — | — | — | — | — | — | — | — | 0000 |
| | | 15:0 | — | — | — | — | — | — | — | — | — | — | — | — | SR1E3 | SR1E2 | SR1E1 | SR1E0 | 0000 |

Legend: x = Unknown value on Reset; — = Unimplemented, read as '0'; Reset values are shown in hexadecimal.

Note 1: All registers in this table have corresponding CLR, SET and INV registers at its virtual address, plus an offset of 0x4, 0x8 and 0xC, respectively. See [Section 12.3 “CLR, SET, and INV Registers”](#) for more information.

TABLE 12-13: PORTF REGISTER MAP FOR 100-PIN, 124-PIN, AND 144-PIN DEVICES ONLY

| Virtual Address (BF86_#) | Register Name(1) | Bit Range | Bits | | | | | | | | | | | | | | | | All Resets |
|-----------------------------|---------------------|--------------|-------|-------|---------------|---------------|----------------|-------|------|--------------|------|------|--------------|--------------|--------------|--------------|--------------|--------------|---------------|
| | | | 31/15 | 30/14 | 29/13 | 28/12 | 27/11 | 26/10 | 25/9 | 24/8 | 23/7 | 22/6 | 21/5 | 20/4 | 19/3 | 18/2 | 17/1 | 16/0 | |
| 0500 | ANSELF | 31:16 | — | — | — | — | — | — | — | — | — | — | — | — | — | — | — | — | 0000 |
| | | 15:0 | — | — | ANSF13 | ANSF12 | — | — | — | — | — | — | — | — | — | — | — | — | — |
| 0510 | TRISF | 31:16 | — | — | — | — | — | — | — | — | — | — | — | — | — | — | — | — | 0000 |
| | | 15:0 | — | — | TRISF13 | TRISF12 | — | — | — | TRISF8 | — | — | TRISF5 | TRISF4 | TRISF3 | TRISF2 | TRISF1 | TRISF0 | 313F |
| 0520 | PORTF | 31:16 | — | — | — | — | — | — | — | — | — | — | — | — | — | — | — | — | 0000 |
| | | 15:0 | — | — | RF13 | RF12 | — | — | — | RF8 | — | — | RF5 | RF4 | RF3 | RF2 | RF1 | RF0 | xxxx |
| 0530 | LATF | 31:16 | — | — | — | — | — | — | — | — | — | — | — | — | — | — | — | — | 0000 |
| | | 15:0 | — | — | LATF13 | LATF12 | — | — | — | LATF8 | — | — | LATF5 | LATF4 | LATF3 | LATF2 | LATF1 | LATF0 | xxxx |
| 0540 | ODCF | 31:16 | — | — | — | — | — | — | — | — | — | — | — | — | — | — | — | — | 0000 |
| | | 15:0 | — | — | ODCF13 | ODCF12 | — | — | — | ODCF8 | — | — | ODCF5 | ODCF4 | ODCF3 | ODCF2 | ODCF1 | ODCF0 | 0000 |
| 0550 | CNPUF | 31:16 | — | — | — | — | — | — | — | — | — | — | — | — | — | — | — | — | 0000 |
| | | 15:0 | — | — | CNPUF13 | CNPUF12 | — | — | — | CNPUF8 | — | — | CNPUF5 | CNPUF4 | CNPUF3 | CNPUF2 | CNPUF1 | CNPUF0 | 0000 |
| 0560 | CNPDF | 31:16 | — | — | — | — | — | — | — | — | — | — | — | — | — | — | — | — | 0000 |
| | | 15:0 | — | — | CNPDF13 | CNPDF12 | — | — | — | CNPDF8 | — | — | CNPDF5 | CNPDF4 | CNPDF3 | CNPDF2 | CNPDF1 | CNPDF0 | 0000 |
| 0570 | CNCONF | 31:16 | — | — | — | — | — | — | — | — | — | — | — | — | — | — | — | — | 0000 |
| | | 15:0 | ON | — | SIDL | — | EDGE DETECT | — | — | — | — | — | — | — | — | — | — | — | 0000 |
| 0580 | CNENF | 31:16 | — | — | — | — | — | — | — | — | — | — | — | — | — | — | — | — | 0000 |
| | | 15:0 | — | — | CNENF13 | CNENF12 | — | — | — | CNENF8 | — | — | CNENF5 | CNENF4 | CNENF3 | CNENF2 | CNENF1 | CNENF0 | 0000 |
| 0590 | CNSTATF | 31:16 | — | — | — | — | — | — | — | — | — | — | — | — | — | — | — | — | 0000 |
| | | 15:0 | — | — | CN STATF13 | CN STATF12 | — | — | — | CN STATF8 | — | — | CN STATF5 | CN STATF4 | CN STATF3 | CN STATF2 | CN STATF1 | CN STATF0 | 0000 |
| 05A0 | CNNEF | 31:16 | — | — | — | — | — | — | — | — | — | — | — | — | — | — | — | — | 0000 |
| | | 15:0 | — | — | CNNEF13 | CNNEF12 | — | — | — | CNNEF8 | — | — | CNNEF5 | CNNEF4 | CNNEF3 | CNNEF2 | CNNEF1 | CNNEF0 | 0000 |
| 05B0 | CNFF | 31:16 | — | — | — | — | — | — | — | — | — | — | — | — | — | — | — | — | 0000 |
| | | 15:0 | — | — | CNFF13 | CNFF12 | — | — | — | CNFF8 | — | — | CNFF5 | CNFF4 | CNFF3 | CNFF2 | CNFF1 | CNFF0 | 0000 |
| 05C0 | SRCON0F | 31:16 | — | — | — | — | — | — | — | — | — | — | — | — | — | — | — | — | 0000 |
| | | 15:0 | — | — | — | — | — | — | — | — | — | — | — | — | — | — | SR0F1 | SR0F0 | 0000 |
| 05D0 | SRCON1F | 31:16 | — | — | — | — | — | — | — | — | — | — | — | — | — | — | — | — | 0000 |
| | | 15:0 | — | — | — | — | — | — | — | — | — | — | — | — | — | — | SR1F1 | SR1F0 | 0000 |

Legend: x = Unknown value on Reset; — = Unimplemented, read as '0'; Reset values are shown in hexadecimal.
Note 1: All registers in this table have corresponding CLR, SET and INV registers at its virtual address, plus an offset of 0x4, 0x8 and 0xC, respectively. See [Section 12.3 “CLR, SET, and INV Registers”](#) for more information.

TABLE 12-14: PORTF REGISTER MAP FOR 64-PIN DEVICES ONLY

| Virtual Address (BF86_#) | Register Name(1) | Bit Range | Bits | | | | | | | | | | | | | | | | All Resets |
|-----------------------------|---------------------|-----------|-------|-------|-------|-------|----------------|-------|------|------|------|------|--------------|--------------|--------------|------|--------------|--------------|---------------|
| | | | 31/15 | 30/14 | 29/13 | 28/12 | 27/11 | 26/10 | 25/9 | 24/8 | 23/7 | 22/6 | 21/5 | 20/4 | 19/3 | 18/2 | 17/1 | 16/0 | |
| 0510 | TRISF | 31:16 | — | — | — | — | — | — | — | — | — | — | — | — | — | — | — | — | 0000 |
| | | 15:0 | — | — | — | — | — | — | — | — | — | — | TRISF5 | TRISF4 | TRISF3 | — | TRISF1 | TRISF0 | 003B |
| 0520 | PORTF | 31:16 | — | — | — | — | — | — | — | — | — | — | — | — | — | — | — | — | 0000 |
| | | 15:0 | — | — | — | — | — | — | — | — | — | — | RF5 | RF4 | RF3 | — | RF1 | RF0 | xxxxx |
| 0530 | LATF | 31:16 | — | — | — | — | — | — | — | — | — | — | — | — | — | — | — | — | 0000 |
| | | 15:0 | — | — | — | — | — | — | — | — | — | — | LATF5 | LATF4 | LATF3 | — | LATF1 | LATF0 | xxxxx |
| 0540 | ODCF | 31:16 | — | — | — | — | — | — | — | — | — | — | — | — | — | — | — | — | 0000 |
| | | 15:0 | — | — | — | — | — | — | — | — | — | — | ODCF5 | ODCF4 | ODCF3 | — | ODCF1 | ODCF0 | 0000 |
| 0550 | CNPUF | 31:16 | — | — | — | — | — | — | — | — | — | — | — | — | — | — | — | — | 0000 |
| | | 15:0 | — | — | — | — | — | — | — | — | — | — | CNPUF5 | CNPUF4 | CNPUF3 | — | CNPUF1 | CNPUF0 | 0000 |
| 0560 | CNPDF | 31:16 | — | — | — | — | — | — | — | — | — | — | — | — | — | — | — | — | 0000 |
| | | 15:0 | — | — | — | — | — | — | — | — | — | — | CNPDF5 | CNPDF4 | CNPDF3 | — | CNPDF1 | CNPDF0 | 0000 |
| 0570 | CNCONF | 31:16 | — | — | — | — | — | — | — | — | — | — | — | — | — | — | — | — | 0000 |
| | | 15:0 | ON | — | SIDL | — | EDGE DETECT | — | — | — | — | — | — | — | — | — | — | — | 0000 |
| 0580 | CNENF | 31:16 | — | — | — | — | — | — | — | — | — | — | — | — | — | — | — | — | 0000 |
| | | 15:0 | — | — | — | — | — | — | — | — | — | — | CNENF5 | CNENF4 | CNENF3 | — | CNENF1 | CNENF0 | 0000 |
| 0590 | CNSTATF | 31:16 | — | — | — | — | — | — | — | — | — | — | — | — | — | — | — | — | 0000 |
| | | 15:0 | — | — | — | — | — | — | — | — | — | — | CN STATF5 | CN STATF4 | CN STATF3 | — | CN STATF1 | CN STATF0 | 0000 |
| 05A0 | CNNEF | 31:16 | — | — | — | — | — | — | — | — | — | — | — | — | — | — | — | — | 0000 |
| | | 15:0 | — | — | — | — | — | — | — | — | — | — | CNNEF5 | CNNEF4 | CNNEF3 | — | CNNEF1 | CNNEF0 | 0000 |
| 05B0 | CNFF | 31:16 | — | — | — | — | — | — | — | — | — | — | — | — | — | — | — | — | 0000 |
| | | 15:0 | — | — | — | — | — | — | — | — | — | — | CNFF5 | CNFF4 | CNFF3 | — | CNFF1 | CNFF0 | 0000 |
| 05C0 | SRCON0F | 31:16 | — | — | — | — | — | — | — | — | — | — | — | — | — | — | — | — | 0000 |
| | | 15:0 | — | — | — | — | — | — | — | — | — | — | — | — | — | — | SR0F1 | SR0F0 | 0000 |
| 05D0 | SRCON1F | 31:16 | — | — | — | — | — | — | — | — | — | — | — | — | — | — | — | — | 0000 |
| | | 15:0 | — | — | — | — | — | — | — | — | — | — | — | — | — | — | SR1F1 | SR2F0 | 0000 |

Legend: x = Unknown value on Reset; — = Unimplemented, read as '0'; Reset values are shown in hexadecimal.

Note 1: All registers in this table have corresponding CLR, SET and INV registers at its virtual address, plus an offset of 0x4, 0x8 and 0xC, respectively. See [Section 12.3 “CLR, SET, and INV Registers”](#) for more information.

TABLE 12-15: PORTG REGISTER MAP FOR 100-PIN, 124-PIN, AND 144-PIN DEVICES ONLY

| Virtual Address (BF86_#) | Register Name(1) | Bit Range | Bits | | | | | | | | | | | | | | | All Resets | |
|--------------------------|------------------|-----------|------------|------------|------------|------------|-------------|-------|-----------|-----------|-----------|-----------|-------|------|------|------|-----------|------------|------|
| | | | 31/15 | 30/14 | 29/13 | 28/12 | 27/11 | 26/10 | 25/9 | 24/8 | 23/7 | 22/6 | 21/5 | 20/4 | 19/3 | 18/2 | 17/1 | | 16/0 |
| 0600 | ANSELG | 31:16 | — | — | — | — | — | — | — | — | — | — | — | — | — | — | — | — | 0000 |
| | | 15:0 | ANSG15 | — | — | — | — | — | — | ANSG9 | ANSG8 | ANSG7 | ANSG6 | — | — | — | — | — | — |
| 0610 | TRISG | 31:16 | — | — | — | — | — | — | — | — | — | — | — | — | — | — | — | — | 0000 |
| | | 15:0 | TRISG15 | TRISG14 | TRISG13 | TRISG12 | — | — | TRISG9 | TRISG8 | TRISG7 | TRISG6 | — | — | — | — | TRISG1 | TRISG0 | F3C3 |
| 0620 | PORTG | 31:16 | — | — | — | — | — | — | — | — | — | — | — | — | — | — | — | — | 0000 |
| | | 15:0 | RG15 | RG14 | RG13 | RG12 | — | — | RG9 | RG8 | RG7 | RG6 | — | — | — | — | RG1 | RG0 | xxxx |
| 0630 | LATG | 31:16 | — | — | — | — | — | — | — | — | — | — | — | — | — | — | — | — | 0000 |
| | | 15:0 | LATG15 | LATG14 | LATG13 | LATG12 | — | — | LATG9 | LATG8 | LATG7 | LATG6 | — | — | — | — | LATG1 | LATG0 | xxxx |
| 0640 | ODCG | 31:16 | — | — | — | — | — | — | — | — | — | — | — | — | — | — | — | — | 0000 |
| | | 15:0 | ODCG15 | ODCG14 | ODCG13 | ODCG12 | — | — | ODCG9 | ODCG8 | ODCG7 | ODCG6 | — | — | — | — | ODCG1 | ODCG0 | 0000 |
| 0650 | CNPUG | 31:16 | — | — | — | — | — | — | — | — | — | — | — | — | — | — | — | — | 0000 |
| | | 15:0 | CNPUG15 | CNPUG14 | CNPUG13 | CNPUG12 | — | — | CNPUG9 | CNPUG8 | CNPUG7 | CNPUG6 | — | — | — | — | CNPUG1 | CNPUG0 | 0000 |
| 0660 | CNPDG | 31:16 | — | — | — | — | — | — | — | — | — | — | — | — | — | — | — | — | 0000 |
| | | 15:0 | CNPDG15 | CNPDG14 | CNPDG13 | CNPDG12 | — | — | CNPDG9 | CNPDG8 | CNPDG7 | CNPDG6 | — | — | — | — | CNPDG1 | CNPDG0 | 0000 |
| 0670 | CNCONG | 31:16 | — | — | — | — | — | — | — | — | — | — | — | — | — | — | — | — | 0000 |
| | | 15:0 | ON | — | SIDL | — | EDGE DETECT | — | — | — | — | — | — | — | — | — | — | — | 0000 |
| 0680 | CNENG | 31:16 | — | — | — | — | — | — | — | — | — | — | — | — | — | — | — | — | 0000 |
| | | 15:0 | CNENG15 | CNENG14 | CNENG13 | CNENG12 | — | — | CNENG9 | CNENG8 | CNENG7 | CNENG6 | — | — | — | — | CNENG1 | CNENG0 | 0000 |
| 0690 | CNSTATG | 31:16 | — | — | — | — | — | — | — | — | — | — | — | — | — | — | — | — | 0000 |
| | | 15:0 | CN STATG15 | CN STATG14 | CN STATG13 | CN STATG12 | — | — | CN STATG9 | CN STATG8 | CN STATG7 | CN STATG6 | — | — | — | — | CN STATG1 | CN STATG0 | 0000 |
| 06A0 | CNNEG | 31:16 | — | — | — | — | — | — | — | — | — | — | — | — | — | — | — | — | 0000 |
| | | 15:0 | CNNEG15 | CNNEG14 | CNNEG13 | CNNEG12 | — | — | CNNEG9 | CNNEG8 | CNNEG7 | CNNEG6 | — | — | — | — | CNNEG1 | CNNEG0 | 0000 |
| 06B0 | CNFG | 31:16 | — | — | — | — | — | — | — | — | — | — | — | — | — | — | — | — | 0000 |
| | | 15:0 | CNFG15 | CNFG14 | CNFG13 | CNFG12 | — | — | CNFG9 | CNFG8 | CNFG7 | CNFG6 | — | — | — | — | CNFG1 | CNFG0 | 0000 |
| 06C0 | SRCON0G | 31:16 | — | — | — | — | — | — | — | — | — | — | — | — | — | — | — | — | 0000 |
| | | 15:0 | — | SR0G14 | SR0G13 | SR0G12 | — | — | SR0G9 | — | — | SR0G6 | — | — | — | — | — | — | 0000 |
| 06D0 | SRCON1G | 31:16 | — | — | — | — | — | — | — | — | — | — | — | — | — | — | — | — | 0000 |
| | | 15:0 | — | SR1G14 | SR1G13 | SR1G12 | — | — | SR1G9 | — | — | SR1G6 | — | — | — | — | — | — | 0000 |

Legend: x = Unknown value on Reset; — = Unimplemented, read as '0'; Reset values are shown in hexadecimal.
Note 1: All registers in this table have corresponding CLR, SET and INV registers at its virtual address, plus an offset of 0x4, 0x8, and 0xC, respectively. See [Section 12.3 "CLR, SET, and INV Registers"](#) for more information.

TABLE 12-16: PORTG REGISTER MAP FOR 64-PIN DEVICES ONLY

| Virtual Address (BF86_#) | Register Name(1) | Bit Range | Bits | | | | | | | | | | | | | | All Resets | | |
|-----------------------------|---------------------|-----------|-------|-------|-------|-------|----------------|-------|------|--------------|--------------|--------------|--------------|------|------|------|---------------|------|------|
| | | | 31/15 | 30/14 | 29/13 | 28/12 | 27/11 | 26/10 | 25/9 | 24/8 | 23/7 | 22/6 | 21/5 | 20/4 | 19/3 | 18/2 | | 17/1 | 16/0 |
| 0600 | ANSELG | 31:16 | — | — | — | — | — | — | — | — | — | — | — | — | — | — | — | — | 0000 |
| | | 15:0 | — | — | — | — | — | — | — | ANSG9 | ANSG8 | ANSG7 | ANSG6 | — | — | — | — | — | 03C0 |
| 0610 | TRISG | 31:16 | — | — | — | — | — | — | — | — | — | — | — | — | — | — | — | 0000 | |
| | | 15:0 | — | — | — | — | — | — | — | TRISG9 | TRISG8 | TRISG7 | TRISG6 | — | — | — | — | 03C0 | |
| 0620 | PORTG | 31:16 | — | — | — | — | — | — | — | — | — | — | — | — | — | — | — | 0000 | |
| | | 15:0 | — | — | — | — | — | — | — | RG9 | RG8 | RG7 | RG6 | — | — | — | — | xxxx | |
| 0630 | LATG | 31:16 | — | — | — | — | — | — | — | — | — | — | — | — | — | — | — | 0000 | |
| | | 15:0 | — | — | — | — | — | — | — | LATG9 | LATG8 | LATG7 | LATG6 | — | — | — | — | xxxx | |
| 0640 | ODCG | 31:16 | — | — | — | — | — | — | — | — | — | — | — | — | — | — | — | 0000 | |
| | | 15:0 | — | — | — | — | — | — | — | ODCG9 | ODCG8 | ODCG7 | ODCG6 | — | — | — | — | 0000 | |
| 0650 | CNPUG | 31:16 | — | — | — | — | — | — | — | — | — | — | — | — | — | — | — | 0000 | |
| | | 15:0 | — | — | — | — | — | — | — | CNPUG9 | CNPUG8 | CNPUG7 | CNPUG6 | — | — | — | — | 0000 | |
| 0660 | CNPDG | 31:16 | — | — | — | — | — | — | — | — | — | — | — | — | — | — | — | 0000 | |
| | | 15:0 | — | — | — | — | — | — | — | CNPDG9 | CNPDG8 | CNPDG7 | CNPDG6 | — | — | — | — | 0000 | |
| 0670 | CNCONG | 31:16 | — | — | — | — | — | — | — | — | — | — | — | — | — | — | — | 0000 | |
| | | 15:0 | ON | — | SIDL | — | EDGE DETECT | — | — | — | — | — | — | — | — | — | — | 0000 | |
| 0680 | CNENG | 31:16 | — | — | — | — | — | — | — | — | — | — | — | — | — | — | — | 0000 | |
| | | 15:0 | — | — | — | — | — | — | — | CNENG9 | CNENG8 | CNENG7 | CNENG6 | — | — | — | — | 0000 | |
| 0690 | CNSTATG | 31:16 | — | — | — | — | — | — | — | — | — | — | — | — | — | — | — | 0000 | |
| | | 15:0 | — | — | — | — | — | — | — | CN STATG9 | CN STATG8 | CN STATG7 | CN STATG6 | — | — | — | — | 0000 | |
| 06A0 | CNNEG | 31:16 | — | — | — | — | — | — | — | — | — | — | — | — | — | — | — | 0000 | |
| | | 15:0 | — | — | — | — | — | — | — | CNNEG9 | CNNEG8 | CNNEG7 | CNNEG6 | — | — | — | — | 0000 | |
| 06B0 | CNFG | 31:16 | — | — | — | — | — | — | — | — | — | — | — | — | — | — | — | 0000 | |
| | | 15:0 | — | — | — | — | — | — | — | CNFG9 | CNFG8 | CNFG7 | CNFG6 | — | — | — | — | 0000 | |
| 06C0 | SRCON0G | 31:16 | — | — | — | — | — | — | — | — | — | — | — | — | — | — | — | 0000 | |
| | | 15:0 | — | — | — | — | — | — | — | SR0G9 | — | — | SR0G6 | — | — | — | — | 0000 | |
| 06D0 | SRCON1G | 31:16 | — | — | — | — | — | — | — | — | — | — | — | — | — | — | — | 0000 | |
| | | 15:0 | — | — | — | — | — | — | — | SR1G9 | — | — | SR1G6 | — | — | — | — | 0000 | |

Legend: x = Unknown value on Reset; — = Unimplemented, read as '0'; Reset values are shown in hexadecimal.

Note 1: All registers in this table have corresponding CLR, SET and INV registers at its virtual address, plus an offset of 0x4, 0x8 and 0xC, respectively. See [Section 12.3 “CLR, SET, and INV Registers”](#) for more information.

TABLE 12-17: PORTH REGISTER MAP FOR 124-PIN DEVICES ONLY

| Virtual Address (BF86_#) | Register Name ⁽¹⁾ | Bit Range | Bits | | | | | | | | | | | | | | All Resets | | |
|-----------------------------|---------------------------------|-----------|-------|-------|---------------|---------------|----------------|---------------|--------------|--------------|------|--------------|--------------|--------------|------|------|---------------|--------------|--------------|
| | | | 31/15 | 30/14 | 29/13 | 28/12 | 27/11 | 26/10 | 25/9 | 24/8 | 23/7 | 22/6 | 21/5 | 20/4 | 19/3 | 18/2 | | 17/1 | 16/0 |
| 0700 | ANSELH | 31:16 | — | — | — | — | — | — | — | — | — | — | — | — | — | — | — | — | 0000 |
| | | 15:0 | — | — | — | — | — | — | — | — | — | — | — | — | — | — | — | — | — |
| 0710 | TRISH | 31:16 | — | — | — | — | — | — | — | — | — | — | — | — | — | — | — | — | 0000 |
| | | 15:0 | — | — | TRISH13 | TRISH12 | — | TRISH10 | TRISH9 | TRISH8 | — | TRISH6 | TRISH5 | TRISH4 | — | — | — | TRISH1 | TRISH0 |
| 0720 | PORTH | 31:16 | — | — | — | — | — | — | — | — | — | — | — | — | — | — | — | — | 0000 |
| | | 15:0 | — | — | RH13 | RH12 | — | RH10 | RH9 | RH8 | — | RH6 | RH5 | RH4 | — | — | — | RH1 | RH0 |
| 0730 | LATH | 31:16 | — | — | — | — | — | — | — | — | — | — | — | — | — | — | — | — | 0000 |
| | | 15:0 | — | — | LATH13 | LATH12 | — | LATH10 | LATH9 | LATH8 | — | LATH6 | LATH5 | LATH4 | — | — | — | LATH1 | LATH0 |
| 0740 | ODCH | 31:16 | — | — | — | — | — | — | — | — | — | — | — | — | — | — | — | — | 0000 |
| | | 15:0 | — | — | ODCH13 | ODCH12 | — | ODCH10 | ODCH9 | ODCH8 | — | ODCH6 | ODCH5 | ODCH4 | — | — | — | ODCH1 | ODCH0 |
| 0750 | CNPUH | 31:16 | — | — | — | — | — | — | — | — | — | — | — | — | — | — | — | — | 0000 |
| | | 15:0 | — | — | CNPUH13 | CNPUH12 | — | CNPUH10 | CNPUH9 | CNPUH8 | — | CNPUH6 | CNPUH5 | CNPUH4 | — | — | — | CNPUH1 | CNPUH0 |
| 0760 | CNPDH | 31:16 | — | — | — | — | — | — | — | — | — | — | — | — | — | — | — | — | 0000 |
| | | 15:0 | — | — | CNPDH13 | CNPDH12 | — | CNPDH10 | CNPDH9 | CNPDH8 | — | CNPDH6 | CNPDH5 | CNPDH4 | — | — | — | CNPDH1 | CNPDH0 |
| 0770 | CNCONH | 31:16 | — | — | — | — | — | — | — | — | — | — | — | — | — | — | — | — | 0000 |
| | | 15:0 | ON | — | SIDL | — | EDGE DETECT | — | — | — | — | — | — | — | — | — | — | — | — |
| 0780 | CNENH | 31:16 | — | — | — | — | — | — | — | — | — | — | — | — | — | — | — | — | 0000 |
| | | 15:0 | — | — | CNENH13 | CNENH12 | — | CNENH10 | CNENH9 | CNENH8 | — | CNENH6 | CNENH5 | CNENH4 | — | — | — | CNENH1 | CNENH0 |
| 0790 | CNSTATH | 31:16 | — | — | — | — | — | — | — | — | — | — | — | — | — | — | — | — | 0000 |
| | | 15:0 | — | — | CN STATH13 | CN STATH12 | — | CN STATH10 | CN STATH9 | CN STATH8 | — | CN STATH6 | CN STATH5 | CN STATH4 | — | — | — | CN STATH1 | CN STATH0 |
| 07A0 | CNNEH | 31:16 | — | — | — | — | — | — | — | — | — | — | — | — | — | — | — | — | 0000 |
| | | 15:0 | — | — | CNNEH13 | CNNEH12 | — | CNNEH10 | CNNEH9 | CNNEH8 | — | CNNEH6 | CNNEH5 | CNNEH4 | — | — | — | CNNEH1 | CNNEH0 |
| 07B0 | CNFH | 31:16 | — | — | — | — | — | — | — | — | — | — | — | — | — | — | — | — | 0000 |
| | | 15:0 | — | — | CNFH13 | CNFH12 | — | CNFH10 | CNFH9 | CNFH8 | — | CNFH6 | CNFH5 | CNFH4 | — | — | — | CNFH1 | CNFH0 |

Legend: x = Unknown value on Reset; — = Unimplemented, read as '0'; Reset values are shown in hexadecimal.

Note 1: All registers in this table have corresponding CLR, SET and INV registers at its virtual address, plus an offset of 0x4, 0x8, and 0xC, respectively. See [Section 12.3 "CLR, SET, and INV Registers"](#) for more information.

TABLE 12-18: PORTH REGISTER MAP FOR 144-PIN DEVICES ONLY

| Virtual Address (BF86_#) | Register Name(1) | Bit Range | Bits | | | | | | | | | | | | | | | | All Resets |
|-----------------------------|---------------------|-----------|---------------|---------------|---------------|---------------|----------------|---------------|--------------|--------------|--------------|--------------|--------------|--------------|--------------|--------------|--------------|--------------|---------------|
| | | | 31/15 | 30/14 | 29/13 | 28/12 | 27/11 | 26/10 | 25/9 | 24/8 | 23/7 | 22/6 | 21/5 | 20/4 | 19/3 | 18/2 | 17/1 | 16/0 | |
| 0700 | ANSELH | 31:16 | — | — | — | — | — | — | — | — | — | — | — | — | — | — | — | — | 0000 |
| | | 15:0 | — | — | — | — | — | — | — | — | — | — | — | — | — | — | — | — | — |
| 0710 | TRISH | 31:16 | — | — | — | — | — | — | — | — | — | — | — | — | — | — | — | — | 0000 |
| | | 15:0 | TRISH15 | TRISH14 | TRISH13 | TRISH12 | TRISH11 | TRISH10 | TRISH9 | TRISH8 | TRISH7 | TRISH6 | TRISH5 | TRISH4 | TRISH3 | TRISH2 | TRISH1 | TRISH0 | FFFF |
| 0720 | PORTH | 31:16 | — | — | — | — | — | — | — | — | — | — | — | — | — | — | — | — | 0000 |
| | | 15:0 | RH15 | RH14 | RH13 | RH12 | RH11 | RH10 | RH9 | RH8 | RH7 | RH6 | RH5 | RH4 | RH3 | RH2 | RH1 | RH0 | xxxxx |
| 0730 | LATH | 31:16 | — | — | — | — | — | — | — | — | — | — | — | — | — | — | — | — | 0000 |
| | | 15:0 | LATH15 | LATH14 | LATH13 | LATH12 | LATH11 | LATH10 | LATH9 | LATH8 | LATH7 | LATH6 | LATH5 | LATH4 | LATH3 | LATH2 | LATH1 | LATH0 | xxxxx |
| 0740 | ODCH | 31:16 | — | — | — | — | — | — | — | — | — | — | — | — | — | — | — | — | 0000 |
| | | 15:0 | ODCH15 | ODCH14 | ODCH13 | ODCH12 | ODCH11 | ODCH10 | ODCH9 | ODCH8 | ODCH7 | ODCH6 | ODCH5 | ODCH4 | ODCH3 | ODCH2 | ODCH1 | ODCH0 | 0000 |
| 0750 | CNPUH | 31:16 | — | — | — | — | — | — | — | — | — | — | — | — | — | — | — | — | 0000 |
| | | 15:0 | CNPUH15 | CNPUH14 | CNPUH13 | CNPUH12 | CNPUH11 | CNPUH10 | CNPUH9 | CNPUH8 | CNPUH7 | CNPUH6 | CNPUH5 | CNPUH4 | CNPUH3 | CNPUH2 | CNPUH1 | CNPUH0 | 0000 |
| 0760 | CNPDH | 31:16 | — | — | — | — | — | — | — | — | — | — | — | — | — | — | — | — | 0000 |
| | | 15:0 | CNPDH15 | CNPDH14 | CNPDH13 | CNPDH12 | CNPDH11 | CNPDH10 | CNPDH9 | CNPDH8 | CNPDH7 | CNPDH6 | CNPDH5 | CNPDH4 | CNPDH3 | CNPDH2 | CNPDH1 | CNPDH0 | 0000 |
| 0770 | CNCONH | 31:16 | — | — | — | — | — | — | — | — | — | — | — | — | — | — | — | — | 0000 |
| | | 15:0 | ON | — | SIDL | — | EDGE DETECT | — | — | — | — | — | — | — | — | — | — | — | 0000 |
| 0780 | CNENH | 31:16 | — | — | — | — | — | — | — | — | — | — | — | — | — | — | — | — | 0000 |
| | | 15:0 | CNENH15 | CNENH14 | CNENH13 | CNENH12 | CNENH11 | CNENH10 | CNENH9 | CNENH8 | CNENH7 | CNENH6 | CNENH5 | CNENH4 | CNENH3 | CNENH2 | CNENH1 | CNENH0 | 0000 |
| 0790 | CNSTATH | 31:16 | — | — | — | — | — | — | — | — | — | — | — | — | — | — | — | — | 0000 |
| | | 15:0 | CN STATH15 | CN STATH14 | CN STATH13 | CN STATH12 | CN STATH11 | CN STATH10 | CN STATH9 | CN STATH8 | CN STATH7 | CN STATH6 | CN STATH5 | CN STATH4 | CN STATH3 | CN STATH2 | CN STATH1 | CN STATH0 | 0000 |
| 07A0 | CNNEH | 31:16 | — | — | — | — | — | — | — | — | — | — | — | — | — | — | — | — | 0000 |
| | | 15:0 | CNNEH15 | CNNEH14 | CNNEH13 | CNNEH12 | CNNEH11 | CNNEH10 | CNNEH9 | CNNEH8 | CNNEH7 | CNNEH6 | CNNEH5 | CNNEH4 | CNNEH3 | CNNEH2 | CNNEH1 | CNNEH0 | 0000 |
| 07B0 | CNFH | 31:16 | — | — | — | — | — | — | — | — | — | — | — | — | — | — | — | — | 0000 |
| | | 15:0 | CNFH15 | CNFH14 | CNFH13 | CNFH12 | CNFH11 | CNFH10 | CNFH9 | CNFH8 | CNFH7 | CNFH6 | CNFH5 | CNFH4 | CNFH3 | CNFH2 | CNFH1 | CNFH0 | 0000 |

Legend: x = Unknown value on Reset; — = Unimplemented, read as '0'; Reset values are shown in hexadecimal.

Note 1: All registers in this table have corresponding CLR, SET and INV registers at its virtual address, plus an offset of 0x4, 0x8, and 0xC, respectively. See [Section 12.3 "CLR, SET, and INV Registers"](#) for more information.

TABLE 12-19: PORTJ REGISTER MAP FOR 124-PIN DEVICES ONLY

| Virtual Address (BF86_#) | Register Name(s) | Bit Range | Bits | | | | | | | | | | | | | | | | All Resets |
|--------------------------|------------------|-----------|-------|-------|-------|-------|-------------|-------|-----------|-----------|------|------|------|-----------|------|-----------|-----------|-----------|------------|
| | | | 31/15 | 30/14 | 29/13 | 28/12 | 27/11 | 26/10 | 25/9 | 24/8 | 23/7 | 22/6 | 21/5 | 20/4 | 19/3 | 18/2 | 17/1 | 16/0 | |
| 0800 | ANSELJ | 31:16 | — | — | — | — | — | — | — | — | — | — | — | — | — | — | — | — | 0000 |
| | | 15:0 | — | — | — | — | ANSJ11 | — | ANSJ9 | ANSJ8 | — | — | — | — | — | — | — | — | 0B00 |
| 0810 | TRISJ | 31:16 | — | — | — | — | — | — | — | — | — | — | — | — | — | — | — | 0000 | |
| | | 15:0 | — | — | — | — | TRISJ11 | — | TRISJ9 | TRISJ8 | — | — | — | TRISJ4 | — | TRISJ2 | TRISJ1 | TRISJ0 | 0B17 |
| 0820 | PORTJ | 31:16 | — | — | — | — | — | — | — | — | — | — | — | — | — | — | — | 0000 | |
| | | 15:0 | — | — | — | — | RJ11 | — | RJ9 | RJ8 | — | — | — | RJ4 | — | RJ2 | RJ1 | RJ0 | xxxxx |
| 0830 | LATJ | 31:16 | — | — | — | — | — | — | — | — | — | — | — | — | — | — | — | 0000 | |
| | | 15:0 | — | — | — | — | LATJ11 | — | LATJ9 | LATJ8 | — | — | — | LATJ4 | — | LATJ2 | LATJ1 | LATJ0 | xxxxx |
| 0840 | ODCJ | 31:16 | — | — | — | — | — | — | — | — | — | — | — | — | — | — | — | 0000 | |
| | | 15:0 | — | — | — | — | ODCJ11 | — | ODCJ9 | ODCJ8 | — | — | — | ODCJ4 | — | ODCJ2 | ODCJ1 | ODCJ0 | 0000 |
| 0850 | CNPUJ | 31:16 | — | — | — | — | — | — | — | — | — | — | — | — | — | — | — | 0000 | |
| | | 15:0 | — | — | — | — | CNPUJ11 | — | CNPUJ9 | CNPUJ8 | — | — | — | CNPUJ4 | — | CNPUJ2 | CNPUJ1 | CNPUJ0 | 0000 |
| 0860 | CNPDJ | 31:16 | — | — | — | — | — | — | — | — | — | — | — | — | — | — | — | 0000 | |
| | | 15:0 | — | — | — | — | CNPDJ11 | — | CNPDJ9 | CNPDJ8 | — | — | — | CNPDJ4 | — | CNPDJ2 | CNPDJ1 | CNPDJ0 | 0000 |
| 0870 | CNCONJ | 31:16 | — | — | — | — | — | — | — | — | — | — | — | — | — | — | — | 0000 | |
| | | 15:0 | ON | — | SIDL | — | EDGE DETECT | — | — | — | — | — | — | — | — | — | — | 0000 | |
| 0880 | CNENJ | 31:16 | — | — | — | — | — | — | — | — | — | — | — | — | — | — | — | 0000 | |
| | | 15:0 | — | — | — | — | CNENJ11 | — | CNENJ9 | CNENJ8 | — | — | — | CNENJ4 | — | CNENJ2 | CNENJ1 | CNENJ0 | 0000 |
| 0890 | CNSTATJ | 31:16 | — | — | — | — | — | — | — | — | — | — | — | — | — | — | — | 0000 | |
| | | 15:0 | — | — | — | — | CN STATJ11 | — | CN STATJ9 | CN STATJ8 | — | — | — | CN STATJ4 | — | CN STATJ2 | CN STATJ1 | CN STATJ0 | 0000 |
| 08A0 | CNNEJ | 31:16 | — | — | — | — | — | — | — | — | — | — | — | — | — | — | — | 0000 | |
| | | 15:0 | — | — | — | — | CNNEJ11 | — | CNNEJ9 | CNNEJ8 | — | — | — | CNNEJ4 | — | CNNEJ2 | CNNEJ1 | CNNEJ0 | 0000 |
| 08B0 | CNFJ | 31:16 | — | — | — | — | — | — | — | — | — | — | — | — | — | — | — | 0000 | |
| | | 15:0 | — | — | — | — | CNFJ11 | — | CNFJ9 | CNFJ8 | — | — | — | CNFJ4 | — | CNFJ2 | CNFJ1 | CNFJ0 | 0000 |

Legend: x = Unknown value on Reset; — = Unimplemented, read as '0'; Reset values are shown in hexadecimal.
Note 1: All registers in this table have corresponding CLR, SET and INV registers at its virtual address, plus an offset of 0x4, 0x8, and 0xC, respectively. See [Section 12.3 "CLR, SET, and INV Registers"](#) for more information.

TABLE 12-20: PORTJ REGISTER MAP FOR 144-PIN DEVICES ONLY

| Virtual Address (BF86_#) | Register Name(s) | Bit Range | Bits | | | | | | | | | | | | | | | All Resets | |
|-----------------------------|---------------------|-----------|---------------|---------------|---------------|---------------|----------------|---------------|--------------|--------------|--------------|--------------|--------------|--------------|--------------|--------------|--------------|---------------|-------|
| | | | 31/15 | 30/14 | 29/13 | 28/12 | 27/11 | 26/10 | 25/9 | 24/8 | 23/7 | 22/6 | 21/5 | 20/4 | 19/3 | 18/2 | 17/1 | | 16/0 |
| 0800 | ANSELJ | 31:16 | — | — | — | — | — | — | — | — | — | — | — | — | — | — | — | — | 0000 |
| | | 15:0 | — | — | — | — | ANSJ11 | — | ANSJ9 | ANSJ8 | — | — | — | — | — | — | — | — | 0B00 |
| 0810 | TRISJ | 31:16 | — | — | — | — | — | — | — | — | — | — | — | — | — | — | — | — | 0000 |
| | | 15:0 | TRISJ15 | TRISJ14 | TRISJ13 | TRISJ12 | TRISJ11 | TRISJ10 | TRISJ9 | TRISJ8 | TRISJ7 | TRISJ6 | TRISJ5 | TRISJ4 | TRISJ3 | TRISJ2 | TRISJ1 | TRISJ0 | FFFF |
| 0820 | PORTJ | 31:16 | — | — | — | — | — | — | — | — | — | — | — | — | — | — | — | — | 0000 |
| | | 15:0 | RJ15 | RJ14 | RJ13 | RJ12 | RJ11 | RJ10 | RJ9 | RJ8 | RJ7 | RJ6 | RJ5 | RJ4 | RJ3 | RJ2 | RJ1 | RJ0 | xxxxx |
| 0830 | LATJ | 31:16 | — | — | — | — | — | — | — | — | — | — | — | — | — | — | — | — | 0000 |
| | | 15:0 | LATJ15 | LATJ14 | LATJ13 | LATJ12 | LATJ11 | LATJ10 | LATJ9 | LATJ8 | LATJ7 | LATJ6 | LATJ5 | LATJ4 | LATJ3 | LATJ2 | LATJ1 | LATJ0 | xxxxx |
| 0840 | ODCJ | 31:16 | — | — | — | — | — | — | — | — | — | — | — | — | — | — | — | — | 0000 |
| | | 15:0 | ODCJ15 | ODCJ14 | ODCJ13 | ODCJ12 | ODCJ11 | ODCJ10 | ODCJ9 | ODCJ18 | ODCJ7 | ODCJ6 | ODCJ5 | ODCJ4 | ODCJ3 | ODCJ2 | ODCJ1 | ODCJ0 | 0000 |
| 0850 | CNPUJ | 31:16 | — | — | — | — | — | — | — | — | — | — | — | — | — | — | — | — | 0000 |
| | | 15:0 | CNPUJ15 | CNPUJ14 | CNPUJ13 | CNPUJ12 | CNPUJ11 | CNPUJ10 | CNPUJ9 | CNPUJ8 | CNPUJ7 | CNPUJ6 | CNPUJ5 | CNPUJ4 | CNPUJ3 | CNPUJ2 | CNPUJ1 | CNPUJ0 | 0000 |
| 0860 | CNPDJ | 31:16 | — | — | — | — | — | — | — | — | — | — | — | — | — | — | — | — | 0000 |
| | | 15:0 | CNPDJ15 | CNPDJ14 | CNPDJ13 | CNPDJ12 | CNPDJ11 | CNPDJ10 | CNPDJ9 | CNPDJ8 | CNPDJ7 | CNPDJ6 | CNPDJ5 | CNPDJ4 | CNPDJ3 | CNPDJ2 | CNPDJ1 | CNPDJ0 | 0000 |
| 0870 | CNCONJ | 31:16 | — | — | — | — | — | — | — | — | — | — | — | — | — | — | — | — | 0000 |
| | | 15:0 | ON | — | SIDL | — | EDGE DETECT | — | — | — | — | — | — | — | — | — | — | — | 0000 |
| 0880 | CNENJ | 31:16 | — | — | — | — | — | — | — | — | — | — | — | — | — | — | — | — | 0000 |
| | | 15:0 | CNENJ15 | CNENJ14 | CNENJ13 | CNENJ12 | CNENJ11 | CNENJ10 | CNENJ9 | CNENJ8 | CNENJ7 | CNENJ6 | CNENJ5 | CNENJ4 | CNENJ3 | CNENJ2 | CNENJ1 | CNENJ0 | 0000 |
| 0890 | CNSTATJ | 31:16 | — | — | — | — | — | — | — | — | — | — | — | — | — | — | — | — | 0000 |
| | | 15:0 | CN STATJ15 | CN STATJ14 | CN STATJ13 | CN STATJ12 | CN STATJ11 | CN STATJ10 | CN STATJ9 | CN STATJ8 | CN STATJ7 | CN STATJ6 | CN STATJ5 | CN STATJ4 | CN STATJ3 | CN STATJ2 | CN STATJ1 | CN STATJ0 | 0000 |
| 08A0 | CNNEJ | 31:16 | — | — | — | — | — | — | — | — | — | — | — | — | — | — | — | — | 0000 |
| | | 15:0 | CNNEJ15 | CNNEJ14 | CNNEJ13 | CNNEJ12 | CNNEJ11 | CNNEJ10 | CNNEJ9 | CNNEJ8 | CNNEJ7 | CNNEJ6 | CNNEJ5 | CNNEJ4 | CNNEJ3 | CNNEJ2 | CNNEJ1 | CNNEJ0 | 0000 |
| 08B0 | CNFJ | 31:16 | — | — | — | — | — | — | — | — | — | — | — | — | — | — | — | — | 0000 |
| | | 15:0 | CNFJ15 | CNFJ14 | CNFJ13 | CNFJ12 | CNFJ11 | CNFJ10 | CNFJ9 | CNFJ8 | CNFJ7 | CNFJ6 | CNFJ5 | CNFJ4 | CNFJ3 | CNFJ2 | CNFJ1 | CNFJ0 | 0000 |

Legend: x = Unknown value on Reset; — = Unimplemented, read as '0'; Reset values are shown in hexadecimal.

Note 1: All registers in this table have corresponding CLR, SET and INV registers at its virtual address, plus an offset of 0x4, 0x8, and 0xC, respectively. See [Section 12.3 "CLR, SET, and INV Registers"](#) for more information.

TABLE 12-21: PORTK REGISTER MAP FOR 144-PIN DEVICES ONLY

| Virtual Address (BF86_#) | Register Name(1) | Bit Range | Bits | | | | | | | | | | | | | | | | All Resets |
|--------------------------|------------------|-----------|-------|-------|-------|-------|-------------|-------|------|------|-----------|-----------|-----------|-----------|-----------|-----------|-----------|-----------|------------|
| | | | 31/15 | 30/14 | 29/13 | 28/12 | 27/11 | 26/10 | 25/9 | 24/8 | 23/7 | 22/6 | 21/5 | 20/4 | 19/3 | 18/2 | 17/1 | 16/0 | |
| 0910 | TRISK | 31:16 | — | — | — | — | — | — | — | — | — | — | — | — | — | — | — | — | 0000 |
| | | 15:0 | — | — | — | — | — | — | — | — | TRISK7 | TRISK6 | TRISK5 | TRISK4 | TRISK3 | TRISK2 | TRISK1 | TRISK0 | 00FF |
| 0920 | PORTK | 31:16 | — | — | — | — | — | — | — | — | — | — | — | — | — | — | — | — | 0000 |
| | | 15:0 | — | — | — | — | — | — | — | — | RK7 | RK6 | RK5 | RK4 | RK3 | RK2 | RK1 | RK0 | xxxxx |
| 0930 | LATK | 31:16 | — | — | — | — | — | — | — | — | — | — | — | — | — | — | — | — | 0000 |
| | | 15:0 | — | — | — | — | — | — | — | — | LATK7 | LATK6 | LATK5 | LATK4 | LATK3 | LATK2 | LATK1 | LATK0 | xxxxx |
| 0940 | ODCK | 31:16 | — | — | — | — | — | — | — | — | — | — | — | — | — | — | — | — | 0000 |
| | | 15:0 | — | — | — | — | — | — | — | — | ODCK7 | ODCK6 | ODCK5 | ODCK4 | ODCK3 | ODCK2 | ODCK1 | ODCK0 | 0000 |
| 0950 | CNPUK | 31:16 | — | — | — | — | — | — | — | — | — | — | — | — | — | — | — | — | 0000 |
| | | 15:0 | — | — | — | — | — | — | — | — | CNPUK7 | CNPUK6 | CNPUK5 | CNPUK4 | CNPUK3 | CNPUK2 | CNPUK1 | CNPUK0 | 0000 |
| 0960 | CNPDK | 31:16 | — | — | — | — | — | — | — | — | — | — | — | — | — | — | — | — | 0000 |
| | | 15:0 | — | — | — | — | — | — | — | — | CNPDK7 | CNPDK6 | CNPDK5 | CNPDK4 | CNPDK3 | CNPDK2 | CNPDK1 | CNPDK0 | 0000 |
| 0970 | CNCONK | 31:16 | — | — | — | — | — | — | — | — | — | — | — | — | — | — | — | — | 0000 |
| | | 15:0 | ON | — | SIDL | — | EDGE DETECT | — | — | — | — | — | — | — | — | — | — | — | 0000 |
| 0980 | CNENK | 31:16 | — | — | — | — | — | — | — | — | — | — | — | — | — | — | — | — | 0000 |
| | | 15:0 | — | — | — | — | — | — | — | — | CNENK7 | CNENK6 | CNENK5 | CNENK4 | CNENK3 | CNENK2 | CNENK1 | CNENK0 | 0000 |
| 0990 | CNSTATK | 31:16 | — | — | — | — | — | — | — | — | — | — | — | — | — | — | — | — | 0000 |
| | | 15:0 | — | — | — | — | — | — | — | — | CN STATK7 | CN STATK6 | CN STATK5 | CN STATK4 | CN STATK3 | CN STATK2 | CN STATK1 | CN STATK0 | 0000 |
| 09A0 | CNNEK | 31:16 | — | — | — | — | — | — | — | — | — | — | — | — | — | — | — | — | 0000 |
| | | 15:0 | — | — | — | — | — | — | — | — | CNNEK7 | CNNEK6 | CNNEK5 | CNNEK4 | CNNEK3 | CNNEK2 | CNNEK1 | CNNEK0 | 0000 |
| 09B0 | CNFK | 31:16 | — | — | — | — | — | — | — | — | — | — | — | — | — | — | — | — | 0000 |
| | | 15:0 | — | — | — | — | — | — | — | — | CNFK7 | CNFK6 | CNFK5 | CNFK4 | CNFK3 | CNFK2 | CNFK1 | CNFK0 | 0000 |

Legend: x = Unknown value on Reset; — = Unimplemented, read as '0'; Reset values are shown in hexadecimal.
Note 1: All registers in this table have corresponding CLR, SET and INV registers at its virtual address, plus an offset of 0x4, 0x8, and 0xC, respectively. See [Section 12.3 “CLR, SET, and INV Registers”](#) for more information.

TABLE 12-22: PERIPHERAL PIN SELECT INPUT REGISTER MAP

| Virtual Address (BF60_#) | Register Name | Bit Range | Bits | | | | | | | | | | | | | | | All Resets | |
|-----------------------------|------------------|-----------|-------|-------|-------|-------|-------|-------|------|------|------|------|------|------|------------|------------|------|------------|------|
| | | | 31/15 | 30/14 | 29/13 | 28/12 | 27/11 | 26/10 | 25/9 | 24/8 | 23/7 | 22/6 | 21/5 | 20/4 | 19/3 | 18/2 | 17/1 | | 16/0 |
| 1404 | INT1R | 31:16 | — | — | — | — | — | — | — | — | — | — | — | — | — | — | — | — | 0000 |
| | | 15:0 | — | — | — | — | — | — | — | — | — | — | — | — | — | INT1R<3:0> | | | |
| 1408 | INT2R | 31:16 | — | — | — | — | — | — | — | — | — | — | — | — | — | — | — | — | 0000 |
| | | 15:0 | — | — | — | — | — | — | — | — | — | — | — | — | INT2R<3:0> | | | | |
| 140C | INT3R | 31:16 | — | — | — | — | — | — | — | — | — | — | — | — | — | — | — | — | 0000 |
| | | 15:0 | — | — | — | — | — | — | — | — | — | — | — | — | INT3R<3:0> | | | | |
| 1410 | INT4R | 31:16 | — | — | — | — | — | — | — | — | — | — | — | — | — | — | — | — | 0000 |
| | | 15:0 | — | — | — | — | — | — | — | — | — | — | — | — | INT4R<3:0> | | | | |
| 1418 | T2CKR | 31:16 | — | — | — | — | — | — | — | — | — | — | — | — | — | — | — | — | 0000 |
| | | 15:0 | — | — | — | — | — | — | — | — | — | — | — | — | T2CKR<3:0> | | | | |
| 141C | T3CKR | 31:16 | — | — | — | — | — | — | — | — | — | — | — | — | — | — | — | — | 0000 |
| | | 15:0 | — | — | — | — | — | — | — | — | — | — | — | — | T3CKR<3:0> | | | | |
| 1420 | T4CKR | 31:16 | — | — | — | — | — | — | — | — | — | — | — | — | — | — | — | — | 0000 |
| | | 15:0 | — | — | — | — | — | — | — | — | — | — | — | — | T4CKR<3:0> | | | | |
| 1424 | T5CKR | 31:16 | — | — | — | — | — | — | — | — | — | — | — | — | — | — | — | — | 0000 |
| | | 15:0 | — | — | — | — | — | — | — | — | — | — | — | — | T5CKR<3:0> | | | | |
| 1428 | T6CKR | 31:16 | — | — | — | — | — | — | — | — | — | — | — | — | — | — | — | — | 0000 |
| | | 15:0 | — | — | — | — | — | — | — | — | — | — | — | — | T6CKR<3:0> | | | | |
| 142C | T7CKR | 31:16 | — | — | — | — | — | — | — | — | — | — | — | — | — | — | — | — | 0000 |
| | | 15:0 | — | — | — | — | — | — | — | — | — | — | — | — | T7CKR<3:0> | | | | |
| 1430 | T8CKR | 31:16 | — | — | — | — | — | — | — | — | — | — | — | — | — | — | — | — | 0000 |
| | | 15:0 | — | — | — | — | — | — | — | — | — | — | — | — | T8CKR<3:0> | | | | |
| 1434 | T9CKR | 31:16 | — | — | — | — | — | — | — | — | — | — | — | — | — | — | — | — | 0000 |
| | | 15:0 | — | — | — | — | — | — | — | — | — | — | — | — | T9CKR<3:0> | | | | |
| 1438 | IC1R | 31:16 | — | — | — | — | — | — | — | — | — | — | — | — | — | — | — | — | 0000 |
| | | 15:0 | — | — | — | — | — | — | — | — | — | — | — | — | IC1R<3:0> | | | | |
| 143C | IC2R | 31:16 | — | — | — | — | — | — | — | — | — | — | — | — | — | — | — | — | 0000 |
| | | 15:0 | — | — | — | — | — | — | — | — | — | — | — | — | IC2R<3:0> | | | | |
| 1440 | IC3R | 31:16 | — | — | — | — | — | — | — | — | — | — | — | — | — | — | — | — | 0000 |
| | | 15:0 | — | — | — | — | — | — | — | — | — | — | — | — | IC3R<3:0> | | | | |

Legend: x = unknown value on Reset; — = unimplemented, read as '0'. Reset values are shown in hexadecimal.

- Note 1:** This register is not available on 64-pin devices.
Note 2: This register is not available on devices without a CAN module.

TABLE 12-22: PERIPHERAL PIN SELECT INPUT REGISTER MAP (CONTINUED)

| Virtual Address (BF80_#) | Register Name | Bit Range | Bits | | | | | | | | | | | | | | | All Resets |
|--------------------------|---------------|-----------|-------|-------|-------|-------|-------|-------|------|------|------|------|------|------|-------------|------|------|------------|
| | | | 31/15 | 30/14 | 29/13 | 28/12 | 27/11 | 26/10 | 25/9 | 24/8 | 23/7 | 22/6 | 21/5 | 20/4 | 19/3 | 18/2 | 17/1 | |
| 1444 | IC4R | 31:16 | — | — | — | — | — | — | — | — | — | — | — | — | — | — | — | 0000 |
| | | 15:0 | — | — | — | — | — | — | — | — | — | — | — | — | IC4R<3:0> | | | 0000 |
| 1448 | IC5R | 31:16 | — | — | — | — | — | — | — | — | — | — | — | — | — | — | — | 0000 |
| | | 15:0 | — | — | — | — | — | — | — | — | — | — | — | — | IC5R<3:0> | | | 0000 |
| 144C | IC6R | 31:16 | — | — | — | — | — | — | — | — | — | — | — | — | — | — | — | 0000 |
| | | 15:0 | — | — | — | — | — | — | — | — | — | — | — | — | IC6R<3:0> | | | 0000 |
| 1450 | IC7R | 31:16 | — | — | — | — | — | — | — | — | — | — | — | — | — | — | — | 0000 |
| | | 15:0 | — | — | — | — | — | — | — | — | — | — | — | — | IC7R<3:0> | | | 0000 |
| 1454 | IC8R | 31:16 | — | — | — | — | — | — | — | — | — | — | — | — | — | — | — | 0000 |
| | | 15:0 | — | — | — | — | — | — | — | — | — | — | — | — | IC8R<3:0> | | | 0000 |
| 1458 | IC9R | 31:16 | — | — | — | — | — | — | — | — | — | — | — | — | — | — | — | 0000 |
| | | 15:0 | — | — | — | — | — | — | — | — | — | — | — | — | IC9R<3:0> | | | 0000 |
| 1460 | OCFAR | 31:16 | — | — | — | — | — | — | — | — | — | — | — | — | — | — | — | 0000 |
| | | 15:0 | — | — | — | — | — | — | — | — | — | — | — | — | OCFAR<3:0> | | | 0000 |
| 1468 | U1RXR | 31:16 | — | — | — | — | — | — | — | — | — | — | — | — | — | — | — | 0000 |
| | | 15:0 | — | — | — | — | — | — | — | — | — | — | — | — | U1RXR<3:0> | | | 0000 |
| 146C | U1CTSR | 31:16 | — | — | — | — | — | — | — | — | — | — | — | — | — | — | — | 0000 |
| | | 15:0 | — | — | — | — | — | — | — | — | — | — | — | — | U1CTSR<3:0> | | | 0000 |
| 1470 | U2RXR | 31:16 | — | — | — | — | — | — | — | — | — | — | — | — | — | — | — | 0000 |
| | | 15:0 | — | — | — | — | — | — | — | — | — | — | — | — | U2RXR<3:0> | | | 0000 |
| 1474 | U2CTSR | 31:16 | — | — | — | — | — | — | — | — | — | — | — | — | — | — | — | 0000 |
| | | 15:0 | — | — | — | — | — | — | — | — | — | — | — | — | U2CTSR<3:0> | | | 0000 |
| 1478 | U3RXR | 31:16 | — | — | — | — | — | — | — | — | — | — | — | — | — | — | — | 0000 |
| | | 15:0 | — | — | — | — | — | — | — | — | — | — | — | — | U3RXR<3:0> | | | 0000 |
| 147C | U3CTSR | 31:16 | — | — | — | — | — | — | — | — | — | — | — | — | — | — | — | 0000 |
| | | 15:0 | — | — | — | — | — | — | — | — | — | — | — | — | U3CTSR<3:0> | | | 0000 |
| 1480 | U4RXR | 31:16 | — | — | — | — | — | — | — | — | — | — | — | — | — | — | — | 0000 |
| | | 15:0 | — | — | — | — | — | — | — | — | — | — | — | — | U4RXR<3:0> | | | 0000 |
| 1484 | U4CTSR | 31:16 | — | — | — | — | — | — | — | — | — | — | — | — | — | — | — | 0000 |
| | | 15:0 | — | — | — | — | — | — | — | — | — | — | — | — | U4CTSR<3:0> | | | 0000 |

Legend: x = unknown value on Reset; — = unimplemented, read as '0'. Reset values are shown in hexadecimal.

- Note** 1: This register is not available on 64-pin devices.
 2: This register is not available on devices without a CAN module.

TABLE 12-22: PERIPHERAL PIN SELECT INPUT REGISTER MAP (CONTINUED)

| Virtual Address (BF80_#) | Register Name | Bit Range | Bits | | | | | | | | | | | | | | | All Resets |
|-----------------------------|----------------------|-----------|-------|-------|-------|-------|-------|-------|------|------|------|------|------|------|-------------|------|------|------------|
| | | | 31/15 | 30/14 | 29/13 | 28/12 | 27/11 | 26/10 | 25/9 | 24/8 | 23/7 | 22/6 | 21/5 | 20/4 | 19/3 | 18/2 | 17/1 | |
| 1488 | U5RXR | 31:16 | — | — | — | — | — | — | — | — | — | — | — | — | — | — | — | 0000 |
| | | 15:0 | — | — | — | — | — | — | — | — | — | — | — | — | U5RXR<3:0> | | | 0000 |
| 148C | U5CTSR | 31:16 | — | — | — | — | — | — | — | — | — | — | — | — | — | — | — | 0000 |
| | | 15:0 | — | — | — | — | — | — | — | — | — | — | — | — | U5CTSR<3:0> | | | 0000 |
| 1490 | U6RXR | 31:16 | — | — | — | — | — | — | — | — | — | — | — | — | — | — | — | 0000 |
| | | 15:0 | — | — | — | — | — | — | — | — | — | — | — | — | U6RXR<3:0> | | | 0000 |
| 1494 | U6CTSR | 31:16 | — | — | — | — | — | — | — | — | — | — | — | — | — | — | — | 0000 |
| | | 15:0 | — | — | — | — | — | — | — | — | — | — | — | — | U6CTSR<3:0> | | | 0000 |
| 149C | SDI1R | 31:16 | — | — | — | — | — | — | — | — | — | — | — | — | — | — | — | 0000 |
| | | 15:0 | — | — | — | — | — | — | — | — | — | — | — | — | SDI1R<3:0> | | | 0000 |
| 14A0 | SS1R | 31:16 | — | — | — | — | — | — | — | — | — | — | — | — | — | — | — | 0000 |
| | | 15:0 | — | — | — | — | — | — | — | — | — | — | — | — | SS1R<3:0> | | | 0000 |
| 14A8 | SDI2R | 31:16 | — | — | — | — | — | — | — | — | — | — | — | — | — | — | — | 0000 |
| | | 15:0 | — | — | — | — | — | — | — | — | — | — | — | — | SDI2R<3:0> | | | 0000 |
| 14AC | SS2R | 31:16 | — | — | — | — | — | — | — | — | — | — | — | — | — | — | — | 0000 |
| | | 15:0 | — | — | — | — | — | — | — | — | — | — | — | — | SS2R<3:0> | | | 0000 |
| 14B4 | SDI3R | 31:16 | — | — | — | — | — | — | — | — | — | — | — | — | — | — | — | 0000 |
| | | 15:0 | — | — | — | — | — | — | — | — | — | — | — | — | SDI3R<3:0> | | | 0000 |
| 14B8 | SS3R | 31:16 | — | — | — | — | — | — | — | — | — | — | — | — | — | — | — | 0000 |
| | | 15:0 | — | — | — | — | — | — | — | — | — | — | — | — | SS3R<3:0> | | | 0000 |
| 14C0 | SDI4R | 31:16 | — | — | — | — | — | — | — | — | — | — | — | — | — | — | — | 0000 |
| | | 15:0 | — | — | — | — | — | — | — | — | — | — | — | — | SDI4R<3:0> | | | 0000 |
| 14C4 | SS4R | 31:16 | — | — | — | — | — | — | — | — | — | — | — | — | — | — | — | 0000 |
| | | 15:0 | — | — | — | — | — | — | — | — | — | — | — | — | SS4R<3:0> | | | 0000 |
| 14CC | SDI5R ⁽¹⁾ | 31:16 | — | — | — | — | — | — | — | — | — | — | — | — | — | — | — | 0000 |
| | | 15:0 | — | — | — | — | — | — | — | — | — | — | — | — | SDI5R<3:0> | | | 0000 |
| 14D0 | SS5R ⁽¹⁾ | 31:16 | — | — | — | — | — | — | — | — | — | — | — | — | — | — | — | 0000 |
| | | 15:0 | — | — | — | — | — | — | — | — | — | — | — | — | SS5R<3:0> | | | 0000 |
| 14D8 | SDI6R ⁽¹⁾ | 31:16 | — | — | — | — | — | — | — | — | — | — | — | — | — | — | — | 0000 |
| | | 15:0 | — | — | — | — | — | — | — | — | — | — | — | — | SDI6R<3:0> | | | 0000 |

Legend: x = unknown value on Reset; — = unimplemented, read as '0'. Reset values are shown in hexadecimal.

- Note** 1: This register is not available on 64-pin devices.
 2: This register is not available on devices without a CAN module.

TABLE 12-22: PERIPHERAL PIN SELECT INPUT REGISTER MAP (CONTINUED)

| Virtual Address (BF80_#) | Register Name | Bit Range | Bits | | | | | | | | | | | | | | | All Resets |
|-----------------------------|----------------------|-----------|-------|-------|-------|-------|-------|-------|------|------|------|------|------|------|---------------|------|------|------------|
| | | | 31/15 | 30/14 | 29/13 | 28/12 | 27/11 | 26/10 | 25/9 | 24/8 | 23/7 | 22/6 | 21/5 | 20/4 | 19/3 | 18/2 | 17/1 | |
| 14DC | SS6R ⁽¹⁾ | 31:16 | — | — | — | — | — | — | — | — | — | — | — | — | — | — | — | 0000 |
| | | 15:0 | — | — | — | — | — | — | — | — | — | — | — | — | SS6R<3:0> | | | 0000 |
| 14E0 | C1RXR ⁽²⁾ | 31:16 | — | — | — | — | — | — | — | — | — | — | — | — | — | — | — | 0000 |
| | | 15:0 | — | — | — | — | — | — | — | — | — | — | — | — | C1RXR<3:0> | | | 0000 |
| 14E4 | C2RXR ⁽²⁾ | 31:16 | — | — | — | — | — | — | — | — | — | — | — | — | — | — | — | 0000 |
| | | 15:0 | — | — | — | — | — | — | — | — | — | — | — | — | C2RXR<3:0> | | | 0000 |
| 14E8 | REFCLK1R | 31:16 | — | — | — | — | — | — | — | — | — | — | — | — | — | — | — | 0000 |
| | | 15:0 | — | — | — | — | — | — | — | — | — | — | — | — | REFCLK1R<3:0> | | | 0000 |
| 14F0 | REFCLK3R | 31:16 | — | — | — | — | — | — | — | — | — | — | — | — | — | — | — | 0000 |
| | | 15:0 | — | — | — | — | — | — | — | — | — | — | — | — | REFCLK3R<3:0> | | | 0000 |
| 14F4 | REFCLK4R | 31:16 | — | — | — | — | — | — | — | — | — | — | — | — | — | — | — | 0000 |
| | | 15:0 | — | — | — | — | — | — | — | — | — | — | — | — | REFCLK4R<3:0> | | | 0000 |

Legend: x = unknown value on Reset; — = unimplemented, read as '0'. Reset values are shown in hexadecimal.

- Note** 1: This register is not available on 64-pin devices.
 2: This register is not available on devices without a CAN module.

TABLE 12-23: PERIPHERAL PIN SELECT OUTPUT REGISTER MAP

| Virtual Address (BF60_#) | Register Name | Bit Range | Bits | | | | | | | | | | | | | | All Resets | | |
|-----------------------------|-----------------------|-----------|-------|-------|-------|-------|-------|-------|------|------|------|------|------|------|------|-------------|------------|------|------|
| | | | 31/15 | 30/14 | 29/13 | 28/12 | 27/11 | 26/10 | 25/9 | 24/8 | 23/7 | 22/6 | 21/5 | 20/4 | 19/3 | 18/2 | | 17/1 | 16/0 |
| 1538 | RPA14R ⁽¹⁾ | 31:16 | — | — | — | — | — | — | — | — | — | — | — | — | — | — | — | — | 0000 |
| | | 15:0 | — | — | — | — | — | — | — | — | — | — | — | — | — | RPA14R<3:0> | | | 0000 |
| 153C | RPA15R ⁽¹⁾ | 31:16 | — | — | — | — | — | — | — | — | — | — | — | — | — | — | — | — | 0000 |
| | | 15:0 | — | — | — | — | — | — | — | — | — | — | — | — | — | RPA15R<3:0> | | | 0000 |
| 1540 | RPB0R | 31:16 | — | — | — | — | — | — | — | — | — | — | — | — | — | — | — | — | 0000 |
| | | 15:0 | — | — | — | — | — | — | — | — | — | — | — | — | — | RPB0R<3:0> | | | 0000 |
| 1544 | RPB1R | 31:16 | — | — | — | — | — | — | — | — | — | — | — | — | — | — | — | — | 0000 |
| | | 15:0 | — | — | — | — | — | — | — | — | — | — | — | — | — | RPB1R<3:0> | | | 0000 |
| 1548 | RPB2R | 31:16 | — | — | — | — | — | — | — | — | — | — | — | — | — | — | — | — | 0000 |
| | | 15:0 | — | — | — | — | — | — | — | — | — | — | — | — | — | RPB2R<3:0> | | | 0000 |
| 154C | RPB3R | 31:16 | — | — | — | — | — | — | — | — | — | — | — | — | — | — | — | — | 0000 |
| | | 15:0 | — | — | — | — | — | — | — | — | — | — | — | — | — | RPB3R<3:0> | | | 0000 |
| 1554 | RPB5R | 31:16 | — | — | — | — | — | — | — | — | — | — | — | — | — | — | — | — | 0000 |
| | | 15:0 | — | — | — | — | — | — | — | — | — | — | — | — | — | RPB5R<3:0> | | | 0000 |
| 1558 | RPB6R | 31:16 | — | — | — | — | — | — | — | — | — | — | — | — | — | — | — | — | 0000 |
| | | 15:0 | — | — | — | — | — | — | — | — | — | — | — | — | — | RPB6R<3:0> | | | 0000 |
| 155C | RPB7R | 31:16 | — | — | — | — | — | — | — | — | — | — | — | — | — | — | — | — | 0000 |
| | | 15:0 | — | — | — | — | — | — | — | — | — | — | — | — | — | RPB7R<3:0> | | | 0000 |
| 1560 | RPB8R | 31:16 | — | — | — | — | — | — | — | — | — | — | — | — | — | — | — | — | 0000 |
| | | 15:0 | — | — | — | — | — | — | — | — | — | — | — | — | — | RPB8R<3:0> | | | 0000 |
| 1564 | RPB9R | 31:16 | — | — | — | — | — | — | — | — | — | — | — | — | — | — | — | — | 0000 |
| | | 15:0 | — | — | — | — | — | — | — | — | — | — | — | — | — | RPB9R<3:0> | | | 0000 |
| 1568 | RPB10R | 31:16 | — | — | — | — | — | — | — | — | — | — | — | — | — | — | — | — | 0000 |
| | | 15:0 | — | — | — | — | — | — | — | — | — | — | — | — | — | RPB10R<3:0> | | | 0000 |
| 1578 | RPB14R | 31:16 | — | — | — | — | — | — | — | — | — | — | — | — | — | — | — | — | 0000 |
| | | 15:0 | — | — | — | — | — | — | — | — | — | — | — | — | — | RPB14R<3:0> | | | 0000 |
| 157C | RPB15R | 31:16 | — | — | — | — | — | — | — | — | — | — | — | — | — | — | — | — | 0000 |
| | | 15:0 | — | — | — | — | — | — | — | — | — | — | — | — | — | RPB15R<3:0> | | | 0000 |
| 1584 | RPC1R ⁽¹⁾ | 31:16 | — | — | — | — | — | — | — | — | — | — | — | — | — | — | — | — | 0000 |
| | | 15:0 | — | — | — | — | — | — | — | — | — | — | — | — | — | RPC1R<3:0> | | | 0000 |
| 1588 | RPC2R ⁽¹⁾ | 31:16 | — | — | — | — | — | — | — | — | — | — | — | — | — | — | — | — | 0000 |
| | | 15:0 | — | — | — | — | — | — | — | — | — | — | — | — | — | RPC2R<3:0> | | | 0000 |
| 158C | RPC3R ⁽¹⁾ | 31:16 | — | — | — | — | — | — | — | — | — | — | — | — | — | — | — | — | 0000 |
| | | 15:0 | — | — | — | — | — | — | — | — | — | — | — | — | — | RPC3R<3:0> | | | 0000 |
| 1590 | RPC4R ⁽¹⁾ | 31:16 | — | — | — | — | — | — | — | — | — | — | — | — | — | — | — | — | 0000 |
| | | 15:0 | — | — | — | — | — | — | — | — | — | — | — | — | — | RPC4R<3:0> | | | 0000 |

Legend: x = unknown value on Reset; — = unimplemented, read as '0'. Reset values are shown in hexadecimal.

- Note** 1: This register is not available on 64-pin devices.
 2: This register is not available on 64-pin and 100-pin devices.

TABLE 12-23: PERIPHERAL PIN SELECT OUTPUT REGISTER MAP (CONTINUED)

| Virtual Address (BF80_#) | Register Name | Bit Range | Bits | | | | | | | | | | | | | | All Resets | |
|-----------------------------|-----------------------|--------------|-------|-------|-------|-------|-------|-------|------|------|------|------|------|------|------|------|---------------|------|
| | | | 31/15 | 30/14 | 29/13 | 28/12 | 27/11 | 26/10 | 25/9 | 24/8 | 23/7 | 22/6 | 21/5 | 20/4 | 19/3 | 18/2 | | 17/1 |
| 15B4 | RPC13R | 31:16 | — | — | — | — | — | — | — | — | — | — | — | — | — | — | — | 0000 |
| | | 15:0 | — | — | — | — | — | — | — | — | — | — | — | — | — | — | — | 0000 |
| 15B8 | RPC14R | 31:16 | — | — | — | — | — | — | — | — | — | — | — | — | — | — | — | 0000 |
| | | 15:0 | — | — | — | — | — | — | — | — | — | — | — | — | — | — | — | 0000 |
| 15C0 | RPD0R | 31:16 | — | — | — | — | — | — | — | — | — | — | — | — | — | — | — | 0000 |
| | | 15:0 | — | — | — | — | — | — | — | — | — | — | — | — | — | — | — | 0000 |
| 15C4 | RPD1R | 31:16 | — | — | — | — | — | — | — | — | — | — | — | — | — | — | — | 0000 |
| | | 15:0 | — | — | — | — | — | — | — | — | — | — | — | — | — | — | — | 0000 |
| 15C8 | RPD2R | 31:16 | — | — | — | — | — | — | — | — | — | — | — | — | — | — | — | 0000 |
| | | 15:0 | — | — | — | — | — | — | — | — | — | — | — | — | — | — | — | 0000 |
| 15CC | RPD3R | 31:16 | — | — | — | — | — | — | — | — | — | — | — | — | — | — | — | 0000 |
| | | 15:0 | — | — | — | — | — | — | — | — | — | — | — | — | — | — | — | 0000 |
| 15D0 | RPD4R | 31:16 | — | — | — | — | — | — | — | — | — | — | — | — | — | — | — | 0000 |
| | | 15:0 | — | — | — | — | — | — | — | — | — | — | — | — | — | — | — | 0000 |
| 15D4 | RPD5R | 31:16 | — | — | — | — | — | — | — | — | — | — | — | — | — | — | — | 0000 |
| | | 15:0 | — | — | — | — | — | — | — | — | — | — | — | — | — | — | — | 0000 |
| 15D8 | RPD6R ⁽²⁾ | 31:16 | — | — | — | — | — | — | — | — | — | — | — | — | — | — | — | 0000 |
| | | 15:0 | — | — | — | — | — | — | — | — | — | — | — | — | — | — | — | 0000 |
| 15DC | RPD7R ⁽²⁾ | 31:16 | — | — | — | — | — | — | — | — | — | — | — | — | — | — | — | 0000 |
| | | 15:0 | — | — | — | — | — | — | — | — | — | — | — | — | — | — | — | 0000 |
| 15E4 | RPD9R | 31:16 | — | — | — | — | — | — | — | — | — | — | — | — | — | — | — | 0000 |
| | | 15:0 | — | — | — | — | — | — | — | — | — | — | — | — | — | — | — | 0000 |
| 15E8 | RPD10R | 31:16 | — | — | — | — | — | — | — | — | — | — | — | — | — | — | — | 0000 |
| | | 15:0 | — | — | — | — | — | — | — | — | — | — | — | — | — | — | — | 0000 |
| 15EC | RPD11R | 31:16 | — | — | — | — | — | — | — | — | — | — | — | — | — | — | — | 0000 |
| | | 15:0 | — | — | — | — | — | — | — | — | — | — | — | — | — | — | — | 0000 |
| 15F0 | RPD12R ⁽¹⁾ | 31:16 | — | — | — | — | — | — | — | — | — | — | — | — | — | — | — | 0000 |
| | | 15:0 | — | — | — | — | — | — | — | — | — | — | — | — | — | — | — | 0000 |
| 15F8 | RPD14R ⁽¹⁾ | 31:16 | — | — | — | — | — | — | — | — | — | — | — | — | — | — | — | 0000 |
| | | 15:0 | — | — | — | — | — | — | — | — | — | — | — | — | — | — | — | 0000 |
| 15FC | RPD15R ⁽¹⁾ | 31:16 | — | — | — | — | — | — | — | — | — | — | — | — | — | — | — | 0000 |
| | | 15:0 | — | — | — | — | — | — | — | — | — | — | — | — | — | — | — | 0000 |
| 160C | RPE3R | 31:16 | — | — | — | — | — | — | — | — | — | — | — | — | — | — | — | 0000 |
| | | 15:0 | — | — | — | — | — | — | — | — | — | — | — | — | — | — | — | 0000 |
| 1614 | RPE5R | 31:16 | — | — | — | — | — | — | — | — | — | — | — | — | — | — | — | 0000 |
| | | 15:0 | — | — | — | — | — | — | — | — | — | — | — | — | — | — | — | 0000 |

Legend: x = unknown value on Reset; — = unimplemented, read as '0'. Reset values are shown in hexadecimal.

- Note** 1: This register is not available on 64-pin devices.
 2: This register is not available on 64-pin and 100-pin devices.

TABLE 12-23: PERIPHERAL PIN SELECT OUTPUT REGISTER MAP (CONTINUED)

| Virtual Address (BF80_#) | Register Name | Bit Range | Bits | | | | | | | | | | | | | | | | All Resets |
|-----------------------------|-----------------------|--------------|-------|-------|-------|-------|-------|-------|------|------|------|------|------|------|------|-------------|------|------|---------------|
| | | | 31/15 | 30/14 | 29/13 | 28/12 | 27/11 | 26/10 | 25/9 | 24/8 | 23/7 | 22/6 | 21/5 | 20/4 | 19/3 | 18/2 | 17/1 | 16/0 | |
| 1620 | RPE8R ⁽¹⁾ | 31:16 | — | — | — | — | — | — | — | — | — | — | — | — | — | — | — | — | 0000 |
| | | 15:0 | — | — | — | — | — | — | — | — | — | — | — | — | — | RPE8R<3:0> | | | 0000 |
| 1624 | RPE9R ⁽¹⁾ | 31:16 | — | — | — | — | — | — | — | — | — | — | — | — | — | — | — | — | 0000 |
| | | 15:0 | — | — | — | — | — | — | — | — | — | — | — | — | — | RPE9R<3:0> | | | 0000 |
| 1640 | RPF0R | 31:16 | — | — | — | — | — | — | — | — | — | — | — | — | — | — | — | — | 0000 |
| | | 15:0 | — | — | — | — | — | — | — | — | — | — | — | — | — | RPF0R<3:0> | | | 0000 |
| 1644 | RPF1R | 31:16 | — | — | — | — | — | — | — | — | — | — | — | — | — | — | — | — | 0000 |
| | | 15:0 | — | — | — | — | — | — | — | — | — | — | — | — | — | RPF1R<3:0> | | | 0000 |
| 1648 | RPF2R ⁽¹⁾ | 31:16 | — | — | — | — | — | — | — | — | — | — | — | — | — | — | — | — | 0000 |
| | | 15:0 | — | — | — | — | — | — | — | — | — | — | — | — | — | RPF2R<3:0> | | | 0000 |
| 164C | RPF3R | 31:16 | — | — | — | — | — | — | — | — | — | — | — | — | — | — | — | — | 0000 |
| | | 15:0 | — | — | — | — | — | — | — | — | — | — | — | — | — | RPF3R<3:0> | | | 0000 |
| 1650 | RPF4R | 31:16 | — | — | — | — | — | — | — | — | — | — | — | — | — | — | — | — | 0000 |
| | | 15:0 | — | — | — | — | — | — | — | — | — | — | — | — | — | RPF4R<3:0> | | | 0000 |
| 1654 | RPF5R | 31:16 | — | — | — | — | — | — | — | — | — | — | — | — | — | — | — | — | 0000 |
| | | 15:0 | — | — | — | — | — | — | — | — | — | — | — | — | — | RPF5R<3:0> | | | 0000 |
| 1660 | RPF8R ⁽¹⁾ | 31:16 | — | — | — | — | — | — | — | — | — | — | — | — | — | — | — | — | 0000 |
| | | 15:0 | — | — | — | — | — | — | — | — | — | — | — | — | — | RPF8R<3:0> | | | 0000 |
| 1670 | RPF12R ⁽¹⁾ | 31:16 | — | — | — | — | — | — | — | — | — | — | — | — | — | — | — | — | 0000 |
| | | 15:0 | — | — | — | — | — | — | — | — | — | — | — | — | — | RPG12R<3:0> | | | 0000 |
| 1674 | RPF13R ⁽¹⁾ | 31:16 | — | — | — | — | — | — | — | — | — | — | — | — | — | — | — | — | 0000 |
| | | 15:0 | — | — | — | — | — | — | — | — | — | — | — | — | — | RPG0R<3:0> | | | 0000 |
| 1680 | RPG0R ⁽¹⁾ | 31:16 | — | — | — | — | — | — | — | — | — | — | — | — | — | — | — | — | 0000 |
| | | 15:0 | — | — | — | — | — | — | — | — | — | — | — | — | — | RPG1R<3:0> | | | 0000 |
| 1684 | RPG1R ⁽¹⁾ | 31:16 | — | — | — | — | — | — | — | — | — | — | — | — | — | — | — | — | 0000 |
| | | 15:0 | — | — | — | — | — | — | — | — | — | — | — | — | — | RPG1R<3:0> | | | 0000 |
| 1698 | RPG6R | 31:16 | — | — | — | — | — | — | — | — | — | — | — | — | — | — | — | — | 0000 |
| | | 15:0 | — | — | — | — | — | — | — | — | — | — | — | — | — | RPG6R<3:0> | | | 0000 |
| 169C | RPG7R | 31:16 | — | — | — | — | — | — | — | — | — | — | — | — | — | — | — | — | 0000 |
| | | 15:0 | — | — | — | — | — | — | — | — | — | — | — | — | — | RPG7R<3:0> | | | 0000 |
| 16A0 | RPG8R | 31:16 | — | — | — | — | — | — | — | — | — | — | — | — | — | — | — | — | 0000 |
| | | 15:0 | — | — | — | — | — | — | — | — | — | — | — | — | — | RPG8R<3:0> | | | 0000 |
| 16A4 | RPG9R | 31:16 | — | — | — | — | — | — | — | — | — | — | — | — | — | — | — | — | 0000 |
| | | 15:0 | — | — | — | — | — | — | — | — | — | — | — | — | — | RPG9R<3:0> | | | 0000 |

Legend: x = unknown value on Reset; — = unimplemented, read as '0'. Reset values are shown in hexadecimal.

- Note** 1: This register is not available on 64-pin devices.
 2: This register is not available on 64-pin and 100-pin devices.

PIC32MZ Embedded Connectivity with Floating Point Unit (EF) Family

REGISTER 12-3: CNCONx: CHANGE NOTICE CONTROL FOR PORTx REGISTER (x = A – K)

| Bit Range | Bit 31/23/15/7 | Bit 30/22/14/6 | Bit 29/21/13/5 | Bit 28/20/12/4 | Bit 27/19/11/3 | Bit 26/18/10/2 | Bit 25/17/9/1 | Bit 24/16/8/0 |
|-----------|----------------|----------------|----------------|----------------|----------------|----------------|---------------|---------------|
| 31:24 | U-0 | U-0 | U-0 | U-0 | U-0 | U-0 | U-0 | U-0 |
| | — | — | — | — | — | — | — | — |
| 23:16 | U-0 | U-0 | U-0 | U-0 | U-0 | U-0 | U-0 | U-0 |
| | — | — | — | — | — | — | — | — |
| 15:8 | R/W-0 | U-0 | R/W-0 | U-0 | R/W-0 | U-0 | U-0 | U-0 |
| | ON | — | SIDL | — | EDGEDETECT | — | — | — |
| 7:0 | U-0 | U-0 | U-0 | U-0 | U-0 | U-0 | U-0 | U-0 |
| | — | — | — | — | — | — | — | — |

Legend:

| | | |
|-------------------|------------------|------------------------------------|
| R = Readable bit | W = Writable bit | U = Unimplemented bit, read as '0' |
| -n = Value at POR | '1' = Bit is set | '0' = Bit is cleared |
| | | x = Bit is unknown |

bit 31-16 **Unimplemented:** Read as '0'

bit 15 **ON:** Change Notice (CN) Control ON bit

- 1 = CN is enabled
- 0 = CN is disabled

bit 14 **Unimplemented:** Read as '0'

bit 13 **SIDL:** Stop in Idle Control bit

- 1 = CPU Idle mode halts CN operation
- 0 = CPU Idle mode does not affect CN operation

bit 12 **Unimplemented:** Read as '0'

bit 11 **EDGEDETECT:** Change Notification Style bit

- 1 = Edge Style. Detect edge transitions (CNFx used for CN Event).
- 0 = Mismatch Style. Detect change from last PORTx read (CNSTATx used for CN Event).

bit 10-0 **Unimplemented:** Read as '0'

13.0 TIMER1

Note: This data sheet summarizes the features of the PIC32MZ EF family of devices. It is not intended to be a comprehensive reference source. To complement the information in this data sheet, refer to **Section 14. “Timers”** (DS60001105) in the *“PIC32 Family Reference Manual”*, which is available from the Microchip web site (www.microchip.com/PIC32).

PIC32MZ EF devices feature one synchronous/asynchronous 16-bit timer that can operate as a free-running interval timer for various timing applications and counting external events. This timer can also be used with the Low-Power Secondary Oscillator (SOSC) for real-time clock applications.

The following modes are supported by Timer1:

- Synchronous Internal Timer
- Synchronous Internal Gated Timer
- Synchronous External Timer
- Asynchronous External Timer

13.1 Additional Supported Features

- Selectable clock prescaler
- Timer operation during Sleep and Idle modes
- Fast bit manipulation using CLR, SET and INV registers
- Asynchronous mode can be used with the SOSC to function as a real-time clock
- ADC event trigger

FIGURE 13-1: TIMER1 BLOCK DIAGRAM

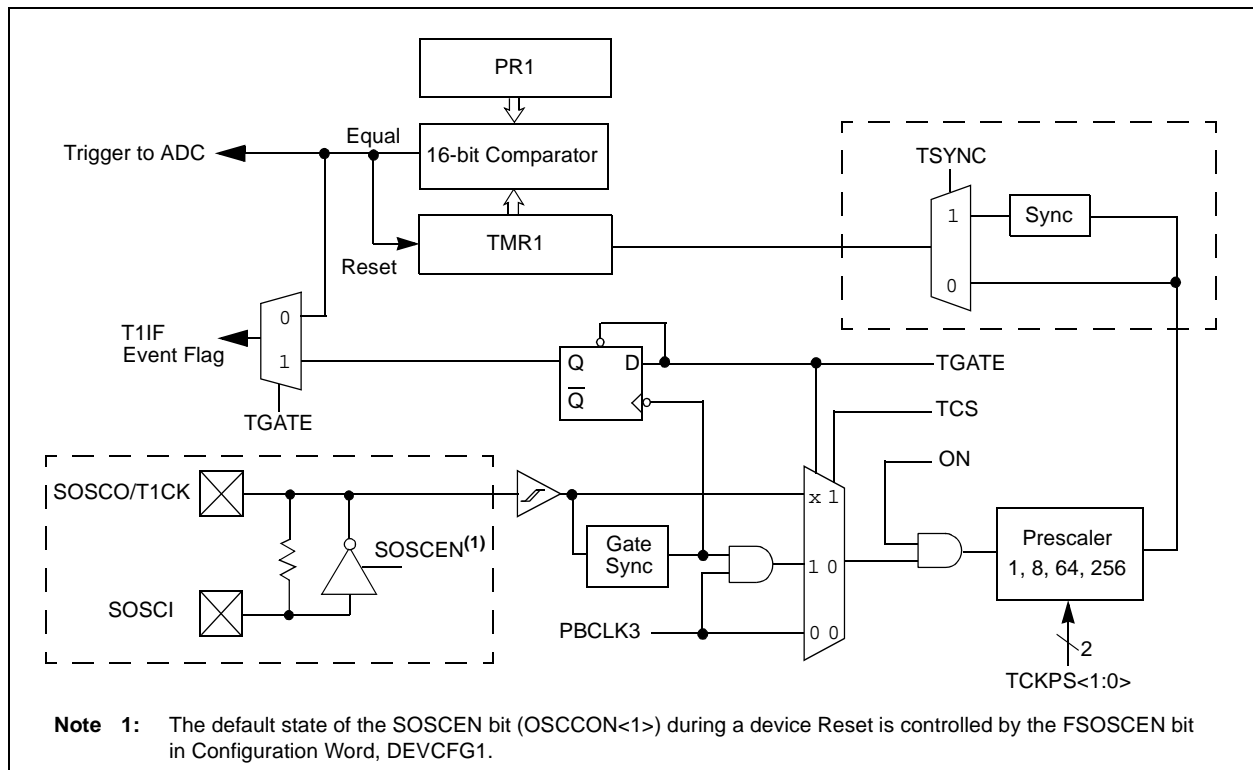

13.2 Timer1 Control Register

TABLE 13-1: TIMER1 REGISTER MAP

| Virtual Address (BF84_#) | Register Name(s) | Bit Range | Bits | | | | | | | | | | | | | | | All Resets | |
|-----------------------------|---------------------|-----------|------------|-------|-------|-------|-------|-------|------|------|-------|------|------------|------|------|------|-------|------------|------|
| | | | 31/15 | 30/14 | 29/13 | 28/12 | 27/11 | 26/10 | 25/9 | 24/8 | 23/7 | 22/6 | 21/5 | 20/4 | 19/3 | 18/2 | 17/1 | | 16/0 |
| 0000 | T1CON | 31:16 | — | — | — | — | — | — | — | — | — | — | — | — | — | — | — | — | 0000 |
| | | 15:0 | ON | — | SIDL | TWDIS | TWIP | — | — | — | TGATE | — | TCKPS<1:0> | | | — | TSYNC | TCS | — |
| 0010 | TMR1 | 31:16 | — | — | — | — | — | — | — | — | — | — | — | — | — | — | — | — | 0000 |
| | | 15:0 | TMR1<15:0> | | | | | | | | | | | | | | | 0000 | |
| 0020 | PR1 | 31:16 | — | — | — | — | — | — | — | — | — | — | — | — | — | — | — | — | 0000 |
| | | 15:0 | PR1<15:0> | | | | | | | | | | | | | | | FFFF | |

Legend: x = unknown value on Reset; — = unimplemented, read as '0'. Reset values are shown in hexadecimal.

Note 1: All registers in this table have corresponding CLR, SET and INV registers at their virtual addresses, plus offsets of 0x4, 0x8 and 0xC, respectively. See [Section 12.3 "CLR, SET, and INV Registers"](#) for more information.

PIC32MZ Embedded Connectivity with Floating Point Unit (EF) Family

REGISTER 13-1: T1CON: TYPE A TIMER CONTROL REGISTER (CONTINUED)

bit 2 **TSYNC:** Timer External Clock Input Synchronization Selection bit

When TCS = 1:

1 = External clock input is synchronized

0 = External clock input is not synchronized

When TCS = 0:

This bit is ignored.

bit 1 **TCS:** Timer Clock Source Select bit

1 = External clock from T1CKI pin

0 = Internal peripheral clock

bit 0 **Unimplemented:** Read as '0'

14.0 TIMER2/3, TIMER4/5, TIMER6/7, AND TIMER8/9

Note: This data sheet summarizes the features of the PIC32MZ EF family of devices. It is not intended to be a comprehensive reference source. To complement the information in this data sheet, refer to **Section 14. “Timers”** (DS60001105) of the “PIC32 Family Reference Manual”, which is available from the Microchip web site (www.microchip.com/PIC32).

This family of devices features eight synchronous 16-bit timers (default) that can operate as a free-running interval timer for various timing applications and counting external events.

The following modes are supported:

- Synchronous internal 16-bit timer
- Synchronous internal 16-bit gated timer
- Synchronous external 16-bit timer

Four 32-bit synchronous timers are available by combining Timer2 with Timer3, Timer4 with Timer5, Timer6 with Timer7, and Timer8 with Timer9.

The 32-bit timers can operate in one of three modes:

- Synchronous internal 32-bit timer
- Synchronous internal 32-bit gated timer
- Synchronous external 32-bit timer

14.1 Additional Supported Features

- Selectable clock prescaler
- Timers operational during CPU idle
- Time base for Input Capture and Output Compare modules (Timer2 through Timer7 only)
- ADC event trigger (Timer3 and Timer5 only)
- Fast bit manipulation using CLR, SET, and INV registers

FIGURE 14-1: TIMER2 THROUGH TIMER9 BLOCK DIAGRAM (16-BIT)

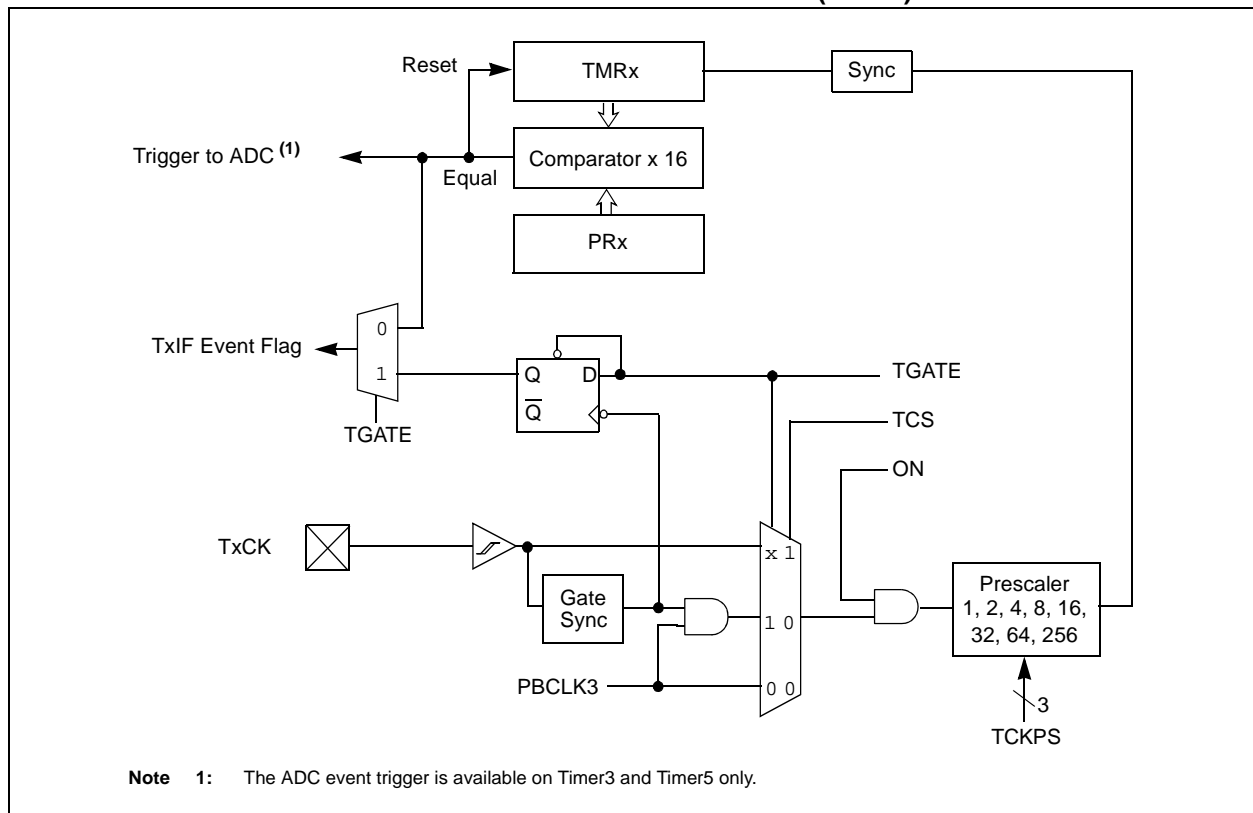

PIC32MZ Embedded Connectivity with Floating Point Unit (EF) Family

FIGURE 14-2: TIMER2/3, TIMER4/5, TIMER6/7, AND TIMER8/9 BLOCK DIAGRAM (32-BIT)

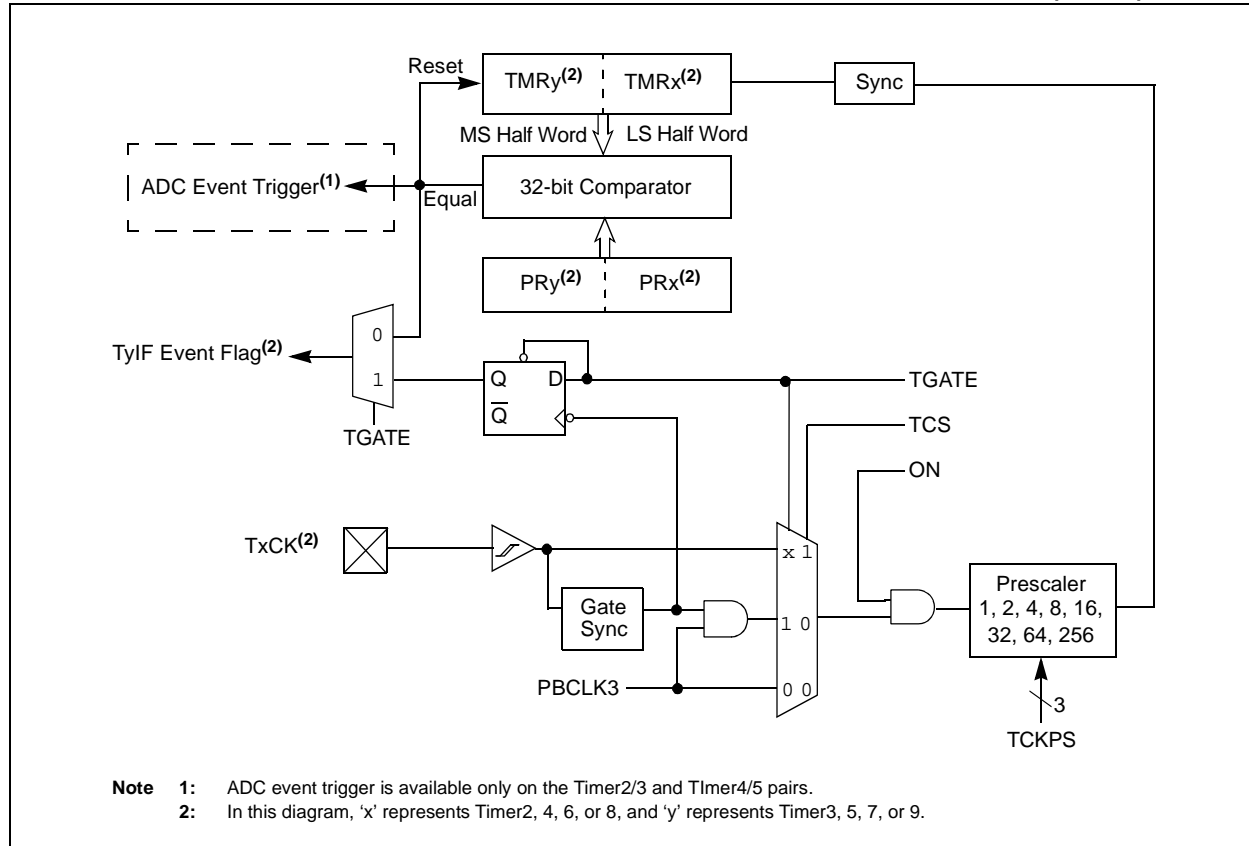

14.2 Timer2-Timer9 Control Registers

TABLE 14-1: TIMER2 THROUGH TIMER9 REGISTER MAP

| Virtual Address (BF84_#) | Register Name(s) | Bit Range | Bits | | | | | | | | | | | | | | | | All Resets |
|-----------------------------|---------------------|-----------|------------|-------|-------|-------|-------|-------|------|------|-------|------------|------|------|------|------|------|------|------------|
| | | | 31/15 | 30/14 | 29/13 | 28/12 | 27/11 | 26/10 | 25/9 | 24/8 | 23/7 | 22/6 | 21/5 | 20/4 | 19/3 | 18/2 | 17/1 | 16/0 | |
| 0200 | T2CON | 31:16 | — | — | — | — | — | — | — | — | — | — | — | — | — | — | — | — | 0000 |
| | | 15:0 | ON | — | SIDL | — | — | — | — | — | TGATE | TCKPS<2:0> | | | — | T32 | — | TCS | — |
| 0210 | TMR2 | 31:16 | — | — | — | — | — | — | — | — | — | — | — | — | — | — | — | — | 0000 |
| | | 15:0 | TMR2<15:0> | | | | | | | | | | | | | | | | 0000 |
| 0220 | PR2 | 31:16 | — | — | — | — | — | — | — | — | — | — | — | — | — | — | — | — | 0000 |
| | | 15:0 | PR2<15:0> | | | | | | | | | | | | | | | | FFFF |
| 0400 | T3CON | 31:16 | — | — | — | — | — | — | — | — | — | — | — | — | — | — | — | — | 0000 |
| | | 15:0 | ON | — | SIDL | — | — | — | — | — | TGATE | TCKPS<2:0> | | | — | — | TCS | — | 0000 |
| 0410 | TMR3 | 31:16 | — | — | — | — | — | — | — | — | — | — | — | — | — | — | — | — | 0000 |
| | | 15:0 | TMR3<15:0> | | | | | | | | | | | | | | | | 0000 |
| 0420 | PR3 | 31:16 | — | — | — | — | — | — | — | — | — | — | — | — | — | — | — | — | 0000 |
| | | 15:0 | PR3<15:0> | | | | | | | | | | | | | | | | FFFF |
| 0600 | T4CON | 31:16 | — | — | — | — | — | — | — | — | — | — | — | — | — | — | — | — | 0000 |
| | | 15:0 | ON | — | SIDL | — | — | — | — | — | TGATE | TCKPS<2:0> | | | — | T32 | — | TCS | — |
| 0610 | TMR4 | 31:16 | — | — | — | — | — | — | — | — | — | — | — | — | — | — | — | — | 0000 |
| | | 15:0 | TMR4<15:0> | | | | | | | | | | | | | | | | 0000 |
| 0620 | PR4 | 31:16 | — | — | — | — | — | — | — | — | — | — | — | — | — | — | — | — | 0000 |
| | | 15:0 | PR4<15:0> | | | | | | | | | | | | | | | | FFFF |
| 0800 | T5CON | 31:16 | — | — | — | — | — | — | — | — | — | — | — | — | — | — | — | — | 0000 |
| | | 15:0 | ON | — | SIDL | — | — | — | — | — | TGATE | TCKPS<2:0> | | | — | — | TCS | — | 0000 |
| 0810 | TMR5 | 31:16 | — | — | — | — | — | — | — | — | — | — | — | — | — | — | — | — | 0000 |
| | | 15:0 | TMR5<15:0> | | | | | | | | | | | | | | | | 0000 |
| 0820 | PR5 | 31:16 | — | — | — | — | — | — | — | — | — | — | — | — | — | — | — | — | 0000 |
| | | 15:0 | PR5<15:0> | | | | | | | | | | | | | | | | FFFF |
| 0A00 | T6CON | 31:16 | — | — | — | — | — | — | — | — | — | — | — | — | — | — | — | — | 0000 |
| | | 15:0 | ON | — | SIDL | — | — | — | — | — | TGATE | TCKPS<2:0> | | | — | T32 | — | TCS | — |
| 0A10 | TMR6 | 31:16 | — | — | — | — | — | — | — | — | — | — | — | — | — | — | — | — | 0000 |
| | | 15:0 | TMR6<15:0> | | | | | | | | | | | | | | | | 0000 |
| 0A20 | PR6 | 31:16 | — | — | — | — | — | — | — | — | — | — | — | — | — | — | — | — | 0000 |
| | | 15:0 | PR6<15:0> | | | | | | | | | | | | | | | | FFFF |
| 0C00 | T7CON | 31:16 | — | — | — | — | — | — | — | — | — | — | — | — | — | — | — | — | 0000 |
| | | 15:0 | ON | — | SIDL | — | — | — | — | — | TGATE | TCKPS<2:0> | | | — | — | TCS | — | 0000 |

Legend: x = unknown value on Reset; — = unimplemented, read as '0'. Reset values are shown in hexadecimal.

Note 1: All registers in this table have corresponding CLR, SET and INV registers at their virtual addresses, plus offsets of 0x4, 0x8 and 0xC, respectively. See [Section 12.3 “CLR, SET, and INV Registers”](#) for more information.

TABLE 14-1: TIMER2 THROUGH TIMER9 REGISTER MAP (CONTINUED)

| Virtual Address (BF94.#) | Register Name(1) | Bit Range | Bits | | | | | | | | | | | | | | | All Resets | |
|-----------------------------|---------------------|-----------|------------|-------|-------|-------|-------|-------|------|------|-------|------------|------------|------|------|------|------|------------|------|
| | | | 31/15 | 30/14 | 29/13 | 28/12 | 27/11 | 26/10 | 25/9 | 24/8 | 23/7 | 22/6 | 21/5 | 20/4 | 19/3 | 18/2 | 17/1 | | 16/0 |
| 0C10 | TMR7 | 31:16 | — | — | — | — | — | — | — | — | — | — | — | — | — | — | — | — | 0000 |
| | | 15:0 | TMR7<15:0> | | | | | | | | | | | | | | | 0000 | |
| 0C20 | PR7 | 31:16 | — | — | — | — | — | — | — | — | — | — | — | — | — | — | — | — | 0000 |
| | | 15:0 | PR7<15:0> | | | | | | | | | | | | | | | FFFF | |
| 0E00 | T8CON | 31:16 | — | — | — | — | — | — | — | — | — | — | — | — | — | — | — | — | 0000 |
| | | 15:0 | ON | — | SIDL | — | — | — | — | — | TGATE | TCKPS<2:0> | | — | T32 | — | — | TCS | — |
| 0E10 | TMR8 | 31:16 | — | — | — | — | — | — | — | — | — | — | — | — | — | — | — | — | 0000 |
| | | 15:0 | TMR8<15:0> | | | | | | | | | | | | | | | 0000 | |
| 0E20 | PR8 | 31:16 | — | — | — | — | — | — | — | — | — | — | — | — | — | — | — | — | 0000 |
| | | 15:0 | PR8<15:0> | | | | | | | | | | | | | | | FFFF | |
| 1000 | T9CON | 31:16 | — | — | — | — | — | — | — | — | — | — | — | — | — | — | — | — | 0000 |
| | | 15:0 | ON | — | SIDL | — | — | — | — | — | — | TGATE | TCKPS<2:0> | | — | — | — | TCS | — |
| 1010 | TMR9 | 31:16 | — | — | — | — | — | — | — | — | — | — | — | — | — | — | — | — | 0000 |
| | | 15:0 | TMR9<15:0> | | | | | | | | | | | | | | | 0000 | |
| 1020 | PR9 | 31:16 | — | — | — | — | — | — | — | — | — | — | — | — | — | — | — | — | 0000 |
| | | 15:0 | PR9<15:0> | | | | | | | | | | | | | | | FFFF | |

Legend: x = unknown value on Reset; — = unimplemented, read as '0'. Reset values are shown in hexadecimal.

Note 1: All registers in this table have corresponding CLR, SET and INV registers at their virtual addresses, plus offsets of 0x4, 0x8 and 0xC, respectively. See [Section 12.3 “CLR, SET, and INV Registers”](#) for more information.

PIC32MZ Embedded Connectivity with Floating Point Unit (EF) Family

REGISTER 14-1: TxCON: TYPE B TIMER CONTROL REGISTER ('x' = 2-9) (CONTINUED)

- bit 2 **Unimplemented:** Read as '0'
- bit 1 **TCS:** Timer Clock Source Select bit⁽¹⁾
 1 = External clock from TxCK pin
 0 = Internal peripheral clock
- bit 0 **Unimplemented:** Read as '0'

- Note 1:** While operating in 32-bit mode, this bit has no effect for odd numbered timers (Timer1, Timer3, Timer5, Timer7, and Timer9). All timer functions are set through the even numbered timers.
- 2:** While operating in 32-bit mode, this bit must be cleared on odd numbered timers to enable the 32-bit timer in Idle mode.
- 3:** This bit is available only on even numbered timers (Timer2, Timer4, Timer6, and Timer8).

15.0 DEADMAN TIMER (DMT)

Note: This data sheet summarizes the features of the PIC32MZ EF family of devices. It is not intended to be a comprehensive reference source. To complement the information in this data sheet, refer to **Section 9. “Watchdog, Deadman, and Power-up Timers”** (DS60001114) in the *“PIC32 Family Reference Manual”*, which is available from the Microchip web site (www.microchip.com/PIC32).

The DMT consists of a 32-bit counter with a time-out count match value as specified by the DMTCNT<3:0> bits in the DEVCFG1 Configuration register.

A Deadman Timer is typically used in mission critical and safety critical applications, where any single failure of the software functionality and sequencing must be detected.

Figure 15-1 shows a block diagram of the Deadman Timer module.

The primary function of the Deadman Timer (DMT) is to reset the processor in the event of a software malfunction. The DMT is a free-running instruction fetch timer, which is clocked whenever an instruction fetch occurs until a count match occurs. Instructions are not fetched when the processor is in Sleep mode.

FIGURE 15-1: DEADMAN TIMER BLOCK DIAGRAM

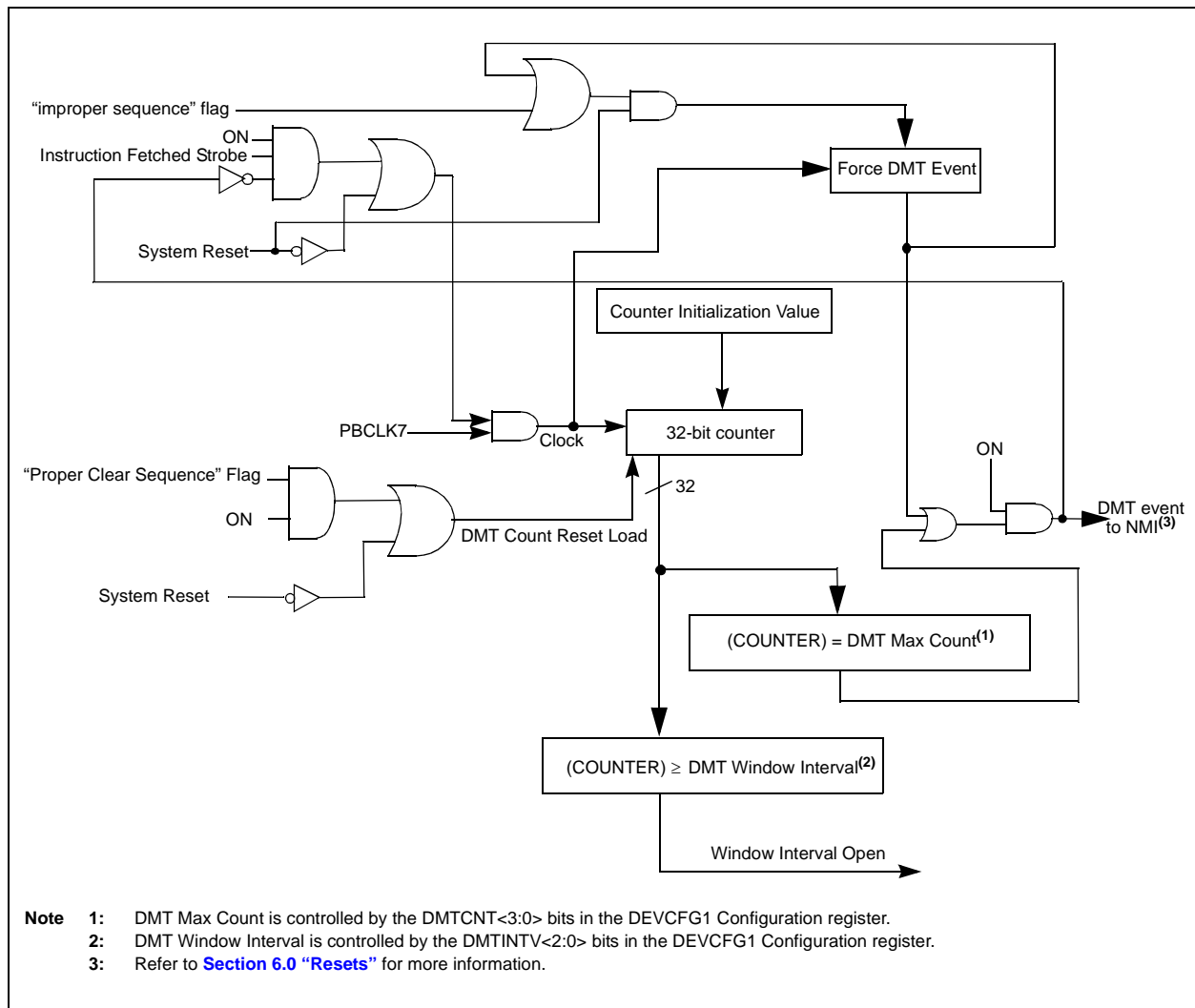

15.1 Deadman Timer Control Registers

TABLE 15-1: DEADMAN TIMER REGISTER MAP

| Virtual Address (BF80_#) | Register Name | Bit Range | Bits | | | | | | | | | | | | | | | | All Resets | |
|-----------------------------|---------------|-----------|---------------|-------|-------|-------|-------|-------|------|------|------------|------|----------|------|------|------|------|------|------------|------|
| | | | 31/15 | 30/14 | 29/13 | 28/12 | 27/11 | 26/10 | 25/9 | 24/8 | 23/7 | 22/6 | 21/5 | 20/4 | 19/3 | 18/2 | 17/1 | 16/0 | | |
| 0A00 | DMTCON | 31:16 | — | — | — | — | — | — | — | — | — | — | — | — | — | — | — | — | 0000 | |
| | | 15:0 | ON | — | — | — | — | — | — | — | — | — | — | — | — | — | — | — | x000 | |
| 0A10 | DMTPRECLR | 31:16 | — | — | — | — | — | — | — | — | — | — | — | — | — | — | — | — | 0000 | |
| | | 15:0 | STEP1<7:0> | | | | | | | | | — | — | — | — | — | — | — | 0000 | |
| 0A20 | DMTCLR | 31:16 | — | — | — | — | — | — | — | — | — | — | — | — | — | — | — | — | 0000 | |
| | | 15:0 | — | — | — | — | — | — | — | — | STEP2<7:0> | | | | | | | — | — | — |
| 0A30 | DMTSTAT | 31:16 | — | — | — | — | — | — | — | — | — | — | — | — | — | — | — | — | 0000 | |
| | | 15:0 | — | — | — | — | — | — | — | — | BAD1 | BAD2 | DMTEVENT | — | — | — | — | — | WINOPN | 0000 |
| 0A40 | DMTCNT | 31:16 | COUNTER<31:0> | | | | | | | | | | | | | | | | 0000 | |
| | | 15:0 | COUNTER<31:0> | | | | | | | | | | | | | | | | 0000 | |
| 0A60 | DMTPSCNT | 31:16 | PSCNT<31:0> | | | | | | | | | | | | | | | | 0000 | |
| | | 15:0 | PSCNT<31:0> | | | | | | | | | | | | | | | | 00xx | |
| 0A70 | DMTPSINTV | 31:16 | PSINTV<31:0> | | | | | | | | | | | | | | | | 0000 | |
| | | 15:0 | PSINTV<31:0> | | | | | | | | | | | | | | | | 000x | |

Legend: x = unknown value on Reset; — = unimplemented, read as '0'. Reset values are shown in hexadecimal.

PIC32MZ Embedded Connectivity with Floating Point Unit (EF) Family

REGISTER 15-1: DMTCON: DEADMAN TIMER CONTROL REGISTER

| Bit Range | Bit 31/23/15/7 | Bit 30/22/14/6 | Bit 29/21/13/5 | Bit 28/20/12/4 | Bit 27/19/11/3 | Bit 26/18/10/2 | Bit 25/17/9/1 | Bit 24/16/8/0 |
|-----------|-------------------|-------------------|-------------------|-------------------|-------------------|-------------------|------------------|------------------|
| 31:24 | U-0 | U-0 | U-0 | U-0 | U-0 | U-0 | U-0 | U-0 |
| | — | — | — | — | — | — | — | — |
| 23:16 | U-0 | U-0 | U-0 | U-0 | U-0 | U-0 | U-0 | U-0 |
| | — | — | — | — | — | — | — | — |
| 15:8 | R/W-y | U-0 | U-0 | U-0 | U-0 | U-0 | U-0 | U-0 |
| | ON ⁽¹⁾ | — | — | — | — | — | — | — |
| 7:0 | U-0 | U-0 | U-0 | U-0 | U-0 | U-0 | U-0 | U-0 |
| | — | — | — | — | — | — | — | — |

| | |
|-------------------|--|
| Legend: | y = Value set from Configuration bits on POR |
| R = Readable bit | W = Writable bit |
| -n = Value at POR | U = Unimplemented bit, read as '0' |
| | '1' = Bit is set |
| | '0' = Bit is cleared |
| | x = Bit is unknown |

bit 31-16 **Unimplemented:** Read as '0'

bit 15 **ON:** Deadman Timer Module Enable bit⁽¹⁾

1 = Deadman Timer module is enabled

0 = Deadman Timer module is disabled

The reset value of this bit is determined by the setting of the FDMTEN bit (DEVCFG1<3>).

bit 13-0 **Unimplemented:** Read as '0'

Note 1: This bit only has control when FDMTEN (DEVCFG1<3>) = 0.

REGISTER 15-2: DMTPRECLR: DEADMAN TIMER PRECLEAR REGISTER

| Bit Range | Bit 31/23/15/7 | Bit 30/22/14/6 | Bit 29/21/13/5 | Bit 28/20/12/4 | Bit 27/19/11/3 | Bit 26/18/10/2 | Bit 25/17/9/1 | Bit 24/16/8/0 |
|-----------|-------------------|-------------------|-------------------|-------------------|-------------------|-------------------|------------------|------------------|
| 31:24 | U-0 | U-0 | U-0 | U-0 | U-0 | U-0 | U-0 | U-0 |
| | — | — | — | — | — | — | — | — |
| 23:16 | U-0 | U-0 | U-0 | U-0 | U-0 | U-0 | U-0 | U-0 |
| | — | — | — | — | — | — | — | — |
| 15:8 | R/W-0 | R/W-0 | R/W-0 | R/W-0 | R/W-0 | R/W-0 | R/W-0 | R/W-0 |
| | STEP1<7:0> | | | | | | | |
| 7:0 | U-0 | U-0 | U-0 | U-0 | U-0 | U-0 | U-0 | U-0 |
| | — | — | — | — | — | — | — | — |

| | |
|-------------------|------------------------------------|
| Legend: | U = Unimplemented bit, read as '0' |
| R = Readable bit | W = Writable bit |
| -n = Value at POR | '1' = Bit is set |
| | '0' = Bit is cleared |
| | x = Bit is unknown |

bit 31-16 **Unimplemented:** Read as '0'

bit 15-8 **STEP1<7:0>:** Preclear Enable bits

01000000 = Enables the Deadman Timer Preclear (Step 1)

All other write patterns = Set BAD1 flag.

These bits are cleared when a DMT reset event occurs. STEP1<7:0> is also cleared if the STEP2<7:0> bits are loaded with the correct value in the correct sequence.

bit 7-0 **Unimplemented:** Read as '0'

PIC32MZ Embedded Connectivity with Floating Point Unit (EF) Family

REGISTER 15-3: DMTCLR: DEADMAN TIMER CLEAR REGISTER

| Bit Range | Bit 31/23/15/7 | Bit 30/22/14/6 | Bit 29/21/13/5 | Bit 28/20/12/4 | Bit 27/19/11/3 | Bit 26/18/10/2 | Bit 25/17/9/1 | Bit 24/16/8/0 |
|-----------|-------------------|-------------------|-------------------|-------------------|-------------------|-------------------|------------------|------------------|
| 31:24 | U-0 | U-0 | U-0 | U-0 | U-0 | U-0 | U-0 | U-0 |
| | — | — | — | — | — | — | — | — |
| 23:16 | U-0 | U-0 | U-0 | U-0 | U-0 | U-0 | U-0 | U-0 |
| | — | — | — | — | — | — | — | — |
| 15:8 | U-0 | U-0 | U-0 | U-0 | U-0 | U-0 | U-0 | U-0 |
| | — | — | — | — | — | — | — | — |
| 7:0 | R/W-0 | R/W-0 | R/W-0 | R/W-0 | R/W-0 | R/W-0 | R/W-0 | R/W-0 |
| | STEP2<7:0> | | | | | | | |

Legend:

| | | |
|-------------------|------------------|--|
| R = Readable bit | W = Writable bit | U = Unimplemented bit, read as '0' |
| -n = Value at POR | '1' = Bit is set | '0' = Bit is cleared x = Bit is unknown |

bit 31-8 **Unimplemented:** Read as '0'

bit 7-0 **STEP2<7:0>:** Clear Timer bits

00001000 = Clears STEP1<7:0>, STEP2<7:0> and the Deadman Timer if, and only if, preceded by correct loading of STEP1<7:0> bits in the correct sequence. The write to these bits may be verified by reading DMTCNT and observing the counter being reset.

All other write patterns = Set BAD2 bit, the value of STEP1<7:0> will remain unchanged, and the new value being written STEP2<7:0> will be captured. These bits are also cleared when a DMT reset event occurs.

PIC32MZ Embedded Connectivity with Floating Point Unit (EF) Family

REGISTER 15-4: DMTSTAT: DEADMAN TIMER STATUS REGISTER

| Bit Range | Bit 31/23/15/7 | Bit 30/22/14/6 | Bit 29/21/13/5 | Bit 28/20/12/4 | Bit 27/19/11/3 | Bit 26/18/10/2 | Bit 25/17/9/1 | Bit 24/16/8/0 |
|-----------|-------------------|-------------------|-------------------|-------------------|-------------------|-------------------|------------------|------------------|
| 31:24 | U-0 — | U-0 — | U-0 — | U-0 — | U-0 — | U-0 — | U-0 — | U-0 — |
| 23:16 | U-0 — | U-0 — | U-0 — | U-0 — | U-0 — | U-0 — | U-0 — | U-0 — |
| 15:8 | U-0 — | U-0 — | U-0 — | U-0 — | U-0 — | U-0 — | U-0 — | U-0 — |
| 7:0 | R-0, HC, HS | R-0, HC, HS | R-0, HC, HS | U-0 | U-0 | U-0 | U-0 | R-0, HC, HS |
| | BAD1 | BAD2 | DMTEVENT | — | — | — | — | WINOPN |

| | | |
|-------------------|-----------------------|--|
| Legend: | HC = Hardware Cleared | HS = Hardware Set |
| R = Readable bit | W = Writable bit | U = Unimplemented bit, read as '0' |
| -n = Value at POR | '1' = Bit is set | '0' = Bit is cleared x = Bit is unknown |

- bit 31-8 **Unimplemented:** Read as '0'
- bit 7 **BAD1:** Bad STEP1<7:0> Value Detect bit
 - 1 = Incorrect STEP1<7:0> value was detected
 - 0 = Incorrect STEP1<7:0> value was not detected
- bit 6 **BAD2:** Bad STEP2<7:0> Value Detect bit
 - 1 = Incorrect STEP2<7:0> value was detected
 - 0 = Incorrect STEP2<7:0> value was not detected
- bit 5 **DMTEVENT:** Deadman Timer Event bit
 - 1 = Deadman timer event was detected (counter expired or bad STEP1<7:0> or STEP2<7:0> value was entered prior to counter increment)
 - 0 = Deadman timer even was not detected
- bit 4-1 **Unimplemented:** Read as '0'
- bit 0 **WINOPN:** Deadman Timer Clear Window bit
 - 1 = Deadman timer clear window is open
 - 0 = Deadman timer clear window is not open

PIC32MZ Embedded Connectivity with Floating Point Unit (EF) Family

REGISTER 15-5: DMTCNT: DEADMAN TIMER COUNT REGISTER

| Bit Range | Bit 31/23/15/7 | Bit 30/22/14/6 | Bit 29/21/13/5 | Bit 28/20/12/4 | Bit 27/19/11/3 | Bit 26/18/10/2 | Bit 25/17/9/1 | Bit 24/16/8/0 |
|-----------|-------------------|-------------------|-------------------|-------------------|-------------------|-------------------|------------------|------------------|
| 31:24 | R-0 | R-0 | R-0 | R-0 | R-0 | R-0 | R-0 | R-0 |
| | COUNTER<31:24> | | | | | | | |
| 23:16 | R-0 | R-0 | R-0 | R-0 | R-0 | R-0 | R-0 | R-0 |
| | COUNTER<23:16> | | | | | | | |
| 15:8 | R-0 | R-0 | R-0 | R-0 | R-0 | R-0 | R-0 | R-0 |
| | COUNTER<15:8> | | | | | | | |
| 7:0 | R-0 | R-0 | R-0 | R-0 | R-0 | R-0 | R-0 | R-0 |
| | COUNTER<7:0> | | | | | | | |

Legend:

R = Readable bit W = Writable bit U = Unimplemented bit, read as '0'
-n = Value at POR '1' = Bit is set '0' = Bit is cleared x = Bit is unknown

bit 31-8 **COUNTER<31:0>**: Read current contents of DMT counter

REGISTER 15-6: DMTPSCNT: POST STATUS CONFIGURE DMT COUNT STATUS REGISTER

| Bit Range | Bit 31/23/15/7 | Bit 30/22/14/6 | Bit 29/21/13/5 | Bit 28/20/12/4 | Bit 27/19/11/3 | Bit 26/18/10/2 | Bit 25/17/9/1 | Bit 24/16/8/0 |
|-----------|-------------------|-------------------|-------------------|-------------------|-------------------|-------------------|------------------|------------------|
| 31:24 | R-0 | R-0 | R-0 | R-0 | R-0 | R-0 | R-0 | R-0 |
| | PSCNT<31:24> | | | | | | | |
| 23:16 | R-0 | R-0 | R-0 | R-0 | R-0 | R-0 | R-0 | R-0 |
| | PSCNT<23:16> | | | | | | | |
| 15:8 | R-0 | R-0 | R-0 | R-0 | R-0 | R-0 | R-0 | R-0 |
| | PSCNT<15:8> | | | | | | | |
| 7:0 | R-0 | R-0 | R-0 | R-y | R-y | R-y | R-y | R-y |
| | PSCNT<7:0> | | | | | | | |

Legend:

R = Readable bit W = Writable bit y = Value set from Configuration bits on POR
-n = Value at POR '1' = Bit is set '0' = Bit is cleared x = Bit is unknown

bit 31-8 **PSCNT<31:0>**: DMT Instruction Count Value Configuration Status bits
This is always the value of the DMTCNT<4:0> bits in the DEVCFG1 Configuration register.

PIC32MZ Embedded Connectivity with Floating Point Unit (EF) Family

REGISTER 15-7: DMTPSINTV: POST STATUS CONFIGURE DMT INTERVAL STATUS REGISTER

| Bit Range | Bit 31/23/15/7 | Bit 30/22/14/6 | Bit 29/21/13/5 | Bit 28/20/12/4 | Bit 27/19/11/3 | Bit 26/18/10/2 | Bit 25/17/9/1 | Bit 24/16/8/0 |
|-----------|-------------------|-------------------|-------------------|-------------------|-------------------|-------------------|------------------|------------------|
| 31:24 | R-0 | R-0 | R-0 | R-0 | R-0 | R-0 | R-0 | R-0 |
| | PSINTV<31:24> | | | | | | | |
| 23:16 | R-0 | R-0 | R-0 | R-0 | R-0 | R-0 | R-0 | R-0 |
| | PSINTV<23:16> | | | | | | | |
| 15:8 | R-0 | R-0 | R-0 | R-0 | R-0 | R-0 | R-0 | R-0 |
| | PSINTV<15:8> | | | | | | | |
| 7:0 | R-0 | R-0 | R-0 | R-0 | R-0 | R-y | R-y | R-y |
| | PSINTV<7:0> | | | | | | | |

Legend:

R = Readable bit
-n = Value at POR

W = Writable bit
'1' = Bit is set

y = Value set from Configuration bits on POR
U = Unimplemented bit, read as '0'
'0' = Bit is cleared
x = Bit is unknown

bit 31-8 **PSINTV<31:0>**: DMT Window Interval Configuration Status bits

This is always the value of the DMTINTV<2:0> bits in the DEVCFG1 Configuration register.

PIC32MZ Embedded Connectivity with Floating Point Unit (EF) Family

NOTES:

16.0 WATCHDOG TIMER (WDT)

Note: This data sheet summarizes the features of the PIC32MZ EF family of devices. It is not intended to be a comprehensive reference source. To complement the information in this data sheet, refer to **Section 9. “Watchdog, Deadman, and Power-up Timers”** (DS60001114) in the “PIC32 Family Reference Manual”, which is available from the Microchip web site (www.microchip.com/PIC32).

When enabled, the Watchdog Timer (WDT) operates from the internal Low-Power Oscillator (LPRC) clock source and can be used to detect system software malfunctions by resetting the device if the WDT is not cleared periodically in software. Various WDT time-out periods can be selected using the WDT postscaler. The WDT can also be used to wake the device from Sleep or Idle mode.

Key features of the WDT module include:

- Configuration or software controlled
- User-configurable time-out period
- Can wake the device from Sleep or Idle

FIGURE 16-1: WATCHDOG TIMER BLOCK DIAGRAM

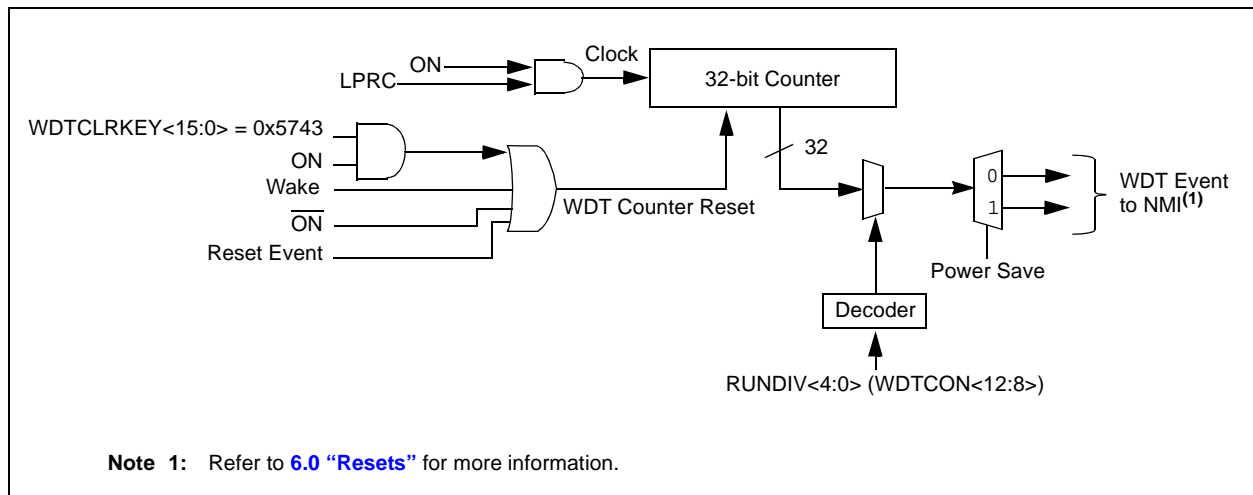

16.1 Watchdog Timer Control Registers

TABLE 16-1: WATCHDOG TIMER REGISTER MAP

| Virtual Address (BF80_#) | Register Name | Bit Range | Bits | | | | | | | | | | | | | | All Resets |
|-----------------------------|-----------------------|-----------|-----------------|-------|-------|-------------|-------|-------|------|------|------|------|------|------|------|------|------------|
| | | | 31/15 | 30/14 | 29/13 | 28/12 | 27/11 | 26/10 | 25/9 | 24/8 | 23/7 | 22/6 | 21/5 | 20/4 | 19/3 | 18/2 | |
| 0800 | WDTCON ⁽¹⁾ | 31:16 | WDTCLRKEY<15:0> | | | | | | | | | | | | | | 0000 |
| | | 15:0 | ON | — | — | RUNDIV<4:0> | | | | — | — | — | — | — | — | — | — |

Legend: x = unknown value on Reset; — = unimplemented, read as '0'. Reset values are shown in hexadecimal.

Note 1: This register has corresponding CLR, SET and INV registers at its virtual address, plus an offset of 0x4, 0x8 and 0xC, respectively. See [12.0 "I/O Ports"](#) for more information.

PIC32MZ Embedded Connectivity with Floating Point Unit (EF) Family

REGISTER 16-1: WDTCON: WATCHDOG TIMER CONTROL REGISTER

| Bit Range | Bit 31/23/15/7 | Bit 30/22/14/6 | Bit 29/21/13/5 | Bit 28/20/12/4 | Bit 27/19/11/3 | Bit 26/18/10/2 | Bit 25/17/9/1 | Bit 24/16/8/0 |
|-----------|-------------------|----------------|----------------|----------------|----------------|----------------|---------------|---------------|
| 31:24 | W-0 | W-0 | W-0 | W-0 | W-0 | W-0 | W-0 | W-0 |
| | WDTCLRKEY<15:8> | | | | | | | |
| 23:16 | W-0 | W-0 | W-0 | W-0 | W-0 | W-0 | W-0 | W-0 |
| | WDTCLRKEY<7:0> | | | | | | | |
| 15:8 | R/W-y | U-0 | U-0 | R-y | R-y | R-y | R-y | R-y |
| | ON ⁽¹⁾ | — | — | RUNDIV<4:0> | | | | |
| 7:0 | U-0 | U-0 | U-0 | U-0 | U-0 | U-0 | U-0 | R/W-0 |
| | — | — | — | — | — | — | — | WDTWINEN |

| | |
|-------------------|--|
| Legend: | y = Values set from Configuration bits on POR |
| R = Readable bit | W = Writable bit U = Unimplemented bit, read as '0' |
| -n = Value at POR | '1' = Bit is set '0' = Bit is cleared x = Bit is unknown |

- bit 31-16 **WDTCLRKEY:** Watchdog Timer Clear Key bits
To clear the Watchdog Timer to prevent a time-out, software must write the value 0x5743 to this location using a single 16-bit write.
- bit 15 **ON:** Watchdog Timer Enable bit⁽¹⁾
1 = The WDT is enabled
0 = The WDT is disabled
- bit 14-13 **Unimplemented:** Read as '0'
- bit 12-8 **RUNDIV<4:0>:** Watchdog Timer Postscaler Value bits
On reset, these bits are set to the values of the WDTPS<4:0> Configuration bits in DEVCFG1.
- bit 7-1 **Unimplemented:** Read as '0'
- bit 0 **WDTWINEN:** Watchdog Timer Window Enable bit
1 = Enable windowed Watchdog Timer
0 = Disable windowed Watchdog Timer

Note 1: This bit only has control when FWDTEN (DEVCFG1<23>) = 0.

PIC32MZ Embedded Connectivity with Floating Point Unit (EF) Family

NOTES:

17.0 INPUT CAPTURE

Note: This data sheet summarizes the features of the PIC32MZ EF family of devices. It is not intended to be a comprehensive reference source. To complement the information in this data sheet, refer to **Section 15. “Input Capture”** (DS60001122) of the “PIC32 Family Reference Manual”, which is available from the Microchip web site (www.microchip.com/PIC32).

The Input Capture module is useful in applications requiring frequency (period) and pulse measurement.

The Input Capture module captures the 16-bit or 32-bit value of the selected Time Base registers when an event occurs at the ICx pin.

Capture events are caused by the following:

- Capture timer value on every edge (rising and falling), specified edge first

• Prescaler capture event modes:

- Capture timer value on every 4th rising edge of input at ICx pin
- Capture timer value on every 16th rising edge of input at ICx pin

Each input capture channel can select between one of six 16-bit timers for the time base, or two of six 16-bit timers together to form a 32-bit timer. The selected timer can use either an internal or external clock.

Other operational features include:

- Device wake-up from capture pin during Sleep and Idle modes
- Interrupt on input capture event
- 4-word FIFO buffer for capture values; Interrupt optionally generated after 1, 2, 3, or 4 buffer locations are filled
- Input capture can also be used to provide additional sources of external interrupts

FIGURE 17-1: INPUT CAPTURE BLOCK DIAGRAM

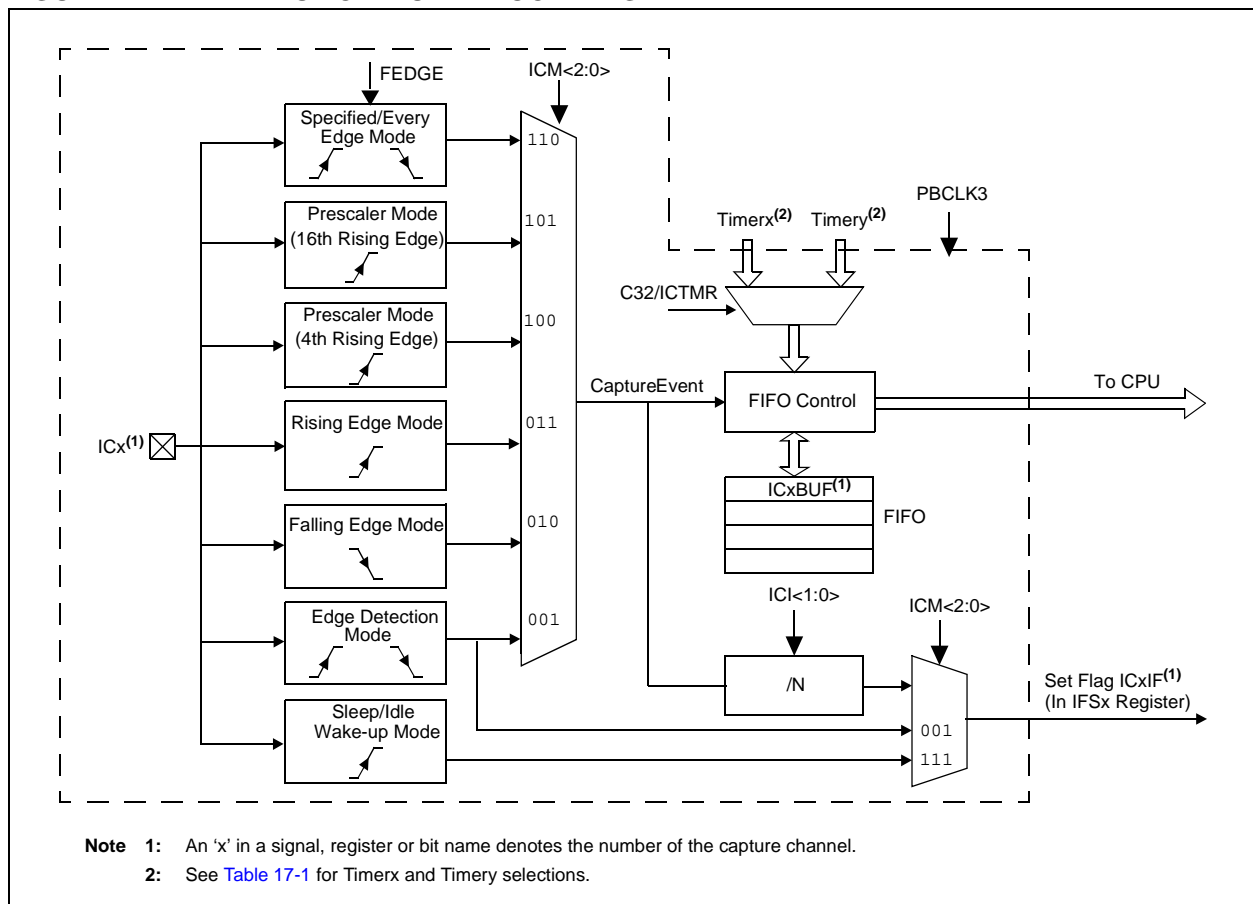

PIC32MZ Embedded Connectivity with Floating Point Unit (EF) Family

The timer source for each Input Capture module depends on the setting of the ICACLK bit in the CFGCON register. The available configurations are shown in [Table 17-1](#).

TABLE 17-1: TIMER SOURCE CONFIGURATIONS

| Input Capture Module | Timerx | Timery |
|-------------------------|---------|---------|
| ICACLK (CFGCON<17>) = 0 | | |
| IC1 | Timer2 | Timer3 |
| ⋮ | ⋮ | ⋮ |
| IC9 | Timer 2 | Timer 3 |
| ICACLK (CFGCON<17>) = 1 | | |
| IC1 | Timer4 | Timer5 |
| IC2 | Timer4 | Timer5 |
| IC3 | Timer4 | Timer5 |
| IC4 | Timer2 | Timer3 |
| IC5 | Timer2 | Timer3 |
| IC6 | Timer2 | Timer3 |
| IC7 | Timer6 | Timer7 |
| IC8 | Timer6 | Timer7 |
| IC9 | Timer6 | Timer7 |

17.1 Input Capture Control Registers

TABLE 17-2: INPUT CAPTURE 1 THROUGH INPUT CAPTURE 9 REGISTER MAP

| Virtual Address (BF84_#) | Register Name | Bit Range | Bits | | | | | | | | | | | | | | | | All Resets |
|-----------------------------|-----------------------|-----------|--------------|-------|-------|-------|-------|-------|-------|------|-------|----------|------|-------|----------|------|------|------|------------|
| | | | 31/15 | 30/14 | 29/13 | 28/12 | 27/11 | 26/10 | 25/9 | 24/8 | 23/7 | 22/6 | 21/5 | 20/4 | 19/3 | 18/2 | 17/1 | 16/0 | |
| 2000 | IC1CON ⁽¹⁾ | 31:16 | — | — | — | — | — | — | — | — | — | — | — | — | — | — | — | — | 0000 |
| | | 15:0 | ON | — | SIDL | — | — | — | FEDGE | C32 | ICTMR | ICI<1:0> | ICOV | ICBNE | ICM<2:0> | 0000 | | | |
| 2010 | IC1BUF | 31:16 | IC1BUF<31:0> | | | | | | | | | | | | | | | | xxxx |
| | | 15:0 | IC1BUF<31:0> | | | | | | | | | | | | | | | | xxxx |
| 2200 | IC2CON ⁽¹⁾ | 31:16 | — | — | — | — | — | — | — | — | — | — | — | — | — | — | — | — | 0000 |
| | | 15:0 | ON | — | SIDL | — | — | — | FEDGE | C32 | ICTMR | ICI<1:0> | ICOV | ICBNE | ICM<2:0> | 0000 | | | |
| 2210 | IC2BUF | 31:16 | IC2BUF<31:0> | | | | | | | | | | | | | | | | xxxx |
| | | 15:0 | IC2BUF<31:0> | | | | | | | | | | | | | | | | xxxx |
| 2400 | IC3CON ⁽¹⁾ | 31:16 | — | — | — | — | — | — | — | — | — | — | — | — | — | — | — | — | 0000 |
| | | 15:0 | ON | — | SIDL | — | — | — | FEDGE | C32 | ICTMR | ICI<1:0> | ICOV | ICBNE | ICM<2:0> | 0000 | | | |
| 2410 | IC3BUF | 31:16 | IC3BUF<31:0> | | | | | | | | | | | | | | | | xxxx |
| | | 15:0 | IC3BUF<31:0> | | | | | | | | | | | | | | | | xxxx |
| 2600 | IC4CON ⁽¹⁾ | 31:16 | — | — | — | — | — | — | — | — | — | — | — | — | — | — | — | — | 0000 |
| | | 15:0 | ON | — | SIDL | — | — | — | FEDGE | C32 | ICTMR | ICI<1:0> | ICOV | ICBNE | ICM<2:0> | 0000 | | | |
| 2610 | IC4BUF | 31:16 | IC4BUF<31:0> | | | | | | | | | | | | | | | | xxxx |
| | | 15:0 | IC4BUF<31:0> | | | | | | | | | | | | | | | | xxxx |
| 2800 | IC5CON ⁽¹⁾ | 31:16 | — | — | — | — | — | — | — | — | — | — | — | — | — | — | — | — | 0000 |
| | | 15:0 | ON | — | SIDL | — | — | — | FEDGE | C32 | ICTMR | ICI<1:0> | ICOV | ICBNE | ICM<2:0> | 0000 | | | |
| 2810 | IC5BUF | 31:16 | IC5BUF<31:0> | | | | | | | | | | | | | | | | xxxx |
| | | 15:0 | IC5BUF<31:0> | | | | | | | | | | | | | | | | xxxx |
| 2A00 | IC6CON ⁽¹⁾ | 31:16 | — | — | — | — | — | — | — | — | — | — | — | — | — | — | — | — | 0000 |
| | | 15:0 | ON | — | SIDL | — | — | — | FEDGE | C32 | ICTMR | ICI<1:0> | ICOV | ICBNE | ICM<2:0> | 0000 | | | |
| 2A10 | IC6BUF | 31:16 | IC6BUF<31:0> | | | | | | | | | | | | | | | | xxxx |
| | | 15:0 | IC6BUF<31:0> | | | | | | | | | | | | | | | | xxxx |
| 2C00 | IC7CON ⁽¹⁾ | 31:16 | — | — | — | — | — | — | — | — | — | — | — | — | — | — | — | — | 0000 |
| | | 15:0 | ON | — | SIDL | — | — | — | FEDGE | C32 | ICTMR | ICI<1:0> | ICOV | ICBNE | ICM<2:0> | 0000 | | | |
| 2C10 | IC7BUF | 31:16 | IC7BUF<31:0> | | | | | | | | | | | | | | | | xxxx |
| | | 15:0 | IC7BUF<31:0> | | | | | | | | | | | | | | | | xxxx |
| 2E00 | IC8CON ⁽¹⁾ | 31:16 | — | — | — | — | — | — | — | — | — | — | — | — | — | — | — | — | 0000 |
| | | 15:0 | ON | — | SIDL | — | — | — | FEDGE | C32 | ICTMR | ICI<1:0> | ICOV | ICBNE | ICM<2:0> | 0000 | | | |
| 2E10 | IC8BUF | 31:16 | IC8BUF<31:0> | | | | | | | | | | | | | | | | xxxx |
| | | 15:0 | IC8BUF<31:0> | | | | | | | | | | | | | | | | xxxx |
| 3000 | IC9CON ⁽¹⁾ | 31:16 | — | — | — | — | — | — | — | — | — | — | — | — | — | — | — | — | 0000 |
| | | 15:0 | ON | — | SIDL | — | — | — | FEDGE | C32 | ICTMR | ICI<1:0> | ICOV | ICBNE | ICM<2:0> | 0000 | | | |
| 3010 | IC9BUF | 31:16 | IC9BUF<31:0> | | | | | | | | | | | | | | | | xxxx |
| | | 15:0 | IC9BUF<31:0> | | | | | | | | | | | | | | | | xxxx |

Legend: x = unknown value on Reset; — = unimplemented, read as '0'. Reset values are shown in hexadecimal.

Note 1: This register has corresponding CLR, SET and INV registers at its virtual address, plus an offset of 0x4, 0x8 and 0xC, respectively. See [Section 12.3 “CLR, SET, and INV Registers”](#) for more information.

18.0 OUTPUT COMPARE

Note: This data sheet summarizes the features of the PIC32MZ EF family of devices. It is not intended to be a comprehensive reference source. To complement the information in this data sheet, refer to **Section 16. “Output Compare”** (DS60001111) in the *“PIC32 Family Reference Manual”*, which is available from the Microchip web site (www.microchip.com/PIC32).

The Output Compare module is used to generate a single pulse or a train of pulses in response to selected time base events.

For all modes of operation, the Output Compare module compares the values stored in the OCxR and/or the OCxRS registers to the value in the selected timer.

When a match occurs, the Output Compare module generates an event based on the selected mode of operation.

The following are some of the key features:

- Multiple Output Compare modules in a device
- Programmable interrupt generation on compare event
- Single and Dual Compare modes
- Single and continuous output pulse generation
- Pulse-Width Modulation (PWM) mode
- Hardware-based PWM Fault detection and automatic output disable
- Programmable selection of 16-bit or 32-bit time bases
- Can operate from either of two available 16-bit time bases or a single 32-bit time base
- ADC event trigger

FIGURE 18-1: OUTPUT COMPARE MODULE BLOCK DIAGRAM

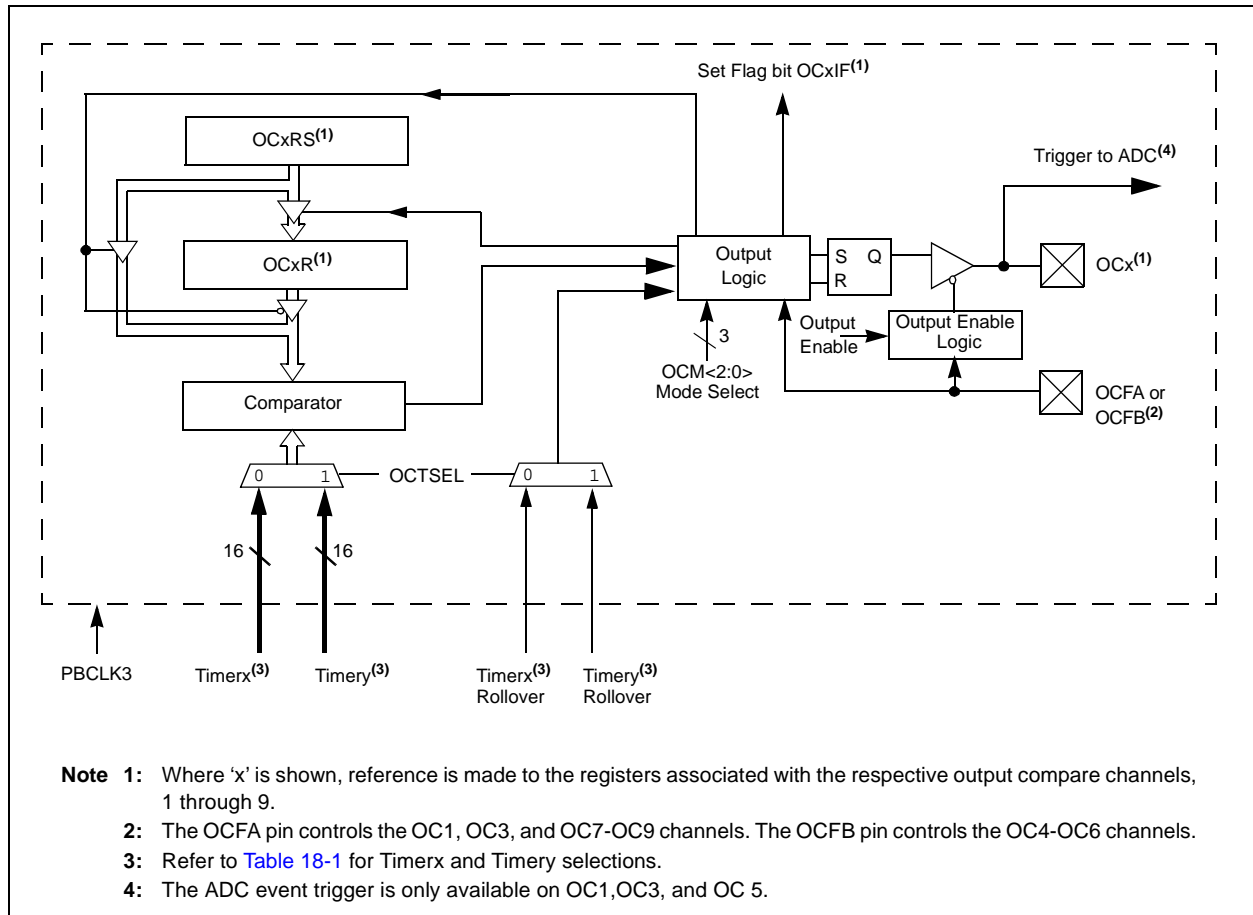

PIC32MZ Embedded Connectivity with Floating Point Unit (EF) Family

The timer source for each Output Compare module depends on the setting of the OCACLK bit in the CFGCON register. The available configurations are shown in [Table 18-1](#).

TABLE 18-1: TIMER SOURCE CONFIGURATIONS

| Output Compare Module | Timerx | Timery |
|-------------------------|---------|---------|
| OCACLK (CFGCON<16>) = 0 | | |
| OC1 | Timer2 | Timer3 |
| ⋮ | ⋮ | ⋮ |
| OC9 | Timer 2 | Timer 3 |
| OCACLK (CFGCON<16>) = 1 | | |
| OC1 | Timer4 | Timer5 |
| OC2 | Timer4 | Timer5 |
| OC3 | Timer4 | Timer5 |
| OC4 | Timer2 | Timer3 |
| OC5 | Timer2 | Timer3 |
| OC6 | Timer2 | Timer3 |
| OC7 | Timer6 | Timer7 |
| OC8 | Timer6 | Timer7 |
| OC9 | Timer6 | Timer7 |

18.1 Output Compare Control Registers

TABLE 18-2: OUTPUT COMPARE 1 THROUGH OUTPUT COMPARE 9 REGISTER MAP

| Virtual Address (BF84_#) | Register Name(r) | Bit Range | Bits | | | | | | | | | | | | | | | All Resets | |
|-----------------------------|---------------------|-----------|-------------|-------|-------|-------|-------|-------|------|------|------|------|------|------|-------|--------|----------|------------|------|
| | | | 31/15 | 30/14 | 29/13 | 28/12 | 27/11 | 26/10 | 25/9 | 24/8 | 23/7 | 22/6 | 21/5 | 20/4 | 19/3 | 18/2 | 17/1 | | 16/0 |
| 4000 | OC1CON | 31:16 | — | — | — | — | — | — | — | — | — | — | — | — | — | — | — | — | 0000 |
| | | 15:0 | ON | — | SIDL | — | — | — | — | — | — | — | — | OC32 | OCFLT | OCTSEL | OCM<2:0> | | 0000 |
| 4010 | OC1R | 31:16 | OC1R<31:0> | | | | | | | | | | | | | | | xxxx | |
| | | 15:0 | | | | | | | | | | | | | | | | xxxx | |
| 4020 | OC1RS | 31:16 | OC1RS<31:0> | | | | | | | | | | | | | | | xxxx | |
| | | 15:0 | | | | | | | | | | | | | | | | xxxx | |
| 4200 | OC2CON | 31:16 | — | — | — | — | — | — | — | — | — | — | — | — | — | — | — | — | 0000 |
| | | 15:0 | ON | — | SIDL | — | — | — | — | — | — | — | — | OC32 | OCFLT | OCTSEL | OCM<2:0> | | 0000 |
| 4210 | OC2R | 31:16 | OC2R<31:0> | | | | | | | | | | | | | | | xxxx | |
| | | 15:0 | | | | | | | | | | | | | | | | xxxx | |
| 4220 | OC2RS | 31:16 | OC2RS<31:0> | | | | | | | | | | | | | | | xxxx | |
| | | 15:0 | | | | | | | | | | | | | | | | xxxx | |
| 4400 | OC3CON | 31:16 | — | — | — | — | — | — | — | — | — | — | — | — | — | — | — | — | 0000 |
| | | 15:0 | ON | — | SIDL | — | — | — | — | — | — | — | — | OC32 | OCFLT | OCTSEL | OCM<2:0> | | 0000 |
| 4410 | OC3R | 31:16 | OC3R<31:0> | | | | | | | | | | | | | | | xxxx | |
| | | 15:0 | | | | | | | | | | | | | | | | xxxx | |
| 4420 | OC3RS | 31:16 | OC3RS<31:0> | | | | | | | | | | | | | | | xxxx | |
| | | 15:0 | | | | | | | | | | | | | | | | xxxx | |
| 4600 | OC4CON | 31:16 | — | — | — | — | — | — | — | — | — | — | — | — | — | — | — | — | 0000 |
| | | 15:0 | ON | — | SIDL | — | — | — | — | — | — | — | — | OC32 | OCFLT | OCTSEL | OCM<2:0> | | 0000 |
| 4610 | OC4R | 31:16 | OC4R<31:0> | | | | | | | | | | | | | | | xxxx | |
| | | 15:0 | | | | | | | | | | | | | | | | xxxx | |
| 4620 | OC4RS | 31:16 | OC4RS<31:0> | | | | | | | | | | | | | | | xxxx | |
| | | 15:0 | | | | | | | | | | | | | | | | xxxx | |
| 4800 | OC5CON | 31:16 | — | — | — | — | — | — | — | — | — | — | — | — | — | — | — | — | 0000 |
| | | 15:0 | ON | — | SIDL | — | — | — | — | — | — | — | — | OC32 | OCFLT | OCTSEL | OCM<2:0> | | 0000 |
| 4810 | OC5R | 31:16 | OC5R<31:0> | | | | | | | | | | | | | | | xxxx | |
| | | 15:0 | | | | | | | | | | | | | | | | xxxx | |
| 4820 | OC5RS | 31:16 | OC5RS<31:0> | | | | | | | | | | | | | | | xxxx | |
| | | 15:0 | | | | | | | | | | | | | | | | xxxx | |

Legend: x = unknown value on Reset; — = unimplemented, read as '0'. Reset values are shown in hexadecimal.

Note 1: All registers in this table have corresponding CLR, SET and INV registers at their virtual addresses, plus offsets of 0x4, 0x8 and 0xC, respectively. See [Section 12.3 "CLR, SET, and INV Registers"](#) for more information.

TABLE 18-2: OUTPUT COMPARE 1 THROUGH OUTPUT COMPARE 9 REGISTER MAP (CONTINUED)

| Virtual Address (BF94.#) | Register Name ⁽¹⁾ | Bit Range | Bits | | | | | | | | | | | | | | | | All Resets |
|-----------------------------|---------------------------------|-----------|-------------|-------|-------|-------|-------|-------|------|------|------|------|------|-------|--------|----------|------|------|------------|
| | | | 31/15 | 30/14 | 29/13 | 28/12 | 27/11 | 26/10 | 25/9 | 24/8 | 23/7 | 22/6 | 21/5 | 20/4 | 19/3 | 18/2 | 17/1 | 16/0 | |
| 4A00 | OC6CON | 31:16 | — | — | — | — | — | — | — | — | — | — | — | — | — | — | — | — | 0000 |
| | | 15:0 | ON | — | SIDL | — | — | — | — | — | — | — | OC32 | OCFLT | OCTSEL | OCM<2:0> | | | 0000 |
| 4A10 | OC6R | 31:16 | OC6R<31:0> | | | | | | | | | | | | | | | | xxxx |
| | | 15:0 | | | | | | | | | | | | | | | | | xxxx |
| 4A20 | OC6RS | 31:16 | OC6RS<31:0> | | | | | | | | | | | | | | | | xxxx |
| | | 15:0 | | | | | | | | | | | | | | | | | xxxx |
| 4C00 | OC7CON | 31:16 | — | — | — | — | — | — | — | — | — | — | — | — | — | — | — | — | 0000 |
| | | 15:0 | ON | — | SIDL | — | — | — | — | — | — | — | OC32 | OCFLT | OCTSEL | OCM<2:0> | | | 0000 |
| 4C10 | OC7R | 31:16 | OC7R<31:0> | | | | | | | | | | | | | | | | xxxx |
| | | 15:0 | | | | | | | | | | | | | | | | | xxxx |
| 4C20 | OC7RS | 31:16 | OC7RS<31:0> | | | | | | | | | | | | | | | | xxxx |
| | | 15:0 | | | | | | | | | | | | | | | | | xxxx |
| 4E00 | OC8CON | 31:16 | — | — | — | — | — | — | — | — | — | — | — | — | — | — | — | — | 0000 |
| | | 15:0 | ON | — | SIDL | — | — | — | — | — | — | — | OC32 | OCFLT | OCTSEL | OCM<2:0> | | | 0000 |
| 4E10 | OC8R | 31:16 | OC8R<31:0> | | | | | | | | | | | | | | | | xxxx |
| | | 15:0 | | | | | | | | | | | | | | | | | xxxx |
| 4E20 | OC8RS | 31:16 | OC8RS<31:0> | | | | | | | | | | | | | | | | xxxx |
| | | 15:0 | | | | | | | | | | | | | | | | | xxxx |
| 5000 | OC9CON | 31:16 | — | — | — | — | — | — | — | — | — | — | — | — | — | — | — | — | 0000 |
| | | 15:0 | ON | — | SIDL | — | — | — | — | — | — | — | OC32 | OCFLT | OCTSEL | OCM<2:0> | | | 0000 |
| 5010 | OC9R | 31:16 | OC9R<31:0> | | | | | | | | | | | | | | | | xxxx |
| | | 15:0 | | | | | | | | | | | | | | | | | xxxx |
| 5020 | OC9RS | 31:16 | OC9RS<31:0> | | | | | | | | | | | | | | | | xxxx |
| | | 15:0 | | | | | | | | | | | | | | | | | xxxx |

Legend: x = unknown value on Reset; — = unimplemented, read as '0'. Reset values are shown in hexadecimal.

Note 1: All registers in this table have corresponding CLR, SET and INV registers at their virtual addresses, plus offsets of 0x4, 0x8 and 0xC, respectively. See [Section 12.3 "CLR, SET, and INV Registers"](#) for more information.

PIC32MZ Embedded Connectivity with Floating Point Unit (EF) Family

REGISTER 18-1: OCxCON: OUTPUT COMPARE 'x' CONTROL REGISTER

| Bit Range | Bit 31/23/15/7 | Bit 30/22/14/6 | Bit 29/21/13/5 | Bit 28/20/12/4 | Bit 27/19/11/3 | Bit 26/18/10/2 | Bit 25/17/9/1 | Bit 24/16/8/0 |
|-----------|----------------|----------------|----------------|----------------------|-----------------------|----------------|---------------|---------------|
| 31:24 | U-0 — | U-0 — | U-0 — | U-0 — | U-0 — | U-0 — | U-0 — | U-0 — |
| 23:16 | U-0 — | U-0 — | U-0 — | U-0 — | U-0 — | U-0 — | U-0 — | U-0 — |
| 15:8 | R/W-0 | U-0 | R/W-0 | U-0 | U-0 | U-0 | U-0 | U-0 |
| | ON | — | SIDL | — | — | — | — | — |
| 7:0 | U-0 | U-0 | R/W-0 | R-0 | R/W-0 | R/W-0 | R/W-0 | R/W-0 |
| | — | — | OC32 | OCFLT ⁽¹⁾ | OCTSEL ⁽²⁾ | OCM<2:0> | | |

Legend:

| | | |
|-------------------|------------------|--|
| R = Readable bit | W = Writable bit | U = Unimplemented bit, read as '0' |
| -n = Value at POR | '1' = Bit is set | '0' = Bit is cleared x = Bit is unknown |

bit 31-16 **Unimplemented:** Read as '0'

bit 15 **ON:** Output Compare Peripheral On bit
 1 = Output Compare peripheral is enabled
 0 = Output Compare peripheral is disabled

bit 14 **Unimplemented:** Read as '0'

bit 13 **SIDL:** Stop in Idle Mode bit
 1 = Discontinue operation when CPU enters Idle mode
 0 = Continue operation in Idle mode

bit 12-6 **Unimplemented:** Read as '0'

bit 5 **OC32:** 32-bit Compare Mode bit
 1 = OCxR<31:0> and/or OCxRS<31:0> are used for comparisons to the 32-bit timer source
 0 = OCxR<15:0> and OCxRS<15:0> are used for comparisons to the 16-bit timer source

bit 4 **OCFLT:** PWM Fault Condition Status bit⁽¹⁾
 1 = PWM Fault condition has occurred (cleared in HW only)
 0 = No PWM Fault condition has occurred

bit 3 **OCTSEL:** Output Compare Timer Select bit⁽²⁾
 1 = Timery is the clock source for this Output Compare module
 0 = Timerx is the clock source for this Output Compare module

bit 2-0 **OCM<2:0>:** Output Compare Mode Select bits
 111 = PWM mode on OCx; Fault pin enabled
 110 = PWM mode on OCx; Fault pin disabled
 101 = Initialize OCx pin low; generate continuous output pulses on OCx pin
 100 = Initialize OCx pin low; generate single output pulse on OCx pin
 011 = Compare event toggles OCx pin
 010 = Initialize OCx pin high; compare event forces OCx pin low
 001 = Initialize OCx pin low; compare event forces OCx pin high
 000 = Output compare peripheral is disabled but continues to draw current

Note 1: This bit is only used when OCM<2:0> = '111'. It is read as '0' in all other modes.

Note 2: Refer to [Table 18-1](#) for Timerx and Timery selections.

PIC32MZ Embedded Connectivity with Floating Point Unit (EF) Family

NOTES:

19.0 SERIAL PERIPHERAL INTERFACE (SPI) AND INTER-IC SOUND (I²S)

Note: This data sheet summarizes the features of the PIC32MZ EF family of devices. It is not intended to be a comprehensive reference source. To complement the information in this data sheet, refer to **Section 23. “Serial Peripheral Interface (SPI)”** (DS60001106) in the “PIC32 Family Reference Manual”, which is available from the Microchip web site (www.microchip.com/PIC32).

The SPI/I²S module is a synchronous serial interface that is useful for communicating with external peripherals and other microcontroller devices, as well as digital audio devices. These peripheral devices may be Serial EEPROMs, Shift registers, display drivers, Analog-to-Digital Converters (ADC), etc.

The SPI/I²S module is compatible with Motorola® SPI and SIOP interfaces.

Key features of the SPI module include:

- Master and Slave modes support
- Four different clock formats
- Enhanced Framed SPI protocol support
- User-configurable 8-bit, 16-bit and 32-bit data width
- Separate SPI FIFO buffers for receive and transmit
 - FIFO buffers act as 4/8/16-level deep FIFOs based on 32/16/8-bit data width
- Programmable interrupt event on every 8-bit, 16-bit and 32-bit data transfer
- Operation during Sleep and Idle modes
- Audio Codec Support:
 - I²S protocol
 - Left-justified
 - Right-justified
 - PCM

FIGURE 19-1: SPI/I²S MODULE BLOCK DIAGRAM

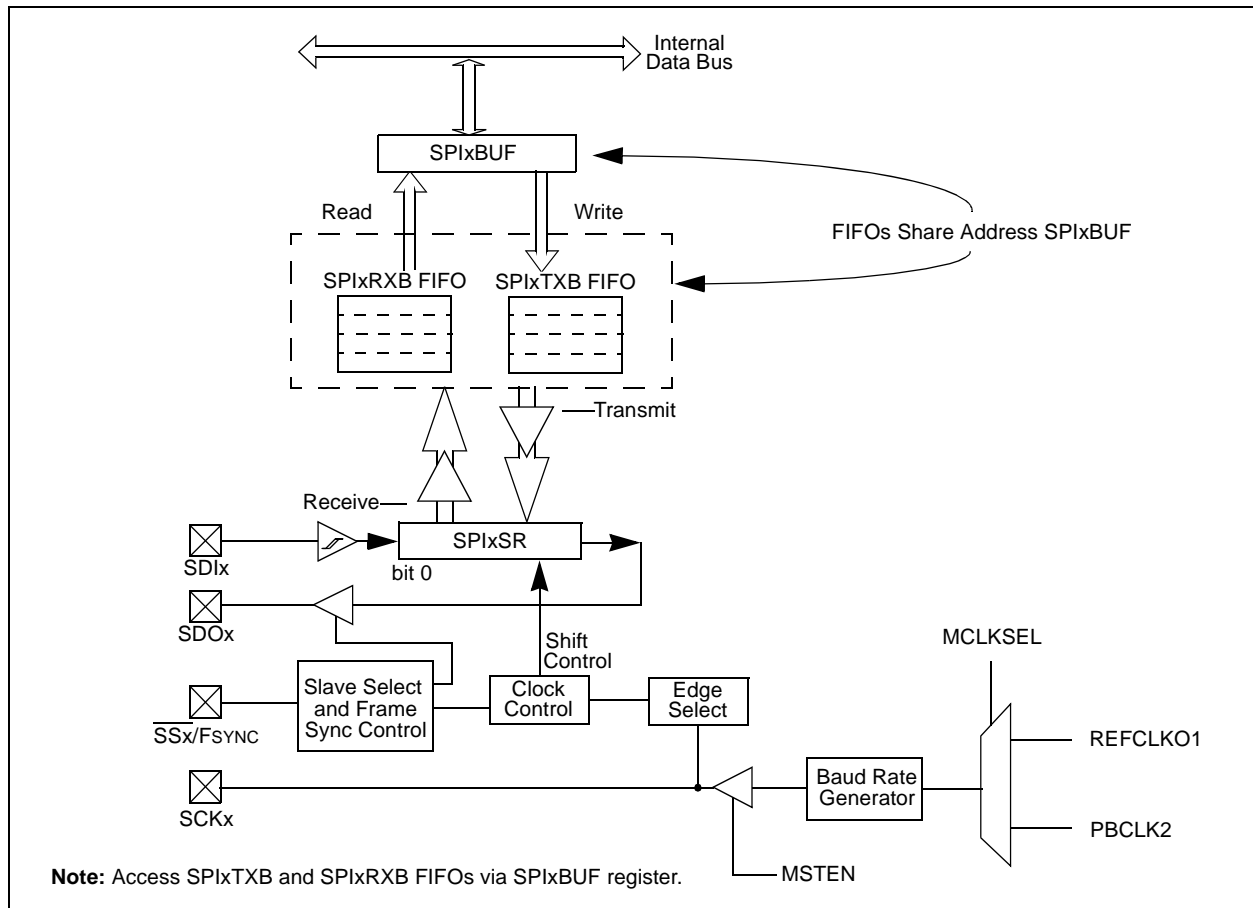

19.1 SPI Control Registers

TABLE 19-1: SPI1 THROUGH SPI6 REGISTER MAP

| Virtual Address (BF82_#) | Register Name(1) | Bit Range | Bits | | | | | | | | | | | | | | | All Resets | |
|--------------------------|------------------|-----------|------------|---------|--------|---------------|-----------|-------------|--------|--------|---------|--------|---------------|--------|--------------|--------------|-------------|------------|------|
| | | | 31/15 | 30/14 | 29/13 | 28/12 | 27/11 | 26/10 | 25/9 | 24/8 | 23/7 | 22/6 | 21/5 | 20/4 | 19/3 | 18/2 | 17/1 | | 16/0 |
| 1000 | SPI1CON | 31:16 | FRMEN | FRMSYNC | FRMPOL | MSEN | FRMSYPW | FRMCNT<2:0> | | | MCLKSEL | — | — | — | — | — | SPIFE | ENHBUF | 0000 |
| | | 15:0 | ON | — | SIDL | DISSDO | MODE32 | MODE16 | SMP | CKE | SSEN | CKP | MSTEN | DISSDI | STXISEL<1:0> | SRXISEL<1:0> | 0000 | | |
| 1010 | SPI1STAT | 31:16 | — | — | — | RXBUFELM<4:0> | | | | — | — | — | TXBUFELM<4:0> | | | | 0000 | | |
| | | 15:0 | — | — | — | FRMERR | SPIBUSY | — | — | SPITUR | SRMT | SPIROV | SPIRBE | — | SPITBE | — | SPITBF | SPIRBF | 0008 |
| 1020 | SPI1BUF | 31:16 | DATA<31:0> | | | | | | | | | | | | | | | 0000 | |
| | | 15:0 | | | | | | | | | | | | | | | | 0000 | |
| 1030 | SPI1BRG | 31:16 | — | — | — | — | — | — | — | — | — | — | — | — | — | — | — | — | 0000 |
| | | 15:0 | BRG<12:0> | | | | | | | | | | | | | | | 0000 | |
| 1040 | SPI1CON2 | 31:16 | — | — | — | — | — | — | — | — | — | — | — | — | — | — | — | — | 0000 |
| | | 15:0 | SPI SGNEXT | — | — | FRM ERREN | SPI ROVEN | SPI TUREN | IGNROV | IGNTUR | AUDEN | — | — | — | AUD MONO | — | AUDMOD<1:0> | | 0000 |
| 1200 | SPI2CON | 31:16 | FRMEN | FRMSYNC | FRMPOL | MSEN | FRMSYPW | FRMCNT<2:0> | | | MCLKSEL | — | — | — | — | — | SPIFE | ENHBUF | 0000 |
| | | 15:0 | ON | — | SIDL | DISSDO | MODE32 | MODE16 | SMP | CKE | SSEN | CKP | MSTEN | DISSDI | STXISEL<1:0> | SRXISEL<1:0> | 0000 | | |
| 1210 | SPI2STAT | 31:16 | — | — | — | RXBUFELM<4:0> | | | | — | — | — | TXBUFELM<4:0> | | | | 0000 | | |
| | | 15:0 | — | — | — | FRMERR | SPIBUSY | — | — | SPITUR | SRMT | SPIROV | SPIRBE | — | SPITBE | — | SPITBF | SPIRBF | 0008 |
| 1220 | SPI2BUF | 31:16 | DATA<31:0> | | | | | | | | | | | | | | | 0000 | |
| | | 15:0 | | | | | | | | | | | | | | | | 0000 | |
| 1230 | SPI2BRG | 31:16 | — | — | — | — | — | — | — | — | — | — | — | — | — | — | — | — | 0000 |
| | | 15:0 | BRG<8:0> | | | | | | | | | | | | | | | 0000 | |
| 1240 | SPI2CON2 | 31:16 | — | — | — | — | — | — | — | — | — | — | — | — | — | — | — | — | 0000 |
| | | 15:0 | SPI SGNEXT | — | — | FRM ERREN | SPI ROVEN | SPI TUREN | IGNROV | IGNTUR | AUDEN | — | — | — | AUD MONO | — | AUDMOD<1:0> | | 0000 |
| 1400 | SPI3CON | 31:16 | FRMEN | FRMSYNC | FRMPOL | MSEN | FRMSYPW | FRMCNT<2:0> | | | MCLKSEL | — | — | — | — | — | SPIFE | ENHBUF | 0000 |
| | | 15:0 | ON | — | SIDL | DISSDO | MODE32 | MODE16 | SMP | CKE | SSEN | CKP | MSTEN | DISSDI | STXISEL<1:0> | SRXISEL<1:0> | 0000 | | |
| 1410 | SPI3STAT | 31:16 | — | — | — | RXBUFELM<4:0> | | | | — | — | — | TXBUFELM<4:0> | | | | 0000 | | |
| | | 15:0 | — | — | — | FRMERR | SPIBUSY | — | — | SPITUR | SRMT | SPIROV | SPIRBE | — | SPITBE | — | SPITBF | SPIRBF | 0008 |
| 1420 | SPI3BUF | 31:16 | DATA<31:0> | | | | | | | | | | | | | | | 0000 | |
| | | 15:0 | | | | | | | | | | | | | | | | 0000 | |
| 1430 | SPI3BRG | 31:16 | — | — | — | — | — | — | — | — | — | — | — | — | — | — | — | — | 0000 |
| | | 15:0 | BRG<8:0> | | | | | | | | | | | | | | | 0000 | |
| 1440 | SPI3CON2 | 31:16 | — | — | — | — | — | — | — | — | — | — | — | — | — | — | — | — | 0000 |
| | | 15:0 | SPI SGNEXT | — | — | FRM ERREN | SPI ROVEN | SPI TUREN | IGNROV | IGNTUR | AUDEN | — | — | — | AUD MONO | — | AUDMOD<1:0> | | 0000 |

Legend: x = unknown value on Reset; — = unimplemented, read as '0'. Reset values are shown in hexadecimal.

Note 1: All registers in this table except SPIxBUF have corresponding CLR, SET and INV registers at their virtual addresses, plus offsets of 0x4, 0x8 and 0xC, respectively. See [Section 12.3 “CLR, SET, and INV Registers”](#) for more information.

TABLE 19-1: SPI1 THROUGH SPI6 REGISTER MAP (CONTINUED)

| Virtual Address (BF82_#) | Register Name ⁽¹⁾ | Bit Range | Bits | | | | | | | | | | | | | | | All Resets | |
|-----------------------------|---------------------------------|-----------|---------------|---------|--------|---------------|--------------|--------------|--------|--------|----------|--------|---------------|--------|--------------|--------------|-------------|------------|------|
| | | | 31/15 | 30/14 | 29/13 | 28/12 | 27/11 | 26/10 | 25/9 | 24/8 | 23/7 | 22/6 | 21/5 | 20/4 | 19/3 | 18/2 | 17/1 | | 16/0 |
| 1600 | SPI4CON | 31:16 | FRMEN | FRMSYNC | FRMPOL | MSEN | FRMSYPW | FRMCNT<2:0> | | | MCLKSEL | — | — | — | — | — | SPIFE | ENHBUF | 0000 |
| | | 15:0 | ON | — | SIDL | DISSDO | MODE32 | MODE16 | SMP | CKE | SSEN | CKP | MSTEN | DISSDI | STXISEL<1:0> | SRXISEL<1:0> | — | — | 0000 |
| 1610 | SPI4STAT | 31:16 | — | — | — | RXBUFELM<4:0> | | | | — | — | — | TXBUFELM<4:0> | | | | 0000 | | |
| | | 15:0 | — | — | — | FRMERR | SPIBUSY | — | — | SPITUR | SRMT | SPIROV | SPIRBE | — | SPIBTE | — | SPIBTF | SPIRBF | 0008 |
| 1620 | SPI4BUF | 31:16 | DATA<31:0> | | | | | | | | | | | | | | | 0000 | |
| | | 15:0 | | | | | | | | | | | | | | | | 0000 | |
| 1630 | SPI4BRG | 31:16 | — | — | — | — | — | — | — | — | — | — | — | — | — | — | — | — | 0000 |
| | | 15:0 | — | — | — | — | — | — | — | — | BRG<8:0> | | | | | | | | 0000 |
| 1640 | SPI4CON2 | 31:16 | — | — | — | — | — | — | — | — | — | — | — | — | — | — | — | — | 0000 |
| | | 15:0 | SPI SGNEXT | — | — | FRM ERREN | SPI ROVEN | SPI TUREN | IGNROV | IGNTUR | AUDEN | — | — | — | AUD MONO | — | AUDMOD<1:0> | — | 0000 |
| 1800 | SPI5CON | 31:16 | FRMEN | FRMSYNC | FRMPOL | MSEN | FRMSYPW | FRMCNT<2:0> | | | MCLKSEL | — | — | — | — | — | SPIFE | ENHBUF | 0000 |
| | | 15:0 | ON | — | SIDL | DISSDO | MODE32 | MODE16 | SMP | CKE | SSEN | CKP | MSTEN | DISSDI | STXISEL<1:0> | SRXISEL<1:0> | — | — | 0000 |
| 1810 | SPI5STAT | 31:16 | — | — | — | RXBUFELM<4:0> | | | | — | — | — | TXBUFELM<4:0> | | | | 0000 | | |
| | | 15:0 | — | — | — | FRMERR | SPIBUSY | — | — | SPITUR | SRMT | SPIROV | SPIRBE | — | SPIBTE | — | SPIBTF | SPIRBF | 0008 |
| 1820 | SPI5BUF | 31:16 | DATA<31:0> | | | | | | | | | | | | | | | 0000 | |
| | | 15:0 | | | | | | | | | | | | | | | | 0000 | |
| 1830 | SPI5BRG | 31:16 | — | — | — | — | — | — | — | — | — | — | — | — | — | — | — | — | 0000 |
| | | 15:0 | — | — | — | — | — | — | — | — | BRG<8:0> | | | | | | | | 0000 |
| 1840 | SPI5CON2 | 31:16 | — | — | — | — | — | — | — | — | — | — | — | — | — | — | — | — | 0000 |
| | | 15:0 | SPI SGNEXT | — | — | FRM ERREN | SPI ROVEN | SPI TUREN | IGNROV | IGNTUR | AUDEN | — | — | — | AUD MONO | — | AUDMOD<1:0> | — | 0000 |
| 1A00 | SPI6CON | 31:16 | FRMEN | FRMSYNC | FRMPOL | MSEN | FRMSYPW | FRMCNT<2:0> | | | MCLKSEL | — | — | — | — | — | SPIFE | ENHBUF | 0000 |
| | | 15:0 | ON | — | SIDL | DISSDO | MODE32 | MODE16 | SMP | CKE | SSEN | CKP | MSTEN | DISSDI | STXISEL<1:0> | SRXISEL<1:0> | — | — | 0000 |
| 1A10 | SPI6STAT | 31:16 | — | — | — | RXBUFELM<4:0> | | | | — | — | — | TXBUFELM<4:0> | | | | 0000 | | |
| | | 15:0 | — | — | — | FRMERR | SPIBUSY | — | — | SPITUR | SRMT | SPIROV | SPIRBE | — | SPIBTE | — | SPIBTF | SPIRBF | 0008 |
| 1A20 | SPI6BUF | 31:16 | DATA<31:0> | | | | | | | | | | | | | | | 0000 | |
| | | 15:0 | | | | | | | | | | | | | | | | 0000 | |
| 1A30 | SPI6BRG | 31:16 | — | — | — | — | — | — | — | — | — | — | — | — | — | — | — | — | 0000 |
| | | 15:0 | — | — | — | — | — | — | — | — | BRG<8:0> | | | | | | | | 0000 |
| 1A40 | SPI6CON2 | 31:16 | — | — | — | — | — | — | — | — | — | — | — | — | — | — | — | — | 0000 |
| | | 15:0 | SPI SGNEXT | — | — | FRM ERREN | SPI ROVEN | SPI TUREN | IGNROV | IGNTUR | AUDEN | — | — | — | AUD MONO | — | AUDMOD<1:0> | — | 0000 |

Legend: x = unknown value on Reset; — = unimplemented, read as '0'. Reset values are shown in hexadecimal.

Note 1: All registers in this table except SPIxBUF have corresponding CLR, SET and INV registers at their virtual addresses, plus offsets of 0x4, 0x8 and 0xC, respectively. See [Section 12.3 “CLR, SET, and INV Registers”](#) for more information.

PIC32MZ Embedded Connectivity with Floating Point Unit (EF) Family

REGISTER 19-1: SPIxCON: SPI CONTROL REGISTER (CONTINUED)

- bit 17 **SPIFE**: Frame Sync Pulse Edge Select bit (Framed SPI mode only)
 1 = Frame synchronization pulse coincides with the first bit clock
 0 = Frame synchronization pulse precedes the first bit clock
- bit 16 **ENHBUF**: Enhanced Buffer Enable bit⁽¹⁾
 1 = Enhanced Buffer mode is enabled
 0 = Enhanced Buffer mode is disabled
- bit 15 **ON**: SPI/I²S Module On bit
 1 = SPI/I²S module is enabled
 0 = SPI/I²S module is disabled
- bit 14 **Unimplemented**: Read as '0'
- bit 13 **SIDL**: Stop in Idle Mode bit
 1 = Discontinue operation when CPU enters in Idle mode
 0 = Continue operation in Idle mode
- bit 12 **DISSDO**: Disable SDOx pin bit⁽⁴⁾
 1 = SDOx pin is not used by the module. Pin is controlled by associated PORT register
 0 = SDOx pin is controlled by the module

bit 11-10 **MODE<32,16>**: 32/16-Bit Communication Select bits

When AUDEN = 1:

| MODE32 | MODE16 | Communication |
|--------|--------|---|
| 1 | 1 | 24-bit Data, 32-bit FIFO, 32-bit Channel/64-bit Frame |
| 1 | 0 | 32-bit Data, 32-bit FIFO, 32-bit Channel/64-bit Frame |
| 0 | 1 | 16-bit Data, 16-bit FIFO, 32-bit Channel/64-bit Frame |
| 0 | 0 | 16-bit Data, 16-bit FIFO, 16-bit Channel/32-bit Frame |

When AUDEN = 0:

| MODE32 | MODE16 | Communication |
|--------|--------|---------------|
| 1 | x | 32-bit |
| 0 | 1 | 16-bit |
| 0 | 0 | 8-bit |

- bit 9 **SMP**: SPI Data Input Sample Phase bit
Master mode (MSTEN = 1):
 1 = Input data sampled at end of data output time
 0 = Input data sampled at middle of data output time
Slave mode (MSTEN = 0):
 SMP value is ignored when SPI is used in Slave mode. The module always uses SMP = 0.
- bit 8 **CKE**: SPI Clock Edge Select bit⁽²⁾
 1 = Serial output data changes on transition from active clock state to Idle clock state (see CKP bit)
 0 = Serial output data changes on transition from Idle clock state to active clock state (see CKP bit)
- bit 7 **SSEN**: Slave Select Enable (Slave mode) bit
 1 = \overline{SSx} pin used for Slave mode
 0 = \overline{SSx} pin not used for Slave mode, pin controlled by port function.
- bit 6 **CKP**: Clock Polarity Select bit⁽³⁾
 1 = Idle state for clock is a high level; active state is a low level
 0 = Idle state for clock is a low level; active state is a high level

- Note 1:** This bit can only be written when the ON bit = 0. Refer to [Section 37.0 “Electrical Characteristics”](#) for maximum clock frequency requirements.
- 2:** This bit is not used in the Framed SPI mode. The user should program this bit to '0' for the Framed SPI mode (FRMEN = 1).
- 3:** When AUDEN = 1, the SPI/I²S module functions as if the CKP bit is equal to '1', regardless of the actual value of the CKP bit.
- 4:** This bit present for legacy compatibility and is superseded by PPS functionality on these devices (see [Section 12.4 “Peripheral Pin Select \(PPS\)”](#) for more information).

PIC32MZ Embedded Connectivity with Floating Point Unit (EF) Family

REGISTER 19-1: SPIxCON: SPI CONTROL REGISTER (CONTINUED)

- bit 5 **MSTEN**: Master Mode Enable bit
 1 = Master mode
 0 = Slave mode
- bit 4 **DISSDI**: Disable SDI bit⁽⁴⁾
 1 = SDI pin is not used by the SPI module (pin is controlled by PORT function)
 0 = SDI pin is controlled by the SPI module
- bit 3-2 **STXISEL<1:0>**: SPI Transmit Buffer Empty Interrupt Mode bits
 11 = Interrupt is generated when the buffer is not full (has one or more empty elements)
 10 = Interrupt is generated when the buffer is empty by one-half or more
 01 = Interrupt is generated when the buffer is completely empty
 00 = Interrupt is generated when the last transfer is shifted out of SPIxSR and transmit operations are complete
- bit 1-0 **SRXISEL<1:0>**: SPI Receive Buffer Full Interrupt Mode bits
 11 = Interrupt is generated when the buffer is full
 10 = Interrupt is generated when the buffer is full by one-half or more
 01 = Interrupt is generated when the buffer is not empty
 00 = Interrupt is generated when the last word in the receive buffer is read (i.e., buffer is empty)

- Note 1:** This bit can only be written when the ON bit = 0. Refer to [Section 37.0 “Electrical Characteristics”](#) for maximum clock frequency requirements.
- 2:** This bit is not used in the Framed SPI mode. The user should program this bit to ‘0’ for the Framed SPI mode (FRMEN = 1).
- 3:** When AUDEN = 1, the SPI/I²S module functions as if the CKP bit is equal to ‘1’, regardless of the actual value of the CKP bit.
- 4:** This bit present for legacy compatibility and is superseded by PPS functionality on these devices (see [Section 12.4 “Peripheral Pin Select \(PPS\)”](#) for more information).

PIC32MZ Embedded Connectivity with Floating Point Unit (EF) Family

REGISTER 19-2: SPIxCON2: SPI CONTROL REGISTER 2

| Bit Range | Bit 31/23/15/7 | Bit 30/22/14/6 | Bit 29/21/13/5 | Bit 28/20/12/4 | Bit 27/19/11/3 | Bit 26/18/10/2 | Bit 25/17/9/1 | Bit 24/16/8/0 |
|-----------|----------------------|----------------|----------------|----------------|--------------------------|----------------|------------------------------|---------------|
| 31:24 | U-0 | U-0 | U-0 | U-0 | U-0 | U-0 | U-0 | U-0 |
| | — | — | — | — | — | — | — | — |
| 23:16 | U-0 | U-0 | U-0 | U-0 | U-0 | U-0 | U-0 | U-0 |
| | — | — | — | — | — | — | — | — |
| 15:8 | R/W-0 | U-0 | U-0 | R/W-0 | R/W-0 | R/W-0 | R/W-0 | R/W-0 |
| | SPISGNEXT | — | — | FRMERREN | SPIROVEN | SPITUREN | IGNROV | IGNTUR |
| 7:0 | R/W-0 | U-0 | U-0 | U-0 | R/W-0 | U-0 | R/W-0 | R/W-0 |
| | AUDEN ⁽¹⁾ | — | — | — | AUDMONO ^(1,2) | — | AUDMOD<1:0> ^(1,2) | |

Legend:

R = Readable bit
-n = Value at POR

W = Writable bit
'1' = Bit is set

U = Unimplemented bit, read as '0'
'0' = Bit is cleared
x = Bit is unknown

- bit 31-16 **Unimplemented:** Read as '0'
- bit 15 **SPISGNEXT:** Sign Extend Read Data from the RX FIFO bit
 - 1 = Data from RX FIFO is sign extended
 - 0 = Data from RX FIFO is not sign extended
- bit 14-13 **Unimplemented:** Read as '0'
- bit 12 **FRMERREN:** Enable Interrupt Events via FRMERR bit
 - 1 = Frame Error overflow generates error events
 - 0 = Frame Error does not generate error events
- bit 11 **SPIROVEN:** Enable Interrupt Events via SPIROV bit
 - 1 = Receive overflow generates error events
 - 0 = Receive overflow does not generate error events
- bit 10 **SPITUREN:** Enable Interrupt Events via SPITUR bit
 - 1 = Transmit Underrun Generates Error Events
 - 0 = Transmit Underrun Does Not Generates Error Events
- bit 9 **IGNROV:** Ignore Receive Overflow bit (for Audio Data Transmissions)
 - 1 = A ROV is not a critical error; during ROV data in the FIFO is not overwritten by receive data
 - 0 = A ROV is a critical error which stop SPI operation
- bit 8 **IGNTUR:** Ignore Transmit Underrun bit (for Audio Data Transmissions)
 - 1 = A TUR is not a critical error and zeros are transmitted until the SPIxTXB is not empty
 - 0 = A TUR is a critical error which stop SPI operation
- bit 7 **AUDEN:** Enable Audio CODEC Support bit⁽¹⁾
 - 1 = Audio protocol enabled
 - 0 = Audio protocol disabled
- bit 6-5 **Unimplemented:** Read as '0'
- bit 3 **AUDMONO:** Transmit Audio Data Format bit^(1,2)
 - 1 = Audio data is mono (Each data word is transmitted on both left and right channels)
 - 0 = Audio data is stereo
- bit 2 **Unimplemented:** Read as '0'
- bit 1-0 **AUDMOD<1:0>:** Audio Protocol Mode bit^(1,2)
 - 11 = PCM/DSP mode
 - 10 = Right Justified mode
 - 01 = Left Justified mode
 - 00 = I²S mode

- Note 1:** This bit can only be written when the ON bit = 0.
Note 2: This bit is only valid for AUDEN = 1.

PIC32MZ Embedded Connectivity with Floating Point Unit (EF) Family

REGISTER 19-3: SPIxSTAT: SPI STATUS REGISTER

| Bit Range | Bit 31/23/15/7 | Bit 30/22/14/6 | Bit 29/21/13/5 | Bit 28/20/12/4 | Bit 27/19/11/3 | Bit 26/18/10/2 | Bit 25/17/9/1 | Bit 24/16/8/0 |
|-----------|----------------|----------------|----------------|----------------|----------------|----------------|---------------|---------------|
| 31:24 | U-0 | U-0 | U-0 | R-0 | R-0 | R-0 | R-0 | R-0 |
| | — | — | — | RXBUFELM<4:0> | | | | |
| 23:16 | U-0 | U-0 | U-0 | R-0 | R-0 | R-0 | R-0 | R-0 |
| | — | — | — | TXBUFELM<4:0> | | | | |
| 15:8 | U-0 | U-0 | U-0 | R/C-0, HS | R-0 | U-0 | U-0 | R-0 |
| | — | — | — | FRMERR | SPIBUSY | — | — | SPITUR |
| 7:0 | R-0 | R/W-0 | R-0 | U-0 | R-1 | U-0 | R-0 | R-0 |
| | SRMT | SPIROV | SPIRBE | — | SPITBE | — | SPITBF | SPIRBF |

| | | |
|-------------------|-------------------|--|
| Legend: | C = Clearable bit | HS = Set in hardware |
| R = Readable bit | W = Writable bit | U = Unimplemented bit, read as '0' |
| -n = Value at POR | '1' = Bit is set | '0' = Bit is cleared x = Bit is unknown |

- bit 31-29 **Unimplemented:** Read as '0'
- bit 28-24 **RXBUFELM<4:0>:** Receive Buffer Element Count bits (valid only when ENHBUF = 1)
- bit 23-21 **Unimplemented:** Read as '0'
- bit 20-16 **TXBUFELM<4:0>:** Transmit Buffer Element Count bits (valid only when ENHBUF = 1)
- bit 15-13 **Unimplemented:** Read as '0'
- bit 12 **FRMERR:** SPI Frame Error status bit
 - 1 = Frame error detected
 - 0 = No Frame error detected
 - This bit is only valid when FRMEN = 1.
- bit 11 **SPIBUSY:** SPI Activity Status bit
 - 1 = SPI peripheral is currently busy with some transactions
 - 0 = SPI peripheral is currently idle
- bit 10-9 **Unimplemented:** Read as '0'
- bit 8 **SPITUR:** Transmit Under Run bit
 - 1 = Transmit buffer has encountered an underrun condition
 - 0 = Transmit buffer has no underrun condition
 - This bit is only valid in Framed Sync mode; the underrun condition must be cleared by disabling/re-enabling the module.
- bit 7 **SRMT:** Shift Register Empty bit (valid only when ENHBUF = 1)
 - 1 = When SPI module shift register is empty
 - 0 = When SPI module shift register is not empty
- bit 6 **SPIROV:** Receive Overflow Flag bit
 - 1 = A new data is completely received and discarded. The user software has not read the previous data in the SPIxBUF register.
 - 0 = No overflow has occurred
 - This bit is set in hardware; can only be cleared (= 0) in software.
- bit 5 **SPIRBE:** RX FIFO Empty bit (valid only when ENHBUF = 1)
 - 1 = RX FIFO is empty (CRPTR = SWPTR)
 - 0 = RX FIFO is not empty (CRPTR ≠ SWPTR)
- bit 4 **Unimplemented:** Read as '0'

PIC32MZ Embedded Connectivity with Floating Point Unit (EF) Family

REGISTER 19-3: SPIxSTAT: SPI STATUS REGISTER

- bit 3 **SPITBE:** SPI Transmit Buffer Empty Status bit
 1 = Transmit buffer, SPIxTXB is empty
 0 = Transmit buffer, SPIxTXB is not empty
 Automatically set in hardware when SPI transfers data from SPIxTXB to SPIxSR.
 Automatically cleared in hardware when SPIxBUF is written to, loading SPIxTXB.
- bit 2 **Unimplemented:** Read as '0'
- bit 1 **SPITBF:** SPI Transmit Buffer Full Status bit
 1 = Transmit not yet started, SPITXB is full
 0 = Transmit buffer is not full
 Standard Buffer Mode:
 Automatically set in hardware when the core writes to the SPIBUF location, loading SPITXB.
 Automatically cleared in hardware when the SPI module transfers data from SPITXB to SPIxSR.
 Enhanced Buffer Mode:
 Set when CWPTR + 1 = SRPTR; cleared otherwise
- bit 0 **SPIRBF:** SPI Receive Buffer Full Status bit
 1 = Receive buffer, SPIxRXB is full
 0 = Receive buffer, SPIxRXB is not full
 Standard Buffer Mode:
 Automatically set in hardware when the SPI module transfers data from SPIxSR to SPIxRXB.
 Automatically cleared in hardware when SPIxBUF is read from, reading SPIxRXB.
 Enhanced Buffer Mode:
 Set when SWPTR + 1 = CRPTR; cleared otherwise

PIC32MZ Embedded Connectivity with Floating Point Unit (EF) Family

NOTES:

20.0 SERIAL QUAD INTERFACE (SQI)

Note: This data sheet summarizes the features of the PIC32MZ EF family of devices. It is not intended to be a comprehensive reference source. To complement the information in this data sheet, refer to **Section 46. “Serial Quad Interface (SQI)”** (DS60001244) in the *“PIC32 Family Reference Manual”*, which is available from the Microchip web site (www.microchip.com/PIC32).

The SQI module is a synchronous serial interface that provides access to serial Flash memories and other serial devices. The SQI module supports Single Lane (identical to SPI), Dual Lane, and Quad Lane modes.

Key features include:

- Supports Single, Dual, and Quad Lane modes
- Supports Single Data Rate (SDR) and Double Data Rate (DDR) modes
- Programmable command sequence
- eXecute-In-Place (XIP)

- Data transfer:
 - Programmed I/O mode (PIO)
 - Buffer descriptor DMA
- Supports SPI Mode 0 and Mode 3
- Programmable Clock Polarity (CPOL) and Clock Phase (CPHA) bits
- Supports up to two Chip Selects
- Supports up to four bytes of Flash address
- Programmable interrupt thresholds
- 32-byte transmit data buffer
- 32-byte receive data buffer
- 4-word controller buffer

Note: Once the SQI module is configured, external devices are memory mapped into KSEG2 and KSEG3 (see [Figure 4-1](#) through [Figure 4-2](#) in [Section 4.0 “Memory Organization”](#) for more information). The MMU must be enabled and the TLB must be set up to access this memory (refer to [Section 50. “CPU for Devices with MIPS32® microAptiv™ and M-Class Cores”](#) (DS60001192) of the *“PIC32 Family Reference Manual”* for more information).

FIGURE 20-1: SQI MODULE BLOCK DIAGRAM

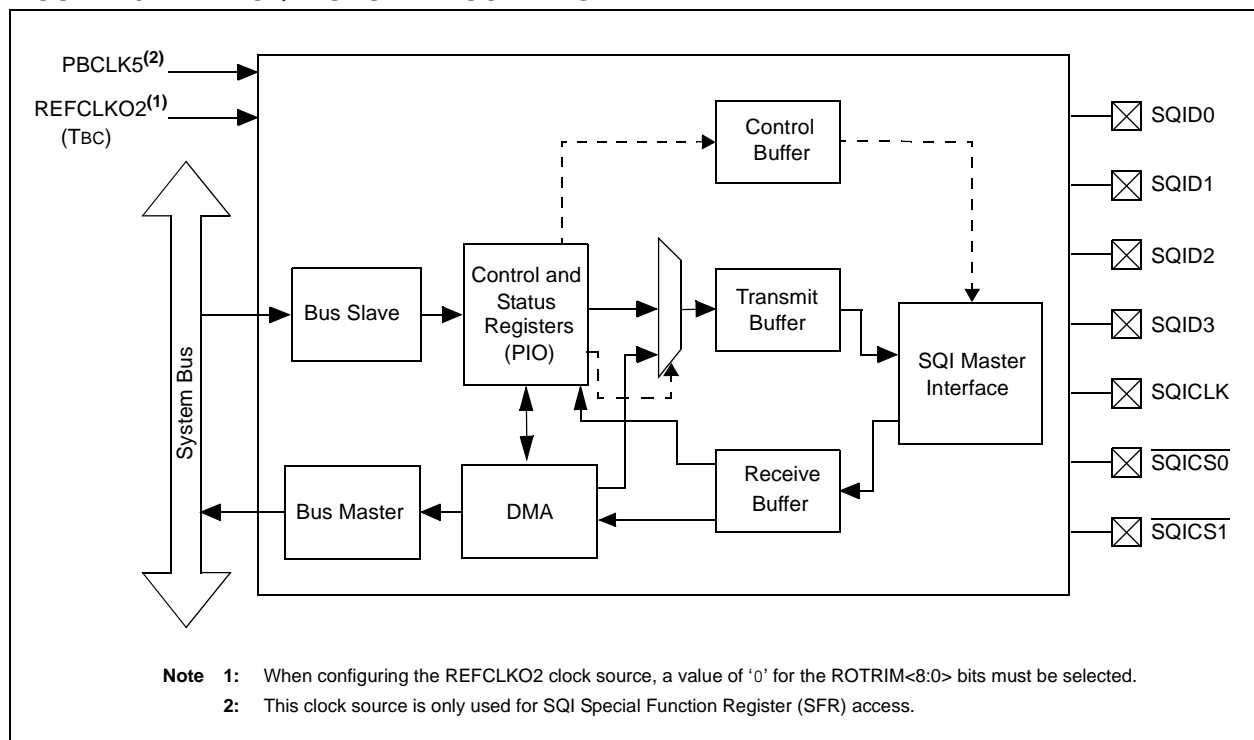

20.1 SQI Control Registers

TABLE 20-1: SERIAL QUADRATURE INTERFACE (SQI) REGISTER MAP

| Virtual Address (BF8E.#) | Register Name | Bit Range | Bits | | | | | | | | | | | | | | | All Resets | | | |
|-----------------------------|-------------------|-----------|-------------------|-------|-------|----------------|--------------|---------------|---------------|----------------|-----------------|-----------------|---------------|----------------|---------------|---------------|-----------------|---------------|-------|------|------|
| | | | 31/15 | 30/14 | 29/13 | 28/12 | 27/11 | 26/10 | 25/9 | 24/8 | 23/7 | 22/6 | 21/5 | 20/4 | 19/3 | 18/2 | 17/1 | | 16/0 | | |
| 2000 | SQI1 XCON1 | 31:16 | — | — | — | DDRDATA | DDR DUMMY | DDR MODE | DDR ADDR | DDRCMD | DUMMYBYTES<2:0> | | | ADDRBYTES<2:0> | | | READOPCODE<7:6> | | | 0000 | |
| | | 15:0 | READOPCODE<5:0> | | | | | TYPEDATA<1:0> | | TYPEDUMMY<1:0> | | TYPEMODE<1:0> | | TYPEADDR<1:0> | | TYPECMD<1:0> | | | 0000 | | |
| 2004 | SQI1 XCON2 | 31:16 | — | — | — | — | — | — | — | — | — | — | — | — | — | — | — | — | 0000 | | |
| | | 15:0 | DEVSEL<1:0> | | | MODEBYTES<1:0> | | | MODECODE<7:0> | | | | | | | | | 0000 | | | |
| 2008 | SQI1CFG | 31:16 | — | — | — | — | — | — | CSEN<1:0> | SQIEN | — | DATAEN<1:0> | | CON FIFORST | RXFIFO RST | TXFIFO RST | RESET | 0000 | | | |
| | | 15:0 | — | — | — | BURSTEN | — | HOLD | WP | — | — | LSBF | CPOL | CPHA | MODE<2:0> | | | 0000 | | | |
| 200C | SQI1CON | 31:16 | — | — | — | — | — | — | — | SCHECK | DDRMODE | DASSERT | DEVSEL<1:0> | | LANEMODE<1:0> | | CMDINIT<1:0> | | 0000 | | |
| | | 15:0 | TXRXCOUNT<15:0> | | | | | | | | | | | | | | | 0000 | | | |
| 2010 | SQI1 CLKCON | 31:16 | — | — | — | — | — | — | — | — | — | — | — | — | — | — | — | CLKDIV<9:8> | 0000 | | |
| | | 15:0 | CLKDIV<7:0> | | | | | | | | | | | | | | | 0000 | | | |
| 2014 | SQI1 CMDTHR | 31:16 | — | — | — | — | — | — | — | — | — | — | — | — | — | — | — | — | 0000 | | |
| | | 15:0 | TXCMDTHR<4:0> | | | | | — | | | | | RXCMDTHR<4:0> | | | | | 0000 | | | |
| 2018 | SQI1 INTTHR | 31:16 | — | — | — | — | — | — | — | — | — | — | — | — | — | — | — | — | 0000 | | |
| | | 15:0 | TXINTTHR<4:0> | | | | | — | | | | | RXINTTHR<4:0> | | | | | 0000 | | | |
| 201C | SQI1 INTEN | 31:16 | — | — | — | — | — | — | — | — | — | — | — | — | — | — | — | — | 0000 | | |
| | | 15:0 | — | — | — | — | DMAEIE | PKT COMPIE | BD DONEIE | CON THRIE | CON EMPTYIE | CON FULLIE | RX THRIE | RX FULLIE | RX EMPTYIE | TX THRIE | TX FULLIE | TX EMPTYIE | 0000 | | |
| 2020 | SQI1 INTSTAT | 31:16 | — | — | — | — | — | — | — | — | — | — | — | — | — | — | — | — | 0000 | | |
| | | 15:0 | — | — | — | — | DMAEIF | PKT COMPIF | BD DONEIF | CON THRIF | CON EMPTYIF | CON FULLIF | RX THRIF | RX FULLIF | RX EMPTYIF | TX THRIF | TX FULLIF | TX EMPTYIF | 0000 | | |
| 2024 | SQI1 TXDATA | 31:16 | TXDATA<31:16> | | | | | | | | | | | | | | | 0000 | | | |
| | | 15:0 | TXDATA<15:0> | | | | | | | | | | | | | | | 0000 | | | |
| 2028 | SQI1 RXDATA | 31:16 | RXDATA<31:16> | | | | | | | | | | | | | | | 0000 | | | |
| | | 15:0 | RXDATA<15:0> | | | | | | | | | | | | | | | 0000 | | | |
| 202C | SQI1 STAT1 | 31:16 | — | — | — | — | — | — | — | — | — | TXFIFOFREE<7:0> | | | | | | — | | | 0000 |
| | | 15:0 | — | — | — | — | — | — | — | — | — | RXFIFOCNT<7:0> | | | | | | — | | | 0000 |
| 2030 | SQI1 STAT2 | 31:16 | — | — | — | — | — | — | — | — | — | — | — | — | — | — | — | CMDSTAT<1:0> | 0000 | | |
| | | 15:0 | CONAVAIL<4:0> | | | | | — | | | | | SDID3 | SDID2 | SDID1 | SDID0 | — | RXUN | TXOV | 00x0 | |
| 2034 | SQI1 BDCON | 31:16 | — | — | — | — | — | — | — | — | — | — | — | — | — | — | — | — | 0000 | | |
| | | 15:0 | — | — | — | — | — | — | — | — | — | — | — | — | — | — | START | POLLEN | DMAEN | 0000 | |
| 2038 | SQI1BD CURADD | 31:16 | BDCURRADDR<31:16> | | | | | | | | | | | | | | | 0000 | | | |
| | | 15:0 | BDCURRADDR<15:0> | | | | | | | | | | | | | | | 0000 | | | |
| 2040 | SQI1BD BASEADD | 31:16 | BDADDR<31:16> | | | | | | | | | | | | | | | 0000 | | | |
| | | 15:0 | BDADDR<15:0> | | | | | | | | | | | | | | | 0000 | | | |

TABLE 20-1: SERIAL QUADRATURE INTERFACE (SQI) REGISTER MAP (CONTINUED)

| Virtual Address (BFSE #) | Register Name | Bit Range | Bits | | | | | | | | | | | | | | | All Resets |
|--------------------------|----------------|-----------|----------------|-------|---------------|--------------|-----------------|----------------|-----------------|-----------------|--------------|----------------|---------------|------------|---------------|----------------|------------|-------------|
| | | | 31/15 | 30/14 | 29/13 | 28/12 | 27/11 | 26/10 | 25/9 | 24/8 | 23/7 | 22/6 | 21/5 | 20/4 | 19/3 | 18/2 | 17/1 | |
| 2044 | SQI1BD STAT | 31:16 | — | — | — | — | — | — | — | — | — | — | BDSTATE<3:0> | | | DMA START | DMAACTV | 0000 |
| | | 15:0 | BDCON<15:0> | | | | | | | | | | | | | | | 0000 |
| 2048 | SQI1BD POLLCON | 31:16 | — | — | — | — | — | — | — | — | — | — | — | — | — | — | — | 0000 |
| | | 15:0 | POLLCON<15:0> | | | | | | | | | | | | | | | 0000 |
| 204C | SQI1BD TXDSTAT | 31:16 | — | — | — | TXSTATE<3:0> | | | — | — | — | — | TXBUFCNT<4:0> | | | | 0000 | |
| | | 15:0 | — | — | — | — | — | — | — | TXCURBUFLN<7:0> | | | | | | | 0000 | |
| 2050 | SQI1BD RXDSTAT | 31:16 | — | — | — | RXSTATE<3:0> | | | — | — | — | — | RXBUFCNT<4:0> | | | | 0000 | |
| | | 15:0 | — | — | — | — | — | — | — | RXCURBUFLN<7:0> | | | | | | | 0000 | |
| 2054 | SQI1THR | 31:16 | — | — | — | — | — | — | — | — | — | — | — | — | — | — | — | 0000 |
| | | 15:0 | THRES<6:0> | | | | | | | | | | | | | | | 0000 |
| 2058 | SQI1INT SIGEN | 31:16 | — | — | — | — | — | — | — | — | — | — | — | — | — | — | — | 0000 |
| | | 15:0 | — | — | — | — | DMAEISE | PKT DONEISE | BD DONEISE | CON THRISE | CON EMPTYISE | CON FULLISE | RX THRISE | RX FULLISE | RX EMPTYISE | TX THRISE | TX FULLISE | TX EMPTYISE |
| 205C | SQI1 TAPCON | 31:16 | — | — | — | — | — | — | — | — | — | — | — | — | — | — | — | 0000 |
| | | 15:0 | — | — | CLKINDLY<5:0> | | | | DATAOUTDLY<3:0> | | | CLKOUTDLY<3:0> | | | | | 0000 | |
| 2060 | SQI1 MEMSTAT | 31:16 | — | — | — | — | — | — | — | — | — | — | — | STATPOS | TYPESTAT<1:0> | STATBYTES<1:0> | 0000 | |
| | | 15:0 | STATDATA<15:0> | | | | | | | | | | | | | | | 0000 |
| 2064 | SQI1 XCON3 | 31:16 | — | — | — | INIT1 SCHECK | INIT1COUNT<1:0> | INIT1TYPE<1:0> | INIT1CMD3<7:0> | | | | | | | 0000 | | |
| | | 15:0 | INIT1CMD2<7:0> | | | | | | | INIT1CMD1<7:0> | | | | | | | 0000 | |
| 2068 | SQI1 XCON4 | 31:16 | — | — | — | INIT2 SCHECK | INIT2COUNT<1:0> | INIT2TYPE<1:0> | INIT2CMD3<7:0> | | | | | | | 0000 | | |
| | | 15:0 | INIT2CMD2<7:0> | | | | | | | INIT2CMD1<7:0> | | | | | | | 0000 | |

PIC32MZ Embedded Connectivity with Floating Point Unit (EF) Family

REGISTER 20-1: SQI1XCON1: SQI XIP CONTROL REGISTER 1

| Bit Range | Bit 31/23/15/7 | Bit 30/22/14/6 | Bit 29/21/13/5 | Bit 28/20/12/4 | Bit 27/19/11/3 | Bit 26/18/10/2 | Bit 25/17/9/1 | Bit 24/16/8/0 |
|-----------|-----------------|----------------|----------------|----------------|----------------|----------------|-----------------|---------------|
| 31:24 | U-0 | U-0 | U-0 | R/W-0 | R/W-0 | R/W-0 | R/W-0 | R/W-0 |
| | — | — | — | DDRDATA | DDR DUMMY | DDRMODE | DDRADDR | DDRCMD |
| 23:16 | R/W-0 | R/W-0 | R/W-0 | R/W-0 | R/W-0 | R/W-0 | R/W-0 | R/W-0 |
| | DUMMYBYTES<2:0> | | | ADDRBYTES<2:0> | | | READOPCODE<7:6> | |
| 15:8 | R/W-0 | R/W-0 | R/W-0 | R/W-0 | R/W-0 | R/W-0 | R/W-0 | R/W-0 |
| | READOPCODE<5:0> | | | | | | TYPEDATA<1:0> | |
| 7:0 | R/W-0 | R/W-0 | R/W-0 | R/W-0 | R/W-0 | R/W-0 | R/W-0 | R/W-0 |
| | TYPEDUMMY<1:0> | | TYPEMODE<1:0> | | TYPEADDR<1:0> | | TYPECMD<1:0> | |

Legend:

R = Readable bit W = Writable bit U = Unimplemented bit, read as '0'
-n = Value at POR '1' = Bit is set '0' = Bit is cleared x = Bit is unknown

bit 31-29 **Unimplemented:** Read as '0'

bit 28 **DDRDATA:** SQI Data DDR Mode bit

1 = SQI data bytes are transferred in DDR mode
0 = SQI data bytes are transferred in SDR mode

bit 27 **DDR DUMMY:** SQI Dummy DDR Mode bit

1 = SQI dummy bytes are transferred in DDR mode
0 = SQI dummy bytes are transferred in SDR mode

bit 26 **DDRMODE:** SQI DDR Mode bit

1 = SQI mode bytes are transferred in DDR mode
0 = SQI mode bytes are transferred in SDR mode

bit 25 **DDRADDR:** SQI Address Mode bit

1 = SQI address bytes are transferred in DDR mode
0 = SQI address bytes are transferred in SDR mode

bit 24 **DDRCMD:** SQI DDR Command Mode bit

1 = SQI command bytes are transferred in DDR mode
0 = SQI command bytes are transferred in SDR mode

bit 23-21 **DUMMYBYTES<2:0>:** Transmit Dummy Bytes bits

111 = Transmit seven dummy bytes after the address bytes

•
•
•

011 = Transmit three dummy bytes after the address bytes

010 = Transmit two dummy bytes after the address bytes

001 = Transmit one dummy bytes after the address bytes

000 = Transmit zero dummy bytes after the address bytes

bit 20-18 **ADDRBYTES<2:0>:** Address Cycle bits

111 = Reserved

•
•
•

101 = Reserved

100 = Four address bytes

011 = Three address bytes

010 = Two address bytes

001 = One address bytes

000 = Zero address bytes

PIC32MZ Embedded Connectivity with Floating Point Unit (EF) Family

REGISTER 20-1: SQI1XCON1: SQI XIP CONTROL REGISTER 1 (CONTINUED)

- bit 17-10 **READOPCODE<7:0>**: Op code Value for Read Operation bits
These bits contain the 8-bit op code value for read operation.
- bit 9-8 **TYPEDATA<1:0>**: SQI Type Data Enable bits
The boot controller will receive the data in Single Lane, Dual Lane, or Quad Lane.
11 = Reserved
10 = Quad Lane mode data is enabled
01 = Dual Lane mode data is enabled
00 = Single Lane mode data is enabled
- bit 7-6 **TYPEDUMMY<1:0>**: SQI Type Dummy Enable bits
The boot controller will send the dummy in Single Lane, Dual Lane, or Quad Lane.
11 = Reserved
10 = Quad Lane mode dummy is enabled
01 = Dual Lane mode dummy is enabled
00 = Single Lane mode dummy is enabled
- bit 5-4 **TYPEMODE<1:0>**: SQI Type Mode Enable bits
The boot controller will send the mode in Single Lane, Dual Lane, or Quad Lane.
11 = Reserved
10 = Quad Lane mode is enabled
01 = Dual Lane mode is enabled
00 = Single Lane mode is enabled
- bit 3-2 **TYPEADDR<1:0>**: SQI Type Address Enable bits
The boot controller will send the address in Single Lane, Dual Lane, or Quad Lane.
11 = Reserved
10 = Quad Lane mode address is enabled
01 = Dual Lane mode address is enabled
00 = Single Lane mode address is enabled
- bit 1-0 **TYPECMD<1:0>**: SQI Type Command Enable bits
The boot controller will send the command in Single Lane, Dual Lane, or Quad Lane.
11 = Reserved
10 = Quad Lane mode command is enabled
01 = Dual Lane mode command is enabled
00 = Single Lane mode command is enabled

PIC32MZ Embedded Connectivity with Floating Point Unit (EF) Family

REGISTER 20-2: SQI1XCON2: SQI XIP CONTROL REGISTER 2

| Bit Range | Bit 31/23/15/7 | Bit 30/22/14/6 | Bit 29/21/13/5 | Bit 28/20/12/4 | Bit 27/19/11/3 | Bit 26/18/10/2 | Bit 25/17/9/1 | Bit 24/16/8/0 |
|-----------|----------------|----------------|----------------|----------------|----------------|----------------|----------------|---------------|
| 31:24 | U-0 | U-0 | U-0 | U-0 | U-0 | U-0 | U-0 | U-0 |
| | — | — | — | — | — | — | — | — |
| 23:16 | U-0 | U-0 | U-0 | U-0 | U-0 | U-0 | U-0 | U-0 |
| | — | — | — | — | — | — | — | — |
| 15:8 | U-0 | U-0 | U-0 | U-0 | R/W-0 | R/W-0 | R/W-0 | R/W-0 |
| | — | — | — | — | DEVSEL<1:0> | | MODEBYTES<1:0> | |
| 7:0 | R/W-0 | R/W-0 | R/W-0 | R/W-0 | R/W-0 | R/W-0 | R/W-0 | R/W-0 |
| | MODECODE<7:0> | | | | | | | |

Legend:

R = Readable bit

W = Writable bit

U = Unimplemented bit, read as '0'

-n = Value at POR

'1' = Bit is set

'0' = Bit is cleared

x = Bit is unknown

bit 31-12 **Unimplemented:** Read as '0'

bit 11-10 **DEVSEL<1:0>:** Device Select bits

11 = Reserved

10 = Reserved

01 = Device 1 is selected

00 = Device 0 is selected

bit 9-8 **MODEBYTES<1:0>:** Mode Byte Cycle Enable bits

11 = Three cycles

10 = Two cycles

01 = One cycle

00 = Zero cycles

bit 7-0 **MODECODE<7:0>:** Mode Code Value bits

These bits contain the 8-bit code value for the mode bits.

PIC32MZ Embedded Connectivity with Floating Point Unit (EF) Family

REGISTER 20-3: SQI1CFG: SQI CONFIGURATION REGISTER

| Bit Range | Bit 31/23/15/7 | Bit 30/22/14/6 | Bit 29/21/13/5 | Bit 28/20/12/4 | Bit 27/19/11/3 | Bit 26/18/10/2 | Bit 25/17/9/1 | Bit 24/16/8/0 |
|-----------|----------------|----------------|----------------|------------------------|----------------|----------------|---------------|---------------|
| 31:24 | U-0 | U-0 | U-0 | U-0 | U-0 | U-0 | R/W-0 | R/W-0 |
| | — | — | — | — | — | — | CSEN<1:0> | |
| 23:16 | R/W-0 | U-0 | R/W-0 | R/W-0 | R/W-0, HC | R/W-0, HC | R/W-0, HC | R/W-0, HC |
| | SQIEN | — | DATAEN<1:0> | | CON FIFORST | RX FIFORST | TX FIFORST | RESET |
| 15:8 | U-0 | r-0 | r-0 | R/W-0 | r-0 | R/W-0 | R/W-0 | U-0 |
| | — | — | — | BURSTEN ⁽¹⁾ | — | HOLD | WP | — |
| 7:0 | U-0 | U-0 | R/W-0 | R/W-0 | R/W-0 | R/W-0 | R/W-0 | R/W-0 |
| | — | — | LSBF | CPOL | CPHA | MODE<2:0> | | |

| | | |
|-------------------|-----------------------|--|
| Legend: | HC = Hardware Cleared | r = Reserved |
| R = Readable bit | W = Writable bit | U = Unimplemented bit, read as '0' |
| -n = Value at POR | '1' = Bit is set | '0' = Bit is cleared x = Bit is unknown |

bit 31-26 **Unimplemented:** Read as '0'

bit 25-24 **CSEN<1:0>:** Chip Select Output Enable bits

- 11 = Chip Select 0 and Chip Select 1 are used
- 10 = Chip Select 1 is used (Chip Select 0 is not used)
- 01 = Chip Select 0 is used (Chip Select 1 is not used)
- 00 = Chip Select 0 and Chip Select 1 are not used

bit 23 **SQIEN:** SQI Enable bit

- 1 = SQI module is enabled
- 0 = SQI module is disabled

bit 22 **Unimplemented:** Read as '0'

bit 21-20 **DATAEN<1:0>:** Data Output Enable bits

- 11 = Reserved
- 10 = SQID3-SQID0 outputs are enabled
- 01 = SQID1 and SQID0 data outputs are enabled
- 00 = SQID0 data output is enabled

bit 19 **CONFIFORST:** Control FIFO Reset bit

- 1 = A reset pulse is generated clearing the control FIFO
- 0 = A reset pulse is not generated

bit 18 **RXFIFORST:** Receive FIFO Reset bit

- 1 = A reset pulse is generated clearing the receive FIFO
- 0 = A reset pulse is not generated

bit 17 **TXFIFORST:** Transmit FIFO Reset bit

- 1 = A reset pulse is generated clearing the transmit FIFO
- 0 = A reset pulse is not generated

bit 16 **RESET:** Software Reset Select bit

- This bit is automatically cleared by the SQI module. All of the internal state machines and FIFO pointers are reset by this reset pulse.
- 1 = A reset pulse is generated
- 0 = A reset pulse is not generated

bit 15 **Unimplemented:** Read as '0'

bit 14-13 **Reserved:** Must be programmed as '0'

Note 1: This bit must be programmed as '1'.

PIC32MZ Embedded Connectivity with Floating Point Unit (EF) Family

REGISTER 20-3: SQI1CFG: SQI CONFIGURATION REGISTER (CONTINUED)

- bit 12 **BURSTEN:** Burst Configuration bit⁽¹⁾
1 = Burst is enabled
0 = Burst is not enabled
- bit 11 **Reserved:** Must be programmed as '0'
- bit 10 **HOLD:** Hold bit
In Single Lane or Dual Lane mode, this bit is used to drive the SQID3 pin, which can be used for devices with a HOLD input pin. The meaning of the values for this bit will depend on the device to which SQID3 is connected.
- bit 9 **WP:** Write Protect bit
In Single Lane or Dual Lane mode, this bit is used to drive the SQID2 pin, which can be used with devices with a write-protect pin. The meaning of the values for this bit will depend on the device to which SQID2 is connected.
- bit 8-6 **Unimplemented:** Read as '0'
- bit 5 **LSBF:** Data Format Select bit
1 = LSB is sent or received first
0 = MSB is sent or received first
- bit 4 **CPOL:** Clock Polarity Select bit
1 = Active-low SQICLK (SQICLK high is the Idle state)
0 = Active-high SQICLK (SQICLK low is the Idle state)
- bit 3 **CPHA:** Clock Phase Select bit
1 = SQICLK starts toggling at the start of the first data bit
0 = SQICLK starts toggling at the middle of the first data bit
- bit 2-0 **MODE<2:0>:** Mode Select bits
111 = Reserved
•
•
•
100 = Reserved
011 = XIP mode is selected (when this mode is entered, the module behaves as if executing in place (XIP), but uses the register data to control timing)
010 = DMA mode is selected
001 = CPU mode is selected (the module is controlled by the CPU in PIO mode. This mode is entered when leaving Boot or XIP mode)
000 = Reserved

Note 1: This bit must be programmed as '1'.

PIC32MZ Embedded Connectivity with Floating Point Unit (EF) Family

REGISTER 20-4: SQ1CON: SQI CONTROL REGISTER

| Bit Range | Bit 31/23/15/7 | Bit 30/22/14/6 | Bit 29/21/13/5 | Bit 28/20/12/4 | Bit 27/19/11/3 | Bit 26/18/10/2 | Bit 25/17/9/1 | Bit 24/16/8/0 |
|-----------|-----------------|----------------|----------------|----------------|----------------|----------------|---------------|---------------|
| 31:24 | U-0 | U-0 | U-0 | U-0 | U-0 | U-0 | r-0 | R/W-0 |
| | — | — | — | — | — | — | — | SCHECK |
| 23:16 | R/W-0 | R/W-0 | R/W-0 | R/W-0 | R/W-0 | R/W-0 | R/W-0 | R/W-0 |
| | DDRMODE | DASSERT | DEVSEL<1:0> | | LANEMODE<1:0> | | CMDINIT<1:0> | |
| 15:8 | R/W-0 | R/W-0 | R/W-0 | R/W-0 | R/W-0 | R/W-0 | R/W-0 | R/W-0 |
| | TXRXCOUNT<15:8> | | | | | | | |
| 7:0 | R/W-0 | R/W-0 | R/W-0 | R/W-0 | R/W-0 | R/W-0 | R/W-0 | R/W-0 |
| | TXRXCOUNT<7:0> | | | | | | | |

| | |
|-------------------|------------------------------------|
| Legend: | r = Reserved |
| R = Readable bit | W = Writable bit |
| -n = Value at POR | '1' = Bit is set |
| | U = Unimplemented bit, read as '0' |
| | '0' = Bit is cleared |
| | x = Bit is unknown |

- bit 31-26 **Unimplemented:** Read as '0'
- bit 25 **Reserved:** Must be programmed as '0'
- bit 24 **SCHECK:** Flash Status Check bit
 - 1 = Check the status of the Flash
 - 0 = Do not check the status of the Flash
- bit 23 **DDRMODE:** Double Data Rate Mode bit
 - 1 = Set the SQI transfers to DDR mode
 - 0 = Set the SQI transfers to SDR mode
- bit 22 **DASSERT:** Chip Select Assert bit
 - 1 = Chip Select is deasserted after transmission or reception of the specified number of bytes
 - 0 = Chip Select is not deasserted after transmission or reception of the specified number of bytes
- bit 21-20 **DEVSEL<1:0>:** SQI Device Select bits
 - 11 = Reserved
 - 10 = Reserved
 - 01 = Select Device 1
 - 00 = Select Device 0
- bit 19-18 **LANEMODE<1:0>:** SQI Lane Mode Select bits
 - 11 = Reserved
 - 10 = Quad Lane mode
 - 01 = Dual Lane mode
 - 00 = Single Lane mode
- bit 17-16 **CMDINIT<1:0>:** Command Initiation Mode Select bits

If it is Transmit, commands are initiated based on a write to the transmit register or the contents of TX FIFO. If CMDINIT is Receive, commands are initiated based on reads to the read register or RX FIFO availability.

 - 11 = Reserved
 - 10 = Receive
 - 01 = Transmit
 - 00 = Idle
- bit 15-0 **TXRXCOUNT<15:0>:** Transmit/Receive Count bits

These bits specify the total number of bytes to transmit or received (based on CMDINIT)

PIC32MZ Embedded Connectivity with Floating Point Unit (EF) Family

REGISTER 20-5: SQI1CLKCON: SQI CLOCK CONTROL REGISTER

| Bit Range | Bit 31/23/15/7 | Bit 30/22/14/6 | Bit 29/21/13/5 | Bit 28/20/12/4 | Bit 27/19/11/3 | Bit 26/18/10/2 | Bit 25/17/9/1 | Bit 24/16/8/0 |
|-----------|----------------------------|----------------|----------------|----------------|----------------|----------------|----------------------------|---------------|
| 31:24 | U-0 | U-0 | U-0 | U-0 | U-0 | U-0 | U-0 | U-0 |
| | — | — | — | — | — | — | — | — |
| 23:16 | U-0 | U-0 | U-0 | U-0 | U-0 | U-0 | R/W-0 | R/W-0 |
| | — | — | — | — | — | — | CLKDIV<9:8> ⁽¹⁾ | |
| 15:8 | R/W-0 | R/W-0 | R/W-0 | R/W-0 | R/W-0 | R/W-0 | R/W-0 | R/W-0 |
| | CLKDIV<7:0> ⁽¹⁾ | | | | | | | |
| 7:0 | U-0 | U-0 | U-0 | U-0 | U-0 | U-0 | R-0 | R/W-0 |
| | — | — | — | — | — | — | STABLE | EN |

Legend:

R = Readable bit

W = Writable bit

U = Unimplemented bit, read as '0'

-n = Value at POR

'1' = Bit is set

'0' = Bit is cleared

x = Bit is unknown

bit 31-18 **Unimplemented:** Read as '0'

bit 17-8 **CLKDIV<9:0>:** SQI Clock Tsqi Frequency Select bit⁽¹⁾

1000000000 = Base clock TBC is divided by 2048

0100000000 = Base clock TBC is divided by 1024

0010000000 = Base clock TBC is divided by 512

0001000000 = Base clock TBC is divided by 256

0000100000 = Base clock TBC is divided by 128

0000010000 = Base clock TBC is divided by 64

0000001000 = Base clock TBC is divided by 32

0000000100 = Base clock TBC is divided by 16

0000000010 = Base clock TBC is divided by 8

0000000001 = Base clock TBC is divided by 4

0000000000 = Base clock TBC is divided by 2

Setting these bits to '00000000' specifies the highest frequency of the SQI clock.

bit 7-2 **Unimplemented:** Read as '0'

bit 1 **STABLE:** Tsqi Clock Stable Select bit

This bit is set to '1' when the SQI clock, Tsqi, is stable after writing a '1' to the EN bit.

1 = Tsqi clock is stable

0 = Tsqi clock is not stable

bit 0 **EN:** Tsqi Clock Enable Select bit

When clock oscillation is stable, the SQI module will set the STABLE bit to '1'.

1 = Enable the SQI clock (Tsqi) (when clock oscillation is stable, the SQI module sets the STABLE bit to '1')

0 = Disable the SQI clock (Tsqi) (the SQI module should stop its clock to enter a low power state); SFRs can still be accessed, as they use PBCLK5

Note 1: Refer to [Table](#) in [Section 44.0 "Electrical Characteristics"](#) for the maximum clock frequency specifications.

PIC32MZ Embedded Connectivity with Floating Point Unit (EF) Family

REGISTER 20-6: SQ1CMDTHR: SQI COMMAND THRESHOLD REGISTER

| Bit Range | Bit 31/23/15/7 | Bit 30/22/14/6 | Bit 29/21/13/5 | Bit 28/20/12/4 | Bit 27/19/11/3 | Bit 26/18/10/2 | Bit 25/17/9/1 | Bit 24/16/8/0 |
|-----------|----------------|----------------|----------------|------------------------------|----------------|----------------|---------------|---------------|
| 31:24 | U-0 | U-0 | U-0 | U-0 | U-0 | U-0 | U-0 | U-0 |
| | — | — | — | — | — | — | — | — |
| 23:16 | U-0 | U-0 | U-0 | U-0 | U-0 | U-0 | U-0 | U-0 |
| | — | — | — | — | — | — | — | — |
| 15:8 | U-0 | U-0 | U-0 | R/W-0 | R/W-0 | R/W-0 | R/W-0 | R/W-0 |
| | — | — | — | TXCMDTHR<4:0> | | | | |
| 7:0 | U-0 | U-0 | U-0 | R/W-0 | R/W-0 | R/W-0 | R/W-0 | R/W-0 |
| | — | — | — | RXCMDTHR<4:0> ⁽¹⁾ | | | | |

Legend:

R = Readable bit
-n = Value at POR

W = Writable bit
'1' = Bit is set

U = Unimplemented bit, read as '0'
'0' = Bit is cleared
x = Bit is unknown

bit 31-13 **Unimplemented:** Read as '0'

bit 12-8 **TXCMDTHR<4:0>:** Transmit Command Threshold bits

In transmit initiation mode, the SQI module performs a transmit operation when transmit command threshold bytes are present in the TX FIFO. These bits should usually be set to '1' for normal Flash commands, and set to a higher value for page programming. For 16-bit mode, the value should be a multiple of 2.

bit 7-5 **Unimplemented:** Read as '0'

bit 4-0 **RXCMDTHR<4:0>:** Receive Command Threshold bits⁽¹⁾

In receive initiation mode, the SQI module attempts to perform receive operations to fetch the receive command threshold number of bytes in the receive buffer. If space for these bytes is not present in the FIFO, the SQI will not initiate a transfer. For 16-bit mode, the value should be a multiple of 2.

If software performs any reads, thereby reducing the FIFO count, hardware would initiate a receive transfer to make the FIFO count equal to the value in these bits. If software would not like any more words latched into the FIFO, command initiation mode needs to be changed to Idle before any FIFO reads by software.

In the case of Boot/XIP mode, the SQI module will use the System Bus burst size, instead of the receive command threshold value.

Note 1: These bits should only be programmed when a receive is not active (i.e., during Idle mode or a transmit).

PIC32MZ Embedded Connectivity with Floating Point Unit (EF) Family

REGISTER 20-7: SQI1INTTHR: SQI INTERRUPT THRESHOLD REGISTER

| Bit Range | Bit 31/23/15/7 | Bit 30/22/14/6 | Bit 29/21/13/5 | Bit 28/20/12/4 | Bit 27/19/11/3 | Bit 26/18/10/2 | Bit 25/17/9/1 | Bit 24/16/8/0 |
|-----------|----------------|----------------|----------------|----------------|----------------|----------------|---------------|---------------|
| 31:24 | U-0 | U-0 | U-0 | U-0 | U-0 | U-0 | U-0 | U-0 |
| | — | — | — | — | — | — | — | — |
| 23:16 | U-0 | U-0 | U-0 | U-0 | U-0 | U-0 | U-0 | U-0 |
| | — | — | — | — | — | — | — | — |
| 15:8 | U-0 | U-0 | U-0 | R/W-0 | R/W-0 | R/W-0 | R/W-0 | R/W-0 |
| | — | — | — | TXINTTHR<4:0> | | | | |
| 7:0 | U-0 | U-0 | U-0 | R/W-0 | R/W-0 | R/W-0 | R/W-0 | R/W-0 |
| | — | — | — | RXINTTHR<4:0> | | | | |

Legend:

R = Readable bit

W = Writable bit

U = Unimplemented bit, read as '0'

-n = Value at POR

'1' = Bit is set

'0' = Bit is cleared

x = Bit is unknown

bit 31-13 **Unimplemented:** Read as '0'

bit 12-8 **TXINTTHR<4:0>:** Transmit Interrupt Threshold bits

A transmit interrupt is set when the transmit FIFO has more space than the set number of bytes. For 16-bit mode, the value should be a multiple of 2.

bit 7-5 **Unimplemented:** Read as '0'

bit 4-0 **RXINTTHR<4:0>:** Receive Interrupt Threshold bits

A receive interrupt is set when the receive FIFO count is larger than or equal to the set number of bytes. For 16-bit mode, the value should be multiple of 2.

PIC32MZ Embedded Connectivity with Floating Point Unit (EF) Family

REGISTER 20-8: SQI1INTEN: SQI INTERRUPT ENABLE REGISTER

| Bit Range | Bit 31/23/15/7 | Bit 30/22/14/6 | Bit 29/21/13/5 | Bit 28/20/12/4 | Bit 27/19/11/3 | Bit 26/18/10/2 | Bit 25/17/9/1 | Bit 24/16/8/0 |
|-----------|----------------|----------------|----------------|----------------|----------------|----------------|---------------|---------------|
| 31:24 | U-0 | U-0 | U-0 | U-0 | U-0 | U-0 | U-0 | U-0 |
| | — | — | — | — | — | — | — | — |
| 23:16 | U-0 | U-0 | U-0 | U-0 | U-0 | U-0 | U-0 | U-0 |
| | — | — | — | — | — | — | — | — |
| 15:8 | U-0 | U-0 | U-0 | U-0 | R/W-0 | R/W-0 | R/W-0 | R/W-0 |
| | — | — | — | — | DMAEIE | PKTCOMPIE | BDDONEIE | CONTHRIE |
| 7:0 | R/W-0 | R/W-0 | R/W-0 | R/W-0 | R/W-0 | R/W-0 | R/W-0 | R/W-0 |
| | CONEMPTYIE | CONFULLIE | RXTHRIE | RXFULLIE | RXEMPTYIE | TXTHRIE | TXFULLIE | TXEMPTYIE |

| | |
|-------------------|--|
| Legend: | HS = Hardware Set |
| R = Readable bit | W = Writable bit U = Unimplemented bit, read as '0' |
| -n = Value at POR | '1' = Bit is set '0' = Bit is cleared x = Bit is unknown |

- bit 31-12 **Unimplemented:** Read as '0'
- bit 11 **DMAEIE:** DMA Bus Error Interrupt Enable bit
 - 1 = Interrupt is enabled
 - 0 = Interrupt is disabled
- bit 10 **PKTCOMPIE:** DMA Buffer Descriptor Packet Complete Interrupt Enable bit
 - 1 = Interrupt is enabled
 - 0 = Interrupt is disabled
- bit 9 **BDDONEIE:** DMA Buffer Descriptor Done Interrupt Enable bit
 - 1 = Interrupt is enabled
 - 0 = Interrupt is disabled
- bit 8 **CONTHRIE:** Control Buffer Threshold Interrupt Enable bit
 - 1 = Interrupt is enabled
 - 0 = Interrupt is disabled
- bit 7 **CONEMPTYIE:** Control Buffer Empty Interrupt Enable bit
 - 1 = Interrupt is enabled
 - 0 = Interrupt is disabled
- bit 6 **CONFULLIE:** Control Buffer Full Interrupt Enable bit
 - This bit enables an interrupt when the receive FIFO buffer is full.
 - 1 = Interrupt is enabled
 - 0 = Interrupt is disabled
- bit 5 **RXTHRIE:** Receive Buffer Threshold Interrupt Enable bit
 - 1 = Interrupt is enabled
 - 0 = Interrupt is disabled
- bit 4 **RXFULLIE:** Receive Buffer Full Interrupt Enable bit
 - 1 = Interrupt is enabled
 - 0 = Interrupt is disabled
- bit 3 **RXEMPTYIE:** Receive Buffer Empty Interrupt Enable bit
 - 1 = Interrupt is enabled
 - 0 = Interrupt is disabled
- bit 2 **TXTHRIE:** Transmit Threshold Interrupt Enable bit
 - 1 = Interrupt is enabled
 - 0 = Interrupt is disabled
- bit 1 **TXFULLIE:** Transmit Buffer Full Interrupt Enable bit
 - 1 = Interrupt is enabled
 - 0 = Interrupt is disabled
- bit 0 **TXEMPTYIE:** Transmit Buffer Empty Interrupt Enable bit
 - 1 = Interrupt is enabled
 - 0 = Interrupt is disabled

PIC32MZ Embedded Connectivity with Floating Point Unit (EF) Family

REGISTER 20-9: SQI1INTSTAT: SQI INTERRUPT STATUS REGISTER

| Bit Range | Bit 31/23/15/7 | Bit 30/22/14/6 | Bit 29/21/13/5 | Bit 28/20/12/4 | Bit 27/19/11/3 | Bit 26/18/10/2 | Bit 25/17/9/1 | Bit 24/16/8/0 |
|-----------|----------------|----------------|------------------------|----------------|----------------|----------------|---------------|---------------|
| 31:24 | U-0 | U-0 | U-0 | U-0 | U-0 | U-0 | U-0 | U-0 |
| | — | — | — | — | — | — | — | — |
| 23:16 | U-0 | U-0 | U-0 | U-0 | U-0 | U-0 | U-0 | U-0 |
| | — | — | — | — | — | — | — | — |
| 15:8 | U-0 | U-0 | U-0 | U-0 | R/W-0, HS | R/W-0, HS | R/W-0, HS | R/W-0, HS |
| | — | — | — | — | DMA EIF | PKT COMPIF | BD DONEIF | CON THRIF |
| 7:0 | R/W-1, HS | R/W-0, HS | R/W-1, HS | R/W-0, HS | R/W-1, HS | R/W-1, HS | R/W-0, HS | R/W-1, HS |
| | CON EMPTYIF | CON FULLIF | RXTHRIF ⁽¹⁾ | RXFULLIF | RX EMPTYIF | TXTHRIF | TXFULLIF | TX EMPTYIF |

| | |
|-------------------|------------------------------------|
| Legend: | HS = Hardware Set |
| R = Readable bit | W = Writable bit |
| -n = Value at POR | U = Unimplemented bit, read as '0' |
| | '1' = Bit is set |
| | '0' = Bit is cleared |
| | x = Bit is unknown |

bit 31-12 **Unimplemented:** Read as '0'

bit 11 **DMAEIF:** DMA Bus Error Interrupt Flag bit

- 1 = DMA bus error has occurred
- 0 = DMA bus error has not occurred

bit 10 **PKTCOMPIF:** DMA Buffer Descriptor Processor Packet Completion Interrupt Flag bit

- 1 = DMA BD packet is complete
- 0 = DMA BD packet is in progress

bit 9 **BDDONEIF:** DMA Buffer Descriptor Done Interrupt Flag bit

- 1 = DMA BD process is done
- 0 = DMA BD process is in progress

bit 8 **CONTHRIF:** Control Buffer Threshold Interrupt Flag bit

- 1 = The control buffer has more than THRES words of space available
- 0 = The control buffer has less than THRES words of space available

bit 7 **CONEMPTYIF:** Control Buffer Empty Interrupt Flag bit

- 1 = Control buffer is empty
- 0 = Control buffer is not empty

bit 6 **CONFULLIF:** Control Buffer Full Interrupt Flag bit

- 1 = Control buffer is full
- 0 = Control buffer is not full

bit 5 **RXTHRIF:** Receive Buffer Threshold Interrupt Flag bit⁽¹⁾

- 1 = Receive buffer has more than RXINTTHR words of space available
- 0 = Receive buffer has less than RXINTTHR words of space available

bit 4 **RXFULLIF:** Receive Buffer Full Interrupt Flag bit

- 1 = Receive buffer is full
- 0 = Receive buffer is not full

bit 3 **RXEMPTYIF:** Receive Buffer Empty Interrupt Flag bit

- 1 = Receive buffer is empty
- 0 = Receive buffer is not empty

Note 1: In the case of Boot/XIP mode, the POR value of the receive buffer threshold is zero. Therefore, this bit will be set to a '1', immediately after a POR until a read request on the System Bus bus is received.

Note: The bits in the register are cleared by writing a '1' to the corresponding bit position.

PIC32MZ Embedded Connectivity with Floating Point Unit (EF) Family

REGISTER 20-9: SQI1INTSTAT: SQI INTERRUPT STATUS REGISTER (CONTINUED)

- bit 2 **TXTHRIF:** Transmit Buffer Threshold Interrupt Flag bit
 1 = Transmit buffer has more than TXINTTHR words of space available
 0 = Transmit buffer has less than TXINTTHR words of space available
- bit 1 **TXFULLIF:** Transmit Buffer Full Interrupt Flag bit
 1 = The transmit buffer is full
 0 = The transmit buffer is not full
- bit 0 **TXEMPTYIF:** Transmit Buffer Empty Interrupt Flag bit
 1 = The transmit buffer is empty
 0 = The transmit buffer has content

Note 1: In the case of Boot/XIP mode, the POR value of the receive buffer threshold is zero. Therefore, this bit will be set to a '1', immediately after a POR until a read request on the System Bus bus is received.

| |
|---|
| Note: The bits in the register are cleared by writing a '1' to the corresponding bit position. |
|---|

PIC32MZ Embedded Connectivity with Floating Point Unit (EF) Family

REGISTER 20-10: SQI1TXDATA: SQI TRANSMIT DATA BUFFER REGISTER

| Bit Range | Bit 31/23/15/7 | Bit 30/22/14/6 | Bit 29/21/13/5 | Bit 28/20/12/4 | Bit 27/19/11/3 | Bit 26/18/10/2 | Bit 25/17/9/1 | Bit 24/16/8/0 |
|-----------|----------------|----------------|----------------|----------------|----------------|----------------|---------------|---------------|
| 31:24 | R/W-0 | R/W-0 | R/W-0 | R/W-0 | R/W-0 | R/W-0 | R/W-0 | R/W-0 |
| | TXDATA<31:24> | | | | | | | |
| 23:16 | R/W-0 | R/W-0 | R/W-0 | R/W-0 | R/W-0 | R/W-0 | R/W-0 | R/W-0 |
| | TXDATA<23:16> | | | | | | | |
| 15:8 | R/W-0 | R/W-0 | R/W-0 | R/W-0 | R/W-0 | R/W-0 | R/W-0 | R/W-0 |
| | TXDATA<15:8> | | | | | | | |
| 7:0 | R/W-0 | R/W-0 | R/W-0 | R/W-0 | R/W-0 | R/W-0 | R/W-0 | R/W-0 |
| | TXDATA<7:0> | | | | | | | |

Legend:

R = Readable bit
-n = Value at POR

W = Writable bit
'1' = Bit is set

U = Unimplemented bit, read as '0'
'0' = Bit is cleared
x = Bit is unknown

bit 31-0 **TXDATA<31:0>**: Transmit Command Data bits

Data is loaded into this register before being transmitted. Just prior to the beginning of a data transfer, the data in TXDATA is loaded into the shift register (SFDR).

Multiple writes to TXDATA can occur even while a transfer is already in progress. There can be a maximum of eight commands that can be queued.

REGISTER 20-11: SQI1RXDATA: SQI RECEIVE DATA BUFFER REGISTER

| Bit Range | Bit 31/23/15/7 | Bit 30/22/14/6 | Bit 29/21/13/5 | Bit 28/20/12/4 | Bit 27/19/11/3 | Bit 26/18/10/2 | Bit 25/17/9/1 | Bit 24/16/8/0 |
|-----------|----------------|----------------|----------------|----------------|----------------|----------------|---------------|---------------|
| 31:24 | R-0 | R-0 | R-0 | R-0 | R-0 | R-0 | R-0 | R-0 |
| | RXDATA<31:24> | | | | | | | |
| 23:16 | R-0 | R-0 | R-0 | R-0 | R-0 | R-0 | R-0 | R-0 |
| | RXDATA<23:16> | | | | | | | |
| 15:8 | R-0 | R-0 | R-0 | R-0 | R-0 | R-0 | R-0 | R-0 |
| | RXDATA<15:8> | | | | | | | |
| 7:0 | R-0 | R-0 | R-0 | R-0 | R-0 | R-0 | R-0 | R-0 |
| | RXDATA<7:0> | | | | | | | |

Legend:

R = Readable bit
-n = Value at POR

W = Writable bit
'1' = Bit is set

U = Unimplemented bit, read as '0'
'0' = Bit is cleared
x = Bit is unknown

bit 31-0 **RXDATA<31:0>**: Receive Data Buffer bits

At the end of a data transfer, the data in the shift register is loaded into the RXDATA register. This register works like a FIFO. The depth of the receive buffer is eight words.

PIC32MZ Embedded Connectivity with Floating Point Unit (EF) Family

REGISTER 20-12: SQI1STAT1: SQI STATUS REGISTER 1

| Bit Range | Bit 31/23/15/7 | Bit 30/22/14/6 | Bit 29/21/13/5 | Bit 28/20/12/4 | Bit 27/19/11/3 | Bit 26/18/10/2 | Bit 25/17/9/1 | Bit 24/16/8/0 |
|-----------|-----------------|----------------|----------------|----------------|----------------|----------------|---------------|---------------|
| 31:24 | U-0 | U-0 | U-0 | U-0 | U-0 | U-0 | U-0 | U-0 |
| | — | — | — | — | — | — | — | — |
| 23:16 | R-0 | R-0 | R-0 | R-0 | R-0 | R-0 | R-0 | R-0 |
| | TXFIFOFREE<7:0> | | | | | | | |
| 15:8 | U-0 | U-0 | U-0 | U-0 | U-0 | U-0 | U-0 | U-0 |
| | — | — | — | — | — | — | — | — |
| 7:0 | R-0 | R-0 | R-0 | R-0 | R-0 | R-0 | R-0 | R-0 |
| | RXFIFOCNT<7:0> | | | | | | | |

Legend:

R = Readable bit

W = Writable bit

U = Unimplemented bit, read as '0'

-n = Value at POR

'1' = Bit is set

'0' = Bit is cleared

x = Bit is unknown

bit 31-24 **Unimplemented:** Read as '0'

bit 23-16 **TXFIFOFREE<7:0>:** Transmit FIFO Available Word Space bits

bit 15-8 **Unimplemented:** Read as '0'

bit 7-0 **RXFIFOCNT<7:0>:** Number of words of read data in the FIFO

PIC32MZ Embedded Connectivity with Floating Point Unit (EF) Family

REGISTER 20-13: SQI1STAT2: SQI STATUS REGISTER 2

| Bit Range | Bit 31/23/15/7 | Bit 30/22/14/6 | Bit 29/21/13/5 | Bit 28/20/12/4 | Bit 27/19/11/3 | Bit 26/18/10/2 | Bit 25/17/9/1 | Bit 24/16/8/0 |
|-----------|--------------------|----------------|----------------|----------------|----------------|----------------------|---------------------|---------------|
| 31:24 | U-0 — | U-0 — | U-0 — | U-0 — | U-0 — | U-0 — | U-0 — | U-0 — |
| 23:16 | U-0 — | U-0 — | U-0 — | U-0 — | U-0 — | U-0 — | R-0 CMDSTAT<1:0> | R-0 — |
| 15:8 | U-0 — | U-0 — | U-0 — | U-0 — | R-0 — | R-0 CONAVAIL<4:1> | R-0 — | R-0 — |
| 7:0 | R-0 CONAVAIL<0> | R-0 SQID3 | R-0 SQID2 | R-0 SQID1 | R-0 SQID0 | U-0 — | R-0 RXUN | R-0 TXOV |

Legend:

R = Readable bit
-n = Value at POR

W = Writable bit
'1' = Bit is set

U = Unimplemented bit, read as '0'
'0' = Bit is cleared
x = Bit is unknown

bit 31-18 **Unimplemented:** Read as '0'

bit 17-16 **CMDSTAT<1:0>**: Current Command Status bits

These bits indicate the current command status.

11 = Reserved

10 = Receive

01 = Transmit

00 = Idle

bit 15-12 **Unimplemented:** Read as '0'

bit 11-7 **CONAVAIL<4:0>**: Control FIFO Space Available bits

These bits indicate the available control Word space.

11111 = 32 bytes are available

11110 = 31 bytes are available

•

•

•

00001 = 1 byte is available

00000 = No bytes are available

bit 6 **SQID3**: SQID3 Status bit

1 = Data is present on SQID3

0 = Data is not present on SQID3

bit 5 **SQID2**: SQID2 Status bit

1 = Data is present on SQID2

0 = Data is not present on SQID2

bit 4 **SQID1**: SQID1 Status bit

1 = Data is present on SQID1

0 = Data is not present on SQID1

bit 3 **SQID0**: SQID0 Status bit

1 = Data is present on SQID0

0 = Data is not present on SQID0

bit 2 **Unimplemented:** Read as '0'

bit 1 **RXUN**: Receive FIFO Underflow Status bit

1 = Receive FIFO Underflow has occurred

0 = Receive FIFO underflow has not occurred

bit 0 **TXOV**: Transmit FIFO Overflow Status bit

1 = Transmit FIFO overflow has occurred

0 = Transmit FIFO overflow has not occurred

PIC32MZ Embedded Connectivity with Floating Point Unit (EF) Family

REGISTER 20-14: SQI1BDCON: SQI BUFFER DESCRIPTOR CONTROL REGISTER

| Bit Range | Bit 31/23/15/7 | Bit 30/22/14/6 | Bit 29/21/13/5 | Bit 28/20/12/4 | Bit 27/19/11/3 | Bit 26/18/10/2 | Bit 25/17/9/1 | Bit 24/16/8/0 |
|-----------|----------------|----------------|----------------|----------------|----------------|----------------|---------------|---------------|
| 31:24 | U-0 | U-0 | U-0 | U-0 | U-0 | U-0 | U-0 | U-0 |
| | — | — | — | — | — | — | — | — |
| 23:16 | U-0 | U-0 | U-0 | U-0 | U-0 | U-0 | U-0 | U-0 |
| | — | — | — | — | — | — | — | — |
| 15:8 | U-0 | U-0 | U-0 | U-0 | U-0 | U-0 | U-0 | U-0 |
| | — | — | — | — | — | — | — | — |
| 7:0 | U-0 | U-0 | U-0 | U-0 | U-0 | R/W-0 | R/W-0 | R/W-0 |
| | — | — | — | — | — | START | POLLEN | DMAEN |

Legend:

R = Readable bit
-n = Value at POR

W = Writable bit
'1' = Bit is set

U = Unimplemented bit, read as '0'
'0' = Bit is cleared
x = Bit is unknown

- bit 31-3 **Unimplemented:** Read as '0'
- bit 2 **START:** Buffer Descriptor Processor Start bit
 - 1 = Start the buffer descriptor processor
 - 0 = Disable the buffer descriptor processor
- bit 1 **POLLEN:** Buffer Descriptor Poll Enable bit
 - 1 = BDP poll is enabled
 - 0 = BDP poll is not enabled
- bit 0 **DMAEN:** DMA Enable bit
 - 1 = DMA is enabled
 - 0 = DMA is disabled

REGISTER 20-15: SQI1BDCURADD: SQI BUFFER DESCRIPTOR CURRENT ADDRESS REGISTER

| Bit Range | Bit 31/23/15/7 | Bit 30/22/14/6 | Bit 29/21/13/5 | Bit 28/20/12/4 | Bit 27/19/11/3 | Bit 26/18/10/2 | Bit 25/17/9/1 | Bit 24/16/8/0 |
|-----------|-------------------|----------------|----------------|----------------|----------------|----------------|---------------|---------------|
| 31:24 | R-0 | R-0 | R-0 | R-0 | R-0 | R-0 | R-0 | R-0 |
| | BDCURRADDR<31:24> | | | | | | | |
| 23:16 | R-0 | R-0 | R-0 | R-0 | R-0 | R-0 | R-0 | R-0 |
| | BDCURRADDR<23:16> | | | | | | | |
| 15:8 | R-0 | R-0 | R-0 | R-0 | R-0 | R-0 | R-0 | R-0 |
| | BDCURRADDR<15:8> | | | | | | | |
| 7:0 | R-0 | R-0 | R-0 | R-0 | R-0 | R-0 | R-0 | R-0 |
| | BDCURRADDR<7:0> | | | | | | | |

Legend:

R = Readable bit
-n = Value at POR

W = Writable bit
'1' = Bit is set

U = Unimplemented bit, read as '0'
'0' = Bit is cleared
x = Bit is unknown

- bit 31-0 **BDCURRADDR<31:0>:** Current Buffer Descriptor Address bits
These bits contain the address of the current descriptor being processed by the Buffer Descriptor Processor.

PIC32MZ Embedded Connectivity with Floating Point Unit (EF) Family

REGISTER 20-16: SQI1BDBASEADD: SQI BUFFER DESCRIPTOR BASE ADDRESS REGISTER

| Bit Range | Bit 31/23/15/7 | Bit 30/22/14/6 | Bit 29/21/13/5 | Bit 28/20/12/4 | Bit 27/19/11/3 | Bit 26/18/10/2 | Bit 25/17/9/1 | Bit 24/16/8/0 |
|---------------|----------------|----------------|----------------|----------------|----------------|----------------|---------------|---------------|
| 31:24 | R/W-0 | R/W-0 | R/W-0 | R/W-0 | R/W-0 | R/W-0 | R/W-0 | R/W-0 |
| BDADDR<31:24> | | | | | | | | |
| 23:16 | R/W-0 | R/W-0 | R/W-0 | R/W-0 | R/W-0 | R/W-0 | R/W-0 | R/W-0 |
| BDADDR<23:16> | | | | | | | | |
| 15:8 | R/W-0 | R/W-0 | R/W-0 | R/W-0 | R/W-0 | R/W-0 | R/W-0 | R/W-0 |
| BDADDR<15:8> | | | | | | | | |
| 7:0 | R/W-0 | R/W-0 | R/W-0 | R/W-0 | R/W-0 | R/W-0 | R/W-0 | R/W-0 |
| BDADDR<7:0> | | | | | | | | |

Legend:

R = Readable bit
 -n = Value at POR
 W = Writable bit
 '1' = Bit is set
 U = Unimplemented bit, read as '0'
 '0' = Bit is cleared
 x = Bit is unknown

bit 31-0 **BDADDR<31:0>**: DMA Base Address bits
 These bits contain the physical address of the root buffer descriptor. This register should be updated only when the DMA is idle.

REGISTER 20-17: SQI1BDSTAT: SQI BUFFER DESCRIPTOR STATUS REGISTER

| Bit Range | Bit 31/23/15/7 | Bit 30/22/14/6 | Bit 29/21/13/5 | Bit 28/20/12/4 | Bit 27/19/11/3 | Bit 26/18/10/2 | Bit 25/17/9/1 | Bit 24/16/8/0 |
|--------------|----------------|----------------|----------------|----------------|----------------|----------------|---------------|---------------|
| 31:24 | U-0 | U-0 | U-0 | U-0 | U-0 | U-0 | U-0 | U-0 |
| BDSTATE<3:0> | | | | | | | | |
| 23:16 | U-0 | U-0 | R-x | R-x | R-x | R-x | R-x | R-x |
| | | | | | | DMASTART | DMAACTV | |
| 15:8 | R-x | R-x | R-x | R-x | R-x | R-x | R-x | R-x |
| BDCON<15:8> | | | | | | | | |
| 7:0 | R-x | R-x | R-x | R-x | R-x | R-x | R-x | R-x |
| BDCON<7:0> | | | | | | | | |

Legend:

R = Readable bit
 -n = Value at POR
 W = Writable bit
 '1' = Bit is set
 U = Unimplemented bit, read as '0'
 '0' = Bit is cleared
 x = Bit is unknown

bit 31-22 **Unimplemented**: Read as '0'

bit 21-18 **BDSTATE<3:0>**: DMA Buffer Descriptor Processor State Status bits
 These bits return the current state of the buffer descriptor processor:
 5 = Fetched buffer descriptor is disabled
 4 = Descriptor is done
 3 = Data phase
 2 = Buffer descriptor is loading
 1 = Descriptor fetch request is pending
 0 = Idle

bit 17 **DMASTART**: DMA Buffer Descriptor Processor Start Status bit
 1 = DMA has started
 0 = DMA has not started

bit 16 **DMAACTV**: DMA Buffer Descriptor Processor Active Status bit
 1 = Buffer Descriptor Processor is active
 0 = Buffer Descriptor Processor is idle

bit 15-0 **BDCON<15:0>**: DMA Buffer Descriptor Control Word bits
 These bits contain the current buffer descriptor control word.

PIC32MZ Embedded Connectivity with Floating Point Unit (EF) Family

REGISTER 20-18: SQI1BDPOLLCON: SQI BUFFER DESCRIPTOR POLL CONTROL REGISTER

| Bit Range | Bit 31/23/15/7 | Bit 30/22/14/6 | Bit 29/21/13/5 | Bit 28/20/12/4 | Bit 27/19/11/3 | Bit 26/18/10/2 | Bit 25/17/9/1 | Bit 24/16/8/0 |
|-----------|----------------|----------------|----------------|----------------|----------------|----------------|---------------|---------------|
| 31:24 | U-0 | U-0 | U-0 | U-0 | U-0 | U-0 | U-0 | U-0 |
| | — | — | — | — | — | — | — | — |
| 23:16 | U-0 | U-0 | U-0 | U-0 | U-0 | U-0 | U-0 | U-0 |
| | — | — | — | — | — | — | — | — |
| 15:8 | R/W-0 | R/W-0 | R/W-0 | R/W-0 | R/W-0 | R/W-0 | R/W-0 | R/W-0 |
| | POLLCON<15:8> | | | | | | | |
| 7:0 | R/W-0 | R/W-0 | R/W-0 | R/W-0 | R/W-0 | R/W-0 | R/W-0 | R/W-0 |
| | POLLCON<7:0> | | | | | | | |

Legend:

R = Readable bit
-n = Value at POR

W = Writable bit
'1' = Bit is set

U = Unimplemented bit, read as '0'
'0' = Bit is cleared
x = Bit is unknown

bit 31-16 **Unimplemented:** Read as '0'

bit 15-0 **POLLCON<15:0>:** Buffer Descriptor Processor Poll Status bits

These bits indicate the number of cycles the BDP would wait before refetching the descriptor control word if the previous descriptor fetched was disabled.

REGISTER 20-19: SQI1BDTXDSTAT: SQI BUFFER DESCRIPTOR DMA TRANSMIT STATUS REGISTER

| Bit Range | Bit 31/23/15/7 | Bit 30/22/14/6 | Bit 29/21/13/5 | Bit 28/20/12/4 | Bit 27/19/11/3 | Bit 26/18/10/2 | Bit 25/17/9/1 | Bit 24/16/8/0 |
|-----------|-----------------|----------------|----------------|----------------|----------------|----------------|---------------|---------------|
| 31:24 | U-0 | U-0 | U-0 | R-x | R-x | R-x | R-x | U-0 |
| | — | — | — | TXSTATE<3:0> | | | | — |
| 23:16 | U-0 | U-0 | U-0 | R-x | R-x | R-x | R-x | R-x |
| | — | — | — | TXBUFCNT<4:0> | | | | — |
| 15:8 | U-0 | U-0 | U-0 | U-0 | U-0 | U-0 | U-0 | U-0 |
| | — | — | — | — | — | — | — | — |
| 7:0 | R-x | R-x | R-x | R-x | R-x | R-x | R-x | R-x |
| | TXCURBUFLN<7:0> | | | | | | | |

Legend:

R = Readable bit
-n = Value at POR

W = Writable bit
'1' = Bit is set

U = Unimplemented bit, read as '0'
'0' = Bit is cleared
x = Bit is unknown

bit 31-29 **Unimplemented:** Read as '0'

bit 28-25 **TXSTATE<3:0>:** Current DMA Transmit State Status bits

These bits provide information on the current DMA receive states.

bit 24-21 **Unimplemented:** Read as '0'

bit 20-16 **TXBUFCNT<4:0>:** DMA Buffer Byte Count Status bits

These bits provide information on the internal FIFO space.

bit 15-8 **Unimplemented:** Read as '0'

bit 7-0 **TXCURBUFLN<7:0>:** Current DMA Transmit Buffer Length Status bits

These bits provide the length of the current DMA transmit buffer.

PIC32MZ Embedded Connectivity with Floating Point Unit (EF) Family

REGISTER 20-20: SQI1BDRXDSTAT: SQI BUFFER DESCRIPTOR DMA RECEIVE STATUS REGISTER

| Bit Range | Bit 31/23/15/7 | Bit 30/22/14/6 | Bit 29/21/13/5 | Bit 28/20/12/4 | Bit 27/19/11/3 | Bit 26/18/10/2 | Bit 25/17/9/1 | Bit 24/16/8/0 |
|-----------|------------------|----------------|----------------|----------------|----------------|----------------|---------------|---------------|
| 31:24 | U-0 | U-0 | U-0 | R-x | R-x | R-x | R-x | U-0 |
| | — | — | — | RXSTATE<3:0> | | | | — |
| 23:16 | U-0 | U-0 | U-0 | R-x | R-x | R-x | R-x | R-x |
| | — | — | — | RXBUFCNT<4:0> | | | | — |
| 15:8 | U-0 | U-0 | U-0 | U-0 | U-0 | U-0 | U-0 | U-0 |
| | — | — | — | — | — | — | — | — |
| 7:0 | R-x | R-x | R-x | R-x | R-x | R-x | R-x | R-x |
| | RXCURBUFLEN<7:0> | | | | | | | |

Legend:

R = Readable bit
-n = Value at POR

W = Writable bit
'1' = Bit is set

U = Unimplemented bit, read as '0'
'0' = Bit is cleared
x = Bit is unknown

bit 31-29 **Unimplemented:** Read as '0'

bit 28-25 **RXSTATE<3:0>**: Current DMA Receive State Status bits
These bits provide information on the current DMA receive states.

bit 24-21 **Unimplemented:** Read as '0'

bit 20-16 **RXBUFCNT<4:0>**: DMA Buffer Byte Count Status bits
These bits provide information on the internal FIFO space.

bit 15-8 **Unimplemented:** Read as '0'

bit 7-0 **RXCURBUFLEN<7:0>**: Current DMA Receive Buffer Length Status bits
These bits provide the length of the current DMA receive buffer.

REGISTER 20-21: SQI1THR: SQI THRESHOLD CONTROL REGISTER

| Bit Range | Bit 31/23/15/7 | Bit 30/22/14/6 | Bit 29/21/13/5 | Bit 28/20/12/4 | Bit 27/19/11/3 | Bit 26/18/10/2 | Bit 25/17/9/1 | Bit 24/16/8/0 |
|-----------|----------------|----------------|----------------|----------------|----------------|----------------|---------------|---------------|
| 31:24 | U-0 | U-0 | U-0 | U-0 | U-0 | U-0 | U-0 | U-0 |
| | — | — | — | — | — | — | — | — |
| 23:16 | U-0 | U-0 | U-0 | U-0 | U-0 | U-0 | U-0 | U-0 |
| | — | — | — | — | — | — | — | — |
| 15:8 | U-0 | U-0 | U-0 | U-0 | U-0 | U-0 | U-0 | U-0 |
| | — | — | — | — | — | — | — | — |
| 7:0 | U-0 | R/W-0 | R/W-0 | R/W-0 | R/W-0 | R/W-0 | R/W-0 | R/W-0 |
| | — | THRES<6:0> | | | | | | |

Legend:

R = Readable bit
-n = Value at POR

W = Writable bit
'1' = Bit is set

U = Unimplemented bit, read as '0'
'0' = Bit is cleared
x = Bit is unknown

bit 31-7 **Unimplemented:** Read as '0'

bit 6-0 **THRES<6:0>**: SQI Control Threshold Value bits
The SQI control threshold interrupt is asserted when the amount of space indicated by THRES<6:0> is available in the SQI control buffer.

PIC32MZ Embedded Connectivity with Floating Point Unit (EF) Family

REGISTER 20-22: SQI1INTSIGEN: SQI INTERRUPT SIGNAL ENABLE REGISTER

| Bit Range | Bit 31/23/15/7 | Bit 30/22/14/6 | Bit 29/21/13/5 | Bit 28/20/12/4 | Bit 27/19/11/3 | Bit 26/18/10/2 | Bit 25/17/9/1 | Bit 24/16/8/0 |
|-----------|--------------------------|-------------------------|-----------------------|------------------------|-------------------------|-------------------------|------------------------|-------------------------|
| 31:24 | U-0 — | U-0 — | U-0 — | U-0 — | U-0 — | U-0 — | U-0 — | U-0 — |
| 23:16 | U-0 — | U-0 — | U-0 — | U-0 — | U-0 — | U-0 — | U-0 — | U-0 — |
| 15:8 | U-0 — | U-0 — | U-0 — | U-0 — | R/W-0 DMAEISE | R/W-0 PKT DONEISE | R/W-0 BD DONEISE | R/W-0 CON THRISE |
| | R/W-0 CON EMPTYISE | R/W-0 CON FULLISE | R/W-0 RX THRISE | R/W-0 RX FULLISE | R/W-0 RX EMPTYISE | R/W-0 TX THRISE | R/W-0 TX FULLISE | R/W-0 TX EMPTYISE |

Legend:

| | | |
|-------------------|------------------|------------------------------------|
| R = Readable bit | W = Writable bit | U = Unimplemented bit, read as '0' |
| -n = Value at POR | '1' = Bit is set | '0' = Bit is cleared |
| | | x = Bit is unknown |

- bit 31-12 **Unimplemented:** Read as '0'
- bit 11 **DMAEISE:** DMA Bus Error Interrupt Signal Enable bit
 - 1 = Interrupt signal is enabled
 - 0 = Interrupt signal is disabled
- bit 10 **PKTDONEISE:** Receive Error Interrupt Signal Enable bit
 - 1 = Interrupt signal is enabled
 - 0 = Interrupt signal is disabled
- bit 9 **BDDONEISE:** Transmit Error Interrupt Signal Enable bit
 - 1 = Interrupt signal is enabled
 - 0 = Interrupt signal is disabled
- bit 8 **CONTHRISE:** Control Buffer Threshold Interrupt Signal Enable bit
 - 1 = Interrupt signal is enabled
 - 0 = Interrupt signal is disabled
- bit 7 **CONEMPTYISE:** Control Buffer Empty Interrupt Signal Enable bit
 - 1 = Interrupt signal is enabled
 - 0 = Interrupt signal is disabled
- bit 6 **CONFULLISE:** Control Buffer Full Interrupt Signal Enable bit
 - 1 = Interrupt signal is enabled
 - 0 = Interrupt signal is disabled
- bit 5 **RXTHRISE:** Receive Buffer Threshold Interrupt Signal Enable bit
 - 1 = Interrupt signal is enabled
 - 0 = Interrupt signal is disabled
- bit 4 **RXFULLISE:** Receive Buffer Full Interrupt Signal Enable bit
 - 1 = Interrupt signal is enabled
 - 0 = Interrupt signal is disabled
- bit 3 **RXEMPTYISE:** Receive Buffer Empty Interrupt Signal Enable bit
 - 1 = Interrupt signal is enabled
 - 0 = Interrupt signal is disabled
- bit 2 **TXTHRISE:** Transmit Buffer Threshold Interrupt Signal Enable bit
 - 1 = Interrupt signal is enabled
 - 0 = Interrupt signal is disabled
- bit 1 **TXFULLISE:** Transmit Buffer Full Interrupt Signal Enable bit
 - 1 = Interrupt signal is enabled
 - 0 = Interrupt signal is disabled
- bit 0 **TXEMPTYISE:** Transmit Buffer Empty Interrupt Signal Enable bit
 - 1 = Interrupt signal is enabled
 - 0 = Interrupt signal is disabled

PIC32MZ Embedded Connectivity with Floating Point Unit (EF) Family

REGISTER 20-23: SQI1TAPCON: SQI TAP CONTROL REGISTER

| Bit Range | Bit 31/23/15/7 | Bit 30/22/14/6 | Bit 29/21/13/5 | Bit 28/20/12/4 | Bit 27/19/11/3 | Bit 26/18/10/2 | Bit 25/17/9/1 | Bit 24/16/8/0 |
|-----------|-----------------|----------------|----------------|----------------|----------------|----------------|---------------|---------------|
| 31:24 | U-0 | U-0 | U-0 | U-0 | U-0 | U-0 | U-0 | U-0 |
| | — | — | — | — | — | — | — | — |
| 23:16 | U-0 | U-0 | U-0 | U-0 | U-0 | U-0 | U-0 | U-0 |
| | — | — | — | — | — | — | — | — |
| 15:8 | U-0 | U-0 | R/W-0 | R/W-0 | R/W-0 | R/W-0 | R/W-0 | R/W-0 |
| | — | — | CLKINDLY<5:0> | | | | | |
| 7:0 | R/W-0 | R/W-0 | R/W-0 | R/W-0 | R/W-0 | R/W-0 | R/W-0 | R/W-0 |
| | DATAOUTDLY<3:0> | | | | CLKOUTDLY<3:0> | | | |

Legend:

R = Readable bit

W = Writable bit

U = Unimplemented bit, read as '0'

-n = Value at POR

'1' = Bit is set

'0' = Bit is cleared

x = Bit is unknown

bit 31-14 **Unimplemented:** Read as '0'

bit 13-8 **CLKINDLY<5:0>:** SQI Clock Input Delay bits

These bits are used to add fractional delays to SQI Clock Input while sampling the incoming data.

111111 = 64 taps added on clock input

111110 = 63 taps added on clock input

-
-
-

000001 = 2 taps added on clock input

000000 = 1 tap added on clock input

bit 7-4 **DATAOUTDLY<3:0>:** SQI Data Output Delay bits

These bits are used to add fractional delays to SQI Data Output while writing the data to the Flash.

1111 = 16 taps added on clock output

1110 = 15 taps added on clock output

-
-
-

0001 = 2 taps added on clock output

0000 = 1 tap added on clock output

bit 3-0 **CLKOUTDLY<3:0>:** SQI Clock Output Delay bits

These bits are used to add fractional delays to SQI Clock Output while writing the data to the Flash.

1111 = 16 taps added on clock output

1110 = 15 taps added on clock output

-
-
-

0001 = 2 taps added on clock output

0000 = 1 tap added on clock output

PIC32MZ Embedded Connectivity with Floating Point Unit (EF) Family

REGISTER 20-24: SQI1MEMSTAT: SQI MEMORY STATUS REGISTER

| Bit Range | Bit 31/23/15/7 | Bit 30/22/14/6 | Bit 29/21/13/5 | Bit 28/20/12/4 | Bit 27/19/11/3 | Bit 26/18/10/2 | Bit 25/17/9/1 | Bit 24/16/8/0 |
|---------------|----------------|----------------|----------------|------------------|------------------------|-------------------------|---------------|---------------|
| 31:24 | U-0 — | U-0 — | U-0 — | U-0 — | U-0 — | U-0 — | U-0 — | U-0 — |
| 23:16 | U-0 — | U-0 — | U-0 — | R/W-0 STATPOS | R/W-0 STATTYPE<1:0> | R/W-0 STATBYTES<1:0> | R/W-0 | R/W-0 |
| 15:8 | R/W-0 | R/W-0 | R/W-0 | R/W-0 | R/W-0 | R/W-0 | R/W-0 | R/W-0 |
| STATDATA<7:0> | | | | | | | | |
| 7:0 | R/W-0 | R/W-0 | R/W-0 | R/W-0 | R/W-0 | R/W-0 | R/W-0 | R/W-0 |
| STATCMD<7:0> | | | | | | | | |

Legend:

R = Readable bit
-n = Value at POR

W = Writable bit
'1' = Bit is set

U = Unimplemented bit, read as '0'
'0' = Bit is cleared
x = Bit is unknown

bit 31-21 **Unimplemented:** Read as '0'

bit 20 **STATPOS:** Status Bit Position in Flash bit

Indicates the BUSY bit position in the Flash Status register. This bit is added to support all Flash types (with BUSY bit at 0 and at 7).

1 = BUSY bit position is bit 7 in status register
0 = BUSY bit position is bit 0 in status register

bit 19-18 **STATTYPE<1:0>:** Status Command/Read Lane Mode bits

11 = Reserved
10 = Status command and read are executed in Quad Lane mode
01 = Status command and read are executed in Dual Lane mode
00 = Status command and read are executed in Single Lane mode

bit 17-16 **STATBYTES<1:0>:** Number of Status Bytes bits

11 = Reserved
10 = Status command/read is 2 bytes long
01 = Status command/read is 1 byte long
00 = Reserved

bit 15-8 **STATDATA<7:0>:** Status Data bits

These bits contain the status value of the Flash device

bit 7-0 **STATCMD<7:0>:** Status Command bits

The status check command is written into these bits

PIC32MZ Embedded Connectivity with Floating Point Unit (EF) Family

REGISTER 20-26: SQI1XCON4: SQI XIP CONTROL REGISTER 4

| Bit Range | Bit 31/23/15/7 | Bit 30/22/14/6 | Bit 29/21/13/5 | Bit 28/20/12/4 | Bit 27/19/11/3 | Bit 26/18/10/2 | Bit 25/17/9/1 | Bit 24/16/8/0 |
|-----------|-------------------------------|----------------|----------------|----------------|-----------------|----------------|----------------|---------------|
| 31:24 | U-0 | U-0 | U-0 | R/W-0 | R/W-0 | R/W-0 | R/W-0 | R/W-0 |
| | — | — | — | INIT2SCHECK | INIT2COUNT<1:0> | | INIT2TYPE<1:0> | |
| 23:16 | R/W-0 | R/W-0 | R/W-0 | R/W-0 | R/W-0 | R/W-0 | R/W-0 | R/W-0 |
| | INIT2CMD3<7:0> ⁽¹⁾ | | | | | | | |
| 15:8 | R/W-0 | R/W-0 | R/W-0 | R/W-0 | R/W-0 | R/W-0 | R/W-0 | R/W-0 |
| | INIT2CMD2<7:0> ⁽¹⁾ | | | | | | | |
| 7:0 | R/W-0 | R/W-0 | R/W-0 | R/W-0 | R/W-0 | R/W-0 | R/W-0 | R/W-0 |
| | INIT2CMD1<7:0> ⁽¹⁾ | | | | | | | |

Legend:

R = Readable bit
-n = Value at POR

W = Writable bit
'1' = Bit is set

U = Unimplemented bit, read as '0'
'0' = Bit is cleared
x = Bit is unknown

bit 31-29 **Unimplemented:** Read as '0'

bit 28 **INIT2SCHECK:** Flash Initialization 2 Command Status Check bit

- 1 = Check the status after executing the INIT2 command
- 0 = Do not check the status

bit 27-26 **INIT2COUNT<1:0>:** Flash Initialization 2 Command Count bits

- 11 = INIT2CMD1, INIT2CMD2, and INIT2CMD3 are sent
- 10 = INIT2CMD1 and INIT2CMD2 are sent, but INIT2CMD3 is still pending
- 01 = INIT2CMD1 is sent, but INIT2CMD2 and INIT2CMD3 are still pending
- 00 = No commands are sent

bit 25-24 **INIT2TYPE<1:0>:** Flash Initialization 2 Command Type bits

- 11 = Reserved
- 10 = INIT2 commands are sent in Quad Lane mode
- 01 = INIT2 commands are sent in Dual Lane mode
- 00 = INIT2 commands are sent in Single Lane mode

bit 24-16 **INIT2CMD3<7:0>:** Flash Initialization Command 3 bits⁽¹⁾

Third command of the Flash initialization.

bit 15-8 **INIT2CMD2<7:0>:** Flash Initialization Command 2 bits⁽¹⁾

Second command of the Flash initialization.

bit 7-0 **INIT2CMD1<7:0>:** Flash Initialization Command 1 bits⁽¹⁾

First command of the Flash initialization.

Note 1: INIT2CMD1 can be WEN and INIT2CMD2 can be SECTOR UNPROTECT.

Note: Some Flash devices require write enable and sector unprotect commands before write/read operations and this register is useful in working with those Flash types (XIP mode only)

PIC32MZ Embedded Connectivity with Floating Point Unit (EF) Family

NOTES:

21.0 INTER-INTEGRATED CIRCUIT™ (I²C™)

Note: This data sheet summarizes the features of the PIC32MZ EF family of devices. It is not intended to be a comprehensive reference source. To complement the information in this data sheet, refer to **Section 24. “Inter-Integrated Circuit™ (I²C™)”** (DS60001116) in the “PIC32 Family Reference Manual”, which is available from the Microchip web site (www.microchip.com/PIC32).

The I²C module provides complete hardware support for both Slave and Multi-Master modes of the I²C serial communication standard.

Each I²C module has a 2-pin interface:

- SCLx pin is clock
- SDAx pin is data

Each I²C module offers the following key features:

- I²C interface supporting both master and slave operation
- I²C Slave mode supports 7-bit and 10-bit addressing
- I²C Master mode supports 7-bit and 10-bit addressing
- I²C port allows bidirectional transfers between master and slaves
- Serial clock synchronization for the I²C port can be used as a handshake mechanism to suspend and resume serial transfer (SCLREL control)
- I²C supports multi-master operation; detects bus collision and arbitrates accordingly
- Provides support for address bit masking
- SMBus support

Figure 21-1 illustrates the I²C module block diagram.

FIGURE 21-1: I²C™ BLOCK DIAGRAM

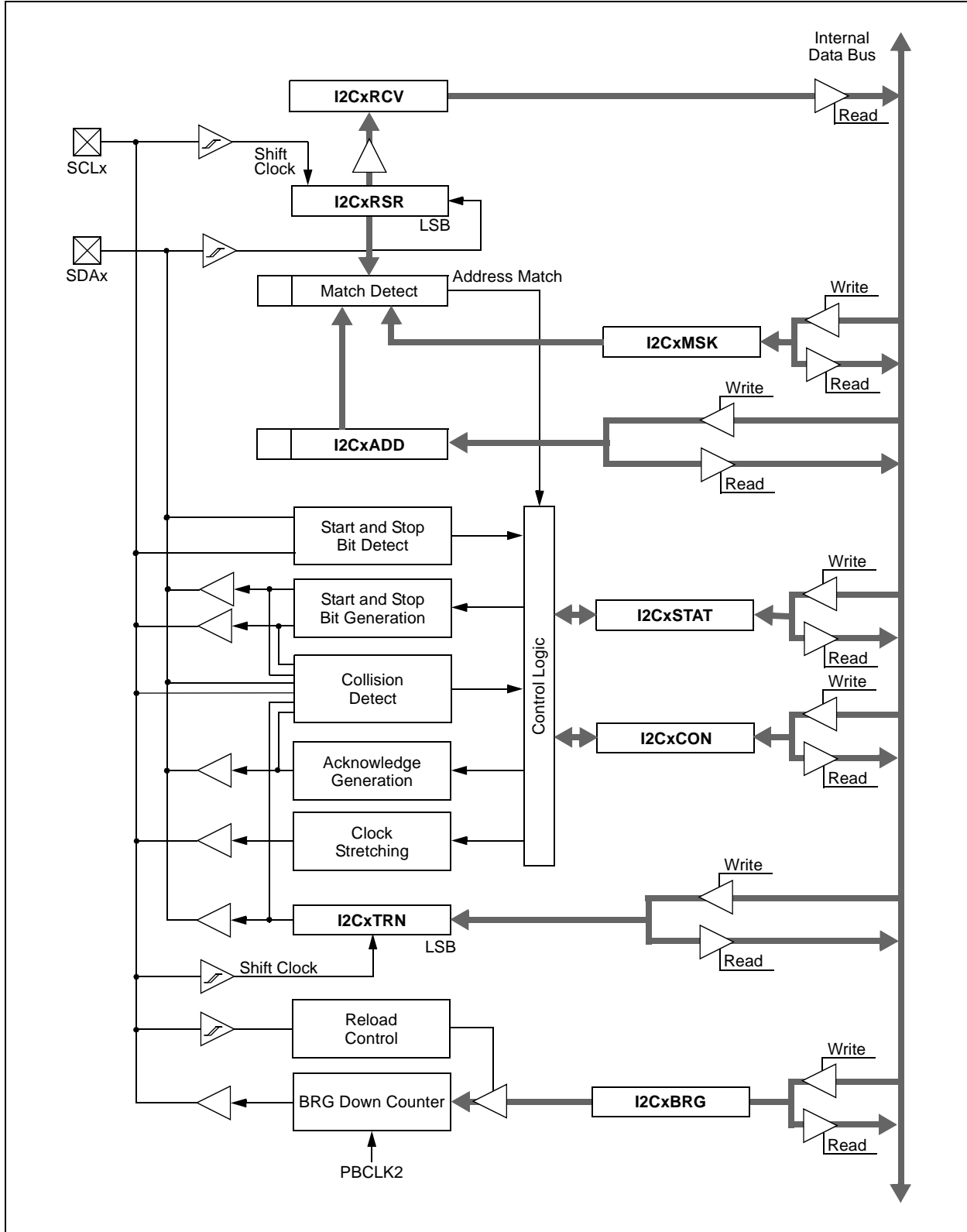

21.1 I²C Control Registers

TABLE 21-1: I2C1 THROUGH I2C5 REGISTER MAP

| Virtual Address (BF82_#) | Register Name ⁽¹⁾ | Bit Range | Bits | | | | | | | | | | | | | | | | All Resets | |
|-----------------------------|---------------------------------|-----------|---------|--------|--------|--------|--------|-------|--------|-------|-------|-------|-------|-------|------|-------|-------|------|------------|------------------------------|
| | | | 31/15 | 30/14 | 29/13 | 28/12 | 27/11 | 26/10 | 25/9 | 24/8 | 23/7 | 22/6 | 21/5 | 20/4 | 19/3 | 18/2 | 17/1 | 16/0 | | |
| 0000 | I2C1CON | 31:16 | — | — | — | — | — | — | — | — | — | — | PCIE | SCIE | BOEN | SDAHT | SBCDE | AHEN | DHEN | 0000 |
| | | 15:0 | ON | — | SIDL | SCLREL | STRICT | A10M | DISSLW | SMEN | GCEN | STREN | ACKDT | ACKEN | RCEN | PEN | RSEN | SEN | 1000 | |
| 0010 | I2C1STAT | 31:16 | — | — | — | — | — | — | — | — | — | — | — | — | — | — | — | — | — | 0000 |
| | | 15:0 | ACKSTAT | TRSTAT | ACKTIM | — | — | BCL | GCSTAT | ADD10 | IWCOL | I2COV | D/A | P | S | R/W | RBF | TBF | 0000 | |
| 0020 | I2C1ADD | 31:16 | — | — | — | — | — | — | — | — | — | — | — | — | — | — | — | — | — | 0000 |
| | | 15:0 | — | — | — | — | — | — | — | — | — | — | — | — | — | — | — | — | — | Address Register |
| 0030 | I2C1MSK | 31:16 | — | — | — | — | — | — | — | — | — | — | — | — | — | — | — | — | — | 0000 |
| | | 15:0 | — | — | — | — | — | — | — | — | — | — | — | — | — | — | — | — | — | Address Mask Register |
| 0040 | I2C1BRG | 31:16 | — | — | — | — | — | — | — | — | — | — | — | — | — | — | — | — | — | 0000 |
| | | 15:0 | — | — | — | — | — | — | — | — | — | — | — | — | — | — | — | — | — | Baud Rate Generator Register |
| 0050 | I2C1TRN | 31:16 | — | — | — | — | — | — | — | — | — | — | — | — | — | — | — | — | — | 0000 |
| | | 15:0 | — | — | — | — | — | — | — | — | — | — | — | — | — | — | — | — | — | Transmit Register |
| 0060 | I2C1RCV | 31:16 | — | — | — | — | — | — | — | — | — | — | — | — | — | — | — | — | — | 0000 |
| | | 15:0 | — | — | — | — | — | — | — | — | — | — | — | — | — | — | — | — | — | Receive Register |
| 0200 | I2C2CON ⁽²⁾ | 31:16 | — | — | — | — | — | — | — | — | — | — | PCIE | SCIE | BOEN | SDAHT | SBCDE | AHEN | DHEN | 0000 |
| | | 15:0 | ON | — | SIDL | SCLREL | STRICT | A10M | DISSLW | SMEN | GCEN | STREN | ACKDT | ACKEN | RCEN | PEN | RSEN | SEN | 1000 | |
| 0210 | I2C2STAT ⁽²⁾ | 31:16 | — | — | — | — | — | — | — | — | — | — | — | — | — | — | — | — | — | 0000 |
| | | 15:0 | ACKSTAT | TRSTAT | ACKTIM | — | — | BCL | GCSTAT | ADD10 | IWCOL | I2COV | D/A | P | S | R/W | RBF | TBF | 0000 | |
| 0220 | I2C2ADD ⁽²⁾ | 31:16 | — | — | — | — | — | — | — | — | — | — | — | — | — | — | — | — | — | 0000 |
| | | 15:0 | — | — | — | — | — | — | — | — | — | — | — | — | — | — | — | — | — | Address Register |
| 0230 | I2C2MSK ⁽²⁾ | 31:16 | — | — | — | — | — | — | — | — | — | — | — | — | — | — | — | — | — | 0000 |
| | | 15:0 | — | — | — | — | — | — | — | — | — | — | — | — | — | — | — | — | — | Address Mask Register |
| 0240 | I2C2BRG ⁽²⁾ | 31:16 | — | — | — | — | — | — | — | — | — | — | — | — | — | — | — | — | — | 0000 |
| | | 15:0 | — | — | — | — | — | — | — | — | — | — | — | — | — | — | — | — | — | Baud Rate Generator Register |
| 0250 | I2C2TRN ⁽²⁾ | 31:16 | — | — | — | — | — | — | — | — | — | — | — | — | — | — | — | — | — | 0000 |
| | | 15:0 | — | — | — | — | — | — | — | — | — | — | — | — | — | — | — | — | — | Transmit Register |
| 0260 | I2C2RCV ⁽²⁾ | 31:16 | — | — | — | — | — | — | — | — | — | — | — | — | — | — | — | — | — | 0000 |
| | | 15:0 | — | — | — | — | — | — | — | — | — | — | — | — | — | — | — | — | — | Receive Register |
| 0400 | I2C3CON | 31:16 | — | — | — | — | — | — | — | — | — | — | PCIE | SCIE | BOEN | SDAHT | SBCDE | AHEN | DHEN | 0000 |
| | | 15:0 | ON | — | SIDL | SCLREL | STRICT | A10M | DISSLW | SMEN | GCEN | STREN | ACKDT | ACKEN | RCEN | PEN | RSEN | SEN | 1000 | |
| 0410 | I2C3STAT | 31:16 | — | — | — | — | — | — | — | — | — | — | — | — | — | — | — | — | — | 0000 |
| | | 15:0 | ACKSTAT | TRSTAT | ACKTIM | — | — | BCL | GCSTAT | ADD10 | IWCOL | I2COV | D/A | P | S | R/W | RBF | TBF | 0000 | |
| 0420 | I2C3ADD | 31:16 | — | — | — | — | — | — | — | — | — | — | — | — | — | — | — | — | — | 0000 |
| | | 15:0 | — | — | — | — | — | — | — | — | — | — | — | — | — | — | — | — | — | Address Register |

Legend: x = unknown value on Reset; — = unimplemented, read as '0'. Reset values are shown in hexadecimal.

Note 1: All registers in this table except I2CxRCV have corresponding CLR, SET and INV registers at their virtual addresses, plus offsets of 0x4, 0x8 and 0xC, respectively. See [Section 12.3 “CLR, SET, and INV Registers”](#) for more information.

2: This register is not available on 64-pin devices.

TABLE 21-1: I2C1 THROUGH I2C5 REGISTER MAP (CONTINUED)

| Virtual Address (BF82_#) | Register Name(f) | Bit Range | Bits | | | | | | | | | | | | | | All Resets | | |
|-----------------------------|---------------------|-----------|------------------------------|--------|--------|--------|--------|-------|--------|-------|-------|-------|------|------|-------|-------|------------|------|------|
| | | | 31/15 | 30/14 | 29/13 | 28/12 | 27/11 | 26/10 | 25/9 | 24/8 | 23/7 | 22/6 | 21/5 | 20/4 | 19/3 | 18/2 | | 17/1 | 16/0 |
| 0430 | I2C3MSK | 31:16 | — | — | — | — | — | — | — | — | — | — | — | — | — | — | — | — | 0000 |
| | | 15:0 | Address Mask Register | | | | | | | | | | | | | | 0000 | | |
| 0440 | I2C3BRG | 31:16 | — | — | — | — | — | — | — | — | — | — | — | — | — | — | — | — | 0000 |
| | | 15:0 | Baud Rate Generator Register | | | | | | | | | | | | | | 0000 | | |
| 0450 | I2C3TRN | 31:16 | — | — | — | — | — | — | — | — | — | — | — | — | — | — | — | — | 0000 |
| | | 15:0 | Transmit Register | | | | | | | | | | | | | | 0000 | | |
| 0460 | I2C3RCV | 31:16 | — | — | — | — | — | — | — | — | — | — | — | — | — | — | — | — | 0000 |
| | | 15:0 | Receive Register | | | | | | | | | | | | | | 0000 | | |
| 0600 | I2C4CON | 31:16 | — | — | — | — | — | — | — | — | — | — | — | — | — | — | — | — | 0000 |
| | | 15:0 | ON | — | SIDL | SCLREL | STRICT | A10M | DISSLW | SMEN | GCEN | PCIE | SCIE | BOEN | SDAHT | SBCDE | AHEN | DHEN | 1000 |
| 0610 | I2C4STAT | 31:16 | — | — | — | — | — | — | — | — | — | — | — | — | — | — | — | — | 0000 |
| | | 15:0 | ACKSTAT | TRSTAT | ACKTIM | — | — | BCL | GCSTAT | ADD10 | IWCOL | I2COV | D/A | P | S | R/W | RBF | TBF | 0000 |
| 0620 | I2C4ADD | 31:16 | — | — | — | — | — | — | — | — | — | — | — | — | — | — | — | — | 0000 |
| | | 15:0 | Address Register | | | | | | | | | | | | | | 0000 | | |
| 0630 | I2C4MSK | 31:16 | — | — | — | — | — | — | — | — | — | — | — | — | — | — | — | — | 0000 |
| | | 15:0 | Address Mask Register | | | | | | | | | | | | | | 0000 | | |
| 0640 | I2C4BRG | 31:16 | — | — | — | — | — | — | — | — | — | — | — | — | — | — | — | — | 0000 |
| | | 15:0 | Baud Rate Generator Register | | | | | | | | | | | | | | 0000 | | |
| 0650 | I2C4TRN | 31:16 | — | — | — | — | — | — | — | — | — | — | — | — | — | — | — | — | 0000 |
| | | 15:0 | Transmit Register | | | | | | | | | | | | | | 0000 | | |
| 0660 | I2C4RCV | 31:16 | — | — | — | — | — | — | — | — | — | — | — | — | — | — | — | — | 0000 |
| | | 15:0 | Receive Register | | | | | | | | | | | | | | 0000 | | |
| 0800 | I2C5CON | 31:16 | — | — | — | — | — | — | — | — | — | — | — | — | — | — | — | — | 0000 |
| | | 15:0 | ON | — | SIDL | SCLREL | STRICT | A10M | DISSLW | SMEN | GCEN | PCIE | SCIE | BOEN | SDAHT | SBCDE | AHEN | DHEN | 1000 |
| 0810 | I2C5STAT | 31:16 | — | — | — | — | — | — | — | — | — | — | — | — | — | — | — | — | 0000 |
| | | 15:0 | ACKSTAT | TRSTAT | ACKTIM | — | — | BCL | GCSTAT | ADD10 | IWCOL | I2COV | D/A | P | S | R/W | RBF | TBF | 0000 |
| 0820 | I2C5ADD | 31:16 | — | — | — | — | — | — | — | — | — | — | — | — | — | — | — | — | 0000 |
| | | 15:0 | Address Register | | | | | | | | | | | | | | 0000 | | |
| 0830 | I2C5MSK | 31:16 | — | — | — | — | — | — | — | — | — | — | — | — | — | — | — | — | 0000 |
| | | 15:0 | Address Mask Register | | | | | | | | | | | | | | 0000 | | |
| 0840 | I2C5BRG | 31:16 | — | — | — | — | — | — | — | — | — | — | — | — | — | — | — | — | 0000 |
| | | 15:0 | Baud Rate Generator Register | | | | | | | | | | | | | | 0000 | | |
| 0850 | I2C5TRN | 31:16 | — | — | — | — | — | — | — | — | — | — | — | — | — | — | — | — | 0000 |
| | | 15:0 | Transmit Register | | | | | | | | | | | | | | 0000 | | |
| 0860 | I2C5RCV | 31:16 | — | — | — | — | — | — | — | — | — | — | — | — | — | — | — | — | 0000 |
| | | 15:0 | Receive Register | | | | | | | | | | | | | | 0000 | | |

Legend: x = unknown value on Reset; — = unimplemented, read as '0'. Reset values are shown in hexadecimal.

Note 1: All registers in this table except I2CxRCV have corresponding CLR, SET and INV registers at their virtual addresses, plus offsets of 0x4, 0x8 and 0xC, respectively. See [Section 12.3 “CLR, SET, and INV Registers”](#) for more information.

2: This register is not available on 64-pin devices.

PIC32MZ Embedded Connectivity with Floating Point Unit (EF) Family

REGISTER 21-1: I2CxCON: I²C CONTROL REGISTER

| Bit Range | Bit 31/23/15/7 | Bit 30/22/14/6 | Bit 29/21/13/5 | Bit 28/20/12/4 | Bit 27/19/11/3 | Bit 26/18/10/2 | Bit 25/17/9/1 | Bit 24/16/8/0 |
|-----------|----------------|----------------|----------------|----------------|----------------|----------------|---------------|---------------|
| 31:24 | U-0 | U-0 | U-0 | U-0 | U-0 | U-0 | U-0 | U-0 |
| | — | — | — | — | — | — | — | — |
| 23:16 | U-0 | R/W-0 | R/W-0 | R/W-0 | R/W-0 | R/W-0 | R/W-0 | R/W-0 |
| | — | PCIE | SCIE | BOEN | SDAHT | SBCDE | AHEN | DHEN |
| 15:8 | R/W-0 | U-0 | R/W-0 | R/W-1, HC | R/W-0 | R/W-0 | R/W-0 | R/W-0 |
| | ON | — | SIDL | SCKREL | STRICT | A10M | DISSLW | SMEN |
| 7:0 | R/W-0 | R/W-0 | R/W-0 | R/W-0, HC | R/W-0, HC | R/W-0, HC | R/W-0, HC | R/W-0, HC |
| | GCEN | STREN | ACKDT | ACKEN | RCEN | PEN | RSEN | SEN |

Legend:

R = Readable bit
-n = Value at POR

HC = Cleared in Hardware

W = Writable bit

'1' = Bit is set

U = Unimplemented bit, read as '0'

'0' = Bit is cleared

x = Bit is unknown

bit 31-23 **Unimplemented:** Read as '0'

bit 22 **PCIE:** Stop Condition Interrupt Enable bit (I²C Slave mode only)

1 = Enable interrupt on detection of Stop condition
0 = Stop detection interrupts are disabled

bit 21 **SCIE:** Start Condition Interrupt Enable bit (I²C Slave mode only)

1 = Enable interrupt on detection of Start or Restart conditions
0 = Start detection interrupts are disabled

bit 20 **BOEN:** Buffer Overwrite Enable bit (I²C Slave mode only)

1 = I2CxRCV is updated and ACK is generated for a received address/data byte, ignoring the state of the I2COV bit (I2CxSTAT<6>) only if the RBF bit (I2CxSTAT<2>) = 0
0 = I2CxRCV is only updated when the I2COV bit (I2CxSTAT<6>) is clear

bit 19 **SDAHT:** SDA Hold Time Selection bit

1 = Minimum of 300 ns hold time on SDA after the falling edge of SCL
0 = Minimum of 100 ns hold time on SDA after the falling edge of SCL

bit 18 **SBCDE:** Slave Mode Bus Collision Detect Enable bit (I²C Slave mode only)

1 = Enable slave bus collision interrupts
0 = Slave bus collision interrupts are disabled

bit 18 **AHEN:** Address Hold Enable bit (Slave mode only)

1 = Following the 8th falling edge of SCL for a matching received address byte; SCKREL bit will be cleared and the SCL will be held low.
0 = Address holding is disabled

bit 16 **DHEN:** Data Hold Enable bit (I²C Slave mode only)

1 = Following the 8th falling edge of SCL for a received data byte; slave hardware clears the SCKREL bit and SCL is held low
0 = Data holding is disabled

bit 15 **ON:** I²C Enable bit

1 = Enables the I²C module and configures the SDA and SCL pins as serial port pins
0 = Disables the I²C module; all I²C pins are controlled by PORT functions

bit 14 **Unimplemented:** Read as '0'

bit 13 **SIDL:** Stop in Idle Mode bit

1 = Discontinue module operation when device enters Idle mode
0 = Continue module operation in Idle mode

PIC32MZ Embedded Connectivity with Floating Point Unit (EF) Family

REGISTER 21-1: I2CxCON: I²C CONTROL REGISTER (CONTINUED)

- bit 12 **SCLREL:** SCLx Release Control bit (when operating as I²C slave)
1 = Release SCLx clock
0 = Hold SCLx clock low (clock stretch)
If STREN = 1:
Bit is R/W (i.e., software can write '0' to initiate stretch and write '1' to release clock). Hardware clear at beginning of slave transmission. Hardware clear at end of slave reception.
If STREN = 0:
Bit is R/S (i.e., software can only write '1' to release clock). Hardware clear at beginning of slave transmission.
- bit 11 **STRICT:** Strict I²C Reserved Address Rule Enable bit
1 = Strict reserved addressing is enforced. Device does not respond to reserved address space or generate addresses in reserved address space.
0 = Strict I²C Reserved Address Rule not enabled
- bit 10 **A10M:** 10-bit Slave Address bit
1 = I2CxADD is a 10-bit slave address
0 = I2CxADD is a 7-bit slave address
- bit 9 **DISSLW:** Disable Slew Rate Control bit
1 = Slew rate control disabled
0 = Slew rate control enabled
- bit 8 **SMEN:** SMBus Input Levels bit
1 = Enable I/O pin thresholds compliant with SMBus specification
0 = Disable SMBus input thresholds
- bit 7 **GCEN:** General Call Enable bit (when operating as I²C slave)
1 = Enable interrupt when a general call address is received in the I2CxRSR (module is enabled for reception)
0 = General call address disabled
- bit 6 **STREN:** SCLx Clock Stretch Enable bit (when operating as I²C slave)
Used in conjunction with SCLREL bit.
1 = Enable software or receive clock stretching
0 = Disable software or receive clock stretching
- bit 5 **ACKDT:** Acknowledge Data bit (when operating as I²C master, applicable during master receive)
Value that is transmitted when the software initiates an Acknowledge sequence.
1 = Send NACK during Acknowledge
0 = Send ACK during Acknowledge
- bit 4 **ACKEN:** Acknowledge Sequence Enable bit (when operating as I²C master, applicable during master receive)
1 = Initiate Acknowledge sequence on SDAx and SCLx pins and transmit ACKDT data bit. Hardware clear at end of master Acknowledge sequence.
0 = Acknowledge sequence not in progress
- bit 3 **RCEN:** Receive Enable bit (when operating as I²C master)
1 = Enables Receive mode for I²C. Hardware clear at end of eighth bit of master receive data byte.
0 = Receive sequence not in progress
- bit 2 **PEN:** Stop Condition Enable bit (when operating as I²C master)
1 = Initiate Stop condition on SDAx and SCLx pins. Hardware clear at end of master Stop sequence.
0 = Stop condition not in progress
- bit 1 **RSEN:** Repeated Start Condition Enable bit (when operating as I²C master)
1 = Initiate Repeated Start condition on SDAx and SCLx pins. Hardware clear at end of master Repeated Start sequence.
0 = Repeated Start condition not in progress
- bit 0 **SEN:** Start Condition Enable bit (when operating as I²C master)
1 = Initiate Start condition on SDAx and SCLx pins. Hardware clear at end of master Start sequence.
0 = Start condition not in progress

PIC32MZ Embedded Connectivity with Floating Point Unit (EF) Family

REGISTER 21-2: I2CxSTAT: I²C STATUS REGISTER

| Bit Range | Bit 31/23/15/7 | Bit 30/22/14/6 | Bit 29/21/13/5 | Bit 28/20/12/4 | Bit 27/19/11/3 | Bit 26/18/10/2 | Bit 25/17/9/1 | Bit 24/16/8/0 |
|-----------|------------------------|------------------------|-------------------------|--------------------|--------------------|--------------------|-----------------------|----------------------|
| 31:24 | U-0 — | U-0 — | U-0 — | U-0 — | U-0 — | U-0 — | U-0 — | U-0 — |
| 23:16 | U-0 — | U-0 — | U-0 — | U-0 — | U-0 — | U-0 — | U-0 — | U-0 — |
| 15:8 | R-0, HS, HC ACKSTAT | R-0, HS, HC TRSTAT | R/C-0, HS, HC ACKTIM | U-0 — | U-0 — | R/C-0, HS BCL | R-0, HS, HC GCSTAT | R-0, HS, HC ADD10 |
| | R/C-0, HS, SC IWCOL | R/C-0, HS, SC I2COV | R-0, HS, HC D_A | R/C-0, HS, HC P | R/C-0, HS, HC S | R-0, HS, HC R_W | R-0, HS, HC RBF | R-0, HS, HC TBF |

| | | | |
|-------------------|-------------------|------------------------------------|-----------------------|
| Legend: | HS = Hardware Set | HC = Hardware Cleared | SC = Software Cleared |
| R = Readable bit | W = Writable bit | U = Unimplemented bit, read as '0' | |
| -n = Value at POR | '1' = Bit is set | '0' = Bit is cleared | C = Clearable bit |

bit 31-16 **Unimplemented:** Read as '0'

bit 15 **ACKSTAT:** Acknowledge Status bit
(when operating as I²C™ master, applicable to master transmit operation)
1 = NACK received from slave
0 = ACK received from slave
Hardware set or clear at end of slave Acknowledge.

bit 14 **TRSTAT:** Transmit Status bit (when operating as I²C master, applicable to master transmit operation)
1 = Master transmit is in progress (8 bits + ACK)
0 = Master transmit is not in progress
Hardware set at beginning of master transmission. Hardware clear at end of slave Acknowledge.

bit 13 **ACKTIM:** Acknowledge Time Status bit (Valid in I²C Slave mode only)
1 = I²C bus is in an Acknowledge sequence, set on 8th falling edge of SCL clock
0 = Not an Acknowledge sequence, cleared on 9th rising edge of SCL clock

bit 12-11 **Unimplemented:** Read as '0'

bit 10 **BCL:** Master Bus Collision Detect bit
1 = A bus collision has been detected during a master operation
0 = No collision
Hardware set at detection of bus collision.

bit 9 **GCSTAT:** General Call Status bit
1 = General call address was received
0 = General call address was not received
Hardware set when address matches general call address. Hardware clear at Stop detection.

bit 8 **ADD10:** 10-bit Address Status bit
1 = 10-bit address was matched
0 = 10-bit address was not matched
Hardware set at match of 2nd byte of matched 10-bit address. Hardware clear at Stop detection.

bit 7 **IWCOL:** Write Collision Detect bit
1 = An attempt to write the I2CxTRN register failed because the I²C module is busy
0 = No collision
Hardware set at occurrence of write to I2CxTRN while busy (cleared by software).

bit 6 **I2COV:** Receive Overflow Flag bit
1 = A byte was received while the I2CxRCV register is still holding the previous byte
0 = No overflow
Hardware set at attempt to transfer I2CxRSR to I2CxRCV (cleared by software).

PIC32MZ Embedded Connectivity with Floating Point Unit (EF) Family

REGISTER 21-2: I2CxSTAT: I²C STATUS REGISTER (CONTINUED)

- bit 5 **D_A:** Data/Address bit (when operating as I²C slave)
 1 = Indicates that the last byte received was data
 0 = Indicates that the last byte received was device address
 Hardware clear at device address match. Hardware set by reception of slave byte.
- bit 4 **P:** Stop bit
 1 = Indicates that a Stop bit has been detected last
 0 = Stop bit was not detected last
 Hardware set or clear when Start, Repeated Start or Stop detected.
- bit 3 **S:** Start bit
 1 = Indicates that a Start (or Repeated Start) bit has been detected last
 0 = Start bit was not detected last
 Hardware set or clear when Start, Repeated Start or Stop detected.
- bit 2 **R_W:** Read/Write Information bit (when operating as I²C slave)
 1 = Read – indicates data transfer is output from slave
 0 = Write – indicates data transfer is input to slave
 Hardware set or clear after reception of I²C device address byte.
- bit 1 **RBF:** Receive Buffer Full Status bit
 1 = Receive complete, I2CxRCV is full
 0 = Receive not complete, I2CxRCV is empty
 Hardware set when I2CxRCV is written with received byte. Hardware clear when software reads I2CxRCV.
- bit 0 **TBF:** Transmit Buffer Full Status bit
 1 = Transmit in progress, I2CxTRN is full
 0 = Transmit complete, I2CxTRN is empty
 Hardware set when software writes I2CxTRN. Hardware clear at completion of data transmission.

22.0 UNIVERSAL ASYNCHRONOUS RECEIVER TRANSMITTER (UART)

Note: This data sheet summarizes the features of the PIC32MZ EF family of devices. It is not intended to be a comprehensive reference source. To complement the information in this data sheet, refer to **Section 21. “Universal Asynchronous Receiver Transmitter (UART)”** (DS60001107) in the “PIC32 Family Reference Manual”, which is available from the Microchip web site (www.microchip.com/PIC32).

The UART module is one of the serial I/O modules available in PIC32MZ EF devices. The UART is a full-duplex, asynchronous communication channel that communicates with peripheral devices and personal computers through protocols, such as RS-232, RS-485, LIN, and IrDA®. The module also supports the hardware flow control option, with \overline{UxCTS} and \overline{UxRTS} pins, and also includes an IrDA encoder and decoder.

The primary features of the UART module are:

- Full-duplex, 8-bit or 9-bit data transmission
- Even, Odd or No Parity options (for 8-bit data)
- One or two Stop bits
- Hardware auto-baud feature
- Hardware flow control option
- Fully integrated Baud Rate Generator (BRG) with 16-bit prescaler
- Baud rates ranging from 76 bps to 25 Mbps at 100 MHz (PBCLK2)
- 8-level deep First-In-First-Out (FIFO) transmit data buffer
- 8-level deep FIFO receive data buffer
- Parity, framing and buffer overrun error detection
- Support for interrupt-only on address detect (9th bit = 1)
- Separate transmit and receive interrupts
- Loopback mode for diagnostic support
- LIN Protocol support
- IrDA encoder and decoder with 16x baud clock output for external IrDA encoder/decoder support

Figure 22-1 illustrates a simplified block diagram of the UART module.

FIGURE 22-1: UART SIMPLIFIED BLOCK DIAGRAM

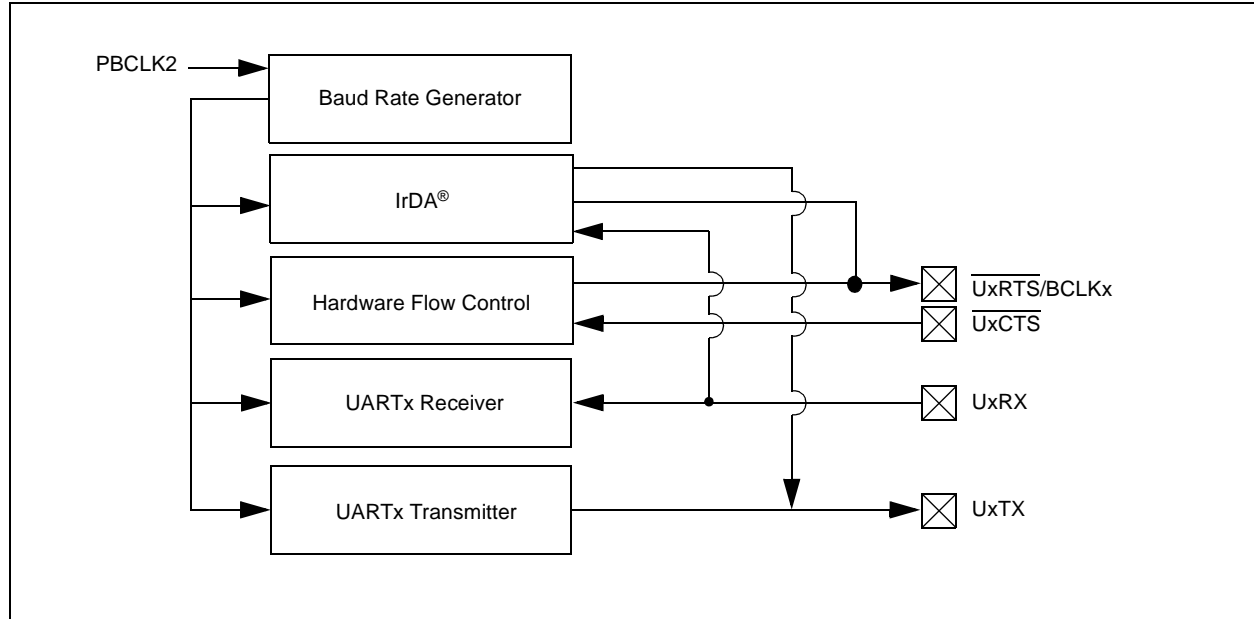

22.1 UART Control Registers

TABLE 22-1: UART1 THROUGH UART6 REGISTER MAP

| Virtual Address (BF82_#) | Register Name | Bit Range | Bits | | | | | | | | | | | | | | | All Resets | |
|--------------------------|-----------------------|-----------|-------|--------------|--------|-------|--------|-------|-------|----------|------|--------|-------|-------|------|------|------|------------|------|
| | | | 31/15 | 30/14 | 29/13 | 28/12 | 27/11 | 26/10 | 25/9 | 24/8 | 23/7 | 22/6 | 21/5 | 20/4 | 19/3 | 18/2 | 17/1 | | 16/0 |
| 2000 | U1MODE ⁽¹⁾ | 31:16 | — | — | — | — | — | — | — | — | — | — | — | — | — | — | — | — | 0000 |
| | | 15:0 | ON | — | SIDL | IREN | RTSMD | — | — | UEN<1:0> | WAKE | LPBACK | ABAUD | RXINV | BRGH | — | — | — | — |
| 2010 | U1STA ⁽¹⁾ | 31:16 | — | — | — | — | — | — | — | ADM_EN | — | — | — | — | — | — | — | — | 0000 |
| | | 15:0 | — | UTXISEL<1:0> | UTXINV | URXEN | UTXBRK | UTXEN | UTXBF | TRMT | — | — | — | — | — | — | — | — | — |
| 2020 | U1TXREG | 31:16 | — | — | — | — | — | — | — | — | — | — | — | — | — | — | — | — | 0000 |
| | | 15:0 | — | — | — | — | — | — | — | TX8 | — | — | — | — | — | — | — | — | 0000 |
| 2030 | U1RXREG | 31:16 | — | — | — | — | — | — | — | — | — | — | — | — | — | — | — | — | 0000 |
| | | 15:0 | — | — | — | — | — | — | — | RX8 | — | — | — | — | — | — | — | — | 0000 |
| 2040 | U1BRG ⁽¹⁾ | 31:16 | — | — | — | — | — | — | — | — | — | — | — | — | — | — | — | — | 0000 |
| | | 15:0 | — | — | — | — | — | — | — | — | — | — | — | — | — | — | — | — | 0000 |
| 2200 | U2MODE ⁽¹⁾ | 31:16 | — | — | — | — | — | — | — | — | — | — | — | — | — | — | — | — | 0000 |
| | | 15:0 | ON | — | SIDL | IREN | RTSMD | — | — | UEN<1:0> | WAKE | LPBACK | ABAUD | RXINV | BRGH | — | — | — | — |
| 2210 | U2STA ⁽¹⁾ | 31:16 | — | — | — | — | — | — | — | ADM_EN | — | — | — | — | — | — | — | — | 0000 |
| | | 15:0 | — | UTXISEL<1:0> | UTXINV | URXEN | UTXBRK | UTXEN | UTXBF | TRMT | — | — | — | — | — | — | — | — | — |
| 2220 | U2TXREG | 31:16 | — | — | — | — | — | — | — | — | — | — | — | — | — | — | — | — | 0000 |
| | | 15:0 | — | — | — | — | — | — | — | TX8 | — | — | — | — | — | — | — | — | 0000 |
| 2230 | U2RXREG | 31:16 | — | — | — | — | — | — | — | — | — | — | — | — | — | — | — | — | 0000 |
| | | 15:0 | — | — | — | — | — | — | — | RX8 | — | — | — | — | — | — | — | — | 0000 |
| 2240 | U2BRG ⁽¹⁾ | 31:16 | — | — | — | — | — | — | — | — | — | — | — | — | — | — | — | — | 0000 |
| | | 15:0 | — | — | — | — | — | — | — | — | — | — | — | — | — | — | — | — | 0000 |
| 2400 | U3MODE ⁽¹⁾ | 31:16 | — | — | — | — | — | — | — | — | — | — | — | — | — | — | — | — | 0000 |
| | | 15:0 | ON | — | SIDL | IREN | RTSMD | — | — | UEN<1:0> | WAKE | LPBACK | ABAUD | RXINV | BRGH | — | — | — | — |
| 2410 | U3STA ⁽¹⁾ | 31:16 | — | — | — | — | — | — | — | ADM_EN | — | — | — | — | — | — | — | — | 0000 |
| | | 15:0 | — | UTXISEL<1:0> | UTXINV | URXEN | UTXBRK | UTXEN | UTXBF | TRMT | — | — | — | — | — | — | — | — | — |
| 2420 | U3TXREG | 31:16 | — | — | — | — | — | — | — | — | — | — | — | — | — | — | — | — | 0000 |
| | | 15:0 | — | — | — | — | — | — | — | TX8 | — | — | — | — | — | — | — | — | 0000 |
| 2430 | U3RXREG | 31:16 | — | — | — | — | — | — | — | — | — | — | — | — | — | — | — | — | 0000 |
| | | 15:0 | — | — | — | — | — | — | — | RX8 | — | — | — | — | — | — | — | — | 0000 |
| 2440 | U3BRG ⁽¹⁾ | 31:16 | — | — | — | — | — | — | — | — | — | — | — | — | — | — | — | — | 0000 |
| | | 15:0 | — | — | — | — | — | — | — | — | — | — | — | — | — | — | — | — | 0000 |

Legend: x = unknown value on Reset; — = unimplemented, read as '0'. Reset values are shown in hexadecimal.

Note 1: This register has corresponding CLR, SET and INV registers at its virtual address, plus an offset of 0x4, 0x8 and 0xC, respectively. See [Section 12.3 "CLR, SET, and INV Registers"](#) for more information.

TABLE 22-1: UART1 THROUGH UART6 REGISTER MAP (CONTINUED)

| Virtual Address (BF82_#) | Register Name | Bit Range | Bits | | | | | | | | | | | | | | All Resets | | |
|-----------------------------|-----------------------|-----------|--------------|--------|-------|--------|-------|-------|------|----------|--------------|--------|-------|-------|------|------|------------|------------|-------|
| | | | 31/15 | 30/14 | 29/13 | 28/12 | 27/11 | 26/10 | 25/9 | 24/8 | 23/7 | 22/6 | 21/5 | 20/4 | 19/3 | 18/2 | | 17/1 | 16/0 |
| 2600 | U4MODE ⁽¹⁾ | 31:16 | — | — | — | — | — | — | — | — | — | — | — | — | — | — | — | — | 0000 |
| | | 15:0 | ON | — | SIDL | IREN | RTSMD | — | — | UEN<1:0> | WAKE | LPBACK | ABAUD | RXINV | BRGH | — | — | PDSEL<1:0> | STSEL |
| 2610 | U4STA ⁽¹⁾ | 31:16 | — | — | — | — | — | — | — | ADM_EN | — | — | — | — | — | — | — | — | 0000 |
| | | 15:0 | UTXISEL<1:0> | UTXINV | URXEN | UTXBRK | UTXEN | UTXBF | TRMT | — | URXISEL<1:0> | ADDEN | RIDLE | PERR | FERR | OERR | — | URXDA | 0110 |
| 2620 | U4TXREG | 31:16 | — | — | — | — | — | — | — | — | — | — | — | — | — | — | — | — | 0000 |
| | | 15:0 | — | — | — | — | — | — | — | TX8 | — | — | — | — | — | — | — | — | 0000 |
| 2630 | U4RXREG | 31:16 | — | — | — | — | — | — | — | — | — | — | — | — | — | — | — | — | 0000 |
| | | 15:0 | — | — | — | — | — | — | — | RX8 | — | — | — | — | — | — | — | — | 0000 |
| 2640 | U4BRG ⁽¹⁾ | 31:16 | — | — | — | — | — | — | — | — | — | — | — | — | — | — | — | — | 0000 |
| | | 15:0 | — | — | — | — | — | — | — | — | — | — | — | — | — | — | — | — | 0000 |
| 2800 | U5MODE ⁽¹⁾ | 31:16 | — | — | — | — | — | — | — | — | — | — | — | — | — | — | — | — | 0000 |
| | | 15:0 | ON | — | SIDL | IREN | RTSMD | — | — | UEN<1:0> | WAKE | LPBACK | ABAUD | RXINV | BRGH | — | — | PDSEL<1:0> | STSEL |
| 2810 | U5STA ⁽¹⁾ | 31:16 | — | — | — | — | — | — | — | ADM_EN | — | — | — | — | — | — | — | — | 0000 |
| | | 15:0 | UTXISEL<1:0> | UTXINV | URXEN | UTXBRK | UTXEN | UTXBF | TRMT | — | URXISEL<1:0> | ADDEN | RIDLE | PERR | FERR | OERR | — | URXDA | 0110 |
| 2820 | U5TXREG | 31:16 | — | — | — | — | — | — | — | — | — | — | — | — | — | — | — | — | 0000 |
| | | 15:0 | — | — | — | — | — | — | — | TX8 | — | — | — | — | — | — | — | — | 0000 |
| 2830 | U5RXREG | 31:16 | — | — | — | — | — | — | — | — | — | — | — | — | — | — | — | — | 0000 |
| | | 15:0 | — | — | — | — | — | — | — | RX8 | — | — | — | — | — | — | — | — | 0000 |
| 2840 | U5BRG ⁽¹⁾ | 31:16 | — | — | — | — | — | — | — | — | — | — | — | — | — | — | — | — | 0000 |
| | | 15:0 | — | — | — | — | — | — | — | — | — | — | — | — | — | — | — | — | 0000 |
| 2A00 | U6MODE ⁽¹⁾ | 31:16 | — | — | — | — | — | — | — | — | — | — | — | — | — | — | — | — | 0000 |
| | | 15:0 | ON | — | SIDL | IREN | RTSMD | — | — | UEN<1:0> | WAKE | LPBACK | ABAUD | RXINV | BRGH | — | — | PDSEL<1:0> | STSEL |
| 2A10 | U6STA ⁽¹⁾ | 31:16 | — | — | — | — | — | — | — | ADM_EN | — | — | — | — | — | — | — | — | 0000 |
| | | 15:0 | UTXISEL<1:0> | UTXINV | URXEN | UTXBRK | UTXEN | UTXBF | TRMT | — | URXISEL<1:0> | ADDEN | RIDLE | PERR | FERR | OERR | — | URXDA | 0110 |
| 2A20 | U6TXREG | 31:16 | — | — | — | — | — | — | — | — | — | — | — | — | — | — | — | — | 0000 |
| | | 15:0 | — | — | — | — | — | — | — | TX8 | — | — | — | — | — | — | — | — | 0000 |
| 2A30 | U6RXREG | 31:16 | — | — | — | — | — | — | — | — | — | — | — | — | — | — | — | — | 0000 |
| | | 15:0 | — | — | — | — | — | — | — | RX8 | — | — | — | — | — | — | — | — | 0000 |
| 2A40 | U6BRG ⁽¹⁾ | 31:16 | — | — | — | — | — | — | — | — | — | — | — | — | — | — | — | — | 0000 |
| | | 15:0 | — | — | — | — | — | — | — | — | — | — | — | — | — | — | — | — | 0000 |

Legend: x = unknown value on Reset; — = unimplemented, read as '0'. Reset values are shown in hexadecimal.

Note 1: This register has corresponding CLR, SET and INV registers at its virtual address, plus an offset of 0x4, 0x8 and 0xC, respectively. See [Section 12.3 "CLR, SET, and INV Registers"](#) for more information.

PIC32MZ Embedded Connectivity with Floating Point Unit (EF) Family

REGISTER 22-1: UxMODE: UARTx MODE REGISTER (CONTINUED)

- bit 5 **ABAUD**: Auto-Baud Enable bit
1 = Enable baud rate measurement on the next character – requires reception of Sync character (0x55);
cleared by hardware upon completion
0 = Baud rate measurement disabled or completed
- bit 4 **RXINV**: Receive Polarity Inversion bit
1 = UxRX Idle state is '0'
0 = UxRX Idle state is '1'
- bit 3 **BRGH**: High Baud Rate Enable bit
1 = High-Speed mode – 4x baud clock enabled
0 = Standard Speed mode – 16x baud clock enabled
- bit 2-1 **PDSEL<1:0>**: Parity and Data Selection bits
11 = 9-bit data, no parity
10 = 8-bit data, odd parity
01 = 8-bit data, even parity
00 = 8-bit data, no parity
- bit 0 **STSEL**: Stop Selection bit
1 = 2 Stop bits
0 = 1 Stop bit

Note 1: These bits are present for legacy compatibility, and are superseded by PPS functionality on these devices (see [Section 12.4 “Peripheral Pin Select \(PPS\)”](#) for more information).

PIC32MZ Embedded Connectivity with Floating Point Unit (EF) Family

REGISTER 22-2: UxSTA: UARTx STATUS AND CONTROL REGISTER

| Bit Range | Bit 31/23/15/7 | Bit 30/22/14/6 | Bit 29/21/13/5 | Bit 28/20/12/4 | Bit 27/19/11/3 | Bit 26/18/10/2 | Bit 25/17/9/1 | Bit 24/16/8/0 |
|-----------|----------------|----------------|----------------|----------------|----------------|----------------|---------------|---------------|
| 31:24 | U-0 | U-0 | U-0 | U-0 | U-0 | U-0 | U-0 | R/W-0 |
| | — | — | — | — | — | — | — | ADM_EN |
| 23:16 | R/W-0 | R/W-0 | R/W-0 | R/W-0 | R/W-0 | R/W-0 | R/W-0 | R/W-0 |
| | ADDR<7:0> | | | | | | | |
| 15:8 | R/W-0 | R/W-0 | R/W-0 | R/W-0 | R/W-0 | R/W-0 | R-0 | R-1 |
| | UTXISEL<1:0> | | UTXINV | URXEN | UTXBRK | UTXEN | UTXBF | TRMT |
| 7:0 | R/W-0 | R/W-0 | R/W-0 | R-1 | R-0 | R-0 | R/W-0 | R-0 |
| | URXISEL<1:0> | | ADDEN | RIDLE | PERR | FERR | OERR | URXDA |

Legend:

R = Readable bit W = Writable bit U = Unimplemented bit, read as '0'
 -n = Value at POR '1' = Bit is set '0' = Bit is cleared x = Bit is unknown

bit 31-25 **Unimplemented:** Read as '0'

bit 24 **ADM_EN:** Automatic Address Detect Mode Enable bit

- 1 = Automatic Address Detect mode is enabled
- 0 = Automatic Address Detect mode is disabled

bit 23-16 **ADDR<7:0>:** Automatic Address Mask bits

When the ADM_EN bit is '1', this value defines the address character to use for automatic address detection.

bit 15-14 **UTXISEL<1:0>:** TX Interrupt Mode Selection bits

- 11 = Reserved, do not use
- 10 = Interrupt is generated and asserted while the transmit buffer is empty
- 01 = Interrupt is generated and asserted when all characters have been transmitted
- 00 = Interrupt is generated and asserted while the transmit buffer contains at least one empty space

bit 13 **UTXINV:** Transmit Polarity Inversion bit

If IrDA mode is disabled (i.e., IREN (UxMODE<12>) is '0'):

- 1 = UxTX Idle state is '0'
- 0 = UxTX Idle state is '1'

If IrDA mode is enabled (i.e., IREN (UxMODE<12>) is '1'):

- 1 = IrDA encoded UxTX Idle state is '1'
- 0 = IrDA encoded UxTX Idle state is '0'

bit 12 **URXEN:** Receiver Enable bit

- 1 = UARTx receiver is enabled. UxRX pin is controlled by UARTx (if ON = 1)
- 0 = UARTx receiver is disabled. UxRX pin is ignored by the UARTx module

bit 11 **UTXBRK:** Transmit Break bit

- 1 = Send Break on next transmission. Start bit followed by twelve '0' bits, followed by Stop bit; cleared by hardware upon completion
- 0 = Break transmission is disabled or completed

bit 10 **UTXEN:** Transmit Enable bit

- 1 = UARTx transmitter is enabled. UxTX pin is controlled by UARTx (if ON = 1)
- 0 = UARTx transmitter is disabled. Any pending transmission is aborted and buffer is reset

bit 9 **UTXBF:** Transmit Buffer Full Status bit (read-only)

- 1 = Transmit buffer is full
- 0 = Transmit buffer is not full, at least one more character can be written

bit 8 **TRMT:** Transmit Shift Register is Empty bit (read-only)

- 1 = Transmit shift register is empty and transmit buffer is empty (the last transmission has completed)
- 0 = Transmit shift register is not empty, a transmission is in progress or queued in the transmit buffer

PIC32MZ Embedded Connectivity with Floating Point Unit (EF) Family

REGISTER 22-2: UxSTA: UARTx STATUS AND CONTROL REGISTER (CONTINUED)

- bit 7-6 **URXISEL<1:0>**: Receive Interrupt Mode Selection bit
11 = Reserved
10 = Interrupt flag bit is asserted while receive buffer is 3/4 or more full
01 = Interrupt flag bit is asserted while receive buffer is 1/2 or more full
00 = Interrupt flag bit is asserted while receive buffer is not empty (i.e., has at least 1 data character)
- bit 5 **ADDEN**: Address Character Detect bit (bit 8 of received data = 1)
1 = Address Detect mode is enabled. If 9-bit mode is not selected, this control bit has no effect
0 = Address Detect mode is disabled
- bit 4 **RIDLE**: Receiver Idle bit (read-only)
1 = Receiver is Idle
0 = Data is being received
- bit 3 **PERR**: Parity Error Status bit (read-only)
1 = Parity error has been detected for the current character
0 = Parity error has not been detected
- bit 2 **FERR**: Framing Error Status bit (read-only)
1 = Framing error has been detected for the current character
0 = Framing error has not been detected
- bit 1 **OERR**: Receive Buffer Overrun Error Status bit.
This bit is set in hardware and can only be cleared (= 0) in software. Clearing a previously set OERR bit resets the receiver buffer and RSR to empty state.
1 = Receive buffer has overflowed
0 = Receive buffer has not overflowed
- bit 0 **URXDA**: Receive Buffer Data Available bit (read-only)
1 = Receive buffer has data, at least one more character can be read
0 = Receive buffer is empty

PIC32MZ Embedded Connectivity with Floating Point Unit (EF) Family

Figure 22-2 and Figure 22-3 illustrate typical receive and transmit timing for the UART module.

FIGURE 22-2: UART RECEPTION

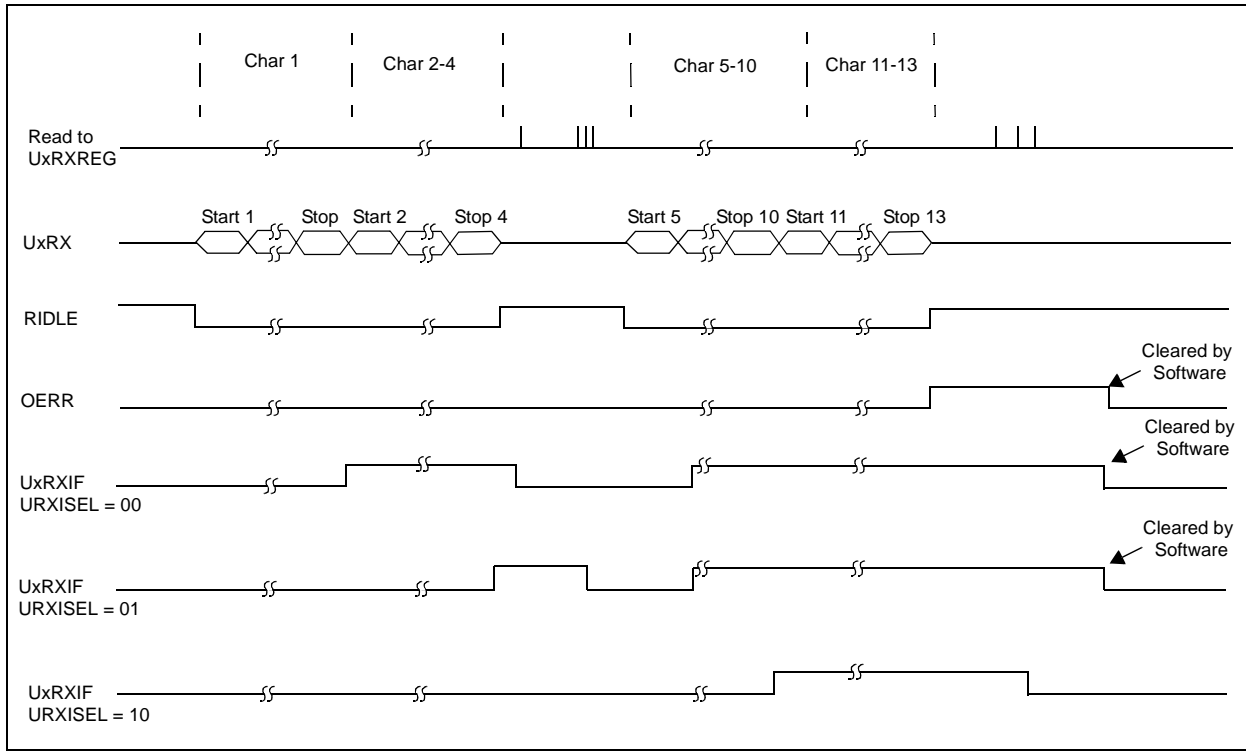
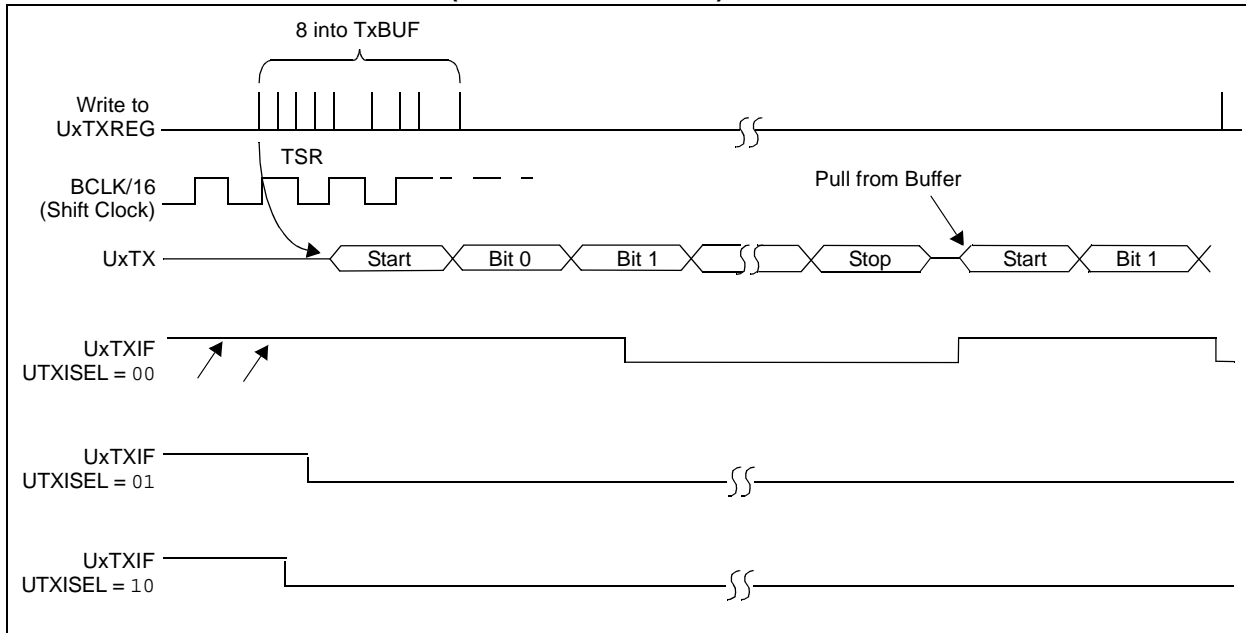

FIGURE 22-3: TRANSMISSION (8-BIT OR 9-BIT DATA)



23.0 PARALLEL MASTER PORT (PMP)

Note: This data sheet summarizes the features of the PIC32MZ EF family of devices. It is not intended to be a comprehensive reference source. To complement the information in this data sheet, refer to **Section 13. “Parallel Master Port (PMP)”** (DS60001128) in the “PIC32 Family Reference Manual”, which is available from the Microchip web site (www.microchip.com/PIC32).

The PMP is a parallel 8-bit/16-bit input/output module specifically designed to communicate with a wide variety of parallel devices, such as communications peripherals, LCDs, external memory devices and microcontrollers. Because the interface to parallel peripherals varies significantly, the PMP module is highly configurable.

Key features of the PMP module include:

- 8-bit, 16-bit interface
- Up to 16 programmable address lines
- Up to two Chip Select lines
- Programmable strobe options:
 - Individual read and write strobes, or
 - Read/write strobe with enable strobe
- Address auto-increment/auto-decrement
- Programmable address/data multiplexing
- Programmable polarity on control signals
- Parallel Slave Port support:
 - Legacy addressable
 - Address support
 - 4-byte deep auto-incrementing buffer
- Programmable Wait states
- Operate during Sleep and Idle modes
- Fast bit manipulation using CLR, SET, and INV registers

Note: On 64-pin devices, data pins PMD<15:8> are not available in 16-bit Master modes.

FIGURE 23-1: PMP MODULE PINOUT AND CONNECTIONS TO EXTERNAL DEVICES

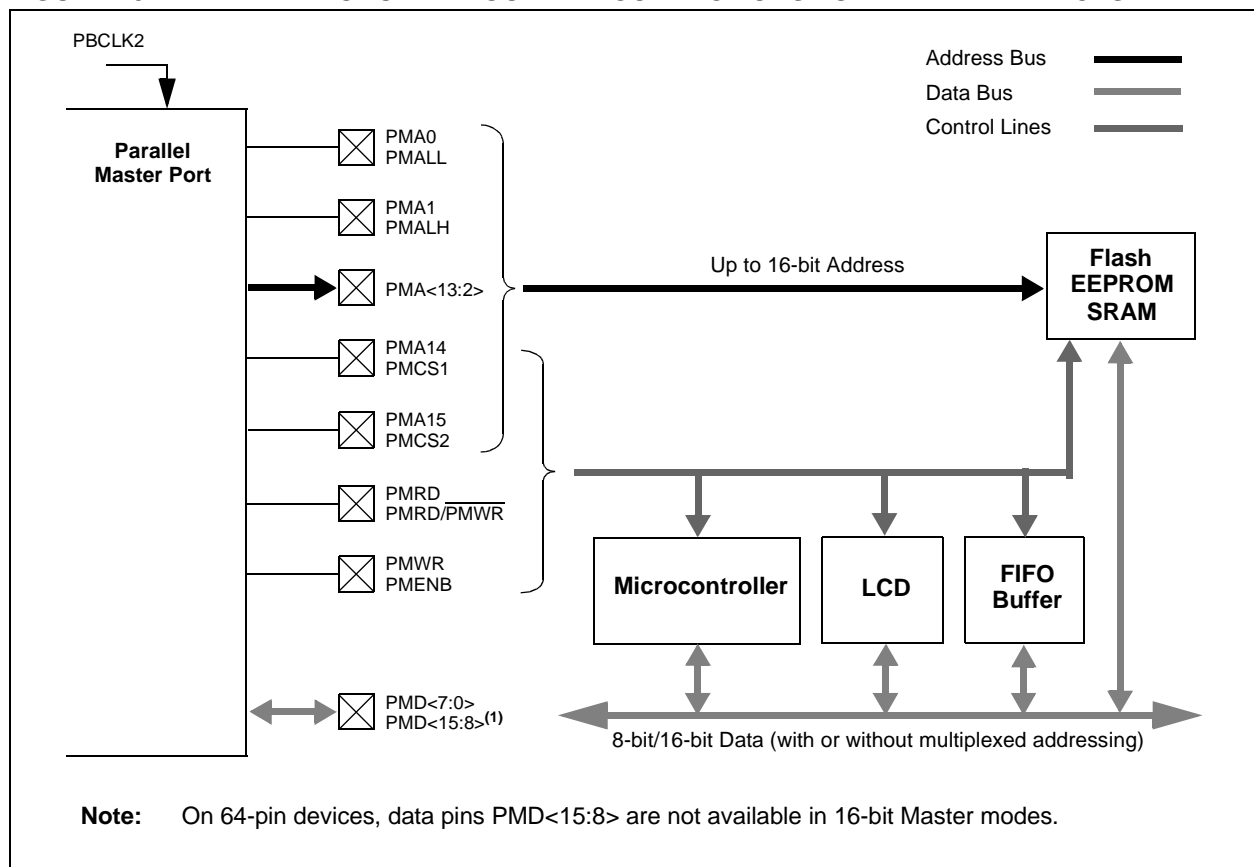

23.1 PMP Control Registers

TABLE 23-1: PARALLEL MASTER PORT REGISTER MAP

| Virtual Address (BF82_#) | Register Name(1) | Bit Range | Bits | | | | | | | | | | | | | | | All Resets | |
|--------------------------|------------------|-----------|---------------|---------------|------------|-------------|-----------|------------|------------|------------|---------|------|------|------|------|------|---------|------------|------|
| | | | 31/15 | 30/14 | 29/13 | 28/12 | 27/11 | 26/10 | 25/9 | 24/8 | 23/7 | 22/6 | 21/5 | 20/4 | 19/3 | 18/2 | 17/1 | | 16/0 |
| E000 | PMCON | 31:16 | — | — | — | — | — | — | — | — | RDSTART | — | — | — | — | — | DUALBUF | — | 0000 |
| | | 15:0 | ON | — | SIDL | ADRMUX<1:0> | PMPCTL | PTWREN | PTRDEN | CSF<1:0> | ALP | CS2P | CS1P | — | — | WRSP | RDSP | 0000 | |
| E010 | PMMODE | 31:16 | — | — | — | — | — | — | — | — | — | — | — | — | — | — | — | 0000 | |
| | | 15:0 | BUSY | IRQM<1:0> | INCM<1:0> | MODE16 | MODE<1:0> | WAITB<1:0> | WAITM<3:0> | WAITE<1:0> | 0000 | | | | | | | | |
| E020 | PMADDR | 31:16 | — | — | — | — | — | — | — | — | — | — | — | — | — | — | — | 0000 | |
| | | 15:0 | CS2 | CS1 | ADDR<13:0> | | | | | | | | | | | | | | 0000 |
| E030 | PMDOUT | 31:16 | — | — | — | — | — | — | — | — | — | — | — | — | — | — | — | 0000 | |
| | | 15:0 | DATAOUT<15:0> | | | | | | | | | | | | | | | 0000 | |
| E040 | PMDIN | 31:16 | — | — | — | — | — | — | — | — | — | — | — | — | — | — | — | 0000 | |
| | | 15:0 | DATAIN<15:0> | | | | | | | | | | | | | | | 0000 | |
| E050 | PMAEN | 31:16 | — | — | — | — | — | — | — | — | — | — | — | — | — | — | — | 0000 | |
| | | 15:0 | PTEN<15:0> | | | | | | | | | | | | | | | 0000 | |
| E060 | PMSTAT | 31:16 | — | — | — | — | — | — | — | — | — | — | — | — | — | — | — | 0000 | |
| | | 15:0 | IBF | IBOV | — | — | IB3F | IB2F | IB1F | IB0F | OBE | OBUF | — | — | OB3E | OB2E | OB1E | OB0E | 008F |
| E070 | PMWADDR | 31:16 | — | — | — | — | — | — | — | — | — | — | — | — | — | — | — | 0000 | |
| | | 15:0 | WCS2 | WCS1 | — | — | — | — | — | — | — | — | — | — | — | — | — | — | 0000 |
| E080 | PMRADDR | 31:16 | — | — | — | — | — | — | — | — | — | — | — | — | — | — | — | 0000 | |
| | | 15:0 | RCS2 | RCS1 | — | — | — | — | — | — | — | — | — | — | — | — | — | — | 0000 |
| E090 | PMRDIN | 31:16 | 31:16 | — | — | — | — | — | — | — | — | — | — | — | — | — | — | 0000 | |
| | | 15:0 | 15:0 | RDATAIN<15:0> | | | | | | | | | | | | | | 0000 | |

Legend: x = unknown value on Reset; — = unimplemented, read as '0'. Reset values are shown in hexadecimal.

Note 1: All registers in this table have corresponding CLR, SET and INV registers at their virtual addresses, plus offsets of 0x4, 0x8 and 0xC, respectively. See [Section 12.3 “CLR, SET, and INV Registers”](#) for more information.

PIC32MZ Embedded Connectivity with Floating Point Unit (EF) Family

REGISTER 23-1: PMCON: PARALLEL PORT CONTROL REGISTER

| Bit Range | Bit 31/23/15/7 | Bit 30/22/14/6 | Bit 29/21/13/5 | Bit 28/20/12/4 | Bit 27/19/11/3 | Bit 26/18/10/2 | Bit 25/17/9/1 | Bit 24/16/8/0 |
|-----------|-------------------------|----------------|--------------------|---------------------|---------------------|----------------|---------------|---------------|
| 31:24 | U-0 | U-0 | U-0 | U-0 | U-0 | U-0 | U-0 | U-0 |
| | — | — | — | — | — | — | — | — |
| 23:16 | R/W-0, HC | U-0 | U-0 | U-0 | U-0 | U-0 | R/W-0 | U-0 |
| | RDSTART | — | — | — | — | — | DUALBUF | — |
| 15:8 | R/W-0 | U-0 | R/W-0 | R/W-0 | R/W-0 | R/W-0 | R/W-0 | R/W-0 |
| | ON | — | SIDL | ADRMUX<1:0> | | PMPTTL | PTWREN | PTRDEN |
| 7:0 | R/W-0 | R/W-0 | R/W-0 | R/W-0 | R/W-0 | U-0 | R/W-0 | R/W-0 |
| | CSF<1:0> ⁽¹⁾ | | ALP ⁽¹⁾ | CS2P ⁽¹⁾ | CS1P ⁽¹⁾ | — | WRSP | RDSP |

Legend:

R = Readable bit
-n = Value at POR

W = Writable bit
'1' = Bit is set

U = Unimplemented bit, read as '0'
'0' = Bit is cleared
x = Bit is unknown

bit 31-24 **Unimplemented:** Read as '0'

bit 23 **RDSTART:** Start Read on PMP Bus bit
This bit is cleared by hardware at the end of the read cycle.
1 = Start a read cycle on the PMP bus
0 = No effect

bit 22-18 **Unimplemented:** Read as '0'

bit 17 **DUALBUF:** Dual Read/Write Buffers enable bit
This bit is valid in Master mode only.
1 = PMP uses separate registers for reads and writes (PMRADDR, PMDATAIN, PMWADDR, PMDATAOUT)
0 = PMP uses legacy registers (PMADDR, PMDATA)

bit 16 **Unimplemented:** Read as '0'

bit 15 **ON:** Parallel Master Port Enable bit
1 = PMP enabled
0 = PMP disabled, no off-chip access performed

bit 14 **Unimplemented:** Read as '0'

bit 13 **SIDL:** Stop in Idle Mode bit
1 = Discontinue module operation when device enters Idle mode
0 = Continue module operation in Idle mode

bit 12-11 **ADRMUX<1:0>:** Address/Data Multiplexing Selection bits
11 = Lower 8 bits of address are multiplexed on PMD<15:0> pins; upper 8 bits are not used
10 = All 16 bits of address are multiplexed on PMD<15:0> pins
01 = Lower 8 bits of address are multiplexed on PMD<7:0> pins, upper bits are on PMA<15:8>
00 = Address and data appear on separate pins

bit 10 **PMPTTL:** PMP Module TTL Input Buffer Select bit
1 = PMP module uses TTL input buffers
0 = PMP module uses Schmitt Trigger input buffer

bit 9 **PTWREN:** Write Enable Strobe Port Enable bit
1 = PMWR/PMENB port enabled
0 = PMWR/PMENB port disabled

bit 8 **PTRDEN:** Read/Write Strobe Port Enable bit
1 = PMRD/PMWR port enabled
0 = PMRD/PMWR port disabled

Note 1: These bits have no effect when their corresponding pins are used as address lines.

PIC32MZ Embedded Connectivity with Floating Point Unit (EF) Family

REGISTER 23-1: PMCON: PARALLEL PORT CONTROL REGISTER (CONTINUED)

- bit 7-6 **CSF<1:0>**: Chip Select Function bits⁽¹⁾
11 = Reserved
10 = PMCS1 and PMCS2 function as Chip Select
01 = PMCS2 functions as Chip Select and PMCS1 functions as address bit 14
00 = PMCS1 and PMCS2 function as address bit 14 and address bit 15
- bit 5 **ALP**: Address Latch Polarity bit⁽¹⁾
1 = Active-high (PMALL and PMALH)
0 = Active-low (PMALL and PMALH)
- bit 4 **CS2P**: Chip Select 2 Polarity bit⁽¹⁾
1 = Active-high (PMCS2)
0 = Active-low (PMCS2)
- bit 3 **CS1P**: Chip Select 1 Polarity bit⁽¹⁾
1 = Active-high (PMCS1)
0 = Active-low (PMCS1)
- bit 2 **Unimplemented**: Read as '0'
- bit 1 **WRSP**: Write Strobe Polarity bit
For Slave Modes and Master mode 2 (MODE<1:0> = 00,01,10):
1 = Write strobe active-high (PMWR)
0 = Write strobe active-low (PMWR)
For Master mode 1 (MODE<1:0> = 11):
1 = Enable strobe active-high (PMENB)
0 = Enable strobe active-low (PMENB)
- bit 0 **RDSP**: Read Strobe Polarity bit
For Slave modes and Master mode 2 (MODE<1:0> = 00,01,10):
1 = Read Strobe active-high (PMRD)
0 = Read Strobe active-low (PMRD)
For Master mode 1 (MODE<1:0> = 11):
1 = Read/write strobe active-high (PMRD/PMWR)
0 = Read/write strobe active-low (PMRD/PMWR)

Note 1: These bits have no effect when their corresponding pins are used as address lines.

PIC32MZ Embedded Connectivity with Floating Point Unit (EF) Family

REGISTER 23-2: PMMODE: PARALLEL PORT MODE REGISTER

| Bit Range | Bit 31/23/15/7 | Bit 30/22/14/6 | Bit 29/21/13/5 | Bit 28/20/12/4 | Bit 27/19/11/3 | Bit 26/18/10/2 | Bit 25/17/9/1 | Bit 24/16/8/0 |
|-----------|---------------------------|----------------|---------------------------|----------------|----------------|----------------|---------------------------|---------------|
| 31:24 | U-0 | U-0 | U-0 | U-0 | U-0 | U-0 | U-0 | U-0 |
| | — | — | — | — | — | — | — | — |
| 23:16 | U-0 | U-0 | U-0 | U-0 | U-0 | U-0 | U-0 | U-0 |
| | — | — | — | — | — | — | — | — |
| 15:8 | R-0 | R/W-0 | R/W-0 | R/W-0 | R/W-0 | R/W-0 | R/W-0 | R/W-0 |
| | BUSY | IRQM<1:0> | | INCM<1:0> | | MODE16 | MODE<1:0> | |
| 7:0 | R/W-0 | R/W-0 | R/W-0 | R/W-0 | R/W-0 | R/W-0 | R/W-0 | R/W-0 |
| | WAITB<1:0> ⁽¹⁾ | | WAITM<3:0> ⁽¹⁾ | | | | WAITE<1:0> ⁽¹⁾ | |

Legend:

R = Readable bit
-n = Value at POR

W = Writable bit
'1' = Bit is set

U = Unimplemented bit, read as '0'
'0' = Bit is cleared
x = Bit is unknown

bit 31-16 **Unimplemented:** Read as '0'

bit 15 **BUSY:** Busy bit (Master mode only)

- 1 = Port is busy
- 0 = Port is not busy

bit 14-13 **IRQM<1:0>:** Interrupt Request Mode bits

- 11 = Reserved, do not use
- 10 = Interrupt generated when Read Buffer 3 is read or Write Buffer 3 is written (Buffered PSP mode) or on a read or write operation when PMA<1:0> = 11 (Addressable Slave mode only)
- 01 = Interrupt generated at the end of the read/write cycle
- 00 = No Interrupt generated

bit 12-11 **INCM<1:0>:** Increment Mode bits

- 11 = Slave mode read and write buffers auto-increment (MODE<1:0> = 00 only)
- 10 = Decrement ADDR<15:0> and ADDR<14> by 1 every read/write cycle⁽²⁾
- 01 = Increment ADDR<15:0> and ADDR<14> by 1 every read/write cycle⁽²⁾
- 00 = No increment or decrement of address

bit 10 **MODE16:** 8/16-bit Mode bit

- 1 = 16-bit mode: a read or write to the data register invokes a single 16-bit transfer
- 0 = 8-bit mode: a read or write to the data register invokes a single 8-bit transfer

bit 9-8 **MODE<1:0>:** Parallel Port Mode Select bits

- 11 = Master mode 1 (PMCSx, PMRD/PMWR, PMENB, PMA<x:0>, and PMD<15:0>)⁽³⁾
- 10 = Master mode 2 (PMCSx, PMRD, PMWR, PMA<x:0>, and PMD<15:0>)⁽³⁾
- 01 = Enhanced Slave mode, control signals (PMRD, PMWR, PMCSx, PMD<7:0>, and PMA<1:0>)
- 00 = Legacy Parallel Slave Port, control signals (PMRD, PMWR, PMCSx, and PMD<7:0>)

bit 7-6 **WAITB<1:0>:** Data Setup to Read/Write Strobe Wait States bits⁽¹⁾

- 11 = Data wait of 4 TPBCLK2; multiplexed address phase of 4 TPBCLK2
- 10 = Data wait of 3 TPBCLK2; multiplexed address phase of 3 TPBCLK2
- 01 = Data wait of 2 TPBCLK2; multiplexed address phase of 2 TPBCLK2
- 00 = Data wait of 1 TPBCLK2; multiplexed address phase of 1 TPBCLK2 (default)

Note 1: Whenever WAITM<3:0> = 0000, WAITB and WAITE bits are ignored and forced to 1 TPBCLK2 cycle for a write operation; WAITB = 1 TPBCLK2 cycle, WAITE = 0 TPBCLK2 cycles for a read operation.

2: Address bits 14 and 15 are not subject to auto-increment/decrement if configured as Chip Select.

3: The PMD<15:8> bits are not active if the MODE16 bit = 1.

PIC32MZ Embedded Connectivity with Floating Point Unit (EF) Family

REGISTER 23-2: PMMODE: PARALLEL PORT MODE REGISTER (CONTINUED)

bit 5-2 **WAITM<3:0>**: Data Read/Write Strobe Wait States bits⁽¹⁾

1111 = Wait of 16 TPBCLK2

•
•
•

0001 = Wait of 2 TPBCLK2

0000 = Wait of 1 TPBCLK2 (default)

bit 1-0 **WAITE<1:0>**: Data Hold After Read/Write Strobe Wait States bits⁽¹⁾

11 = Wait of 4 TPBCLK2

10 = Wait of 3 TPBCLK2

01 = Wait of 2 TPBCLK2

00 = Wait of 1 TPBCLK2 (default)

For Read operations:

11 = Wait of 3 TPBCLK2

10 = Wait of 2 TPBCLK2

01 = Wait of 1 TPBCLK2

00 = Wait of 0 TPBCLK2 (default)

Note 1: Whenever WAITM<3:0> = 0000, WAITB and WAITE bits are ignored and forced to 1 TPBCLK2 cycle for a write operation; WAITB = 1 TPBCLK2 cycle, WAITE = 0 TPBCLK2 cycles for a read operation.

2: Address bits 14 and 15 are is not subject to auto-increment/decrement if configured as Chip Select.

3: The PMD<15:8> bits are not active is the MODE16 bit = 1.

PIC32MZ Embedded Connectivity with Floating Point Unit (EF) Family

REGISTER 23-3: PMADDR: PARALLEL PORT ADDRESS REGISTER

| Bit Range | Bit 31/23/15/7 | Bit 30/22/14/6 | Bit 29/21/13/5 | Bit 28/20/12/4 | Bit 27/19/11/3 | Bit 26/18/10/2 | Bit 25/17/9/1 | Bit 24/16/8/0 |
|-----------|-----------------------|-----------------------|----------------|----------------|----------------|----------------|---------------|---------------|
| 31:24 | U-0 | U-0 | U-0 | U-0 | U-0 | U-0 | U-0 | U-0 |
| | — | — | — | — | — | — | — | — |
| 23:16 | U-0 | U-0 | U-0 | U-0 | U-0 | U-0 | U-0 | U-0 |
| | — | — | — | — | — | — | — | — |
| 15:8 | R/W-0 | R/W-0 | R/W-0 | R/W-0 | R/W-0 | R/W-0 | R/W-0 | R/W-0 |
| | CS2 ⁽¹⁾ | CS1 ⁽³⁾ | ADDR<13:8> | | | | | |
| | ADDR15 ⁽²⁾ | ADDR14 ⁽⁴⁾ | | | | | | |
| 7:0 | R/W-0 | R/W-0 | R/W-0 | R/W-0 | R/W-0 | R/W-0 | R/W-0 | R/W-0 |
| | ADDR<7:0> | | | | | | | |

Legend:

R = Readable bit W = Writable bit U = Unimplemented bit, read as '0'
-n = Value at POR '1' = Bit is set '0' = Bit is cleared x = Bit is unknown

bit 31-16 **Unimplemented:** Read as '0'

bit 15 **CS2:** Chip Select 2 bit⁽¹⁾
1 = Chip Select 2 is active
0 = Chip Select 2 is inactive

bit 15 **ADDR<15>:** Target Address bit 15⁽²⁾

bit 14 **CS1:** Chip Select 1 bit⁽³⁾
1 = Chip Select 1 is active
0 = Chip Select 1 is inactive

bit 14 **ADDR<14>:** Target Address bit 14⁽⁴⁾

bit 13-0 **ADDR<13:0>:** Address bits

- Note 1:** When the CSF<1:0> bits (PMCON<7:6>) = 10 or 01.
Note 2: When the CSF<1:0> bits (PMCON<7:6>) = 00.
Note 3: When the CSF<1:0> bits (PMCON<7:6>) = 10.
Note 4: When the CSF<1:0> bits (PMCON<7:6>) = 00 or 01.

Note: If the DUALBUF bit (PMCON<17>) = 0, the bits in this register control both read and write target addressing. If the DUALBUF bit = 1, the bits in this register are not used. In this instance, use the PMRADDR register for Read operations and the PMWADDR register for Write operations.

PIC32MZ Embedded Connectivity with Floating Point Unit (EF) Family

REGISTER 23-6: PMAEN: PARALLEL PORT PIN ENABLE REGISTER

| Bit Range | Bit 31/23/15/7 | Bit 30/22/14/6 | Bit 29/21/13/5 | Bit 28/20/12/4 | Bit 27/19/11/3 | Bit 26/18/10/2 | Bit 25/17/9/1 | Bit 24/16/8/0 |
|-----------|----------------|----------------|----------------|----------------|----------------|----------------|---------------|---------------|
| 31:24 | U-0 | U-0 | U-0 | U-0 | U-0 | U-0 | U-0 | U-0 |
| | — | — | — | — | — | — | — | — |
| 23:16 | U-0 | U-0 | U-0 | U-0 | U-0 | U-0 | U-0 | U-0 |
| | — | — | — | — | — | — | — | — |
| 15:8 | R/W-0 | R/W-0 | R/W-0 | R/W-0 | R/W-0 | R/W-0 | R/W-0 | R/W-0 |
| | PTEN<15:14> | | | PTEN<13:8> | | | | |
| 7:0 | R/W-0 | R/W-0 | R/W-0 | R/W-0 | R/W-0 | R/W-0 | R/W-0 | R/W-0 |
| | PTEN<7:0> | | | | | | | |

Legend:

R = Readable bit

W = Writable bit

U = Unimplemented bit, read as '0'

-n = Value at POR

'1' = Bit is set

'0' = Bit is cleared

x = Bit is unknown

bit 31-15 **Unimplemented:** Read as '0'

bit 15-14 **PTEN<15:14>:** PMCS1 Strobe Enable bits

1 = PMA15 and PMA14 function as either PMA<15:14> or PMCS1 and PMCS2⁽¹⁾

0 = PMA15 and PMA14 function as port I/O

bit 13-2 **PTEN<13:2>:** PMP Address Port Enable bits

1 = PMA<13:2> function as PMP address lines

0 = PMA<13:2> function as port I/O

bit 1-0 **PTEN<1:0>:** PMALH/PMALL Strobe Enable bits

1 = PMA1 and PMA0 function as either PMA<1:0> or PMALH and PMALL⁽²⁾

0 = PMA1 and PMA0 pads function as port I/O

Note 1: The use of these pins as PMA15 and PMA14 or CS1 and CS2 is selected by the CSF<1:0> bits in the PMCON register.

2: The use of these pins as PMA1/PMA0 or PMALH/PMALL depends on the Address/Data Multiplex mode selected by bits ADRMUX<1:0> in the PMCON register.

PIC32MZ Embedded Connectivity with Floating Point Unit (EF) Family

REGISTER 23-7: PMSTAT: PARALLEL PORT STATUS REGISTER (SLAVE MODES ONLY)

| Bit Range | Bit 31/23/15/7 | Bit 30/22/14/6 | Bit 29/21/13/5 | Bit 28/20/12/4 | Bit 27/19/11/3 | Bit 26/18/10/2 | Bit 25/17/9/1 | Bit 24/16/8/0 |
|-----------|----------------|----------------|----------------|----------------|----------------|----------------|---------------|---------------|
| 31:24 | U-0 | U-0 | U-0 | U-0 | U-0 | U-0 | U-0 | U-0 |
| | — | — | — | — | — | — | — | — |
| 23:16 | U-0 | U-0 | U-0 | U-0 | U-0 | U-0 | U-0 | U-0 |
| | — | — | — | — | — | — | — | — |
| 15:8 | R-0 | R/W-0, HS, SC | U-0 | U-0 | R-0 | R-0 | R-0 | R-0 |
| | IBF | IBOV | — | — | IB3F | IB2F | IB1F | IB0F |
| 7:0 | R-1 | R/W-0, HS, SC | U-0 | U-0 | R-1 | R-1 | R-1 | R-1 |
| | OBE | OBUF | — | — | OB3E | OB2E | OB1E | OB0E |

| | | |
|-------------------|-------------------|--|
| Legend: | HS = Hardware Set | SC = Software Cleared |
| R = Readable bit | W = Writable bit | U = Unimplemented bit, read as '0' |
| -n = Value at POR | '1' = Bit is set | '0' = Bit is cleared x = Bit is unknown |

bit 31-16 **Unimplemented:** Read as '0'

bit 15 **IBF:** Input Buffer Full Status bit

1 = All writable input buffer registers are full

0 = Some or all of the writable input buffer registers are empty

bit 14 **IBOV:** Input Buffer Overflow Status bit

1 = A write attempt to a full input byte buffer occurred (must be cleared in software)

0 = No overflow occurred

bit 13-12 **Unimplemented:** Read as '0'

bit 11-8 **IBxF:** Input Buffer x Status Full bits

1 = Input Buffer contains data that has not been read (reading buffer will clear this bit)

0 = Input Buffer does not contain any unread data

bit 7 **OBE:** Output Buffer Empty Status bit

1 = All readable output buffer registers are empty

0 = Some or all of the readable output buffer registers are full

bit 6 **OBUF:** Output Buffer Underflow Status bit

1 = A read occurred from an empty output byte buffer (must be cleared in software)

0 = No underflow occurred

bit 5-4 **Unimplemented:** Read as '0'

bit 3-0 **OBxE:** Output Buffer x Status Empty bits

1 = Output buffer is empty (writing data to the buffer will clear this bit)

0 = Output buffer contains data that has not been transmitted

PIC32MZ Embedded Connectivity with Floating Point Unit (EF) Family

REGISTER 23-8: PMWADDR: PARALLEL PORT WRITE ADDRESS REGISTER

| Bit Range | Bit 31/23/15/7 | Bit 30/22/14/6 | Bit 29/21/13/5 | Bit 28/20/12/4 | Bit 27/19/11/3 | Bit 26/18/10/2 | Bit 25/17/9/1 | Bit 24/16/8/0 |
|-----------|------------------------|------------------------|----------------|----------------|----------------|----------------|---------------|---------------|
| 31:24 | U-0 | U-0 | U-0 | U-0 | U-0 | U-0 | U-0 | U-0 |
| | — | — | — | — | — | — | — | — |
| 23:16 | U-0 | U-0 | U-0 | U-0 | U-0 | U-0 | U-0 | U-0 |
| | — | — | — | — | — | — | — | — |
| 15:8 | R/W-0 | R/W-0 | R/W-0 | R/W-0 | R/W-0 | R/W-0 | R/W-0 | R/W-0 |
| | WCS2 ⁽¹⁾ | WCS1 ⁽³⁾ | WADDR<13:8> | | | | | |
| | WADDR15 ⁽²⁾ | WADDR14 ⁽⁴⁾ | | | | | | |
| 7:0 | R/W-0 | R/W-0 | R/W-0 | R/W-0 | R/W-0 | R/W-0 | R/W-0 | R/W-0 |
| | WADDR<7:0> | | | | | | | |

Legend:

R = Readable bit

W = Writable bit

U = Unimplemented bit, read as '0'

-n = Value at POR

'1' = Bit is set

'0' = Bit is cleared

x = Bit is unknown

bit 31-16 **Unimplemented:** Read as '0'

bit 15 **WCS2:** Chip Select 2 bit⁽¹⁾

1 = Chip Select 2 is active

0 = Chip Select 2 is inactive

bit 15 **WADDR<15>:** Target Address bit 15⁽²⁾

bit 14 **WCS1:** Chip Select 1 bit⁽³⁾

1 = Chip Select 1 is active

0 = Chip Select 1 is inactive

bit 14 **WADDR<14>:** Target Address bit 14⁽⁴⁾

bit 13-0 **WADDR<13:0>:** Address bits

- Note 1:** When the CSF<1:0> bits (PMCON<7:6>) = 10 or 01.
Note 2: When the CSF<1:0> bits (PMCON<7:6>) = 00.
Note 3: When the CSF<1:0> bits (PMCON<7:6>) = 10.
Note 4: When the CSF<1:0> bits (PMCON<7:6>) = 00 or 01.

Note: This register is only used when the DUALBUF bit (PMCON<17>) is set to '1'.

PIC32MZ Embedded Connectivity with Floating Point Unit (EF) Family

REGISTER 23-9: PMRADDR: PARALLEL PORT READ ADDRESS REGISTER

| Bit Range | Bit 31/23/15/7 | Bit 30/22/14/6 | Bit 29/21/13/5 | Bit 28/20/12/4 | Bit 27/19/11/3 | Bit 26/18/10/2 | Bit 25/17/9/1 | Bit 24/16/8/0 |
|-----------|------------------------|------------------------|----------------|----------------|----------------|----------------|---------------|---------------|
| 31:24 | U-0 | U-0 | U-0 | U-0 | U-0 | U-0 | U-0 | U-0 |
| | — | — | — | — | — | — | — | — |
| 23:16 | U-0 | U-0 | U-0 | U-0 | U-0 | U-0 | U-0 | U-0 |
| | — | — | — | — | — | — | — | — |
| 15:8 | R/W-0 | R/W-0 | R/W-0 | R/W-0 | R/W-0 | R/W-0 | R/W-0 | R/W-0 |
| | RCS2 ⁽¹⁾ | RCS1 ⁽³⁾ | RADDR<13:8> | | | | | |
| | RADDR15 ⁽²⁾ | RADDR14 ⁽⁴⁾ | | | | | | |
| 7:0 | R/W-0 | R/W-0 | R/W-0 | R/W-0 | R/W-0 | R/W-0 | R/W-0 | R/W-0 |
| | RADDR<7:0> | | | | | | | |

Legend:

R = Readable bit

W = Writable bit

U = Unimplemented bit, read as '0'

-n = Value at POR

'1' = Bit is set

'0' = Bit is cleared

x = Bit is unknown

bit 31-16 **Unimplemented:** Read as '0'

bit 15 **RCS2:** Chip Select 2 bit⁽¹⁾

1 = Chip Select 2 is active

0 = Chip Select 2 is inactive (RADDR15 function is selected)

bit 15 **RADDR<15>:** Target Address bit 15⁽²⁾

bit 14 **RCS1:** Chip Select 1 bit⁽³⁾

1 = Chip Select 1 is active

0 = Chip Select 1 is inactive (RADDR14 function is selected)

bit 14 **RADDR<14>:** Target Address bit 14⁽⁴⁾

bit 13-0 **RADDR<13:0>:** Address bits

Note 1: When the CSF<1:0> bits (PMCON<7:6>) = 10 or 01.

2: When the CSF<1:0> bits (PMCON<7:6>) = 00.

3: When the CSF<1:0> bits (PMCON<7:6>) = 10.

4: When the CSF<1:0> bits (PMCON<7:6>) = 00 or 01.

Note: This register is only used when the DUALBUF bit (PMCON<17>) is set to '1'.

PIC32MZ Embedded Connectivity with Floating Point Unit (EF) Family

REGISTER 23-10: PMRDIN: PARALLEL PORT READ INPUT DATA REGISTER

| Bit Range | Bit 31/23/15/7 | Bit 30/22/14/6 | Bit 29/21/13/5 | Bit 28/20/12/4 | Bit 27/19/11/3 | Bit 26/18/10/2 | Bit 25/17/9/1 | Bit 24/16/8/0 |
|-----------|----------------|----------------|----------------|----------------|----------------|----------------|---------------|---------------|
| 31:24 | U-0 | U-0 | U-0 | U-0 | U-0 | U-0 | U-0 | U-0 |
| | — | — | — | — | — | — | — | — |
| 23:16 | U-0 | U-0 | U-0 | U-0 | U-0 | U-0 | U-0 | U-0 |
| | — | — | — | — | — | — | — | — |
| 15:8 | R/W-0 | R/W-0 | R/W-0 | R/W-0 | R/W-0 | R/W-0 | R/W-0 | R/W-0 |
| | RDATAIN<15:8> | | | | | | | |
| 7:0 | R/W-0 | R/W-0 | R/W-0 | R/W-0 | R/W-0 | R/W-0 | R/W-0 | R/W-0 |
| | RDATAIN<7:0> | | | | | | | |

Legend:

R = Readable bit

W = Writable bit

U = Unimplemented bit, read as '0'

-n = Value at POR

'1' = Bit is set

'0' = Bit is cleared

x = Bit is unknown

bit 31-16 **Unimplemented:** Read as '0'

bit 15-0 **RDATAIN<15:0>:** Port Read Input Data bits

Note: This register is only used when the DUALBUF bit (PMCON<17>) is set to '1' and exclusively for reads. If the DUALBUF bit is '0', the PMDIN register ([Register 23-5](#)) is used for reads instead of PMRDIN.

PIC32MZ Embedded Connectivity with Floating Point Unit (EF) Family

NOTES:

24.0 EXTERNAL BUS INTERFACE (EBI)

Note: This data sheet summarizes the features of the PIC32MZ EF family of devices. It is not intended to be a comprehensive reference source. To complement the information in this data sheet, refer to **Section 47. “External Bus Interface (EBI)”** in the “*PIC32 Family Reference Manual*”, which is available from the Microchip web site (www.microchip.com/PIC32).

The External Bus Interface (EBI) module provides a high-speed, convenient way to interface external parallel memory devices to the PIC32MZ EF family device.

With the EBI module, it is possible to connect asynchronous SRAM and NOR Flash devices, as well as non-memory devices such as camera sensors and LCDs.

The features of the EBI module depend on the pin count of the PIC32MZ EF device, as shown in [Table 24-1](#).

Note: The EBI module is not available on 64-pin devices.

TABLE 24-1: EBI MODULE FEATURES

| Feature | Number of Device Pins | | |
|---------------------------|-----------------------|-----|-----|
| | 100 | 124 | 144 |
| Async SRAM | Y | Y | Y |
| Async NOR Flash | Y | Y | Y |
| Available address lines | 20 | 20 | 24 |
| 8-bit data bus support | Y | Y | Y |
| 16-bit data bus support | Y | Y | Y |
| Available Chip Selects | 1 | 1 | 4 |
| Timing mode sets | 3 | 3 | 3 |
| 8-bit R/W from 16-bit bus | N | N | Y |
| Non-memory device | Y | Y | Y |
| LCD | Y | Y | Y |

Note: Once the EBI module is configured, external devices will be memory mapped and can be access from KSEG2 memory space (see [Figure 4-1](#) through [Figure 4-4](#) in [Section 4.0 “Memory Organization”](#) for more information). The MMU must be enabled and the TLB must be set up to access this memory (refer to [Section 50. “CPU for Devices with MIPS32® microAptiv™ and M-Class Cores”](#) (DS60001192) of the “*PIC32 Family Reference Manual*” for more information).

FIGURE 24-1: EBI SYSTEM BLOCK DIAGRAM

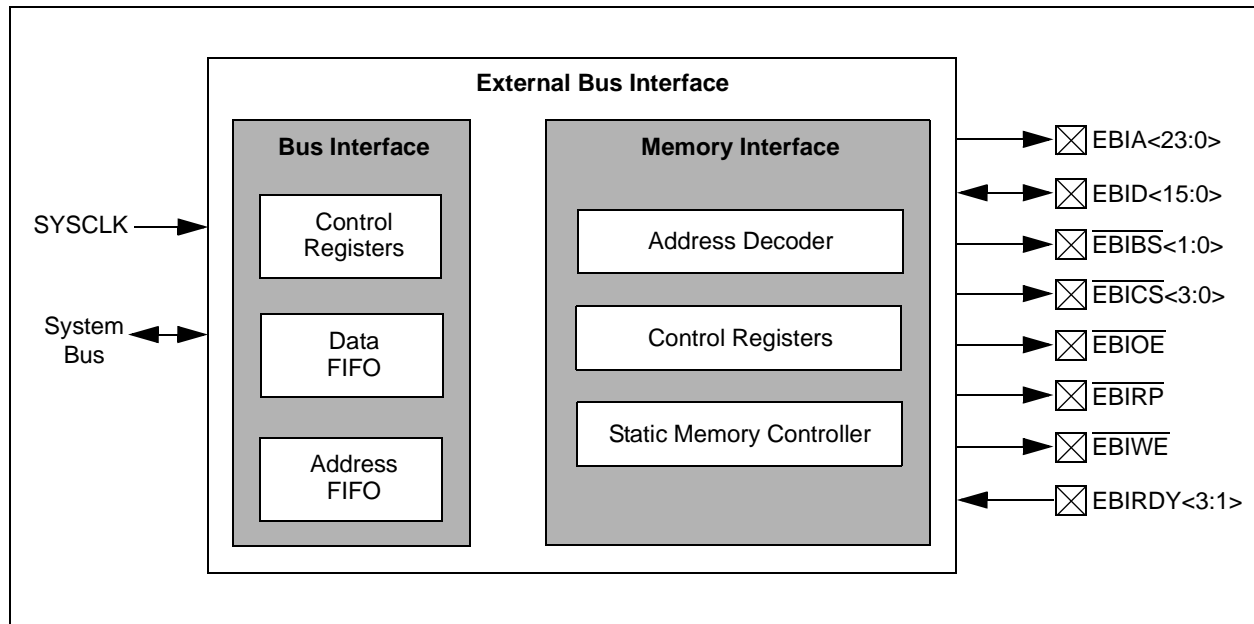

24.1 EBI Control Registers

TABLE 24-2: EBI REGISTER MAP

| Virtual Address (BF8E_#) | Register Name | Bit Range | Bits | | | | | | | | | | | | | | | All Resets | |
|-----------------------------|------------------------|-----------|--------------|-------|-------|-------|-------|----------------|----------------|----------------|-----------|------|------|------|------|------|------|------------|-----------|
| | | | 31/15 | 30/14 | 29/13 | 28/12 | 27/11 | 26/10 | 25/9 | 24/8 | 23/7 | 22/6 | 21/5 | 20/4 | 19/3 | 18/2 | 17/1 | | 16/0 |
| 1014 | EBICS0 | 31:16 | CSADDR<15:0> | | | | | | | | | | | | | | | 0000 | |
| | | 15:0 | — | — | — | — | — | — | — | — | — | — | — | — | — | — | — | — | 0000 |
| 1018 | EBICS1 ⁽¹⁾ | 31:16 | CSADDR<15:0> | | | | | | | | | | | | | | | 0000 | |
| | | 15:0 | — | — | — | — | — | — | — | — | — | — | — | — | — | — | — | — | 0000 |
| 101C | EBICS2 ⁽¹⁾ | 31:16 | CSADDR<15:0> | | | | | | | | | | | | | | | 0000 | |
| | | 15:0 | — | — | — | — | — | — | — | — | — | — | — | — | — | — | — | — | 0000 |
| 1020 | EBICS3 ⁽¹⁾ | 31:16 | CSADDR<15:0> | | | | | | | | | | | | | | | 0000 | |
| | | 15:0 | — | — | — | — | — | — | — | — | — | — | — | — | — | — | — | — | 0000 |
| 1054 | EBIMSK0 | 31:16 | — | — | — | — | — | — | — | — | — | — | — | — | — | — | — | — | 0000 |
| | | 15:0 | — | — | — | — | — | REGSEL<2:0> | MEMTYPE<2:0> | MEMSIZE<4:0> | — | — | — | — | — | — | — | — | 0020 |
| 1058 | EBIMSK1 ⁽¹⁾ | 31:16 | — | — | — | — | — | — | — | — | — | — | — | — | — | — | — | — | 0000 |
| | | 15:0 | — | — | — | — | — | REGSEL<2:0> | MEMTYPE<2:0> | MEMSIZE<4:0> | — | — | — | — | — | — | — | — | 0020 |
| 105C | EBIMSK2 ⁽¹⁾ | 31:16 | — | — | — | — | — | — | — | — | — | — | — | — | — | — | — | — | 0000 |
| | | 15:0 | — | — | — | — | — | REGSEL<2:0> | MEMTYPE<2:0> | MEMSIZE<4:0> | — | — | — | — | — | — | — | — | 0120 |
| 1060 | EBIMSK3 ⁽¹⁾ | 31:16 | — | — | — | — | — | — | — | — | — | — | — | — | — | — | — | — | 0000 |
| | | 15:0 | — | — | — | — | — | REGSEL<2:0> | MEMTYPE<2:0> | MEMSIZE<4:0> | — | — | — | — | — | — | — | — | 0120 |
| 1094 | EBISMT0 | 31:16 | — | — | — | — | — | RDYMODE | PAGESIZE<1:0> | PAGEMODE | TPRC<3:0> | — | — | — | — | — | — | TBTA<2:0> | 041C |
| | | 15:0 | — | — | — | — | — | TWP<5:0> | TWR<1:0> | TAS<1:0> | TRC<5:0> | — | — | — | — | — | — | — | 2D4B |
| 1098 | EBISMT1 | 31:16 | — | — | — | — | — | RDYMODE | PAGESIZE<1:0> | PAGEMODE | TPRC<3:0> | — | — | — | — | — | — | TBTA<2:0> | 041C |
| | | 15:0 | — | — | — | — | — | TWP<5:0> | TWR<1:0> | TAS<1:0> | TRC<5:0> | — | — | — | — | — | — | — | 2D4B |
| 109C | EBISMT2 | 31:16 | — | — | — | — | — | RDYMODE | PAGESIZE<1:0> | PAGEMODE | TPRC<3:0> | — | — | — | — | — | — | TBTA<2:0> | 014C |
| | | 15:0 | — | — | — | — | — | TWP<5:0> | TWR<1:0> | TAS<1:0> | TRC<5:0> | — | — | — | — | — | — | — | 2D4B |
| 10A0 | EBIFTRPD | 31:16 | — | — | — | — | — | — | — | — | — | — | — | — | — | — | — | — | 0000 |
| | | 15:0 | — | — | — | — | — | — | — | — | — | — | — | — | — | — | — | — | 00C8 |
| 10A4 | EBISMCON | 31:16 | — | — | — | — | — | — | — | — | — | — | — | — | — | — | — | — | 0000 |
| | | 15:0 | — | — | — | — | — | SMDWIDTH2<2:0> | SMDWIDTH1<2:0> | SMDWIDTH0<2:0> | — | — | — | — | — | — | — | — | SMRP 0201 |

Legend: x = unknown value on Reset; — = unimplemented, read as '0'. Reset values are shown in hexadecimal.

Note 1: This register is available on 144-pin devices only.

PIC32MZ Embedded Connectivity with Floating Point Unit (EF) Family

REGISTER 24-1: EBICSx: EXTERNAL BUS INTERFACE CHIP SELECT REGISTER ('x' = 0-3)

| Bit Range | Bit 31/23/15/7 | Bit 30/22/14/6 | Bit 29/21/13/5 | Bit 28/20/12/4 | Bit 27/19/11/3 | Bit 26/18/10/2 | Bit 25/17/9/1 | Bit 24/16/8/0 |
|-----------|----------------|----------------|----------------|----------------|----------------|----------------|---------------|---------------|
| 31:24 | R/W-0 | R/W-0 | R/W-0 | R/W-0 | R/W-0 | R/W-0 | R/W-0 | R/W-0 |
| | CSADDR<15:8> | | | | | | | |
| 23:16 | R/W-0 | R/W-0 | R/W-0 | R/W-0 | R/W-0 | R/W-0 | R/W-0 | R/W-0 |
| | CSADDR<7:0> | | | | | | | |
| 15:8 | U-0 | U-0 | U-0 | U-0 | U-0 | U-0 | U-0 | U-0 |
| | — | — | — | — | — | — | — | — |
| 7:0 | U-0 | U-0 | U-0 | U-0 | U-0 | U-0 | U-0 | U-0 |
| | — | — | — | — | — | — | — | — |

Legend:

R = Readable bit

W = Writable bit

U = Unimplemented bit, read as '0'

-n = Value at POR

'1' = Bit is set

'0' = Bit is cleared

x = Bit is unknown

bit 31-16 **CSADDR<15:0>**: Base Address for Device bits

Address in physical memory, which will select the external device.

bit 15-0 **Unimplemented**: Read as '0'

PIC32MZ Embedded Connectivity with Floating Point Unit (EF) Family

REGISTER 24-2: EBIMSKx: EXTERNAL BUS INTERFACE ADDRESS MASK REGISTER ('x' = 0-3)

| Bit Range | Bit 31/23/15/7 | Bit 30/22/14/6 | Bit 29/21/13/5 | Bit 28/20/12/4 | Bit 27/19/11/3 | Bit 26/18/10/2 | Bit 25/17/9/1 | Bit 24/16/8/0 |
|-----------|----------------|----------------|----------------|-----------------------------|----------------|----------------|---------------|---------------|
| 31:24 | U-0 | U-0 | U-0 | U-0 | U-0 | U-0 | U-0 | U-0 |
| | — | — | — | — | — | — | — | — |
| 23:16 | U-0 | U-0 | U-0 | U-0 | U-0 | U-0 | U-0 | U-0 |
| | — | — | — | — | — | — | — | — |
| 15:8 | U-0 | U-0 | U-0 | U-0 | U-0 | R/W-0 | R/W-0 | R/W-0 |
| | — | — | — | — | — | REGSEL<2:0> | | |
| 7:0 | R/W-0 | R/W-0 | R/W-1 | R/W-0 | R/W-0 | R/W-0 | R/W-0 | R/W-0 |
| | MEMTYPE<2:0> | | | MEMSIZE<4:0> ⁽¹⁾ | | | | |

Legend:

R = Readable bit

W = Writable bit

U = Unimplemented bit, read as '0'

-n = Value at POR

'1' = Bit is set

'0' = Bit is cleared

x = Bit is unknown

bit 31-11 **Unimplemented:** Read as '0'

bit 10-8 **REGSEL<2:0>**: Timing Register Set for Chip Select 'x' bits

111 = Reserved

•
•
•

011 = Reserved

010 = Use EBISMT2

001 = Use EBISMT1

000 = Use EBISMT0

bit 7-5 **MEMTYPE<2:0>**: Select Memory Type for Chip Select 'x' bits

111 = Reserved

•
•
•

011 = Reserved

010 = NOR-Flash

001 = SRAM

000 = Reserved

bit 4-0 **MEMSIZE<4:0>**: Select Memory Size for Chip Select 'x' bits⁽¹⁾

11111 = Reserved

•
•
•

01010 = Reserved

01001 = 16 MB

01000 = 8 MB

00111 = 4 MB

00110 = 2 MB

00101 = 1 MB

00100 = 512 KB

00011 = 256 KB

00010 = 128 KB

00001 = 64 KB (smaller memories alias within this range)

00000 = Chip Select is not used

Note 1: The specified value for these bits depends on the number of available address lines. Refer to the specific device pin table (Table 2 through Table 5) for the available address lines.

PIC32MZ Embedded Connectivity with Floating Point Unit (EF) Family

REGISTER 24-3: EBISMTx: EXTERNAL BUS INTERFACE STATIC MEMORY TIMING REGISTER (‘x’ = 0-2)

| Bit Range | Bit 31/23/15/7 | Bit 30/22/14/6 | Bit 29/21/13/5 | Bit 28/20/12/4 | Bit 27/19/11/3 | Bit 26/18/10/2 | Bit 25/17/9/1 | Bit 24/16/8/0 |
|-----------|-------------------------|----------------|--------------------------|----------------|----------------|--------------------------|-------------------------|---------------|
| 31:24 | U-0 | U-0 | U-0 | U-0 | U-0 | R/W-1 | R/W-0 | R/W-0 |
| | — | — | — | — | — | RDYMODE | PAGESIZE<1:0> | |
| 23:16 | R/W-0 | R/W-0 | R/W-0 | R/W-1 | R/W-1 | R/W-1 | R/W-0 | R/W-0 |
| | PAGEMODE | | TPRC<3:0> ⁽¹⁾ | | | TBTA<2:0> ⁽¹⁾ | | |
| 15:8 | R/W-0 | R/W-0 | R/W-1 | R/W-0 | R/W-1 | R/W-1 | R/W-0 | R/W-1 |
| | TWP<5:0> ⁽¹⁾ | | | | | | TWR<1:0> ⁽¹⁾ | |
| 7:0 | R/W-0 | R/W-1 | R/W-0 | R/W-0 | R/W-1 | R/W-0 | R/W-1 | R/W-1 |
| | TAS<1:0> ⁽¹⁾ | | TRC<5:0> ⁽¹⁾ | | | | | |

Legend:

| | | |
|-------------------|------------------|--|
| R = Readable bit | W = Writable bit | U = Unimplemented bit, read as ‘0’ |
| -n = Value at POR | ‘1’ = Bit is set | ‘0’ = Bit is cleared x = Bit is unknown |

bit 31-27 **Unimplemented:** Read as ‘0’

bit 26 **RDYMODE:** Data Ready Device Select bit

The device associated with register set ‘x’ is a data-ready device, and will use the EBIRDYx pin.

1 = EBIRDYx input is used

0 = EBIRDYx input is not used

bit 25-24 **PAGESIZE<1:0>:** Page Size for Page Mode Device bits

11 = 32-word page

10 = 16-word page

01 = 8-word page

00 = 4-word page

bit 23 **PAGEMODE:** Memory Device Page Mode Support bit

1 = Device supports Page mode

0 = Device does not support Page mode

bit 22-19 **TPRC<3:0>:** Page Mode Read Cycle Time bits⁽¹⁾

Read cycle time is TPRC + 1 clock cycle.

bit 18-16 **TBTA<2:0>:** Data Bus Turnaround Time bits⁽¹⁾

Clock cycles (0-7) for static memory between read-to-write, write-to-read, and read-to-read when Chip Select changes.

bit 15-10 **TWP<5:0>:** Write Pulse Width bits⁽¹⁾

Write pulse width is TWP + 1 clock cycle.

bit 9-8 **TWR<1:0>:** Write Address/Data Hold Time bits⁽¹⁾

Number of clock cycles to hold address or data on the bus.

bit 7-6 **TAS<1:0>:** Write Address Setup Time bits⁽¹⁾

Clock cycles for address setup time. A value of ‘0’ is only valid in the case of SSRAM.

bit 5-0 **TRC<5:0>:** Read Cycle Time bits⁽¹⁾

Read cycle time is TRC + 1 clock cycle.

Note 1: Please refer to **Section 47. “External Bus Interface (EBI)”** in the *“PIC32 Family Reference Manual”* for the EBI timing diagrams and additional information.

PIC32MZ Embedded Connectivity with Floating Point Unit (EF) Family

REGISTER 24-4: EBIFTRPD: EXTERNAL BUS INTERFACE FLASH TIMING REGISTER

| Bit Range | Bit 31/23/15/7 | Bit 30/22/14/6 | Bit 29/21/13/5 | Bit 28/20/12/4 | Bit 27/19/11/3 | Bit 26/18/10/2 | Bit 25/17/9/1 | Bit 24/16/8/0 |
|-----------|----------------|----------------|----------------|----------------|----------------|----------------|---------------|---------------|
| 31:24 | U-0 | U-0 | U-0 | U-0 | U-0 | U-0 | U-0 | U-0 |
| | — | — | — | — | — | — | — | — |
| 23:16 | U-0 | U-0 | U-0 | U-0 | U-0 | U-0 | U-0 | U-0 |
| | — | — | — | — | — | — | — | — |
| 15:8 | U-0 | U-0 | U-0 | U-0 | R/W-0 | R/W-0 | R/W-0 | R/W-0 |
| | — | — | — | — | TRPD<11:8> | | | |
| 7:0 | R/W-0 | R/W-0 | R/W-0 | R/W-0 | R/W-0 | R/W-0 | R/W-0 | R/W-0 |
| | TRPD<7:0> | | | | | | | |

Legend:

R = Readable bit

W = Writable bit

U = Unimplemented bit, read as '0'

-n = Value at POR

'1' = Bit is set

'0' = Bit is cleared

x = Bit is unknown

bit 31-12 **Unimplemented:** Read as '0'

bit 11-0 **TRPD<11:0>:** Flash Timing bits

These bits define the number of clock cycles to wait after resetting the external Flash memory before any read/write access.

PIC32MZ Embedded Connectivity with Floating Point Unit (EF) Family

REGISTER 24-5: EBISMCON: EXTERNAL BUS INTERFACE STATIC MEMORY CONTROL REGISTER

| Bit Range | Bit 31/23/15/7 | Bit 30/22/14/6 | Bit 29/21/13/5 | Bit 28/20/12/4 | Bit 27/19/11/3 | Bit 26/18/10/2 | Bit 25/17/9/1 | Bit 24/16/8/0 |
|-----------|----------------|----------------|----------------|----------------|----------------|----------------|----------------|---------------|
| 31:24 | U-0 | U-0 | U-0 | U-0 | U-0 | U-0 | U-0 | U-0 |
| | — | — | — | — | — | — | — | — |
| 23:16 | U-0 | U-0 | U-0 | U-0 | U-0 | U-0 | U-0 | U-0 |
| | — | — | — | — | — | — | — | — |
| 15:8 | R/W-0 | R/W-0 | R/W-0 | R/W-0 | R/W-0 | R/W-0 | R/W-1 | R/W-0 |
| | SMDWIDTH2<2:0> | | | SMDWIDTH1<2:0> | | | SMDWIDTH0<2:1> | |
| 7:0 | R/W-0 | U-0 | U-0 | U-0 | U-0 | U-0 | U-0 | R/W-1 |
| | SMDWIDTH0<0> | — | — | — | — | — | — | SMRP |

Legend:

R = Readable bit
-n = Value at POR

W = Writable bit
'1' = Bit is set

U = Unimplemented bit, read as '0'
'0' = Bit is cleared
x = Bit is unknown

bit 31-16 **Unimplemented:** Read as '0'

bit 15-13 **SMDWIDTH2<2:0>**: Static Memory Width for Register EBISMT2 bits

111 = Reserved
110 = Reserved
101 = Reserved
100 = 8 bits
011 = Reserved
010 = Reserved
001 = Reserved
000 = 16 bits

bit 12-10 **SMDWIDTH1<2:0>**: Static Memory Width for Register EBISMT1 bits

111 = Reserved
110 = Reserved
101 = Reserved
100 = 8 bits
011 = Reserved
010 = Reserved
001 = Reserved
000 = 16 bits

bit 9-7 **SMDWIDTH0<2:0>**: Static Memory Width for Register EBISMT0 bits

111 = Reserved
110 = Reserved
101 = Reserved
100 = 8 bits
011 = Reserved
010 = Reserved
001 = Reserved
000 = 16 bits

bit 6-1 **Unimplemented:** Read as '0'

bit 0 **SMRP**: Flash Reset/Power-down mode Select bit

After a Reset, the controller internally performs a power-down for Flash, and then sets this bit to '1'.

1 = Flash is taken out of Power-down mode
0 = Flash is forced into Power-down mode

PIC32MZ Embedded Connectivity with Floating Point Unit (EF) Family

NOTES:

25.0 REAL-TIME CLOCK AND CALENDAR (RTCC)

Note: This data sheet summarizes the features of the PIC32MZ EF family of devices. It is not intended to be a comprehensive reference source. To complement the information in this data sheet, refer to **Section 29. “Real-Time Clock and Calendar (RTCC)”** (DS60001125) in the “PIC32 Family Reference Manual”, which is available from the Microchip web site (www.microchip.com/PIC32).

The RTCC module is intended for applications in which accurate time must be maintained for extended periods of time with minimal or no CPU intervention. Low-power optimization provides extended battery lifetime while keeping track of time.

Key features of the RTCC module include:

- Time: hours, minutes and seconds
- 24-hour format (military time)
- Visibility of one-half second period
- Provides calendar: Weekday, date, month and year
- Alarm intervals are configurable for half of a second, one second, 10 seconds, one minute, 10 minutes, one hour, one day, one week, one month, and one year
- Alarm repeat with decremting counter
- Alarm with indefinite repeat: Chime
- Year range: 2000 to 2099
- Leap year correction
- BCD format for smaller firmware overhead
- Optimized for long-term battery operation
- Fractional second synchronization
- User calibration of the clock crystal frequency with auto-adjust
- Calibration range: ± 0.66 seconds error per month
- Calibrates up to 260 ppm of crystal error
- Uses external 32.768 kHz crystal or 32 kHz internal oscillator
- Alarm pulse, seconds clock, or internal clock output on RTCC pin

FIGURE 25-1: RTCC BLOCK DIAGRAM

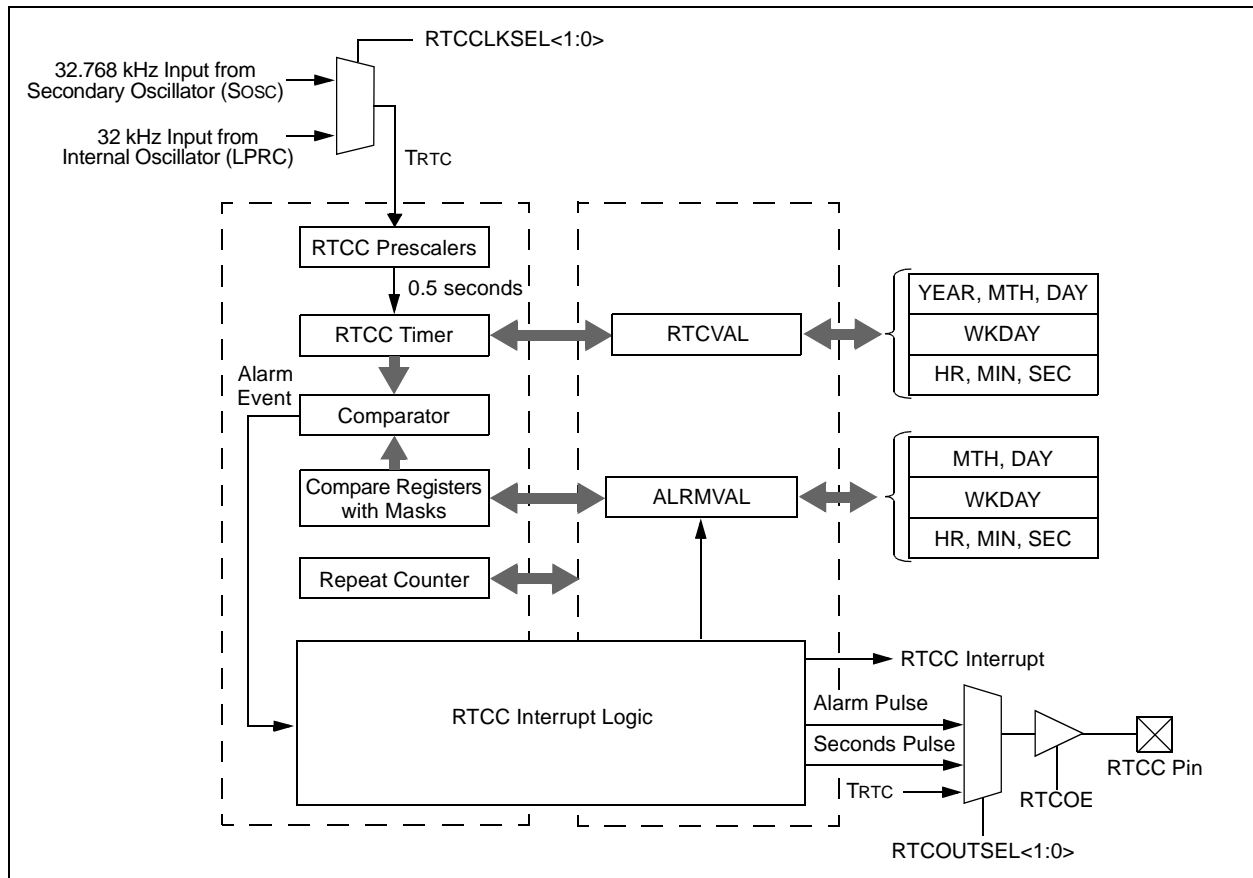

25.1 RTCC Control Registers

TABLE 25-1: RTCC REGISTER MAP

| Virtual Address (BF80_#) | Register Name ⁽¹⁾ | Bit Range | Bits | | | | | | | | | | | | | | | All Resets |
|-----------------------------|---------------------------------|-----------|-------------|-------|-------|----------|-------------|----------------|----------------|----------|--------------|-----------|------|------|--------------|---------|---------|------------|
| | | | 31/15 | 30/14 | 29/13 | 28/12 | 27/11 | 26/10 | 25/9 | 24/8 | 23/7 | 22/6 | 21/5 | 20/4 | 19/3 | 18/2 | 17/1 | |
| 0C00 | RTCCON | 31:16 | — | — | — | — | — | — | CAL<9:0> | | | | | | | | | 0000 |
| | | 15:0 | ON | — | SIDL | — | — | RTCCLKSEL<1:0> | RTCOUTSEL<1:0> | RTCCLKON | — | — | — | — | RTCWREN | RTCSYNC | HALFSEC | RTCOC |
| 0C10 | RTCALRM | 31:16 | — | — | — | — | — | — | — | — | — | — | — | — | — | — | — | 0000 |
| | | 15:0 | ALRMEN | CHIME | PIV | ALRMSYNC | AMASK<3:0> | | | | | ARPT<7:0> | | | | | 0000 | |
| 0C20 | RTCTIME | 31:16 | HR10<3:0> | | | | HR01<3:0> | | | | MIN10<3:0> | | | | MIN01<3:0> | | | xxxx |
| | | 15:0 | SEC10<3:0> | | | | SEC01<3:0> | | | | — | — | — | — | — | — | — | — |
| 0C30 | RTCDATE | 31:16 | YEAR10<3:0> | | | | YEAR01<3:0> | | | | MONTH10<3:0> | | | | MONTH01<3:0> | | | xxxx |
| | | 15:0 | DAY10<3:0> | | | | DAY01<3:0> | | | | — | — | — | — | WDAY01<3:0> | | | xxx0 |
| 0C40 | ALRMTIME | 31:16 | HR10<3:0> | | | | HR01<3:0> | | | | MIN10<3:0> | | | | MIN01<3:0> | | | xxxx |
| | | 15:0 | SEC10<3:0> | | | | SEC01<3:0> | | | | — | — | — | — | — | — | — | — |
| 0C50 | ALRMDATE | 31:16 | — | — | — | — | — | — | — | — | MONTH10<3:0> | | | | MONTH01<3:0> | | | 00xx |
| | | 15:0 | DAY10<3:0> | | | | DAY01<3:0> | | | | — | — | — | — | WDAY01<3:0> | | | xxx0x |

Legend: x = unknown value on Reset; — = unimplemented, read as '0'. Reset values are shown in hexadecimal.

Note 1: All registers in this table have corresponding CLR, SET and INV registers at its virtual address, plus an offset of 0x4, 0x8 and 0xC, respectively. See [Section 12.3 "CLR, SET, and INV Registers"](#) for more information.

PIC32MZ Embedded Connectivity with Floating Point Unit (EF) Family

REGISTER 25-1: RTCCON: REAL-TIME CLOCK AND CALENDAR CONTROL REGISTER

bit 10-9 **RTCCLKSEL<1:0>**: RTCC Clock Select bits

When a new value is written to these bits, the Seconds Value register should also be written to properly reset the clock prescalers in the RTCC.

11 = Reserved

10 = Reserved

01 = RTCC uses the external 32.768 kHz Secondary Oscillator (SOSC)

00 = RTCC uses the internal 32 kHz oscillator (LPRC)

bit 8-7 **RTCOUTSEL<1:0>**: RTCC Output Data Select bits⁽²⁾

11 = Reserved

10 = RTCC Clock is presented on the RTCC pin

01 = Seconds Clock is presented on the RTCC pin

00 = Alarm Pulse is presented on the RTCC pin when the alarm interrupt is triggered

bit 6 **RTCCLKON**: RTCC Clock Enable Status bit⁽⁵⁾

1 = RTCC Clock is actively running

0 = RTCC Clock is not running

bit 5-4 **Unimplemented**: Read as '0'

bit 3 **RTCWREN**: Real-Time Clock Value Registers Write Enable bit⁽³⁾

1 = Real-Time Clock Value registers can be written to by the user

0 = Real-Time Clock Value registers are locked out from being written to by the user

bit 2 **RTCSYNC**: Real-Time Clock Value Registers Read Synchronization bit

1 = Real-time clock value registers can change while reading (due to a rollover ripple that results in an invalid data read). If the register is read twice and results in the same data, the data can be assumed to be valid.

0 = Real-time clock value registers can be read without concern about a rollover ripple

bit 1 **HALFSEC**: Half-Second Status bit⁽⁴⁾

1 = Second half period of a second

0 = First half period of a second

bit 0 **RTC OE**: RTCC Output Enable bit

1 = RTCC output is enabled

0 = RTCC output is not enabled

Note 1: The ON bit is only writable when RTCWREN = 1.

2: Requires RTCOE = 1 (RTCCON<0>) for the output to be active.

3: The RTCWREN bit can be set only when the write sequence is enabled.

4: This bit is read-only. It is cleared to '0' on a write to the seconds bit fields (RTCTIME<14:8>).

5: This bit is undefined when RTCCLKSEL<1:0> = 00 (LPRC is the clock source).

Note: This register is reset only on a Power-on Reset (POR).

PIC32MZ Embedded Connectivity with Floating Point Unit (EF) Family

REGISTER 25-2: RTCALRM: REAL-TIME CLOCK ALARM CONTROL REGISTER

| Bit Range | Bit 31/23/15/7 | Bit 30/22/14/6 | Bit 29/21/13/5 | Bit 28/20/12/4 | Bit 27/19/11/3 | Bit 26/18/10/2 | Bit 25/17/9/1 | Bit 24/16/8/0 |
|-----------|--------------------------|----------------------|--------------------|----------------|---------------------------|----------------|---------------|---------------|
| 31:24 | U-0 — | U-0 — | U-0 — | U-0 — | U-0 — | U-0 — | U-0 — | U-0 — |
| 23:16 | U-0 — | U-0 — | U-0 — | U-0 — | U-0 — | U-0 — | U-0 — | U-0 — |
| 15:8 | R/W-0 | R/W-0 | R/W-0 | R-0 | R/W-0 | R/W-0 | R/W-0 | R/W-0 |
| | ALRMEN ^(1,2) | CHIME ⁽²⁾ | PIV ⁽²⁾ | ALRMSYNC | AMASK<3:0> ⁽²⁾ | | | |
| 7:0 | R/W-0 | R/W-0 | R/W-0 | R/W-0 | R/W-0 | R/W-0 | R/W-0 | R/W-0 |
| | ARPT<7:0> ⁽²⁾ | | | | | | | |

Legend:

R = Readable bit
-n = Value at POR

W = Writable bit
'1' = Bit is set

U = Unimplemented bit, read as '0'
'0' = Bit is cleared
x = Bit is unknown

bit 31-16 **Unimplemented:** Read as '0'
bit 15 **ALRMEN:** Alarm Enable bit^(1,2)

1 = Alarm is enabled
0 = Alarm is disabled

bit 14 **CHIME:** Chime Enable bit⁽²⁾

1 = Chime is enabled – ARPT<7:0> is allowed to rollover from 0x00 to 0xFF
0 = Chime is disabled – ARPT<7:0> stops once it reaches 0x00

bit 13 **PIV:** Alarm Pulse Initial Value bit⁽²⁾

When ALRMEN = 0, PIV is writable and determines the initial value of the Alarm Pulse.
When ALRMEN = 1, PIV is read-only and returns the state of the Alarm Pulse.

bit 12 **ALRMSYNC:** Alarm Sync bit

1 = ARPT<7:0> and ALRMEN may change as a result of a half second rollover during a read.
The ARPT must be read repeatedly until the same value is read twice. This must be done since multiple bits may be changing.
0 = ARPT<7:0> and ALRMEN can be read without concerns of rollover because the prescaler is more than 32 real-time clocks away from a half-second rollover

bit 11-8 **AMASK<3:0>:** Alarm Mask Configuration bits⁽²⁾

0000 = Every half-second
0001 = Every second
0010 = Every 10 seconds
0011 = Every minute
0100 = Every 10 minutes
0101 = Every hour
0110 = Once a day
0111 = Once a week
1000 = Once a month
1001 = Once a year (except when configured for February 29, once every four years)
1010 = Reserved
1011 = Reserved
11xx = Reserved

Note 1: Hardware clears the ALRMEN bit anytime the alarm event occurs, when ARPT<7:0> = 00 and CHIME = 0.

Note 2: This field should not be written when the RTCC ON bit = '1' (RTCCON<15>) and ALRMSYNC = 1.

Note: This register is reset only on a Power-on Reset (POR).

PIC32MZ Embedded Connectivity with Floating Point Unit (EF) Family

REGISTER 25-2: RTCALRM: REAL-TIME CLOCK ALARM CONTROL REGISTER (CONTINUED)

bit 7-0 **ARPT<7:0>**: Alarm Repeat Counter Value bits⁽²⁾

11111111 = Alarm will trigger 256 times

•
•
•

00000000 = Alarm will trigger one time

The counter decrements on any alarm event. The counter only rolls over from 0x00 to 0xFF if CHIME = 1.

- Note 1:** Hardware clears the ALRMEN bit anytime the alarm event occurs, when ARPT<7:0> = 00 and CHIME = 0.
- 2:** This field should not be written when the RTCC ON bit = '1' (RTCCON<15>) and ALRMSYNC = 1.

| |
|---|
| Note: This register is reset only on a Power-on Reset (POR). |
|---|

PIC32MZ Embedded Connectivity with Floating Point Unit (EF) Family

REGISTER 25-3: RTCTIME: REAL-TIME CLOCK TIME VALUE REGISTER

| Bit Range | Bit 31/23/15/7 | Bit 30/22/14/6 | Bit 29/21/13/5 | Bit 28/20/12/4 | Bit 27/19/11/3 | Bit 26/18/10/2 | Bit 25/17/9/1 | Bit 24/16/8/0 |
|-----------|----------------|----------------|----------------|----------------|----------------|----------------|---------------|---------------|
| 31:24 | R/W-x | R/W-x | R/W-x | R/W-x | R/W-x | R/W-x | R/W-x | R/W-x |
| | HR10<3:0> | | | | HR01<3:0> | | | |
| 23:16 | R/W-x | R/W-x | R/W-x | R/W-x | R/W-x | R/W-x | R/W-x | R/W-x |
| | MIN10<3:0> | | | | MIN01<3:0> | | | |
| 15:8 | R/W-x | R/W-x | R/W-x | R/W-x | R/W-x | R/W-x | R/W-x | R/W-x |
| | SEC10<3:0> | | | | SEC01<3:0> | | | |
| 7:0 | U-0 | U-0 | U-0 | U-0 | U-0 | U-0 | U-0 | U-0 |
| | — | — | — | — | — | — | — | — |

Legend:

R = Readable bit
-n = Value at POR

W = Writable bit
'1' = Bit is set

U = Unimplemented bit, read as '0'
'0' = Bit is cleared
x = Bit is unknown

- bit 31-28 **HR10<3:0>**: Binary-Coded Decimal Value of Hours bits, 10 digits; contains a value from 0 to 2
- bit 27-24 **HR01<3:0>**: Binary-Coded Decimal Value of Hours bits, 1 digit; contains a value from 0 to 9
- bit 23-20 **MIN10<3:0>**: Binary-Coded Decimal Value of Minutes bits, 10 digits; contains a value from 0 to 5
- bit 19-16 **MIN01<3:0>**: Binary-Coded Decimal Value of Minutes bits, 1 digit; contains a value from 0 to 9
- bit 15-12 **SEC10<3:0>**: Binary-Coded Decimal Value of Seconds bits, 10 digits; contains a value from 0 to 5
- bit 11-8 **SEC01<3:0>**: Binary-Coded Decimal Value of Seconds bits, 1 digit; contains a value from 0 to 9
- bit 7-0 **Unimplemented**: Read as '0'

Note: This register is only writable when RTCWREN = 1 (RTCCON<3>).

PIC32MZ Embedded Connectivity with Floating Point Unit (EF) Family

REGISTER 25-4: RTCDATE: REAL-TIME CLOCK DATE VALUE REGISTER

| Bit Range | Bit 31/23/15/7 | Bit 30/22/14/6 | Bit 29/21/13/5 | Bit 28/20/12/4 | Bit 27/19/11/3 | Bit 26/18/10/2 | Bit 25/17/9/1 | Bit 24/16/8/0 |
|-----------|----------------|----------------|----------------|----------------|----------------|----------------|---------------|---------------|
| 31:24 | R/W-x | R/W-x | R/W-x | R/W-x | R/W-x | R/W-x | R/W-x | R/W-x |
| | YEAR10<3:0> | | | | YEAR01<3:0> | | | |
| 23:16 | R/W-x | R/W-x | R/W-x | R/W-x | R/W-x | R/W-x | R/W-x | R/W-x |
| | MONTH10<3:0> | | | | MONTH01<3:0> | | | |
| 15:8 | R/W-x | R/W-x | R/W-x | R/W-x | R/W-x | R/W-x | R/W-x | R/W-x |
| | DAY10<3:0> | | | | DAY01<3:0> | | | |
| 7:0 | U-0 | U-0 | U-0 | U-0 | R/W-x | R/W-x | R/W-x | R/W-x |
| | — | — | — | — | WDAY01<3:0> | | | |

Legend:

R = Readable bit

W = Writable bit

U = Unimplemented bit, read as '0'

-n = Value at POR

'1' = Bit is set

'0' = Bit is cleared

x = Bit is unknown

bit 31-28 **YEAR10<3:0>**: Binary-Coded Decimal Value of Years bits, 10 digits

bit 27-24 **YEAR01<3:0>**: Binary-Coded Decimal Value of Years bits, 1 digit

bit 23-20 **MONTH10<3:0>**: Binary-Coded Decimal Value of Months bits, 10 digits; contains a value from 0 to 1

bit 19-16 **MONTH01<3:0>**: Binary-Coded Decimal Value of Months bits, 1 digit; contains a value from 0 to 9

bit 15-12 **DAY10<3:0>**: Binary-Coded Decimal Value of Days bits, 10 digits; contains a value from 0 to 3

bit 11-8 **DAY01<3:0>**: Binary-Coded Decimal Value of Days bits, 1 digit; contains a value from 0 to 9

bit 7-4 **Unimplemented**: Read as '0'

bit 3-0 **WDAY01<3:0>**: Binary-Coded Decimal Value of Weekdays bits, 1 digit; contains a value from 0 to 6

Note: This register is only writable when $RTCWREN = 1$ ($RTCCON<3>$).

PIC32MZ Embedded Connectivity with Floating Point Unit (EF) Family

REGISTER 25-5: ALRMTIME: ALARM TIME VALUE REGISTER

| Bit Range | Bit 31/23/15/7 | Bit 30/22/14/6 | Bit 29/21/13/5 | Bit 28/20/12/4 | Bit 27/19/11/3 | Bit 26/18/10/2 | Bit 25/17/9/1 | Bit 24/16/8/0 |
|-----------|----------------|----------------|----------------|----------------|----------------|----------------|---------------|---------------|
| 31:24 | R/W-x | R/W-x | R/W-x | R/W-x | R/W-x | R/W-x | R/W-x | R/W-x |
| | HR10<3:0> | | | | HR01<3:0> | | | |
| 23:16 | R/W-x | R/W-x | R/W-x | R/W-x | R/W-x | R/W-x | R/W-x | R/W-x |
| | MIN10<3:0> | | | | MIN01<3:0> | | | |
| 15:8 | R/W-x | R/W-x | R/W-x | R/W-x | R/W-x | R/W-x | R/W-x | R/W-x |
| | SEC10<3:0> | | | | SEC01<3:0> | | | |
| 7:0 | U-0 | U-0 | U-0 | U-0 | U-0 | U-0 | U-0 | U-0 |
| | — | — | — | — | — | — | — | — |

Legend:

R = Readable bit
-n = Value at POR

W = Writable bit
'1' = Bit is set

U = Unimplemented bit, read as '0'
'0' = Bit is cleared
x = Bit is unknown

bit 31-28 **HR10<3:0>**: Binary Coded Decimal value of hours bits, 10 digits; contains a value from 0 to 2

bit 27-24 **HR01<3:0>**: Binary Coded Decimal value of hours bits, 1 digit; contains a value from 0 to 9

bit 23-20 **MIN10<3:0>**: Binary Coded Decimal value of minutes bits, 10 digits; contains a value from 0 to 5

bit 19-16 **MIN01<3:0>**: Binary Coded Decimal value of minutes bits, 1 digit; contains a value from 0 to 9

bit 15-12 **SEC10<3:0>**: Binary Coded Decimal value of seconds bits, 10 digits; contains a value from 0 to 5

bit 11-8 **SEC01<3:0>**: Binary Coded Decimal value of seconds bits, 1 digit; contains a value from 0 to 9

bit 7-0 **Unimplemented**: Read as '0'

PIC32MZ Embedded Connectivity with Floating Point Unit (EF) Family

REGISTER 25-6: ALRMDATE: ALARM DATE VALUE REGISTER

| Bit Range | Bit 31/23/15/7 | Bit 30/22/14/6 | Bit 29/21/13/5 | Bit 28/20/12/4 | Bit 27/19/11/3 | Bit 26/18/10/2 | Bit 25/17/9/1 | Bit 24/16/8/0 |
|-----------|----------------|----------------|----------------|----------------|----------------|----------------|---------------|---------------|
| 31:24 | U-0 | U-0 | U-0 | U-0 | U-0 | U-0 | U-0 | U-0 |
| | — | — | — | — | — | — | — | — |
| 23:16 | R/W-x | R/W-x | R/W-x | R/W-x | R/W-x | R/W-x | R/W-x | R/W-x |
| | MONTH10<3:0> | | | | MONTH01<3:0> | | | |
| 15:8 | R/W-x | R/W-x | R/W-x | R/W-x | R/W-x | R/W-x | R/W-x | R/W-x |
| | DAY10<1:0> | | | | DAY01<3:0> | | | |
| 7:0 | U-0 | U-0 | U-0 | U-0 | R/W-x | R/W-x | R/W-x | R/W-x |
| | — | — | — | — | WDAY01<3:0> | | | |

Legend:

R = Readable bit

W = Writable bit

U = Unimplemented bit, read as '0'

-n = Value at POR

'1' = Bit is set

'0' = Bit is cleared

x = Bit is unknown

bit 31-24 **Unimplemented:** Read as '0'

bit 23-20 **MONTH10<3:0>:** Binary Coded Decimal value of months bits, 10 digits; contains a value from 0 to 1

bit 19-16 **MONTH01<3:0>:** Binary Coded Decimal value of months bits, 1 digit; contains a value from 0 to 9

bit 15-12 **DAY10<3:0>:** Binary Coded Decimal value of days bits, 10 digits; contains a value from 0 to 3

bit 11-8 **DAY01<3:0>:** Binary Coded Decimal value of days bits, 1 digit; contains a value from 0 to 9

bit 7-4 **Unimplemented:** Read as '0'

bit 3-0 **WDAY01<3:0>:** Binary Coded Decimal value of weekdays bits, 1 digit; contains a value from 0 to 6

26.0 CRYPTO ENGINE

Note: This data sheet summarizes the features of the PIC32MZ EF family of devices. It is not intended to be a comprehensive reference source. To complement the information in this data sheet, refer to **Section 49. “Crypto Engine (CE) and Random Number Generator (RNG)”** (DS60001246) in the “PIC32 Family Reference Manual”, which is available from the Microchip web site (www.microchip.com/PIC32).

The Crypto Engine is intended to accelerate applications that need cryptographic functions. By executing these functions in the hardware module, software overhead is reduced, and actions such as encryption, decryption, and authentication can execute much more quickly.

The Crypto Engine uses an internal descriptor-based DMA for efficient programming of the security association data and packet pointers (allowing scatter/gather data fetching). An intelligent state machine schedules the Crypto Engines based on the protocol selection and packet boundaries. The hardware engines can perform the encryption and authentication in sequence or in parallel.

Key features of the Crypto Engine are:

- Bulk ciphers and hash engines
- Integrated DMA to off-load processing:
 - Buffer descriptor-based
 - Secure association per buffer descriptor
- Some functions can execute in parallel

Bulk ciphers that are handled by the Crypto Engine include:

- AES:
 - 128-bit, 192-bit, and 256-bit key sizes
 - CBC, ECB, CTR, CFB, and OFB modes
- DES/TDES:
 - CBC, ECB, CFB, and OFB modes

Authentication engines that are available through the Crypto Engine include:

- SHA-1
- SHA-256
- MD-5
- AES-GCM
- HMAC operation (for all authentication engines)

The rate of data that can be processed by the Crypto Engine depends on a number of factors, including:

- Which engine is in use
- Whether the engines are used in parallel or in series
- The demands on source and destination memories by other parts of the system (i.e., CPU, DMA, etc.)
- The speed of PBCLK5, which drives the Crypto Engine

Table 26-1 shows typical performance for various engines.

TABLE 26-1: CRYPTO ENGINE PERFORMANCE

| Engine/Algorithm | Performance Factor (Mbps/MHz) | Maximum Mbps (PBCLK5 = 100 MHz) |
|------------------|-------------------------------|---------------------------------|
| DES | 14.4 | 1440 |
| TDES | 6.6 | 660 |
| AES-128 | 9.0 | 900 |
| AES-192 | 7.9 | 790 |
| AES-256 | 7.2 | 720 |
| MD5 | 15.6 | 1560 |
| SHA-1 | 13.2 | 1320 |
| SHA-256 | 9.3 | 930 |

FIGURE 26-1: CRYPTO ENGINE BLOCK DIAGRAM

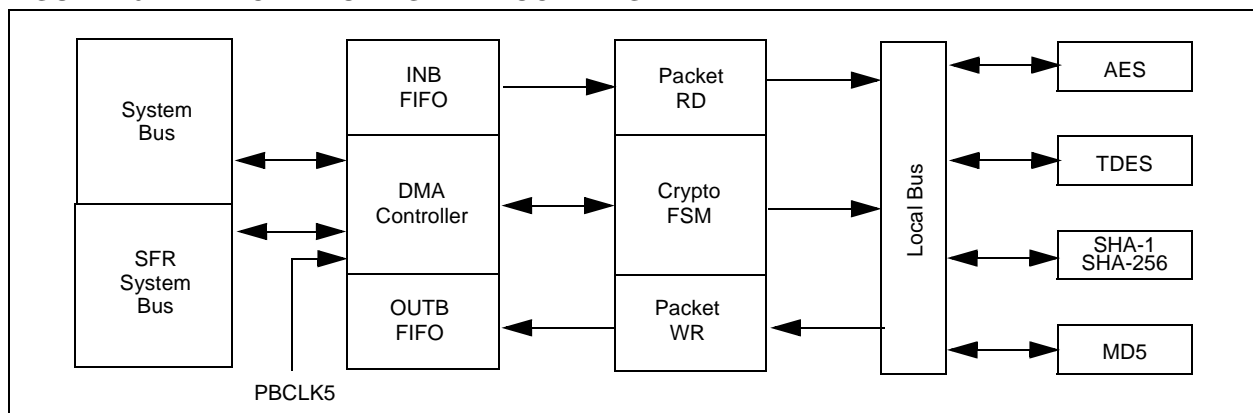

26.1 Crypto Engine Control Registers

TABLE 26-2: CRYPTO ENGINE REGISTER MAP

| Virtual Address (BF8E.#) | Register Name | Bit Range | Bits | | | | | | | | | | | | | | All Resets | | |
|-----------------------------|------------------|-----------|----------------|-------|------------|-------|-------|---------------|------|--------------|--------------|--------------|--------|------|-------|---------|------------|--------|------|
| | | | 31/15 | 30/14 | 29/13 | 28/12 | 27/11 | 26/10 | 25/9 | 24/8 | 23/7 | 22/6 | 21/5 | 20/4 | 19/3 | 18/2 | | 17/1 | 16/0 |
| 5000 | CEVER | 31:16 | REVISION<7:0> | | | | | | | VERSION<7:0> | | | | | | | 0000 | | |
| | | 15:0 | ID<15:0> | | | | | | | | | | | | | | 0000 | | |
| 5004 | CECON | 31:16 | — | — | — | — | — | — | — | — | — | — | — | — | — | — | — | — | 0000 |
| | | 15:0 | — | — | — | — | — | — | — | — | SWAPOEN | SWRST | SWAPEN | — | — | BDPCHST | BDPPLEN | DMAEN | 0000 |
| 5008 | CEBDADDR | 31:16 | BDPADDR<31:0> | | | | | | | | | | | | | | 0000 | | |
| | | 15:0 | | | | | | | | | | | | | | | 0000 | | |
| 500C | CEBDPADDR | 31:16 | BASEADDR<31:0> | | | | | | | | | | | | | | 0000 | | |
| | | 15:0 | | | | | | | | | | | | | | | 0000 | | |
| 5010 | CESTAT | 31:16 | ERRMODE<2:0> | | ERROP<2:0> | | | ERRPHASE<1:0> | | — | — | BDSTATE<3:0> | | | START | ACTIVE | 0000 | | |
| | | 15:0 | BDCTRL<15:0> | | | | | | | | | | | | | | 0000 | | |
| 5014 | CEINTSRC | 31:16 | — | — | — | — | — | — | — | — | — | — | — | — | — | — | — | 0000 | |
| | | 15:0 | — | — | — | — | — | — | — | — | — | — | — | — | AREIF | PKTIF | CBDIF | PENDIF | 0000 |
| 5018 | CEINTEN | 31:16 | — | — | — | — | — | — | — | — | — | — | — | — | — | — | — | 0000 | |
| | | 15:0 | — | — | — | — | — | — | — | — | — | — | — | — | AREIE | PKTIE | CBDIE | PENDIE | 0000 |
| 501C | CEPOLLCON | 31:16 | — | — | — | — | — | — | — | — | — | — | — | — | — | — | — | 0000 | |
| | | 15:0 | BDPPLCON<15:0> | | | | | | | | | | | | | | 0000 | | |
| 5020 | CEHDLEN | 31:16 | — | — | — | — | — | — | — | — | — | — | — | — | — | — | — | 0000 | |
| | | 15:0 | — | — | — | — | — | — | — | — | HDRLEN<7:0> | | | | | | | 0000 | |
| 5024 | CETRLLEN | 31:16 | — | — | — | — | — | — | — | — | — | — | — | — | — | — | — | 0000 | |
| | | 15:0 | — | — | — | — | — | — | — | — | TRLRLEN<7:0> | | | | | | | 0000 | |

Legend: x = unknown value on Reset; — = unimplemented, read as '0'. Reset values are shown in hexadecimal.

PIC32MZ Embedded Connectivity with Floating Point Unit (EF) Family

REGISTER 26-1: CEVER: CRYPTO ENGINE REVISION, VERSION, AND ID REGISTER

| Bit Range | Bit 31/23/15/7 | Bit 30/22/14/6 | Bit 29/21/13/5 | Bit 28/20/12/4 | Bit 27/19/11/3 | Bit 26/18/10/2 | Bit 25/17/9/1 | Bit 24/16/8/0 |
|-----------|----------------|----------------|----------------|----------------|----------------|----------------|---------------|---------------|
| 31:24 | R-0 | R-0 | R-0 | R-0 | R-0 | R-0 | R-0 | R-0 |
| | REVISION<7:0> | | | | | | | |
| 23:16 | R-0 | R-0 | R-0 | R-0 | R-0 | R-0 | R-0 | R-0 |
| | VERSION<7:0> | | | | | | | |
| 15:8 | R-0 | R-0 | R-0 | R-0 | R-0 | R-0 | R-0 | R-0 |
| | ID<15:8> | | | | | | | |
| 7:0 | R-0 | R-0 | R-0 | R-0 | R-0 | R-0 | R-0 | R-0 |
| | ID<7:0> | | | | | | | |

Legend:

R = Readable bit
-n = Value at POR

W = Writable bit
'1' = Bit is set

U = Unimplemented bit, read as '0'
'0' = Bit is cleared
x = Bit is unknown

bit 31-24 **REVISION<7:0>**: Crypto Engine Revision bits

bit 23-16 **VERSION<7:0>**: Crypto Engine Version bits

bit 15-0 **ID<15:0>**: Crypto Engine Identification bits

PIC32MZ Embedded Connectivity with Floating Point Unit (EF) Family

REGISTER 26-2: CECON: CRYPTO ENGINE CONTROL REGISTER

| Bit Range | Bit 31/23/15/7 | Bit 30/22/14/6 | Bit 29/21/13/5 | Bit 28/20/12/4 | Bit 27/19/11/3 | Bit 26/18/10/2 | Bit 25/17/9/1 | Bit 24/16/8/0 |
|-----------|----------------|----------------|----------------|----------------|----------------|----------------|---------------|---------------|
| 31:24 | U-0 | U-0 | U-0 | U-0 | U-0 | U-0 | U-0 | U-0 |
| | — | — | — | — | — | — | — | — |
| 23:16 | U-0 | U-0 | U-0 | U-0 | U-0 | U-0 | U-0 | U-0 |
| | — | — | — | — | — | — | — | — |
| 15:8 | U-0 | U-0 | U-0 | U-0 | U-0 | U-0 | U-0 | U-0 |
| | — | — | — | — | — | — | — | — |
| 7:0 | R/W-0 | R/W-0, HC | R/W-0 | U-0 | U-0 | R/W-0 | R/W-0 | R/W-0 |
| | SWAPOEN | SWRST | SWAPEN | — | — | BDPCHST | BDPPLEN | DMAEN |

| | | |
|-------------------|------------------|--|
| Legend: | | HC = Hardware Cleared |
| R = Readable bit | W = Writable bit | U = Unimplemented bit, read as '0' |
| -n = Value at POR | '1' = Bit is set | '0' = Bit is cleared x = Bit is unknown |

- bit 31-8 **Unimplemented:** Read as '0'
- bit 7 **SWAPOEN:** Swap Output Data Enable bit
 - 1 = Output data is byte swapped when written by dedicated DMA
 - 0 = Output data is not byte swapped when written by dedicated DMA
- bit 6 **SWRST:** Software Reset bit
 - 1 = Initiate a software reset of the Crypto Engine
 - 0 = Normal operation
- bit 5 **SWAPEN:** Input Data Swap Enable bit
 - 1 = Input data is byte swapped when read by dedicated DMA
 - 0 = Input data is not byte swapped when read by dedicated DMA
- bit 4-3 **Unimplemented:** Read as '0'
- bit 2 **BDPCHST:** Buffer Descriptor Processor (BDP) Fetch Enable bit

This bit should be enabled only after all DMA descriptor programming is completed.

 - 1 = BDP descriptor fetch is enabled
 - 0 = BDP descriptor fetch is disabled
- bit 1 **BDPPLEN:** Buffer Descriptor Processor Poll Enable bit

This bit should be enabled only after all DMA descriptor programming is completed.

 - 1 = Poll for descriptor until valid bit is set
 - 0 = Do not poll
- bit 0 **DMAEN:** DMA Enable bit
 - 1 = Crypto Engine DMA is enabled
 - 0 = Crypto Engine DMA is disabled

PIC32MZ Embedded Connectivity with Floating Point Unit (EF) Family

REGISTER 26-3: CEBDADDR: CRYPTO ENGINE BUFFER DESCRIPTOR REGISTER

| Bit Range | Bit 31/23/15/7 | Bit 30/22/14/6 | Bit 29/21/13/5 | Bit 28/20/12/4 | Bit 27/19/11/3 | Bit 26/18/10/2 | Bit 25/17/9/1 | Bit 24/16/8/0 |
|----------------|----------------|----------------|----------------|----------------|----------------|----------------|---------------|---------------|
| 31:24 | R-0 | R-0 | R-0 | R-0 | R-0 | R-0 | R-0 | R-0 |
| BDPADDR<31:24> | | | | | | | | |
| 23:16 | R-0 | R-0 | R-0 | R-0 | R-0 | R-0 | R-0 | R-0 |
| BDPADDR<23:16> | | | | | | | | |
| 15:8 | R-0 | R-0 | R-0 | R-0 | R-0 | R-0 | R-0 | R-0 |
| BDPADDR<15:8> | | | | | | | | |
| 7:0 | R-0 | R-0 | R-0 | R-0 | R-0 | R-0 | R-0 | R-0 |
| BDPADDR<7:0> | | | | | | | | |

Legend:

R = Readable bit
-n = Value at POR

W = Writable bit
'1' = Bit is set

U = Unimplemented bit, read as '0'
'0' = Bit is cleared
x = Bit is unknown

bit 31-0 **BDPADDR<31:0>**: Current Buffer Descriptor Process Address Status bits

These bits contain the current descriptor address that is being processed by the Buffer Descriptor Processor (BDP).

REGISTER 26-4: CEBDPADDR: CRYPTO ENGINE BUFFER DESCRIPTOR PROCESSOR REGISTER

| Bit Range | Bit 31/23/15/7 | Bit 30/22/14/6 | Bit 29/21/13/5 | Bit 28/20/12/4 | Bit 27/19/11/3 | Bit 26/18/10/2 | Bit 25/17/9/1 | Bit 24/16/8/0 |
|-----------------|----------------|----------------|----------------|----------------|----------------|----------------|---------------|---------------|
| 31:24 | R/W-0 | R/W-0 | R/W-0 | R/W-0 | R/W-0 | R/W-0 | R/W-0 | R/W-0 |
| BASEADDR<31:24> | | | | | | | | |
| 23:16 | R/W-0 | R/W-0 | R/W-0 | R/W-0 | R/W-0 | R/W-0 | R/W-0 | R/W-0 |
| BASEADDR<23:16> | | | | | | | | |
| 15:8 | R/W-0 | R/W-0 | R/W-0 | R/W-0 | R/W-0 | R/W-0 | R/W-0 | R/W-0 |
| BASEADDR<15:8> | | | | | | | | |
| 7:0 | R/W-0 | R/W-0 | R/W-0 | R/W-0 | R/W-0 | R/W-0 | R/W-0 | R/W-0 |
| BASEADDR<7:0> | | | | | | | | |

Legend:

R = Readable bit
-n = Value at POR

W = Writable bit
'1' = Bit is set

U = Unimplemented bit, read as '0'
'0' = Bit is cleared
x = Bit is unknown

bit 31-0 **BASEADDR<31:0>**: Buffer Descriptor Base Address bits

These bits contain the physical address of the first Buffer Descriptor in the Buffer Descriptor chain. When enabled, the Crypto DMA begins fetching Buffer Descriptors from this address.

PIC32MZ Embedded Connectivity with Floating Point Unit (EF) Family

REGISTER 26-5: CESTAT: CRYPTO ENGINE STATUS REGISTER

| Bit Range | Bit 31/23/15/7 | Bit 30/22/14/6 | Bit 29/21/13/5 | Bit 28/20/12/4 | Bit 27/19/11/3 | Bit 26/18/10/2 | Bit 25/17/9/1 | Bit 24/16/8/0 |
|-----------|----------------|----------------|----------------|----------------|----------------|----------------|---------------|---------------|
| 31:24 | R-0 | R-0 | R-0 | R-0 | R-0 | R-0 | R-0 | R-0 |
| | ERRMODE<2:0> | | | ERROP<2:0> | | | ERRPHASE<1:0> | |
| 23:16 | U-0 | U-0 | R-0 | R-0 | R-0 | R-0 | R-0 | R-0 |
| | — | — | BDSTATE<3:0> | | | | START | ACTIVE |
| 15:8 | R-0 | R-0 | R-0 | R-0 | R-0 | R-0 | R-0 | R-0 |
| | BDCTRL<15:8> | | | | | | | |
| 7:0 | R-0 | R-0 | R-0 | R-0 | R-0 | R-0 | R-0 | R-0 |
| | BDCTRL<7:0> | | | | | | | |

Legend:

| | | |
|-------------------|------------------|--|
| R = Readable bit | W = Writable bit | U = Unimplemented bit, read as '0' |
| -n = Value at POR | '1' = Bit is set | '0' = Bit is cleared x = Bit is unknown |

bit 31-29 **ERRMODE<2:0>**: Internal Error Mode Status bits

- 111 = Reserved
- 110 = Reserved
- 101 = Reserved
- 100 = Reserved
- 011 = CEK operation
- 010 = KEK operation
- 001 = Preboot authentication
- 000 = Normal operation

bit 28-26 **ERROP<2:0>**: Internal Error Operation Status bits

- 111 = Reserved
- 110 = Reserved
- 101 = Reserved
- 100 = Authentication
- 011 = Reserved
- 010 = Decryption
- 001 = Encryption
- 000 = Reserved

bit 25-24 **ERRPHASE<1:0>**: Internal Error Phase of DMA Status bits

- 11 = Destination data
- 10 = Source data
- 01 = Security Association (SA) access
- 00 = Buffer Descriptor (BD) access

bit 23-22 **Unimplemented**: Read as '0'

bit 21-18 **BDSTATE<3:0>**: Buffer Descriptor Processor State Status bits

- The current state of the BDP:
- 1111 = Reserved
 - .
 - .
 - 0111 = Reserved
 - 0110 = SA fetch
 - 0101 = Fetch BDP is disabled
 - 0100 = Descriptor is done
 - 0011 = Data phase
 - 0010 = BDP is loading
 - 0001 = Descriptor fetch request is pending
 - 0000 = BDP is idle

bit 17 **START**: DMA Start Status bit

- 1 = DMA start has occurred
- 0 = DMA start has not occurred

PIC32MZ Embedded Connectivity with Floating Point Unit (EF) Family

REGISTER 26-5: CESTAT: CRYPTO ENGINE STATUS REGISTER (CONTINUED)

bit 16 **ACTIVE:** Buffer Descriptor Processor Status bit

1 = BDP is active

0 = BDP is idle

bit 15-0 **BDCTRL<15:0>:** Descriptor Control Word Status bits

These bits contain the Control Word for the current Buffer Descriptor.

PIC32MZ Embedded Connectivity with Floating Point Unit (EF) Family

REGISTER 26-6: CEINTSRC: CRYPTO ENGINE INTERRUPT SOURCE REGISTER

| Bit Range | Bit 31/23/15/7 | Bit 30/22/14/6 | Bit 29/21/13/5 | Bit 28/20/12/4 | Bit 27/19/11/3 | Bit 26/18/10/2 | Bit 25/17/9/1 | Bit 24/16/8/0 |
|-----------|----------------|----------------|----------------|----------------|----------------|----------------|---------------|---------------|
| 31:24 | U-0 | U-0 | U-0 | U-0 | U-0 | U-0 | U-0 | U-0 |
| | — | — | — | — | — | — | — | — |
| 23:16 | U-0 | U-0 | U-0 | U-0 | U-0 | U-0 | U-0 | U-0 |
| | — | — | — | — | — | — | — | — |
| 15:8 | U-0 | U-0 | U-0 | U-0 | U-0 | U-0 | U-0 | U-0 |
| | — | — | — | — | — | — | — | — |
| 7:0 | U-0 | U-0 | U-0 | U-0 | R-0 | R-0 | R-0 | R-0 |
| | — | — | — | — | AREIF | PKTIF | CBDIF | PENDIF |

Legend:

R = Readable bit

W = Writable bit

U = Unimplemented bit, read as '0'

-n = Value at POR

'1' = Bit is set

'0' = Bit is cleared

x = Bit is unknown

bit 31-4 **Unimplemented:** Read as '0'

bit 3 **AREIF:** Access Response Error Interrupt bit

1 = Error occurred trying to access memory outside the Crypto Engine

0 = No error has occurred

bit 2 **PKTIF:** DMA Packet Completion Interrupt Status bit

1 = DMA packet was completed

0 = DMA packet was not completed

bit 1 **CBDIF:** BD Transmit Status bit

1 = Last BD transmit was processed

0 = Last BD transmit has not been processed

bit 0 **PENDIF:** Crypto Engine Interrupt Pending Status bit

1 = Crypto Engine interrupt is pending (this value is the result of an OR of all interrupts in the Crypto Engine)

0 = Crypto Engine interrupt is not pending

PIC32MZ Embedded Connectivity with Floating Point Unit (EF) Family

REGISTER 26-7: CEINTEN: CRYPTO ENGINE INTERRUPT ENABLE REGISTER

| Bit Range | Bit 31/23/15/7 | Bit 30/22/14/6 | Bit 29/21/13/5 | Bit 28/20/12/4 | Bit 27/19/11/3 | Bit 26/18/10/2 | Bit 25/17/9/1 | Bit 24/16/8/0 |
|-----------|----------------|----------------|----------------|----------------|----------------|----------------|---------------|-----------------------|
| 31:24 | U-0 | U-0 | U-0 | U-0 | U-0 | U-0 | U-0 | U-0 |
| | — | — | — | — | — | — | — | — |
| 23:16 | U-0 | U-0 | U-0 | U-0 | U-0 | U-0 | U-0 | U-0 |
| | — | — | — | — | — | — | — | — |
| 15:8 | U-0 | U-0 | U-0 | U-0 | U-0 | U-0 | U-0 | U-0 |
| | — | — | — | — | — | — | — | — |
| 7:0 | U-0 | U-0 | U-0 | U-0 | R/W-0 | R/W-0 | R/W-0 | R/W-0 |
| | — | — | — | — | AREIE | PKTIE | BDPIE | PENDIE ⁽¹⁾ |

Legend:

R = Readable bit
-n = Value at POR

W = Writable bit
'1' = Bit is set

U = Unimplemented bit, read as '0'
'0' = Bit is cleared
x = Bit is unknown

bit 31-4 **Unimplemented:** Read as '0'

bit 3 **AREIE:** Access Response Error Interrupt Enable bit
1 = Access response error interrupts are enabled
0 = Access response error interrupts are not enabled

bit 2 **PKTIE:** DMA Packet Completion Interrupt Enable bit
1 = DMA packet completion interrupts are enabled
0 = DMA packet completion interrupts are not enabled

bit 1 **BDPIE:** DMA Buffer Descriptor Processor Interrupt Enable bit
1 = BDP interrupts are enabled
0 = BDP interrupts are not enabled

bit 0 **PENDIE:** Master Interrupt Enable bit⁽¹⁾
1 = Crypto Engine interrupts are enabled
0 = Crypto Engine interrupts are not enabled

Note 1: The PENDIE bit is a Global enable bit and must be enabled together with the other interrupts desired.

PIC32MZ Embedded Connectivity with Floating Point Unit (EF) Family

REGISTER 26-8: CEPOLLCON: CRYPTO ENGINE POLL CONTROL REGISTER

| Bit Range | Bit 31/23/15/7 | Bit 30/22/14/6 | Bit 29/21/13/5 | Bit 28/20/12/4 | Bit 27/19/11/3 | Bit 26/18/10/2 | Bit 25/17/9/1 | Bit 24/16/8/0 |
|-----------|----------------|----------------|----------------|----------------|----------------|----------------|---------------|---------------|
| 31:24 | U-0 | U-0 | U-0 | U-0 | U-0 | U-0 | U-0 | U-0 |
| | — | — | — | — | — | — | — | — |
| 23:16 | U-0 | U-0 | U-0 | U-0 | U-0 | U-0 | U-0 | U-0 |
| | — | — | — | — | — | — | — | — |
| 15:8 | R/W-0 | R/W-0 | R/W-0 | R/W-0 | R/W-0 | R/W-0 | R/W-0 | R/W-0 |
| | BDPPLCON<15:8> | | | | | | | |
| 7:0 | R/W-0 | R/W-0 | R/W-0 | R/W-0 | R/W-0 | R/W-0 | R/W-0 | R/W-0 |
| | BDPPLCON<7:0> | | | | | | | |

Legend:

R = Readable bit

W = Writable bit

U = Unimplemented bit, read as '0'

-n = Value at POR

'1' = Bit is set

'0' = Bit is cleared

x = Bit is unknown

bit 31-16 **Unimplemented:** Read as '0'

bit 15 **BDPPLCON<15:0>:** Buffer Descriptor Processor Poll Control bits

These bits determine the number of SYSClk cycles that the Crypto DMA would wait before refetching the descriptor control word if the Buffer Descriptor fetched was disabled.

PIC32MZ Embedded Connectivity with Floating Point Unit (EF) Family

REGISTER 26-9: CEHDLEN: CRYPTO ENGINE HEADER LENGTH REGISTER

| Bit Range | Bit 31/23/15/7 | Bit 30/22/14/6 | Bit 29/21/13/5 | Bit 28/20/12/4 | Bit 27/19/11/3 | Bit 26/18/10/2 | Bit 25/17/9/1 | Bit 24/16/8/0 |
|-----------|----------------|----------------|----------------|----------------|----------------|----------------|---------------|---------------|
| 31:24 | U-0 | U-0 | U-0 | U-0 | U-0 | U-0 | U-0 | U-0 |
| | — | — | — | — | — | — | — | — |
| 23:16 | U-0 | U-0 | U-0 | U-0 | U-0 | U-0 | U-0 | U-0 |
| | — | — | — | — | — | — | — | — |
| 15:8 | U-0 | U-0 | U-0 | U-0 | U-0 | U-0 | U-0 | U-0 |
| | — | — | — | — | — | — | — | — |
| 7:0 | R/W-0 | R/W-0 | R/W-0 | R/W-0 | R/W-0 | R/W-0 | R/W-0 | R/W-0 |
| | HDRLEN<7:0> | | | | | | | |

Legend:

R = Readable bit
-n = Value at POR

W = Writable bit
'1' = Bit is set

U = Unimplemented bit, read as '0'
'0' = Bit is cleared
x = Bit is unknown

bit 31-8 **Unimplemented:** Read as '0'

bit 7-0 **HDRLEN<7:0>**: DMA Header Length bits

For every packet, skip this length of locations and start filling the data.

REGISTER 26-10: CETRLLEN: CRYPTO ENGINE TRAILER LENGTH REGISTER

| Bit Range | Bit 31/23/15/7 | Bit 30/22/14/6 | Bit 29/21/13/5 | Bit 28/20/12/4 | Bit 27/19/11/3 | Bit 26/18/10/2 | Bit 25/17/9/1 | Bit 24/16/8/0 |
|-----------|----------------|----------------|----------------|----------------|----------------|----------------|---------------|---------------|
| 31:24 | U-0 | U-0 | U-0 | U-0 | U-0 | U-0 | U-0 | U-0 |
| | — | — | — | — | — | — | — | — |
| 23:16 | U-0 | U-0 | U-0 | U-0 | U-0 | U-0 | U-0 | U-0 |
| | — | — | — | — | — | — | — | — |
| 15:8 | U-0 | U-0 | U-0 | U-0 | U-0 | U-0 | U-0 | U-0 |
| | — | — | — | — | — | — | — | — |
| 7:0 | R/W-0 | R/W-0 | R/W-0 | R/W-0 | R/W-0 | R/W-0 | R/W-0 | R/W-0 |
| | TRLRLEN<7:0> | | | | | | | |

Legend:

R = Readable bit
-n = Value at POR

W = Writable bit
'1' = Bit is set

U = Unimplemented bit, read as '0'
'0' = Bit is cleared
x = Bit is unknown

bit 31-8 **Unimplemented:** Read as '0'

bit 7-0 **TRLRLEN<7:0>**: DMA Trailer Length bits

For every packet, skip this length of locations at the end of the current packet and start putting the next packet.

PIC32MZ Embedded Connectivity with Floating Point Unit (EF) Family

26.2 Crypto Engine Buffer Descriptors

Host software creates a linked list of buffer descriptors and the hardware updates them. Table 26-3 provides a list of the Crypto Engine buffer descriptors, followed by format descriptions of each buffer descriptor (see Figure 26-2 through Figure 26-9).

TABLE 26-3: CRYPTO ENGINE BUFFER DESCRIPTORS

| Name (see Note 1) | Bit 31/23/15/7 | Bit 30/22/14/6 | Bit 29/21/13/5 | Bit 28/20/12/4 | Bit 27/19/11/3 | Bit 26/18/10/2 | Bit 25/17/9/1 | Bit 24/16/8/0 | |
|-------------------|-------------------|--------------------|-------------------|-------------------|-------------------|-------------------|------------------|------------------|------------|
| BD_CTRL | 31:24 | DESC_EN | — | CRY_MODE<2:0> | | | — | — | — |
| | 23:16 | — | SA_FETCH_EN | — | — | LAST_BD | LIFM | PKT_INT_EN | CBD_INT_EN |
| | 15:8 | BD_BUFLEN<15:8> | | | | | | | |
| | 7:0 | BD_BUFLEN<7:0> | | | | | | | |
| BD_SA_ADDR | 31:24 | BD_SAADDR<31:24> | | | | | | | |
| | 23:16 | BD_SAADDR<23:16> | | | | | | | |
| | 15:8 | BD_SAADDR<15:8> | | | | | | | |
| | 7:0 | BD_SAADDR<7:0> | | | | | | | |
| BD_SCRADDR | 31:24 | BD_SRCADDR<31:24> | | | | | | | |
| | 23:16 | BD_SRCADDR<23:16> | | | | | | | |
| | 15:8 | BD_SRCADDR<15:8> | | | | | | | |
| | 7:0 | BD_SRCADDR<7:0> | | | | | | | |
| BD_DSTADDR | 31:24 | BD_DSTADDR<31:24> | | | | | | | |
| | 23:16 | BD_DSTADDR<23:16> | | | | | | | |
| | 15:8 | BD_DSTADDR<15:8> | | | | | | | |
| | 7:0 | BD_DSTADDR<7:0> | | | | | | | |
| BD_NXTPTR | 31:24 | BD_NXTADDR<31:24> | | | | | | | |
| | 23:16 | BD_NXTADDR<23:16> | | | | | | | |
| | 15:8 | BD_NXTADDR<15:8> | | | | | | | |
| | 7:0 | BD_NXTADDR<7:0> | | | | | | | |
| BD_UPDPTR | 31:24 | BD_UPDADDR<31:24> | | | | | | | |
| | 23:16 | BD_UPDADDR<23:16> | | | | | | | |
| | 15:8 | BD_UPDADDR<15:8> | | | | | | | |
| | 7:0 | BD_UPDADDR<7:0> | | | | | | | |
| BD_MSG_LEN | 31:24 | MSG_LENGTH<31:24> | | | | | | | |
| | 23:16 | MSG_LENGTH<23:16> | | | | | | | |
| | 15:8 | MSG_LENGTH<15:8> | | | | | | | |
| | 7:0 | MSG_LENGTH<7:0> | | | | | | | |
| BD_ENC_OFF | 31:24 | ENCR_OFFSET<31:24> | | | | | | | |
| | 23:16 | ENCR_OFFSET<23:16> | | | | | | | |
| | 15:8 | ENCR_OFFSET<15:8> | | | | | | | |
| | 7:0 | ENCR_OFFSET<7:0> | | | | | | | |

Note 1: The buffer descriptor must be allocated in memory on a 64-bit boundary.

PIC32MZ Embedded Connectivity with Floating Point Unit (EF) Family

FIGURE 26-2: FORMAT OF BD_CTRL

| Bit Range | Bit 31/23/15/7 | Bit 30/22/14/6 | Bit 29/21/13/5 | Bit 28/20/12/4 | Bit 27/19/11/3 | Bit 26/18/10/2 | Bit 25/17/9/1 | Bit 24/16/8/0 |
|-----------|-----------------|----------------|----------------|----------------|----------------|----------------|---------------|---------------|
| 31-24 | DESC_EN | — | CRY_MODE<2:0> | | | — | — | — |
| 23-16 | — | SA_FETCH_EN | — | — | LAST_BD | LIFM | PKT_INT_EN | CBD_INT_EN |
| 15-8 | BD_BUFLEN<15:8> | | | | | | | |
| 7-0 | BD_BUFLEN<7:0> | | | | | | | |

bit 31 **DESC_EN:** Descriptor Enable
1 = The descriptor is owned by hardware. After processing the BD, hardware resets this bit to '0'.
0 = The descriptor is owned by software

bit 30 **Unimplemented:** Must be written as '0'

bit 29-27 **CRY_MODE<2:0>:** Crypto Mode
111 = Reserved
110 = Reserved
101 = Reserved
100 = Reserved
011 = CEK operation
010 = KEK operation
001 = Preboot authentication
000 = Normal operation

bit 22 **SA_FETCH_EN:** Fetch Security Association From External Memory
1 = Fetch SA from the SA pointer. This bit needs to be set to '1' for every new packet.
0 = Use current fetched SA or the internal SA

bit 21-20 **Unimplemented:** Must be written as '0'

bit 19 **LAST_BD:** Last Buffer Descriptors
1 = Last Buffer Descriptor in the chain
0 = More Buffer Descriptors in the chain
After the last BD, the CEBDADDR goes to the base address in CEBDPADDR.

bit 18 **LIFM:** Last In Frame
In case of Receive Packets (from H/W-> Host), this field is filled by the Hardware to indicate whether the packet goes across multiple buffer descriptors. In case of transmit packets (from Host -> H/W), this field indicates whether this BD is the last in the frame.

bit 17 **PKT_INT_EN:** Packet Interrupt Enable
Generate an interrupt after processing the current buffer descriptor, if it is the end of the packet.

bit 16 **CBD_INT_EN:** CBD Interrupt Enable
Generate an interrupt after processing the current buffer descriptor.

bit 15-0 **BD_BUFLEN<15:0>:** Buffer Descriptor Length
This field contains the length of the buffer and is updated with the actual length filled by the receiver.

FIGURE 26-3: FORMAT OF BD_SADDR

| Bit Range | Bit 31/23/15/7 | Bit 30/22/14/6 | Bit 29/21/13/5 | Bit 28/20/12/4 | Bit 27/19/11/3 | Bit 26/18/10/2 | Bit 25/17/9/1 | Bit 24/16/8/0 |
|-----------|------------------|----------------|----------------|----------------|----------------|----------------|---------------|---------------|
| 31-24 | BD_SAADDR<31:24> | | | | | | | |
| 23-16 | BD_SAADDR<23:16> | | | | | | | |
| 15-8 | BD_SAADDR<15:8> | | | | | | | |
| 7-0 | BD_SAADDR<7:0> | | | | | | | |

bit 31-0 **BD_SAADDR<31:0>:** Security Association IP Session Address
The sessions' SA pointer has the keys and IV values.

PIC32MZ Embedded Connectivity with Floating Point Unit (EF) Family

FIGURE 26-4: FORMAT OF BD_SRCADDR

| Bit Range | Bit 31/23/15/7 | Bit 30/22/14/6 | Bit 29/21/13/5 | Bit 28/20/12/4 | Bit 27/19/11/3 | Bit 26/18/10/2 | Bit 25/17/9/1 | Bit 24/16/8/0 |
|-----------|-------------------|----------------|----------------|----------------|----------------|----------------|---------------|---------------|
| 31-24 | BD_SCRADDR<31:24> | | | | | | | |
| 23-16 | BD_SCRADDR<23:16> | | | | | | | |
| 15-8 | BD_SCRADDR<15:8> | | | | | | | |
| 7-0 | BD_SCRADDR<7:0> | | | | | | | |

bit 31-0 **BD_SCRADDR:** Buffer Source Address

The source address of the buffer that needs to be passed through the PE-CRDMA for encryption or authentication. This address must be on a 32-bit boundary.

FIGURE 26-5: FORMAT OF BD_DSTADDR

| Bit Range | Bit 31/23/15/7 | Bit 30/22/14/6 | Bit 29/21/13/5 | Bit 28/20/12/4 | Bit 27/19/11/3 | Bit 26/18/10/2 | Bit 25/17/9/1 | Bit 24/16/8/0 |
|-----------|-------------------|----------------|----------------|----------------|----------------|----------------|---------------|---------------|
| 31-24 | BD_DSTADDR<31:24> | | | | | | | |
| 23-16 | BD_DSTADDR<23:16> | | | | | | | |
| 15-8 | BD_DSTADDR<15:8> | | | | | | | |
| 7-0 | BD_DSTADDR<7:0> | | | | | | | |

bit 31-0 **BD_DSTADDR:** Buffer Destination Address

The destination address of the buffer that needs to be passed through the PE-CRDMA for encryption or authentication. This address must be on a 32-bit boundary.

FIGURE 26-6: FORMAT OF BD_NXTADDR

| Bit Range | Bit 31/23/15/7 | Bit 30/22/14/6 | Bit 29/21/13/5 | Bit 28/20/12/4 | Bit 27/19/11/3 | Bit 26/18/10/2 | Bit 25/17/9/1 | Bit 24/16/8/0 |
|-----------|-------------------|----------------|----------------|----------------|----------------|----------------|---------------|---------------|
| 31-24 | BD_NXTADDR<31:24> | | | | | | | |
| 23-16 | BD_NXTADDR<23:16> | | | | | | | |
| 15-8 | BD_NXTADDR<15:8> | | | | | | | |
| 7-0 | BD_NXTADDR<7:0> | | | | | | | |

bit 31-0 **BD_NXTADDR:** Next BD Pointer Address Has Next Buffer Descriptor

The next buffer can be a next segment of the previous buffer or a new packet.

PIC32MZ Embedded Connectivity with Floating Point Unit (EF) Family

FIGURE 26-7: FORMAT OF BD_UPDPTR

| Bit Range | Bit 31/23/15/7 | Bit 30/22/14/6 | Bit 29/21/13/5 | Bit 28/20/12/4 | Bit 27/19/11/3 | Bit 26/18/10/2 | Bit 25/17/9/1 | Bit 24/16/8/0 |
|-----------|-------------------|----------------|----------------|----------------|----------------|----------------|---------------|---------------|
| 31-24 | BD_UPDADDR<31:24> | | | | | | | |
| 23-16 | BD_UPDADDR<23:16> | | | | | | | |
| 15-8 | BD_UPDADDR<15:8> | | | | | | | |
| 7-0 | BD_UPDADDR<7:0> | | | | | | | |

bit 31-0 **BD_UPDADDR:** UPD Address Location
 The update address has the location where the CRDMA results are posted. The updated results are the ICV values, key output values as needed.

FIGURE 26-8: FORMAT OF BD_MSG_LEN

| Bit Range | Bit 31/23/15/7 | Bit 30/22/14/6 | Bit 29/21/13/5 | Bit 28/20/12/4 | Bit 27/19/11/3 | Bit 26/18/10/2 | Bit 25/17/9/1 | Bit 24/16/8/0 |
|-----------|-------------------|----------------|----------------|----------------|----------------|----------------|---------------|---------------|
| 31-24 | MSG_LENGTH<31:24> | | | | | | | |
| 23-16 | MSG_LENGTH<23:16> | | | | | | | |
| 15-8 | MSG_LENGTH<15:8> | | | | | | | |
| 7-0 | MSG_LENGTH<7:0> | | | | | | | |

bit 31-0 **MSG_LENGTH:** Total Message Length
 Total message length for the hash and HMAC algorithms in bytes. Total number of crypto bytes in case of GCM algorithm (LEN-C).

FIGURE 26-9: FORMAT OF BD_ENC_OFF

| Bit Range | Bit 31/23/15/7 | Bit 30/22/14/6 | Bit 29/21/13/5 | Bit 28/20/12/4 | Bit 27/19/11/3 | Bit 26/18/10/2 | Bit 25/17/9/1 | Bit 24/16/8/0 |
|-----------|--------------------|----------------|----------------|----------------|----------------|----------------|---------------|---------------|
| 31-24 | ENCR_OFFSET<31:24> | | | | | | | |
| 23-16 | ENCR_OFFSET<23:16> | | | | | | | |
| 15-8 | ENCR_OFFSET<15:8> | | | | | | | |
| 7-0 | ENCR_OFFSET<7:0> | | | | | | | |

bit 31-0 **ENCR_OFFSET:** Encryption Offset
 Encryption offset for the multi-task test cases (both encryption and authentication). The number of AAD bytes in the case of GCM algorithm (LEN-A).

PIC32MZ Embedded Connectivity with Floating Point Unit (EF) Family

26.3 Security Association Structure

Table 26-4 shows the Security Association Structure.

The Crypto Engine uses the Security Association to determine the settings for processing a Buffer Descriptor Processor. The Security Association contains:

- Which algorithm to use
- Whether to use engines in parallel (for both authentication and encryption/decryption)
- The size of the key
- Authentication key
- Encryption/decryption key
- Authentication Initialization Vector (IV)
- Encryption IV

TABLE 26-4: CRYPTO ENGINE SECURITY ASSOCIATION STRUCTURE

| Name | Bit 31/23/15/7 | Bit 30/22/14/6 | Bit 29/21/13/5 | Bit 28/20/12/4 | Bit 27/19/11/3 | Bit 26/18/10/2 | Bit 25/17/9/1 | Bit 24/16/8/0 |
|-------------|-------------------|-------------------|-------------------|-------------------|-------------------|-------------------|------------------|------------------|
| SA_CTRL | 31:24 | — | — | VERIFY | — | NO_RX | OR_EN | ICVONLY |
| | 23:16 | LNC | LOADIV | FB | FLAGS | — | — | — |
| | 15:8 | ALGO<5:0> | | | | | ENCTYPE | KEYSIZE<1> |
| | 7:0 | KEYSIZE<0> | MULTITASK<2:0> | | | CRYPTOALGO<3:0> | | |
| SA_AUTHKEY1 | 31:24 | AUTHKEY<31:24> | | | | | | |
| | 23:16 | AUTHKEY<23:16> | | | | | | |
| | 15:8 | AUTHKEY<15:8> | | | | | | |
| | 7:0 | AUTHKEY<7:0> | | | | | | |
| SA_AUTHKEY2 | 31:24 | AUTHKEY<31:24> | | | | | | |
| | 23:16 | AUTHKEY<23:16> | | | | | | |
| | 15:8 | AUTHKEY<15:8> | | | | | | |
| | 7:0 | AUTHKEY<7:0> | | | | | | |
| SA_AUTHKEY3 | 31:24 | AUTHKEY<31:24> | | | | | | |
| | 23:16 | AUTHKEY<23:16> | | | | | | |
| | 15:8 | AUTHKEY<15:8> | | | | | | |
| | 7:0 | AUTHKEY<7:0> | | | | | | |
| SA_AUTHKEY4 | 31:24 | AUTHKEY<31:24> | | | | | | |
| | 23:16 | AUTHKEY<23:16> | | | | | | |
| | 15:8 | AUTHKEY<15:8> | | | | | | |
| | 7:0 | AUTHKEY<7:0> | | | | | | |
| SA_AUTHKEY5 | 31:24 | AUTHKEY<31:24> | | | | | | |
| | 23:16 | AUTHKEY<23:16> | | | | | | |
| | 15:8 | AUTHKEY<15:8> | | | | | | |
| | 7:0 | AUTHKEY<7:0> | | | | | | |
| SA_AUTHKEY6 | 31:24 | AUTHKEY<31:24> | | | | | | |
| | 23:16 | AUTHKEY<23:16> | | | | | | |
| | 15:8 | AUTHKEY<15:8> | | | | | | |
| | 7:0 | AUTHKEY<7:0> | | | | | | |
| SA_AUTHKEY7 | 31:24 | AUTHKEY<31:24> | | | | | | |
| | 23:16 | AUTHKEY<23:16> | | | | | | |
| | 15:8 | AUTHKEY<15:8> | | | | | | |
| | 7:0 | AUTHKEY<7:0> | | | | | | |
| SA_AUTHKEY8 | 31:24 | AUTHKEY<31:24> | | | | | | |
| | 23:16 | AUTHKEY<23:16> | | | | | | |
| | 15:8 | AUTHKEY<15:8> | | | | | | |
| | 7:0 | AUTHKEY<7:0> | | | | | | |
| SA_ENCKEY1 | 31:24 | ENCKEY<31:24> | | | | | | |
| | 23:16 | ENCKEY<23:16> | | | | | | |
| | 15:8 | ENCKEY<15:8> | | | | | | |
| | 7:0 | ENCKEY<7:0> | | | | | | |
| SA_ENCKEY2 | 31:24 | ENCKEY<31:24> | | | | | | |

PIC32MZ Embedded Connectivity with Floating Point Unit (EF) Family

TABLE 26-4: CRYPTO ENGINE SECURITY ASSOCIATION STRUCTURE (CONTINUED)

| Name | Bit 31/23/15/7 | Bit 30/22/14/6 | Bit 29/21/13/5 | Bit 28/20/12/4 | Bit 27/19/11/3 | Bit 26/18/10/2 | Bit 25/17/9/1 | Bit 24/16/8/0 |
|------------|-------------------|-------------------|-------------------|-------------------|-------------------|-------------------|------------------|------------------|
| | 23:16 | ENCKEY<23:16> | | | | | | |
| | 15:8 | ENCKEY<15:8> | | | | | | |
| | 7:0 | ENCKEY<7:0> | | | | | | |
| SA_ENCKEY3 | 31:24 | ENCKEY<31:24> | | | | | | |
| | 23:16 | ENCKEY<23:16> | | | | | | |
| | 15:8 | ENCKEY<15:8> | | | | | | |
| | 7:0 | ENCKEY<7:0> | | | | | | |
| SA_ENCKEY4 | 31:24 | ENCKEY<31:24> | | | | | | |
| | 23:16 | ENCKEY<23:16> | | | | | | |
| | 15:8 | ENCKEY<15:8> | | | | | | |
| | 7:0 | ENCKEY<7:0> | | | | | | |
| SA_ENCKEY5 | 31:24 | ENCKEY<31:24> | | | | | | |
| | 23:16 | ENCKEY<23:16> | | | | | | |
| | 15:8 | ENCKEY<15:8> | | | | | | |
| | 7:0 | ENCKEY<7:0> | | | | | | |
| SA_ENCKEY6 | 31:24 | ENCKEY<31:24> | | | | | | |
| | 23:16 | ENCKEY<23:16> | | | | | | |
| | 15:8 | ENCKEY<15:8> | | | | | | |
| | 7:0 | ENCKEY<7:0> | | | | | | |
| SA_ENCKEY7 | 31:24 | ENCKEY<31:24> | | | | | | |
| | 23:16 | ENCKEY<23:16> | | | | | | |
| | 15:8 | ENCKEY<15:8> | | | | | | |
| | 7:0 | ENCKEY<7:0> | | | | | | |
| SA_ENCKEY8 | 31:24 | ENCKEY<31:24> | | | | | | |
| | 23:16 | ENCKEY<23:16> | | | | | | |
| | 15:8 | ENCKEY<15:8> | | | | | | |
| | 7:0 | ENCKEY<7:0> | | | | | | |
| SA_AUTHIV1 | 31:24 | AUTHIV<31:24> | | | | | | |
| | 23:16 | AUTHIV<23:16> | | | | | | |
| | 15:8 | AUTHIV<15:8> | | | | | | |
| | 7:0 | AUTHIV<7:0> | | | | | | |
| SA_AUTHIV2 | 31:24 | AUTHIV<31:24> | | | | | | |
| | 23:16 | AUTHIV<23:16> | | | | | | |
| | 15:8 | AUTHIV<15:8> | | | | | | |
| | 7:0 | AUTHIV<7:0> | | | | | | |
| SA_AUTHIV3 | 31:24 | AUTHIV<31:24> | | | | | | |
| | 23:16 | AUTHIV<23:16> | | | | | | |
| | 15:8 | AUTHIV<15:8> | | | | | | |
| | 7:0 | AUTHIV<7:0> | | | | | | |
| SA_AUTHIV4 | 31:24 | AUTHIV<31:24> | | | | | | |
| | 23:16 | AUTHIV<23:16> | | | | | | |
| | 15:8 | AUTHIV<15:8> | | | | | | |
| | 7:0 | AUTHIV<7:0> | | | | | | |
| SA_AUTHIV5 | 31:24 | AUTHIV<31:24> | | | | | | |
| | 23:16 | AUTHIV<23:16> | | | | | | |
| | 15:8 | AUTHIV<15:8> | | | | | | |
| | 7:0 | AUTHIV<7:0> | | | | | | |
| SA_AUTHIV6 | 31:24 | AUTHIV<31:24> | | | | | | |
| | 23:16 | AUTHIV<23:16> | | | | | | |
| | 15:8 | AUTHIV<15:8> | | | | | | |
| | 7:0 | AUTHIV<7:0> | | | | | | |
| SA_AUTHIV7 | 31:24 | AUTHIV<31:24> | | | | | | |
| | 23:16 | AUTHIV<23:16> | | | | | | |
| | 15:8 | AUTHIV<15:8> | | | | | | |
| | 7:0 | AUTHIV<7:0> | | | | | | |
| SA_AUTHIV8 | 31:24 | AUTHIV<31:24> | | | | | | |
| | 23:16 | AUTHIV<23:16> | | | | | | |
| | 15:8 | AUTHIV<15:8> | | | | | | |
| | 7:0 | AUTHIV<7:0> | | | | | | |

PIC32MZ Embedded Connectivity with Floating Point Unit (EF) Family

TABLE 26-4: CRYPTO ENGINE SECURITY ASSOCIATION STRUCTURE (CONTINUED)

| Name | | Bit 31/23/15/7 | Bit 30/22/14/6 | Bit 29/21/13/5 | Bit 28/20/12/4 | Bit 27/19/11/3 | Bit 26/18/10/2 | Bit 25/17/9/1 | Bit 24/16/8/0 |
|-----------|-------|-------------------|-------------------|-------------------|-------------------|-------------------|-------------------|------------------|------------------|
| SA_ENCIV1 | 31:24 | ENCIV<31:24> | | | | | | | |
| | 23:16 | ENCIV<23:16> | | | | | | | |
| | 15:8 | ENCIV<15:8> | | | | | | | |
| | 7:0 | ENCIV<7:0> | | | | | | | |
| SA_ENCIV2 | 31:24 | ENCIV<31:24> | | | | | | | |
| | 23:16 | ENCIV<23:16> | | | | | | | |
| | 15:8 | ENCIV<15:8> | | | | | | | |
| | 7:0 | ENCIV<7:0> | | | | | | | |
| SA_ENCIV3 | 31:24 | ENCIV<31:24> | | | | | | | |
| | 23:16 | ENCIV<23:16> | | | | | | | |
| | 15:8 | ENCIV<15:8> | | | | | | | |
| | 7:0 | ENCIV<7:0> | | | | | | | |
| SA_ENCIV4 | 31:24 | ENCIV<31:24> | | | | | | | |
| | 23:16 | ENCIV<23:16> | | | | | | | |
| | 15:8 | ENCIV<15:8> | | | | | | | |
| | 7:0 | ENCIV<7:0> | | | | | | | |

PIC32MZ Embedded Connectivity with Floating Point Unit (EF) Family

Figure 26-10 shows the Security Association control word structure.

The Crypto Engine fetches different structures for different flows and ensures that hardware fetches minimum words from SA required for processing. The structure is ready for hardware optimal data fetches.

FIGURE 26-10: FORMAT OF SA_CTRL

| Bit Range | Bit 31/23/15/7 | Bit 30/22/14/6 | Bit 29/21/13/5 | Bit 28/20/12/4 | Bit 27/19/11/3 | Bit 26/18/10/2 | Bit 25/17/9/1 | Bit 24/16/8/0 |
|-----------|----------------|----------------|----------------|----------------|-----------------|----------------|---------------|---------------|
| 31-24 | — | — | VERIFY | — | NO_RX | OR_EN | ICVONLY | IRFLAG |
| 23-16 | LNC | LOADIV | FB | FLAGS | — | — | — | ALGO<6> |
| 15-8 | ALGO<5:0> | | | | | | ENC | KEY SIZE<1> |
| 7-0 | KEY SIZE<0> | MULTITASK<2:0> | | | CRYPTOALGO<3:0> | | | |

bit 31-30 **Reserved:** Do not use

bit 29 **VERIFY:** NIST Procedure Verification Setting
1 = NIST procedures are to be used
0 = Do not use NIST procedures

bit 28 **Reserved:** Do not use

bit 27 **NO_RX:** Receive DMA Control Setting
1 = Only calculate ICV for authentication calculations
0 = Normal processing

bit 26 **OR_EN:** OR Register Bits Enable Setting
1 = OR the register bits with the internal value of the CSR register
0 = Normal processing

bit 25 **ICVONLY:** Incomplete Check Value Only Flag
This affects the SHA-1 algorithm only. It has no effect on the AES algorithm.
1 = Only three words of the HMAC result are available
0 = All results from the HMAC result are available

bit 24 **IRFLAG:** Immediate Result of Hash Setting
This bit is set when the immediate result for hashing is requested.
1 = Save the immediate result for hashing
0 = Do not save the immediate result

bit 23 **LNC:** Load New Keys Setting
1 = Load a new set of keys for encryption and authentication
0 = Do not load new keys

bit 22 **LOADIV:** Load IV Setting
1 = Load the IV from this Security Association
0 = Use the next IV

bit 21 **FB:** First Block Setting
This bit indicates that this is the first block of data to feed the IV value.
1 = Indicates this is the first block of data
0 = Indicates this is not the first block of data

bit 20 **FLAGS:** Incoming/Outgoing Flow Setting
1 = Security Association is associated with an outgoing flow
0 = Security Association is associated with an incoming flow

bit 19-17 **Reserved:** Do not use

PIC32MZ Embedded Connectivity with Floating Point Unit (EF) Family

Figure 26-10: Format of SA_CTRL (Continued)

| | |
|-----------|---|
| bit 16-10 | ALGO<6:0> : Type of Algorithm to Use 1xxxxxx = HMAC 1 x1xxxxx = SHA-256 xx1xxxx = SHA1 xxx1xxx = MD5 xxxx1xx = AES xxxxx1x = TDES xxxxxx1 = DES |
| bit 9 | ENC : Type of Encryption Setting 1 = Encryption 0 = Decryption |
| bit 8-7 | KEYSIZE<1:0> : Size of Keys in SA_AUTHKEYx or SA_ENCKEYx 11 = Reserved; do not use 10 = 256 bits 01 = 192 bits 00 = 128 bits ⁽¹⁾ |
| bit 6-4 | MULTITASK<2:0> : How to Combine Parallel Operations in the Crypto Engine 111 = Parallel pass (decrypt and authenticate incoming data in parallel) 101 = Pipe pass (encrypt the incoming data, and then perform authentication on the encrypted data) 011 = Reserved 010 = Reserved 001 = Reserved 000 = Encryption or authentication or decryption (no pass) |
| bit 3-0 | CRYPTOALGO<3:0> : Mode of operation for the Crypto Algorithm 1111 = Reserved 1110 = AES_GCM (for AES processing) 1101 = RCTR (for AES processing) 1100 = RCBC_MAC (for AES processing) 1011 = ROFB (for AES processing) 1010 = RCFB (for AES processing) 1001 = RCBC (for AES processing) 1000 = REBC (for AES processing) 0111 = TOFB (for Triple-DES processing) 0110 = TCFB (for Triple-DES processing) 0101 = TCBC (for Triple-DES processing) 0100 = TECB (for Triple-DES processing) 0011 = OFB (for DES processing) 0010 = CFB (for DES processing) 0001 = CBC (for DES processing) 0000 = ECB (for DES processing) |

Note 1: This setting does not alter the size of SA_AUTHKEYx or SA_ENCKEYx in the Security Association, only the number of bits of SA_AUTHKEYx and SA_ENCKEYx that are used.

27.0 RANDOM NUMBER GENERATOR (RNG)

Note: This data sheet summarizes the features of the PIC32MZ EF family of devices. It is not intended to be a comprehensive reference source. To complement the information in this data sheet, refer to **Section 49. “Crypto Engine (CE) and Random Number Generator (RNG)”** (DS60001246) in the “PIC32 Family Reference Manual”, which is available from the Microchip web site (www.microchip.com/PIC32).

The Random Number Generator (RNG) core implements a thermal noise-based, True Random Number Generator (TRNG) and a cryptographically secure Pseudo-Random Number Generator (PRNG).

The TRNG uses multiple ring oscillators and the inherent thermal noise of integrated circuits to generate true random numbers that can initialize the PRNG.

The PRNG is a flexible LSFR, which is capable of manifesting a maximal length LFSR of up to 64-bits.

The following are some of the key features of the Random Number Generator:

- TRNG:
 - Up to 25 Mbps of random bits
 - Multi-Ring Oscillator based design
 - Built-in Bias Corrector
- PRNG:
 - LSFR-based
 - Up to 64-bit polynomial length
 - Programmable polynomial
 - TRNG can be seed value

TABLE 27-1: RANDOM NUMBER GENERATOR BLOCK DIAGRAM

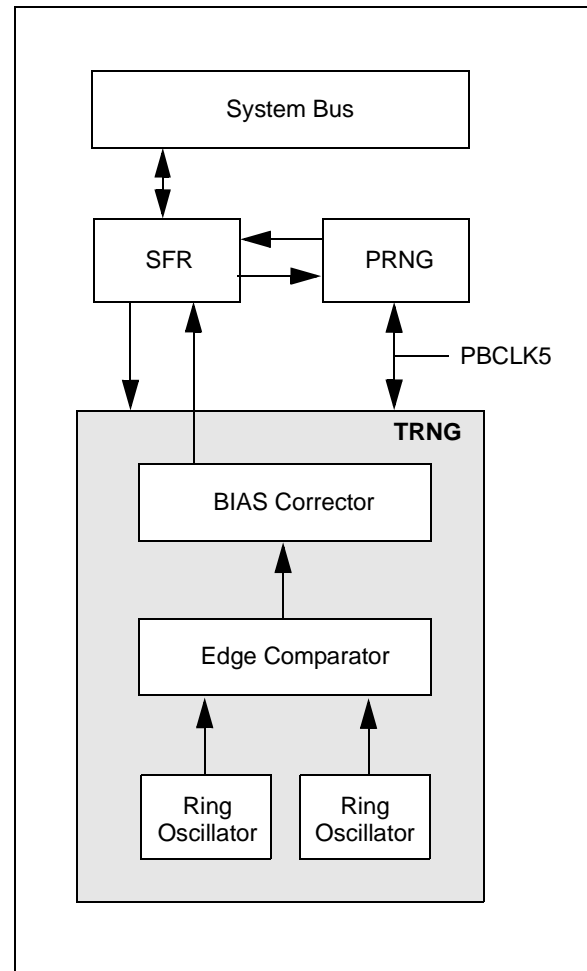

27.1 RNG Control Registers

TABLE 27-2: RANDOM NUMBER GENERATOR (RNG) REGISTER MAP

| Virtual Address (BF8E.#) | Register Name | Bit Range | Bits | | | | | | | | | | | | | | | All Resets | |
|-----------------------------|------------------|-----------|--------------|-------|-------|-------|----------|-------|--------|---------------|-----------|-----------|------|------|------|------|------|------------|------|
| | | | 31/15 | 30/14 | 29/13 | 28/12 | 27/11 | 26/10 | 25/9 | 24/8 | 23/7 | 22/6 | 21/5 | 20/4 | 19/3 | 18/2 | 17/1 | | 16/0 |
| 6000 | RNGVER | 31:16 | ID<15:0> | | | | | | | | | | | | | | | xxxx | |
| | | 15:0 | VERSION<7:0> | | | | | | | REVISION<7:0> | | | | | | | | xxxx | |
| 6004 | RNGCON | 31:16 | — | — | — | — | — | — | — | — | — | — | — | — | — | — | — | — | 0000 |
| | | 15:0 | — | — | — | LOAD | TRNGMODE | CONT | PRNGEN | TRNGEN | PLEN<7:0> | | | | | | | | 0064 |
| 6008 | RNGPOLY1 | 31:16 | POLY<31:0> | | | | | | | | | | | | | | | FFFF | |
| | | 15:0 | POLY<31:0> | | | | | | | | | | | | | | | 0000 | |
| 600C | RNGPOLY2 | 31:16 | POLY<31:0> | | | | | | | | | | | | | | | FFFF | |
| | | 15:0 | POLY<31:0> | | | | | | | | | | | | | | | 0000 | |
| 6010 | RNGNUMGEN1 | 31:16 | RNG<31:0> | | | | | | | | | | | | | | | FFFF | |
| | | 15:0 | RNG<31:0> | | | | | | | | | | | | | | | FFFF | |
| 6014 | RNGNUMGEN2 | 31:16 | RNG<31:0> | | | | | | | | | | | | | | | FFFF | |
| | | 15:0 | RNG<31:0> | | | | | | | | | | | | | | | FFFF | |
| 6018 | RNGSEED1 | 31:16 | SEED<31:0> | | | | | | | | | | | | | | | 0000 | |
| | | 15:0 | SEED<31:0> | | | | | | | | | | | | | | | 0000 | |
| 601C | RNGSEED2 | 31:16 | SEED<31:0> | | | | | | | | | | | | | | | 0000 | |
| | | 15:0 | SEED<31:0> | | | | | | | | | | | | | | | 0000 | |
| 6020 | RNGCNT | 31:16 | — | — | — | — | — | — | — | — | — | — | — | — | — | — | — | — | 0000 |
| | | 15:0 | — | — | — | — | — | — | — | — | — | RCNT<6:0> | | | | | | 0000 | |

Legend: x = unknown value on Reset; — = unimplemented, read as '0'. Reset values are shown in hexadecimal.

PIC32MZ Embedded Connectivity with Floating Point Unit (EF) Family

REGISTER 27-1: RNGVER: RANDOM NUMBER GENERATOR VERSION REGISTER

| Bit Range | Bit 31/23/15/7 | Bit 30/22/14/6 | Bit 29/21/13/5 | Bit 28/20/12/4 | Bit 27/19/11/3 | Bit 26/18/10/2 | Bit 25/17/9/1 | Bit 24/16/8/0 |
|---------------|----------------|----------------|----------------|----------------|----------------|----------------|---------------|---------------|
| 31:24 | R-0 | R-0 | R-0 | R-0 | R-0 | R-0 | R-0 | R-0 |
| ID<15:8> | | | | | | | | |
| 23:16 | R-0 | R-0 | R-0 | R-0 | R-0 | R-0 | R-0 | R-0 |
| ID<7:0> | | | | | | | | |
| 15:8 | R-0 | R-0 | R-0 | R-0 | R-0 | R-0 | R-0 | R-0 |
| VERSION<7:0> | | | | | | | | |
| 7:0 | R-0 | R-0 | R-0 | R-0 | R-0 | R-0 | R-0 | R-0 |
| REVISION<7:0> | | | | | | | | |

Legend:

R = Readable bit
-n = Value at POR

W = Writable bit
'1' = Bit is set

U = Unimplemented bit, read as '0'
'0' = Bit is cleared
x = Bit is unknown

- bit 31-16 **ID<15:0>**: Block Identification bits
- bit 15-8 **VERSION<7:0>**: Block Version bits
- bit 7-0 **REVISION<7:0>**: Block Revision bits

PIC32MZ Embedded Connectivity with Floating Point Unit (EF) Family

REGISTER 27-2: RNGCON: RANDOM NUMBER GENERATOR CONTROL REGISTER

| Bit Range | Bit 31/23/15/7 | Bit 30/22/14/6 | Bit 29/21/13/5 | Bit 28/20/12/4 | Bit 27/19/11/3 | Bit 26/18/10/2 | Bit 25/17/9/1 | Bit 24/16/8/0 |
|-----------|----------------|----------------|----------------|----------------|----------------|----------------|---------------|---------------|
| 31:24 | U-0 | U-0 | U-0 | U-0 | U-0 | U-0 | U-0 | U-0 |
| | — | — | — | — | — | — | — | — |
| 23:16 | U-0 | U-0 | U-0 | U-0 | U-0 | U-0 | U-0 | U-0 |
| | — | — | — | — | — | — | — | — |
| 15:8 | U-0 | U-0 | U-0 | R/W-0 | R/W-0 | R/W-0 | R/W-0 | R/W-0 |
| | — | — | — | LOAD | TRNGMODE | CONT | PRNGEN | TRNGEN |
| 7:0 | R/W-0 | R/W-1 | R/W-1 | R/W-0 | R/W-0 | R/W-1 | R/W-0 | R/W-0 |
| | PLEN<7:0> | | | | | | | |

Legend:

R = Readable bit

W = Writable bit

U = Unimplemented bit, read as '0'

-n = Value at POR

'1' = Bit is set

'0' = Bit is cleared

x = Bit is unknown

bit 31-13 **Unimplemented:** Read as '0'

bit 12 **LOAD:** Device Select bit

This bit is self-clearing and is used to load the seed from the TRNG (i.e., the random value) as a seed to the PRNG.

bit 11 **TRNGMODE:** TRNG Mode Selection bit

1 = Use ring oscillators with bias corrector
0 = Use ring oscillators with XOR tree

Note: Enabling this bit will generate numbers with a more even distribution of randomness.

bit 10 **CONT:** PRNG Number Shift Enable bit

1 = The PRNG random number is shifted every cycle
0 = The PRNG random number is shifted when the previous value is removed

bit 9 **PRNGEN:** PRNG Operation Enable bit

1 = PRNG operation is enabled
0 = PRNG operation is not enabled

bit 8 **TRNGEN:** TRNG Operation Enable bit

1 = TRNG operation is enabled
0 = TRNG operation is not enabled

bit 7-0 **PLEN<7:0>:** PRNG Polynomial Length bits

These bits contain the length of the polynomial used for the PRNG.

PIC32MZ Embedded Connectivity with Floating Point Unit (EF) Family

REGISTER 27-5: RNGSEEDx: TRUE RANDOM NUMBER GENERATOR SEED REGISTER 'x'
('x' = 1 OR 2)

| Bit Range | Bit 31/23/15/7 | Bit 30/22/14/6 | Bit 29/21/13/5 | Bit 28/20/12/4 | Bit 27/19/11/3 | Bit 26/18/10/2 | Bit 25/17/9/1 | Bit 24/16/8/0 |
|-----------|----------------|----------------|----------------|----------------|----------------|----------------|---------------|---------------|
| 31:24 | R-0 | R-0 | R-0 | R-0 | R-0 | R-0 | R-0 | R-0 |
| | SEED<31:24> | | | | | | | |
| 23:16 | R-0 | R-0 | R-0 | R-0 | R-0 | R-0 | R-0 | R-0 |
| | SEED<23:16> | | | | | | | |
| 15:8 | R-0 | R-0 | R-0 | R-0 | R-0 | R-0 | R-0 | R-0 |
| | SEED<15:8> | | | | | | | |
| 7:0 | R-0 | R-0 | R-0 | R-0 | R-0 | R-0 | R-0 | R-0 |
| | SEED<7:0> | | | | | | | |

Legend:

R = Readable bit W = Writable bit U = Unimplemented bit, read as '0'
 -n = Value at POR '1' = Bit is set '0' = Bit is cleared x = Bit is unknown

bit 31-0 **SEED<31:0>**: TRNG MSb/LSb Value bits (RNGSEED1 = LSb, RNGSEED2 = MSb)

REGISTER 27-6: RNGCNT: TRUE RANDOM NUMBER GENERATOR COUNT REGISTER

| Bit Range | Bit 31/23/15/7 | Bit 30/22/14/6 | Bit 29/21/13/5 | Bit 28/20/12/4 | Bit 27/19/11/3 | Bit 26/18/10/2 | Bit 25/17/9/1 | Bit 24/16/8/0 |
|-----------|----------------|----------------|----------------|----------------|----------------|----------------|---------------|---------------|
| 31:24 | U-0 | U-0 | U-0 | U-0 | U-0 | U-0 | U-0 | U-0 |
| | — | — | — | — | — | — | — | — |
| 23:16 | U-0 | U-0 | U-0 | U-0 | U-0 | U-0 | U-0 | U-0 |
| | — | — | — | — | — | — | — | — |
| 15:8 | U-0 | U-0 | U-0 | U-0 | U-0 | U-0 | U-0 | U-0 |
| | — | — | — | — | — | — | — | — |
| 7:0 | U-0 | R/W-0 | R/W-0 | R/W-0 | R/W-0 | R/W-0 | R/W-0 | R/W-0 |
| | — | RCNT<6:0> | | | | | | |

Legend:

R = Readable bit W = Writable bit U = Unimplemented bit, read as '0'
 -n = Value at POR '1' = Bit is set '0' = Bit is cleared x = Bit is unknown

bit 31-7 **Unimplemented:** Read as '0'

bit 6-0 **RCNT<6:0>**: Number of Valid TRNG MSB 32 bits

28.0 12-BIT HIGH-SPEED SUCCESSIVE APPROXIMATION REGISTER (SAR) ANALOG-TO-DIGITAL CONVERTER (ADC)

Note: This data sheet summarizes the features of the PIC32MZ EF family of devices. It is not intended to be a comprehensive reference source. To complement the information in this data sheet, refer to **Section 22. “12-bit High-Speed Successive Approximation Register (SAR) Analog-to-Digital Converter (ADC)”** (DS60001344) in the “*PIC32 Family Reference Manual*”, which is available from the Microchip web site (www.microchip.com/PIC32).

The 12-bit High-Speed Successive Approximation Register (SAR) Analog-to-Digital Converter (ADC) includes the following features:

- 12-bit resolution
- Six ADC modules with dedicated Sample and Hold (S&H) circuits
- Two dedicated ADC modules can be combined in Turbo mode to provide double conversion rate (clock sources for combined ADC modules must be synchronous)
- Single-ended and/or differential inputs
- Can operate during Sleep mode
- Supports touch sense applications
- Six digital comparators
- Six digital filters supporting two modes:
 - Oversampling mode
 - Averaging mode
- Early interrupt generation resulting in faster processing of converted data
- Designed for motor control, power conversion, and general purpose applications

A simplified block diagram of the ADC module is illustrated in [Figure 28-1](#).

The 12-bit HS SAR ADC has up to five dedicated ADC modules (ADC0-ADC4) and one shared ADC module (ADC7). The dedicated ADC modules use a single input (or its alternate) and are intended for high-speed and precise sampling of time-sensitive or transient inputs. The shared ADC module incorporates a multiplexer on the input to facilitate a larger group of inputs, with slower sampling, and provides flexible automated scanning option through the input scan logic.

For each ADC module, the analog inputs are connected to the S&H capacitor. The clock, sampling time, and output data resolution for each ADC module can be set independently. The ADC module performs the conversion of the input analog signal based on the configurations set in the registers. When conversion is complete, the final result is stored in the result buffer for the specific analog input and is passed to the digital filter and digital comparator if configured to use data from this particular sample. Input to ADCx mapping is illustrated in [Figure 28-2](#).

PIC32MZ Embedded Connectivity with Floating Point Unit (EF) Family

FIGURE 28-1: ADC BLOCK DIAGRAM

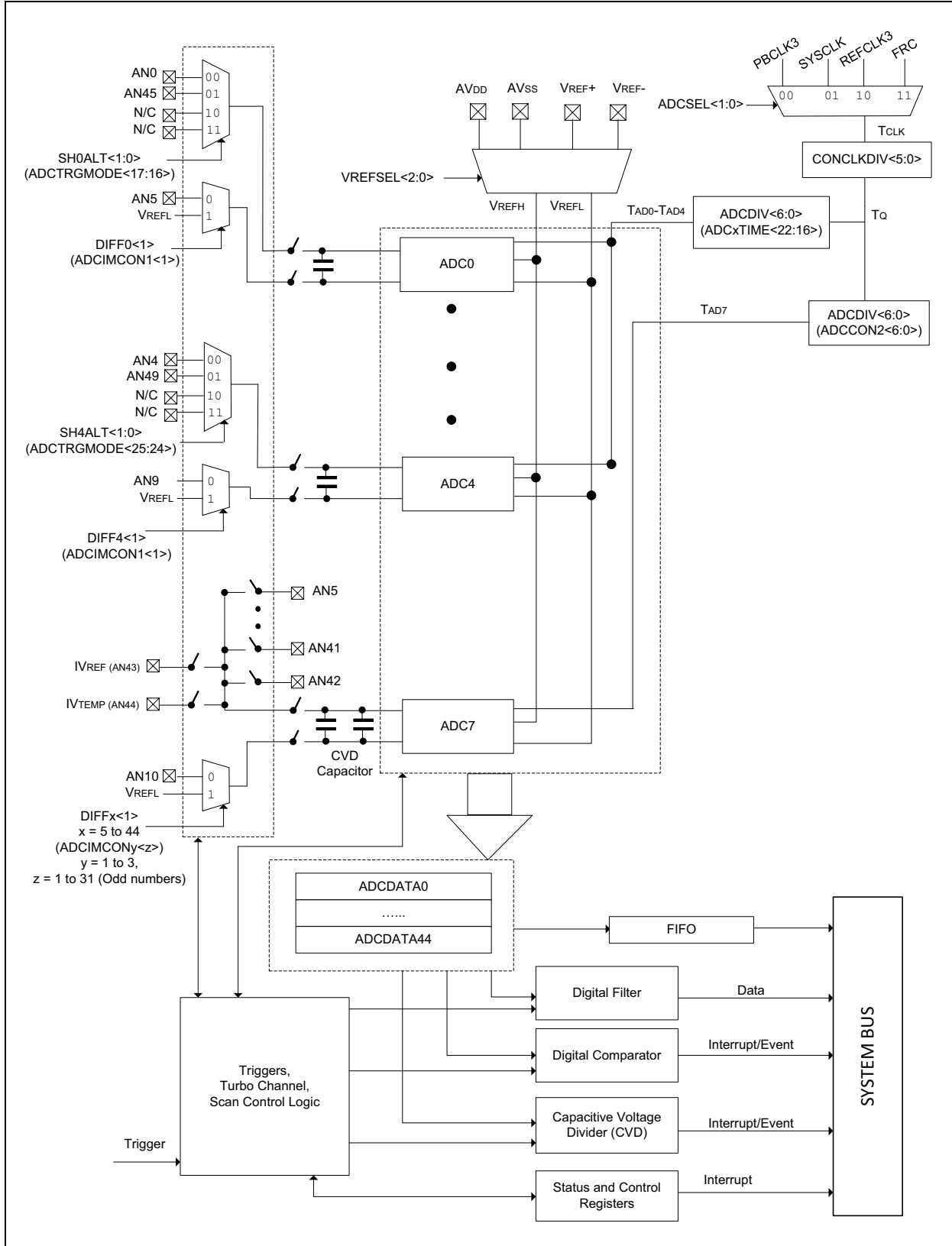

FIGURE 28-2: S&H BLOCK DIAGRAM

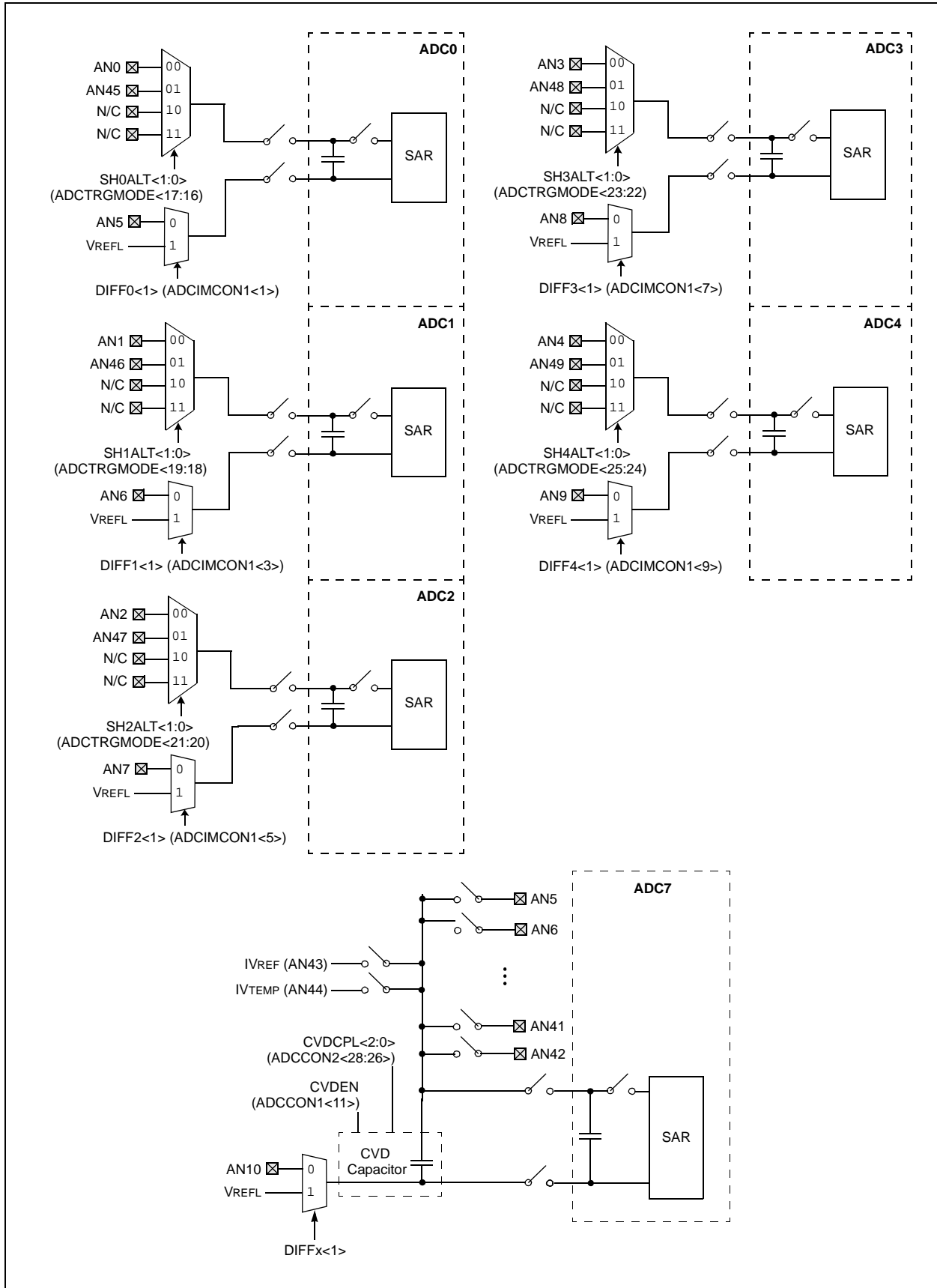
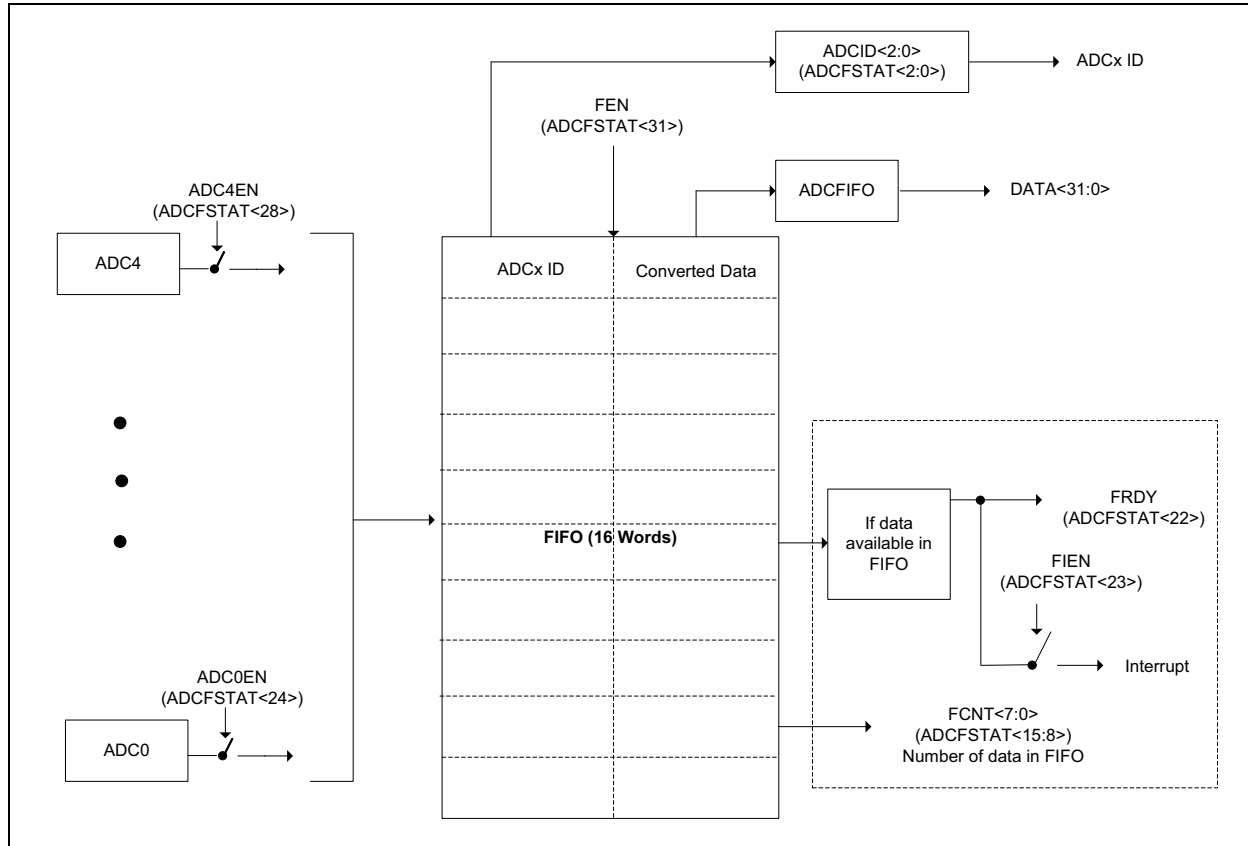

FIGURE 28-3: FIFO BLOCK DIAGRAM



28.1 ADC Control Registers

TABLE 28-1: ADC REGISTER MAP

| Virtual Address (BF84_#) | Register Name | Bit Range | Bits | | | | | | | | | | | | | | | All Resets | |
|--------------------------|---------------|-----------|------------------------|------------------------|------------------------|------------------------|------------------------|------------------------|------------------------|------------------------|------------------------|------------------------|------------------------|------------------------|------------------------|------------------------|------------------------|------------------------|------|
| | | | 31/15 | 30/14 | 29/13 | 28/12 | 27/11 | 26/10 | 25/9 | 24/8 | 23/7 | 22/6 | 21/5 | 20/4 | 19/3 | 18/2 | 17/1 | | 16/0 |
| B000 | ADCCON1 | 31:16 | TRBEN | TRBERR | TRBMST<2:0> | | | TRBSLV<2:0> | | | FRACT | SELRES<1:0> | | | STRGSRC<4:0> | | | | 0060 |
| | | 15:0 | ON | — | SIDL | — | CVDEN | FSSCLKEN | FSPBCLKEN | — | — | IRQVS<2:0> | | | STRGLVL | — | — | — | 1000 |
| B004 | ADCCON2 | 31:16 | BGVRDY | REFFLT | EOSRDY | CVDCPL<2:0> | | | SAMC<9:0> | | | | | | | 0000 | | | |
| | | 15:0 | BGVRIEN | REFFLTEN | EOSIEN | ADCEIOVR | — | ADCEIS<2:0> | | | — | ADCDIV<6:0> | | | | | 0000 | | |
| B008 | ADCCON3 | 31:16 | ADCSEL<1:0> | | CONCLDIV<5:0> | | | | | DIGEN7 | — | DIGEN4 | DIGEN3 | DIGEN2 | DIGEN1 | DIGEN0 | 0000 | | |
| | | 15:0 | VREFSEL<2:0> | | | TRGSUSP | UPDIEN | UPDRDY | SAMP | RQCNVRT | GLSWTRG | GSWTRG | ADINSEL<5:0> | | | | | 0000 | |
| B00C | ADCTRMODE | 31:16 | — | — | — | — | — | SH4ALT<1:0> | | | SH3ALT<1:0> | | SH2ALT<1:0> | | SH1ALT<1:0> | | SH0ALT<1:0> | 0000 | |
| | | 15:0 | — | — | — | STRGEN4 | STRGEN3 | STRGEN2 | STRGEN1 | STRGEN0 | — | — | — | SSAMPEN4 | SSAMPEN3 | SSAMPEN2 | SSAMPEN1 | SSAMPEN0 | 0000 |
| B010 | ADCMCON1 | 31:16 | DIFF15 | SIGN15 | DIFF14 | SIGN14 | DIFF13 | SIGN13 | DIFF12 | SIGN12 | DIFF11 | SIGN11 | DIFF10 | SIGN10 | DIFF9 | SIGN9 | DIFF8 | SIGN8 | 0000 |
| | | 15:0 | DIFF7 | SIGN7 | DIFF6 | SIGN6 | DIFF5 | SIGN5 | DIFF4 | SIGN4 | DIFF3 | SIGN3 | DIFF2 | SIGN2 | DIFF1 | SIGN1 | DIFF0 | SIGN0 | 0000 |
| B014 | ADCMCON2 | 31:16 | DIFF31 ⁽¹⁾ | SIGN31 ⁽¹⁾ | DIFF30 ⁽¹⁾ | SIGN30 ⁽¹⁾ | DIFF29 ⁽¹⁾ | SIGN29 ⁽¹⁾ | DIFF28 ⁽¹⁾ | SIGN28 ⁽¹⁾ | DIFF27 ⁽¹⁾ | SIGN27 ⁽¹⁾ | DIFF26 ⁽¹⁾ | SIGN26 ⁽¹⁾ | DIFF25 ⁽¹⁾ | SIGN25 ⁽¹⁾ | DIFF24 ⁽¹⁾ | SIGN24 ⁽¹⁾ | 0000 |
| | | 15:0 | DIFF23 ⁽¹⁾ | SIGN23 ⁽¹⁾ | DIFF22 ⁽¹⁾ | SIGN22 ⁽¹⁾ | DIFF21 ⁽¹⁾ | SIGN21 ⁽¹⁾ | DIFF20 ⁽¹⁾ | SIGN20 ⁽¹⁾ | DIFF19 ⁽¹⁾ | SIGN19 ⁽¹⁾ | DIFF18 | SIGN18 | DIFF17 | SIGN17 | DIFF16 | SIGN16 | 0000 |
| B018 | ADCMCON3 | 31:16 | — | — | — | — | — | — | DIFF44 | SIGN44 | DIFF43 | SIGN43 | DIFF42 ⁽²⁾ | SIGN42 ⁽²⁾ | DIFF41 ⁽²⁾ | SIGN41 ⁽²⁾ | DIFF40 ⁽²⁾ | SIGN40 ⁽²⁾ | 0000 |
| | | 15:0 | DIFF39 ⁽²⁾ | SIGN39 ⁽²⁾ | DIFF38 ⁽²⁾ | SIGN38 ⁽²⁾ | DIFF37 ⁽²⁾ | SIGN37 ⁽²⁾ | DIFF36 ⁽²⁾ | SIGN36 ⁽²⁾ | DIFF35 ⁽²⁾ | SIGN35 ⁽²⁾ | DIFF34 ⁽¹⁾ | SIGN34 ⁽¹⁾ | DIFF33 ⁽¹⁾ | SIGN33 ⁽¹⁾ | DIFF32 ⁽¹⁾ | SIGN32 ⁽¹⁾ | 0000 |
| B020 | ADCGIQEN1 | 31:16 | AGIEN31 ⁽¹⁾ | AGIEN30 ⁽¹⁾ | AGIEN29 ⁽¹⁾ | AGIEN28 ⁽¹⁾ | AGIEN27 ⁽¹⁾ | AGIEN26 ⁽¹⁾ | AGIEN25 ⁽¹⁾ | AGIEN24 ⁽¹⁾ | AGIEN23 ⁽¹⁾ | AGIEN22 ⁽¹⁾ | AGIEN21 ⁽¹⁾ | AGIEN20 ⁽¹⁾ | AGIEN19 ⁽¹⁾ | AGIEN18 | AGIEN17 | AGIEN16 | 0000 |
| | | 15:0 | AGIEN15 | AGIEN14 | AGIEN13 | AGIEN12 | AGIEN11 | AGIEN10 | AGIEN9 | AGIEN8 | AGIEN7 | AGIEN6 | AGIEN5 | AGIEN4 | AGIEN3 | AGIEN2 | AGIEN1 | AGIEN0 | 0000 |
| B024 | ADCGIQEN2 | 31:16 | — | — | — | — | — | — | — | — | — | — | — | — | — | — | — | — | 0000 |
| | | 15:0 | — | — | — | AGIEN44 | AGIEN43 | AGIEN42 ⁽²⁾ | AGIEN41 ⁽²⁾ | AGIEN40 ⁽²⁾ | AGIEN39 ⁽²⁾ | AGIEN38 ⁽²⁾ | AGIEN37 ⁽²⁾ | AGIEN36 ⁽²⁾ | AGIEN35 ⁽²⁾ | AGIEN34 ⁽¹⁾ | AGIEN33 ⁽¹⁾ | AGIEN32 ⁽¹⁾ | 0000 |
| B028 | ADCCSS1 | 31:16 | CSS31 ⁽¹⁾ | CSS30 ⁽¹⁾ | CSS29 ⁽¹⁾ | CSS28 ⁽¹⁾ | CSS27 ⁽¹⁾ | CSS26 ⁽¹⁾ | CSS25 ⁽¹⁾ | CSS24 ⁽¹⁾ | CSS23 ⁽¹⁾ | CSS22 ⁽¹⁾ | CSS21 ⁽¹⁾ | CSS20 ⁽¹⁾ | CSS19 ⁽¹⁾ | CSS18 | CSS17 | CSS16 | 0000 |
| | | 15:0 | CSS15 | CSS14 | CSS13 | CSS12 | CSS11 | CSS10 | CSS9 | CSS8 | CSS7 | CSS6 | CSS5 | CSS4 | CSS3 | CSS2 | CSS1 | CSS0 | 0000 |
| B02C | ADCCSS2 | 31:16 | — | — | — | — | — | — | — | — | — | — | — | — | — | — | — | — | 0000 |
| | | 15:0 | — | — | — | CSS44 | CSS43 | CSS42 ⁽²⁾ | CSS41 ⁽²⁾ | CSS40 ⁽²⁾ | CSS39 ⁽²⁾ | CSS38 ⁽²⁾ | CSS37 ⁽²⁾ | CSS36 ⁽²⁾ | CSS35 ⁽²⁾ | CSS34 ⁽¹⁾ | CSS33 ⁽¹⁾ | CSS32 ⁽¹⁾ | 0000 |
| B030 | ADCDSTAT1 | 31:16 | ARDY31 ⁽¹⁾ | ARDY30 ⁽¹⁾ | ARDY29 ⁽¹⁾ | ARDY28 ⁽¹⁾ | ARDY27 ⁽¹⁾ | ARDY26 ⁽¹⁾ | ARDY25 ⁽¹⁾ | ARDY24 ⁽¹⁾ | ARDY23 ⁽¹⁾ | ARDY22 ⁽¹⁾ | ARDY21 ⁽¹⁾ | ARDY20 ⁽¹⁾ | ARDY19 ⁽¹⁾ | ARDY18 | ARDY17 | ARDY16 | 0000 |
| | | 15:0 | ARDY15 | ARDY14 | ARDY13 | ARDY12 | ARDY11 | ARDY10 | ARDY9 | ARDY8 | ARDY7 | ARDY6 | ARDY5 | ARDY4 | ARDY3 | ARDY2 | ARDY1 | ARDY0 | 0000 |
| B034 | ADCDSTAT2 | 31:16 | — | — | — | — | — | — | — | — | — | — | — | — | — | — | — | — | 0000 |
| | | 15:0 | — | — | — | ARDY44 | ARDY43 | ARDY42 ⁽²⁾ | ARDY41 ⁽²⁾ | ARDY40 ⁽²⁾ | ARDY39 ⁽²⁾ | ARDY38 ⁽²⁾ | ARDY37 ⁽²⁾ | ARDY36 ⁽²⁾ | ARDY35 ⁽²⁾ | ARDY34 ⁽¹⁾ | ARDY33 ⁽¹⁾ | ARDY32 ⁽¹⁾ | 0000 |
| B038 | ADCCMPEN1 | 31:16 | CMPE31 ⁽¹⁾ | CMPE30 ⁽¹⁾ | CMPE29 ⁽¹⁾ | CMPE28 ⁽¹⁾ | CMPE27 ⁽¹⁾ | CMPE26 ⁽¹⁾ | CMPE25 ⁽¹⁾ | CMPE24 ⁽¹⁾ | CMPE23 ⁽¹⁾ | CMPE22 ⁽¹⁾ | CMPE21 ⁽¹⁾ | CMPE20 ⁽¹⁾ | CMPE19 ⁽¹⁾ | CMPE18 | CMPE17 | CMPE16 | 0000 |
| | | 15:0 | CMPE15 | CMPE14 | CMPE13 | CMPE12 | CMPE11 | CMPE10 | CMPE9 | CMPE8 | CMPE7 | CMPE6 | CMPE5 | CMPE4 | CMPE3 | CMPE2 | CMPE1 | CMPE0 | 0000 |
| B03C | ADCCMP1 | 31:16 | DCMPHI<15:0> | | | | | | | | | | | | | | | 0000 | |
| | | 15:0 | DCMPLO<15:0> | | | | | | | | | | | | | | | 0000 | |
| B040 | ADCCMPEN2 | 31:16 | CMPE31 ⁽¹⁾ | CMPE30 ⁽¹⁾ | CMPE29 ⁽¹⁾ | CMPE28 ⁽¹⁾ | CMPE27 ⁽¹⁾ | CMPE26 ⁽¹⁾ | CMPE25 ⁽¹⁾ | CMPE24 ⁽¹⁾ | CMPE23 ⁽¹⁾ | CMPE22 ⁽¹⁾ | CMPE21 ⁽¹⁾ | CMPE20 ⁽¹⁾ | CMPE19 ⁽¹⁾ | CMPE18 | CMPE17 | CMPE16 | 0000 |
| | | 15:0 | CMPE15 | CMPE14 | CMPE13 | CMPE12 | CMPE11 | CMPE10 | CMPE9 | CMPE8 | CMPE7 | CMPE6 | CMPE5 | CMPE4 | CMPE3 | CMPE2 | CMPE1 | CMPE0 | 0000 |
| B044 | ADCCMP2 | 31:16 | DCMPHI<15:0> | | | | | | | | | | | | | | | 0000 | |
| | | 15:0 | DCMPLO<15:0> | | | | | | | | | | | | | | | 0000 | |
| B048 | ADCCMPEN3 | 31:16 | CMPE31 ⁽¹⁾ | CMPE30 ⁽¹⁾ | CMPE29 ⁽¹⁾ | CMPE28 ⁽¹⁾ | CMPE27 ⁽¹⁾ | CMPE26 ⁽¹⁾ | CMPE25 ⁽¹⁾ | CMPE24 ⁽¹⁾ | CMPE23 ⁽¹⁾ | CMPE22 ⁽¹⁾ | CMPE21 ⁽¹⁾ | CMPE20 ⁽¹⁾ | CMPE19 ⁽¹⁾ | CMPE18 | CMPE17 | CMPE16 | 0000 |
| | | 15:0 | CMPE15 | CMPE14 | CMPE13 | CMPE12 | CMPE11 | CMPE10 | CMPE9 | CMPE8 | CMPE7 | CMPE6 | CMPE5 | CMPE4 | CMPE3 | CMPE2 | CMPE1 | CMPE0 | 0000 |

Note 1: This bit or register is not available on 64-pin devices.
 2: This bit or register is not available on 64-pin and 100-pin devices.

TABLE 28-1: ADC REGISTER MAP (CONTINUED)

| Virtual Address (BF84_#) | Register Name | Bit Range | Bits | | | | | | | | | | | | | | | All Resets | |
|-----------------------------|---------------|-----------|-----------------------|-----------------------|-----------------------|-----------------------|-----------------------|-----------------------|-----------------------|-----------------------|-----------------------|-----------------------|-----------------------|-----------------------|-----------------------|--------|--------|------------|------|
| | | | 31/15 | 30/14 | 29/13 | 28/12 | 27/11 | 26/10 | 25/9 | 24/8 | 23/7 | 22/6 | 21/5 | 20/4 | 19/3 | 18/2 | 17/1 | | 16/0 |
| B04C | ADCCMP3 | 31:16 | DCMPHI<15:0> | | | | | | | | | | | | | | | 0000 | |
| | | 15:0 | DCMPLO<15:0> | | | | | | | | | | | | | | | 0000 | |
| B050 | ADCCMPEN4 | 31:16 | CMPE31 ⁽¹⁾ | CMPE30 ⁽¹⁾ | CMPE29 ⁽¹⁾ | CMPE28 ⁽¹⁾ | CMPE27 ⁽¹⁾ | CMPE26 ⁽¹⁾ | CMPE25 ⁽¹⁾ | CMPE24 ⁽¹⁾ | CMPE23 ⁽¹⁾ | CMPE22 ⁽¹⁾ | CMPE21 ⁽¹⁾ | CMPE20 ⁽¹⁾ | CMPE19 ⁽¹⁾ | CMPE18 | CMPE17 | CMPE16 | 0000 |
| | | 15:0 | CMPE15 | CMPE14 | CMPE13 | CMPE12 | CMPE11 | CMPE10 | CMPE9 | CMPE8 | CMPE7 | CMPE6 | CMPE5 | CMPE4 | CMPE3 | CMPE2 | CMPE1 | CMPE0 | 0000 |
| B054 | ADCCMP4 | 31:16 | DCMPHI<15:0> | | | | | | | | | | | | | | | 0000 | |
| | | 15:0 | DCMPLO<15:0> | | | | | | | | | | | | | | | 0000 | |
| B058 | ADCCMPEN5 | 31:16 | CMPE31 ⁽¹⁾ | CMPE30 ⁽¹⁾ | CMPE29 ⁽¹⁾ | CMPE28 ⁽¹⁾ | CMPE27 ⁽¹⁾ | CMPE26 ⁽¹⁾ | CMPE25 ⁽¹⁾ | CMPE24 ⁽¹⁾ | CMPE23 ⁽¹⁾ | CMPE22 ⁽¹⁾ | CMPE21 ⁽¹⁾ | CMPE20 ⁽¹⁾ | CMPE19 ⁽¹⁾ | CMPE18 | CMPE17 | CMPE16 | 0000 |
| | | 15:0 | CMPE15 | CMPE14 | CMPE13 | CMPE12 | CMPE11 | CMPE10 | CMPE9 | CMPE8 | CMPE7 | CMPE6 | CMPE5 | CMPE4 | CMPE3 | CMPE2 | CMPE1 | CMPE0 | 0000 |
| B05C | ADCCMP5 | 31:16 | DCMPHI<15:0> | | | | | | | | | | | | | | | 0000 | |
| | | 15:0 | DCMPLO<15:0> | | | | | | | | | | | | | | | 0000 | |
| B060 | ADCCMPEN6 | 31:16 | CMPE31 ⁽¹⁾ | CMPE30 ⁽¹⁾ | CMPE29 ⁽¹⁾ | CMPE28 ⁽¹⁾ | CMPE27 ⁽¹⁾ | CMPE26 ⁽¹⁾ | CMPE25 ⁽¹⁾ | CMPE24 ⁽¹⁾ | CMPE23 ⁽¹⁾ | CMPE22 ⁽¹⁾ | CMPE21 ⁽¹⁾ | CMPE20 ⁽¹⁾ | CMPE19 ⁽¹⁾ | CMPE18 | CMPE17 | CMPE16 | 0000 |
| | | 15:0 | CMPE15 | CMPE14 | CMPE13 | CMPE12 | CMPE11 | CMPE10 | CMPE9 | CMPE8 | CMPE7 | CMPE6 | CMPE5 | CMPE4 | CMPE3 | CMPE2 | CMPE1 | CMPE0 | 0000 |
| B064 | ADCCMP6 | 31:16 | DCMPHI<15:0> | | | | | | | | | | | | | | | 0000 | |
| | | 15:0 | DCMPLO<15:0> | | | | | | | | | | | | | | | 0000 | |
| B068 | ADCFLTR1 | 31:16 | AFEN | DATA16EN | DFMODE | OVRSAM<2:0> | | | AFGIEN | AFRDY | — | — | — | CHNLID<4:0> | | | | 0000 | |
| | | 15:0 | FLTRDATA<15:0> | | | | | | | | | | | | | | | 0000 | |
| B06C | ADCFLTR2 | 31:16 | AFEN | DATA16EN | DFMODE | OVRSAM<2:0> | | | AFGIEN | AFRDY | — | — | — | CHNLID<4:0> | | | | 0000 | |
| | | 15:0 | FLTRDATA<15:0> | | | | | | | | | | | | | | | 0000 | |
| B070 | ADCFLTR3 | 31:16 | AFEN | DATA16EN | DFMODE | OVRSAM<2:0> | | | AFGIEN | AFRDY | — | — | — | CHNLID<4:0> | | | | 0000 | |
| | | 15:0 | FLTRDATA<15:0> | | | | | | | | | | | | | | | 0000 | |
| B074 | ADCFLTR4 | 31:16 | AFEN | DATA16EN | DFMODE | OVRSAM<2:0> | | | AFGIEN | AFRDY | — | — | — | CHNLID<4:0> | | | | 0000 | |
| | | 15:0 | FLTRDATA<15:0> | | | | | | | | | | | | | | | 0000 | |
| B078 | ADCFLTR5 | 31:16 | AFEN | DATA16EN | DFMODE | OVRSAM<2:0> | | | AFGIEN | AFRDY | — | — | — | CHNLID<4:0> | | | | 0000 | |
| | | 15:0 | FLTRDATA<15:0> | | | | | | | | | | | | | | | 0000 | |
| B07C | ADCFLTR6 | 31:16 | AFEN | DATA16EN | DFMODE | OVRSAM<2:0> | | | AFGIEN | AFRDY | — | — | — | CHNLID<4:0> | | | | 0000 | |
| | | 15:0 | FLTRDATA<15:0> | | | | | | | | | | | | | | | 0000 | |
| B080 | ADCTRG1 | 31:16 | — | — | — | TRGSRC3<4:0> | | | — | — | — | TRGSRC2<4:0> | | | | 0000 | | | |
| | | 15:0 | — | — | — | TRGSRC1<4:0> | | | — | — | — | TRGSRC0<4:0> | | | | 0000 | | | |
| B084 | ADCTRG2 | 31:16 | — | — | — | TRGSRC7<4:0> | | | — | — | — | TRGSRC6<4:0> | | | | 0000 | | | |
| | | 15:0 | — | — | — | TRGSRC5<4:0> | | | — | — | — | TRGSRC4<4:0> | | | | 0000 | | | |
| B088 | ADCTRG3 | 31:16 | — | — | — | TRGSRC11<4:0> | | | — | — | — | TRGSRC10<4:0> | | | | 0000 | | | |
| | | 15:0 | — | — | — | TRGSRC9<4:0> | | | — | — | — | TRGSRC8<4:0> | | | | 0000 | | | |
| B0A0 | ADCCMPCON1 | 31:16 | CVDDATA<15:0> | | | | | | | | | | | | | | | 0000 | |
| | | 15:0 | AINID<5:0> | | | | | ENDCMP | DCMPGIEN | DCMPED | IEBTWN | IEHIHI | IEHILO | IELOHI | IELOLO | 0000 | | | |
| B0A4 | ADCCMPCON2 | 31:16 | AINID<4:0> | | | | | ENDCMP | DCMPGIEN | DCMPED | IEBTWN | IEHIHI | IEHILO | IELOHI | IELOLO | 0000 | | | |
| | | 15:0 | AINID<4:0> | | | | | ENDCMP | DCMPGIEN | DCMPED | IEBTWN | IEHIHI | IEHILO | IELOHI | IELOLO | 0000 | | | |
| B0A8 | ADCCMPCON3 | 31:16 | AINID<4:0> | | | | | ENDCMP | DCMPGIEN | DCMPED | IEBTWN | IEHIHI | IEHILO | IELOHI | IELOLO | 0000 | | | |
| | | 15:0 | AINID<4:0> | | | | | ENDCMP | DCMPGIEN | DCMPED | IEBTWN | IEHIHI | IEHILO | IELOHI | IELOLO | 0000 | | | |

Note 1: This bit or register is not available on 64-pin devices.
 2: This bit or register is not available on 64-pin and 100-pin devices.

TABLE 28-1: ADC REGISTER MAP (CONTINUED)

| Virtual Address (BF84_#) | Register Name | Bit Range | Bits | | | | | | | | | | | | | | | | All Resets |
|-----------------------------|---------------|-----------|------------------------|------------------------|------------------------|------------------------|------------------------|------------------------|------------------------|------------------------|------------------------|------------------------|------------------------|------------------------|------------------------|------------------------|------------------------|------------------------|------------|
| | | | 31/15 | 30/14 | 29/13 | 28/12 | 27/11 | 26/10 | 25/9 | 24/8 | 23/7 | 22/6 | 21/5 | 20/4 | 19/3 | 18/2 | 17/1 | 16/0 | |
| B0AC | ADCCMPCON4 | 31:16 | — | — | — | — | — | — | — | — | — | — | — | — | — | — | — | — | 0000 |
| | | 15:0 | AINID<4:0> | | | | | | | | ENDCMP | DCMPGIEN | DCMPED | IEBTWN | IEHIHI | IEHILO | IELOHI | IELOLO | 0000 |
| B0B0 | ADCCMPCON5 | 31:16 | — | — | — | — | — | — | — | — | — | — | — | — | — | — | — | — | 0000 |
| | | 15:0 | AINID<4:0> | | | | | | | | ENDCMP | DCMPGIEN | DCMPED | IEBTWN | IEHIHI | IEHILO | IELOHI | IELOLO | 0000 |
| B0B4 | ADCCMPCON6 | 31:16 | — | — | — | — | — | — | — | — | — | — | — | — | — | — | — | — | 0000 |
| | | 15:0 | AINID<4:0> | | | | | | | | ENDCMP | DCMPGIEN | DCMPED | IEBTWN | IEHIHI | IEHILO | IELOHI | IELOLO | 0000 |
| B0B8 | ADCFSTAT | 31:16 | FEN | — | — | ADC4EN | ADC3EN | ADC2EN | ADC1EN | ADC0EN | FIEN | FRDY | FWROVERR | — | — | — | — | — | 0000 |
| | | 15:0 | FCNT<7:0> | | | | | | | | FSIGN | — | — | — | — | — | — | ADCCID<2:0> | 0000 |
| B0BC | ADCFIFO | 31:16 | DATA<31:16> | | | | | | | | | | | | | | | | 0000 |
| | | 15:0 | DATA<15:0> | | | | | | | | | | | | | | | | 0000 |
| B0C0 | ADCBASE | 31:16 | — | — | — | — | — | — | — | — | — | — | — | — | — | — | — | — | 0000 |
| | | 15:0 | ADCBASE<15:0> | | | | | | | | | | | | | | | | 0000 |
| B0D0 | ADCTRGSNS | 31:16 | — | — | — | — | — | — | — | — | — | — | — | — | — | — | — | — | 0000 |
| | | 15:0 | — | — | — | — | LVL11 | LVL10 | LVL9 | LVL8 | LVL7 | LVL6 | LVL5 | LVL4 | LVL3 | LVL2 | LVL1 | LVL0 | 0000 |
| B0D4 | ADC0TIME | 31:16 | — | — | — | — | ADCEIS<2:0> | | | SELRES<1:0> | | | — | ADCCDIV<6:0> | | | | | 0300 |
| | | 15:0 | — | — | — | — | — | — | — | — | — | SAMC<9:0> | | | | | 0000 | | |
| B0D8 | ADC1TIME | 31:16 | — | — | — | — | ADCEIS<2:0> | | | SELRES<1:0> | | | — | ADCCDIV<6:0> | | | | | 0300 |
| | | 15:0 | — | — | — | — | — | — | — | — | — | SAMC<9:0> | | | | | 0000 | | |
| B0DC | ADC2TIME | 31:16 | — | — | — | — | ADCEIS<2:0> | | | SELRES<1:0> | | | — | ADCCDIV<6:0> | | | | | 0300 |
| | | 15:0 | — | — | — | — | — | — | — | — | — | SAMC<9:0> | | | | | 0000 | | |
| B0E0 | ADC3TIME | 31:16 | — | — | — | — | ADCEIS<2:0> | | | SELRES<1:0> | | | — | ADCCDIV<6:0> | | | | | 0300 |
| | | 15:0 | — | — | — | — | — | — | — | — | — | SAMC<9:0> | | | | | 0000 | | |
| B0E4 | ADC4TIME | 31:16 | — | — | — | — | ADCEIS<2:0> | | | SELRES<1:0> | | | — | ADCCDIV<6:0> | | | | | 0300 |
| | | 15:0 | — | — | — | — | — | — | — | — | — | SAMC<9:0> | | | | | 0000 | | |
| B0F0 | ADCEIEN1 | 31:16 | EIEN31 ⁽¹⁾ | EIEN30 ⁽¹⁾ | EIEN29 ⁽¹⁾ | EIEN28 ⁽¹⁾ | EIEN27 ⁽¹⁾ | EIEN26 ⁽¹⁾ | EIEN25 ⁽¹⁾ | EIEN24 ⁽¹⁾ | EIEN23 ⁽¹⁾ | EIEN22 ⁽¹⁾ | EIEN21 ⁽¹⁾ | EIEN20 ⁽¹⁾ | EIEN19 ⁽¹⁾ | EIEN18 | EIEN17 | EIEN16 | 0000 |
| | | 15:0 | EIEN15 | EIEN14 | EIEN13 | EIEN12 | EIEN11 | EIEN10 | EIEN9 | EIEN8 | EIEN7 | EIEN6 | EIEN5 | EIEN4 | EIEN3 | EIEN2 | EIEN1 | EIEN0 | 0000 |
| B0F4 | ADCEIEN2 | 31:16 | — | — | — | — | — | — | — | — | — | — | — | — | — | — | — | — | 0000 |
| | | 15:0 | — | — | — | EIEN44 | EIEN43 | EIEN42 ⁽²⁾ | EIEN41 ⁽²⁾ | EIEN40 ⁽²⁾ | EIEN39 ⁽²⁾ | EIEN38 ⁽²⁾ | EIEN37 ⁽²⁾ | EIEN36 ⁽²⁾ | EIEN35 ⁽²⁾ | EIEN34 ⁽¹⁾ | EIEN33 ⁽¹⁾ | EIEN32 ⁽¹⁾ | 0000 |
| B0F8 | ADCEISTAT1 | 31:16 | EIRDY31 ⁽¹⁾ | EIRDY30 ⁽¹⁾ | EIRDY29 ⁽¹⁾ | EIRDY28 ⁽¹⁾ | EIRDY27 ⁽¹⁾ | EIRDY26 ⁽¹⁾ | EIRDY25 ⁽¹⁾ | EIRDY24 ⁽¹⁾ | EIRDY23 ⁽¹⁾ | EIRDY22 ⁽¹⁾ | EIRDY21 ⁽¹⁾ | EIRDY20 ⁽¹⁾ | EIRDY19 ⁽¹⁾ | EIRDY18 | EIRDY17 | EIRDY16 | 0000 |
| | | 15:0 | EIRDY15 | EIRDY14 | EIRDY13 | EIRDY12 | EIRDY11 | EIRDY10 | EIRDY9 | EIRDY8 | EIRDY7 | EIRDY6 | EIRDY5 | EIRDY4 | EIRDY3 | EIRDY2 | EIRDY1 | EIRDY0 | 0000 |
| B0FC | ADCEISTAT2 | 31:16 | — | — | — | — | — | — | — | — | — | — | — | — | — | — | — | — | 0000 |
| | | 15:0 | — | — | — | EIRDY44 | EIRDY43 | EIRDY42 ⁽²⁾ | EIRDY41 ⁽²⁾ | EIRDY40 ⁽²⁾ | EIRDY39 ⁽²⁾ | EIRDY38 ⁽²⁾ | EIRDY37 ⁽²⁾ | EIRDY36 ⁽²⁾ | EIRDY35 ⁽²⁾ | EIRDY34 ⁽¹⁾ | EIRDY33 ⁽¹⁾ | EIRDY32 ⁽¹⁾ | 0000 |
| B100 | ADCANCON | 31:16 | WKUPCLKCNT<3:0> | | | | | | | | | | | | | | | | 0000 |
| | | 15:0 | WKRDY7 | — | — | WKRDY4 | WKRDY3 | WKRDY2 | WKRDY1 | WKRDY0 | WKIEN7 | — | — | WKIEN4 | WKIEN3 | WKIEN2 | WKIEN1 | WKIEN0 | 0000 |
| B180 | ADC0CFG | 31:16 | ADCCFG<31:16> | | | | | | | | | | | | | | | | 0000 |
| | | 15:0 | ADCCFG<15:0> | | | | | | | | | | | | | | | | 0000 |
| B184 | ADC1CFG | 31:16 | ADCCFG<31:16> | | | | | | | | | | | | | | | | 0000 |
| | | 15:0 | ADCCFG<15:0> | | | | | | | | | | | | | | | | 0000 |

Note 1: This bit or register is not available on 64-pin devices.
 2: This bit or register is not available on 64-pin and 100-pin devices.

TABLE 28-1: ADC REGISTER MAP (CONTINUED)

| Virtual Address (BF84_#) | Register Name | Bit Range | Bits | | | | | | | | | | | | | | All Resets | | |
|-----------------------------|---------------|-----------|---------------|-------|-------|-----------|-------|-------|------|------|------|------|------|------|------|------|------------|------|------|
| | | | 31/15 | 30/14 | 29/13 | 28/12 | 27/11 | 26/10 | 25/9 | 24/8 | 23/7 | 22/6 | 21/5 | 20/4 | 19/3 | 18/2 | | 17/1 | 16/0 |
| B188 | ADC2CFG | 31:16 | ADCCFG<31:16> | | | | | | | | | | | | | | 0000 | | |
| | | 15:0 | ADCCFG<15:0> | | | | | | | | | | | | | | 0000 | | |
| B18C | ADC3CFG | 31:16 | ADCCFG<31:16> | | | | | | | | | | | | | | 0000 | | |
| | | 15:0 | ADCCFG<15:0> | | | | | | | | | | | | | | 0000 | | |
| B190 | ADC4CFG | 31:16 | ADCCFG<31:16> | | | | | | | | | | | | | | 0000 | | |
| | | 15:0 | ADCCFG<15:0> | | | | | | | | | | | | | | 0000 | | |
| B19C | ADC7CFG | 31:16 | ADCCFG<31:16> | | | | | | | | | | | | | | 0000 | | |
| | | 15:0 | ADCCFG<15:0> | | | | | | | | | | | | | | 0000 | | |
| B1C0 | ADCSYSCFG0 | 31:16 | AN<31:16> | | | | | | | | | | | | | | xxxF | | |
| | | 15:0 | AN<15:0> | | | | | | | | | | | | | | FFF | | |
| B1C4 | ADCSYSCFG1 | 31:16 | — | — | — | — | — | — | — | — | — | — | — | — | — | — | — | — | 0000 |
| | | 15:0 | — | — | — | AN<44:32> | | | | | | | | | | | 1xxx | | |
| B200 | ADCDATA0 | 31:16 | DATA<31:16> | | | | | | | | | | | | | | 0000 | | |
| | | 15:0 | DATA<15:0> | | | | | | | | | | | | | | 0000 | | |
| B204 | ADCDATA1 | 31:16 | DATA<31:16> | | | | | | | | | | | | | | 0000 | | |
| | | 15:0 | DATA<15:0> | | | | | | | | | | | | | | 0000 | | |
| B208 | ADCDATA2 | 31:16 | DATA<31:16> | | | | | | | | | | | | | | 0000 | | |
| | | 15:0 | DATA<15:0> | | | | | | | | | | | | | | 0000 | | |
| B20C | ADCDATA3 | 31:16 | DATA<31:16> | | | | | | | | | | | | | | 0000 | | |
| | | 15:0 | DATA<15:0> | | | | | | | | | | | | | | 0000 | | |
| B210 | ADCDATA4 | 31:16 | DATA<31:16> | | | | | | | | | | | | | | 0000 | | |
| | | 15:0 | DATA<15:0> | | | | | | | | | | | | | | 0000 | | |
| B214 | ADCDATA5 | 31:16 | DATA<31:16> | | | | | | | | | | | | | | 0000 | | |
| | | 15:0 | DATA<15:0> | | | | | | | | | | | | | | 0000 | | |
| B218 | ADCDATA6 | 31:16 | DATA<31:16> | | | | | | | | | | | | | | 0000 | | |
| | | 15:0 | DATA<15:0> | | | | | | | | | | | | | | 0000 | | |
| B21C | ADCDATA7 | 31:16 | DATA<31:16> | | | | | | | | | | | | | | 0000 | | |
| | | 15:0 | DATA<15:0> | | | | | | | | | | | | | | 0000 | | |
| B220 | ADCDATA8 | 31:16 | DATA<31:16> | | | | | | | | | | | | | | 0000 | | |
| | | 15:0 | DATA<15:0> | | | | | | | | | | | | | | 0000 | | |
| B224 | ADCDATA9 | 31:16 | DATA<31:16> | | | | | | | | | | | | | | 0000 | | |
| | | 15:0 | DATA<15:0> | | | | | | | | | | | | | | 0000 | | |
| B228 | ADCDATA10 | 31:16 | DATA<31:16> | | | | | | | | | | | | | | 0000 | | |
| | | 15:0 | DATA<15:0> | | | | | | | | | | | | | | 0000 | | |
| B22C | ADCDATA11 | 31:16 | DATA<31:16> | | | | | | | | | | | | | | 0000 | | |
| | | 15:0 | DATA<15:0> | | | | | | | | | | | | | | 0000 | | |
| B230 | ADCDATA12 | 31:16 | DATA<31:16> | | | | | | | | | | | | | | 0000 | | |
| | | 15:0 | DATA<15:0> | | | | | | | | | | | | | | 0000 | | |

Note 1: This bit or register is not available on 64-pin devices.
 2: This bit or register is not available on 64-pin and 100-pin devices.

TABLE 28-1: ADC REGISTER MAP (CONTINUED)

| Virtual Address (BF84_#) | Register Name | Bit Range | Bits | | | | | | | | | | | | | | All Resets |
|-----------------------------|--------------------------|-----------|-------------|-------|-------|-------|-------|-------|------|------|------|------|------|------|------|------|------------|
| | | | 31/15 | 30/14 | 29/13 | 28/12 | 27/11 | 26/10 | 25/9 | 24/8 | 23/7 | 22/6 | 21/5 | 20/4 | 19/3 | 18/2 | |
| B234 | ADCDATA13 | 31:16 | DATA<31:16> | | | | | | | | | | | | | | 0000 |
| | | 15:0 | DATA<15:0> | | | | | | | | | | | | | | 0000 |
| B238 | ADCDATA14 | 31:16 | DATA<31:16> | | | | | | | | | | | | | | 0000 |
| | | 15:0 | DATA<15:0> | | | | | | | | | | | | | | 0000 |
| B23C | ADCDATA15 | 31:16 | DATA<31:16> | | | | | | | | | | | | | | 0000 |
| | | 15:0 | DATA<15:0> | | | | | | | | | | | | | | 0000 |
| B240 | ADCDATA16 | 31:16 | DATA<31:16> | | | | | | | | | | | | | | 0000 |
| | | 15:0 | DATA<15:0> | | | | | | | | | | | | | | 0000 |
| B244 | ADCDATA17 | 31:16 | DATA<31:16> | | | | | | | | | | | | | | 0000 |
| | | 15:0 | DATA<15:0> | | | | | | | | | | | | | | 0000 |
| B248 | ADCDATA18 | 31:16 | DATA<31:16> | | | | | | | | | | | | | | 0000 |
| | | 15:0 | DATA<15:0> | | | | | | | | | | | | | | 0000 |
| B24C | ADCDATA19 ⁽¹⁾ | 31:16 | DATA<31:16> | | | | | | | | | | | | | | 0000 |
| | | 15:0 | DATA<15:0> | | | | | | | | | | | | | | 0000 |
| B250 | ADCDATA20 ⁽¹⁾ | 31:16 | DATA<31:16> | | | | | | | | | | | | | | 0000 |
| | | 15:0 | DATA<15:0> | | | | | | | | | | | | | | 0000 |
| B254 | ADCDATA21 ⁽¹⁾ | 31:16 | DATA<31:16> | | | | | | | | | | | | | | 0000 |
| | | 15:0 | DATA<15:0> | | | | | | | | | | | | | | 0000 |
| B258 | ADCDATA22 ⁽¹⁾ | 31:16 | DATA<31:16> | | | | | | | | | | | | | | 0000 |
| | | 15:0 | DATA<15:0> | | | | | | | | | | | | | | 0000 |
| B25C | ADCDATA23 ⁽¹⁾ | 31:16 | DATA<31:16> | | | | | | | | | | | | | | 0000 |
| | | 15:0 | DATA<15:0> | | | | | | | | | | | | | | 0000 |
| B260 | ADCDATA24 ⁽¹⁾ | 31:16 | DATA<31:16> | | | | | | | | | | | | | | 0000 |
| | | 15:0 | DATA<15:0> | | | | | | | | | | | | | | 0000 |
| B264 | ADCDATA25 ⁽¹⁾ | 31:16 | DATA<31:16> | | | | | | | | | | | | | | 0000 |
| | | 15:0 | DATA<15:0> | | | | | | | | | | | | | | 0000 |
| B268 | ADCDATA26 ⁽¹⁾ | 31:16 | DATA<31:16> | | | | | | | | | | | | | | 0000 |
| | | 15:0 | DATA<15:0> | | | | | | | | | | | | | | 0000 |
| B26C | ADCDATA27 ⁽¹⁾ | 31:16 | DATA<31:16> | | | | | | | | | | | | | | 0000 |
| | | 15:0 | DATA<15:0> | | | | | | | | | | | | | | 0000 |
| B270 | ADCDATA28 ⁽¹⁾ | 31:16 | DATA<31:16> | | | | | | | | | | | | | | 0000 |
| | | 15:0 | DATA<15:0> | | | | | | | | | | | | | | 0000 |
| B274 | ADCDATA29 ⁽¹⁾ | 31:16 | DATA<31:16> | | | | | | | | | | | | | | 0000 |
| | | 15:0 | DATA<15:0> | | | | | | | | | | | | | | 0000 |
| B278 | ADCDATA30 ⁽¹⁾ | 31:16 | DATA<31:16> | | | | | | | | | | | | | | 0000 |
| | | 15:0 | DATA<15:0> | | | | | | | | | | | | | | 0000 |
| B27C | ADCDATA31 ⁽¹⁾ | 31:16 | DATA<31:16> | | | | | | | | | | | | | | 0000 |
| | | 15:0 | DATA<15:0> | | | | | | | | | | | | | | 0000 |

Note 1: This bit or register is not available on 64-pin devices.
 2: This bit or register is not available on 64-pin and 100-pin devices.

TABLE 28-1: ADC REGISTER MAP (CONTINUED)

| Virtual Address (BF84_#) | Register Name | Bit Range | Bits | | | | | | | | | | | | | | All Resets |
|-----------------------------|--------------------------|-----------|-------------|-------|-------|-------|-------|-------|------|------|------|------|------|------|------|------|------------|
| | | | 31/15 | 30/14 | 29/13 | 28/12 | 27/11 | 26/10 | 25/9 | 24/8 | 23/7 | 22/6 | 21/5 | 20/4 | 19/3 | 18/2 | |
| B280 | ADCDATA32 ⁽¹⁾ | 31:16 | DATA<31:16> | | | | | | | | | | | | | | 0000 |
| | | 15:0 | DATA<15:0> | | | | | | | | | | | | | | 0000 |
| B284 | ADCDATA33 ⁽¹⁾ | 31:16 | DATA<31:16> | | | | | | | | | | | | | | 0000 |
| | | 15:0 | DATA<15:0> | | | | | | | | | | | | | | 0000 |
| B288 | ADCDATA34 ⁽¹⁾ | 31:16 | DATA<31:16> | | | | | | | | | | | | | | 0000 |
| | | 15:0 | DATA<15:0> | | | | | | | | | | | | | | 0000 |
| B28C | ADCDATA35 ⁽²⁾ | 31:16 | DATA<31:16> | | | | | | | | | | | | | | 0000 |
| | | 15:0 | DATA<15:0> | | | | | | | | | | | | | | 0000 |
| B290 | ADCDATA36 ⁽²⁾ | 31:16 | DATA<31:16> | | | | | | | | | | | | | | 0000 |
| | | 15:0 | DATA<15:0> | | | | | | | | | | | | | | 0000 |
| B294 | ADCDATA37 ⁽²⁾ | 31:16 | DATA<31:16> | | | | | | | | | | | | | | 0000 |
| | | 15:0 | DATA<15:0> | | | | | | | | | | | | | | 0000 |
| B298 | ADCDATA38 ⁽²⁾ | 31:16 | DATA<31:16> | | | | | | | | | | | | | | 0000 |
| | | 15:0 | DATA<15:0> | | | | | | | | | | | | | | 0000 |
| B29C | ADCDATA39 ⁽²⁾ | 31:16 | DATA<31:16> | | | | | | | | | | | | | | 0000 |
| | | 15:0 | DATA<15:0> | | | | | | | | | | | | | | 0000 |
| B2A0 | ADCDATA40 ⁽²⁾ | 31:16 | DATA<31:16> | | | | | | | | | | | | | | 0000 |
| | | 15:0 | DATA<15:0> | | | | | | | | | | | | | | 0000 |
| B2A4 | ADCDATA41 ⁽²⁾ | 31:16 | DATA<31:16> | | | | | | | | | | | | | | 0000 |
| | | 15:0 | DATA<15:0> | | | | | | | | | | | | | | 0000 |
| B2A8 | ADCDATA42 ⁽²⁾ | 31:16 | DATA<31:16> | | | | | | | | | | | | | | 0000 |
| | | 15:0 | DATA<15:0> | | | | | | | | | | | | | | 0000 |
| B2AC | ADCDATA43 | 31:16 | DATA<31:16> | | | | | | | | | | | | | | 0000 |
| | | 15:0 | DATA<15:0> | | | | | | | | | | | | | | 0000 |
| B2B0 | ADCDATA44 | 31:16 | DATA<31:16> | | | | | | | | | | | | | | 0000 |
| | | 15:0 | DATA<15:0> | | | | | | | | | | | | | | 0000 |

Note 1: This bit or register is not available on 64-pin devices.
 2: This bit or register is not available on 64-pin and 100-pin devices.

PIC32MZ Embedded Connectivity with Floating Point Unit (EF) Family

REGISTER 28-1: ADCCON1: ADC CONTROL REGISTER 1

| Bit Range | Bit 31/23/15/7 | Bit 30/22/14/6 | Bit 29/21/13/5 | Bit 28/20/12/4 | Bit 27/19/11/3 | Bit 26/18/10/2 | Bit 25/17/9/1 | Bit 24/16/8/0 |
|-----------|----------------|----------------|----------------|----------------|----------------|----------------|---------------|---------------|
| 31:24 | R/W-0 | R-0, HS, HC | R/W-0 | R/W-0 | R/W-0 | R/W-0 | R/W-0 | R/W-0 |
| | TRBEN | TRBERR | TRBMST<2:0> | | | TRBSLV<2:0> | | |
| 23:16 | R/W-0 | R/W-1 | R/W-1 | R/W-0 | R/W-0 | R/W-0 | R/W-0 | R/W-0 |
| | FRACT | SELRES<1:0> | | STRGSRC<4:0> | | | | |
| 15:8 | R/W-0 | U-0 | R/W-0 | r-1 | R/W-0 | R/W-0 | R/W-0 | U-0 |
| | ON | | SIDL | — | CVDEN | FSSCLKEN | FSPBCLKEN | — |
| 7:0 | U-0 | R/W-0 | R/W-0 | R/W-0 | R/W-0 | U-0 | U-0 | U-0 |
| | — | IRQVS<2:0> | | | STRGLVL | — | — | — |

| | | |
|-------------------|-------------------|--|
| Legend: | HC = Hardware Set | HS = Hardware Cleared |
| R = Readable bit | W = Writable bit | U = Unimplemented bit, read as '0' |
| -n = Value at POR | '1' = Bit is set | '0' = Bit is cleared x = Bit is unknown |

bit 31 **TRBEN:** Turbo Channel Enable bit

- 1 = Enable the Turbo channel
- 0 = Disable the Turbo channel

bit 30 **TRBERR:** Turbo Channel Error Status bit

- 1 = An error occurred while setting the Turbo channel and Turbo channel function to be disabled regardless of the TRBEN bit being set to '1'.
- 0 = Turbo channel error did not occur

Note: The status of this bit is valid only after the TRBEN bit is set.

bit 29-27 **TRBMST<2:0>:** Turbo Master ADCx bits

- 111 = Reserved
- 110 = ADC4 is selected as the Turbo Master
-
-
- 000 = ADC0 is selected as the Turbo Master

bit 26-24 **TRBSLV<2:0>:** Turbo Slave ADCx bits

- 111 = Reserved
- 110 = ADC4 is selected as the Turbo Slave
-
-
- 000 = ADC0 is selected as the Turbo Slave

bit 23 **FRACT:** Fractional Data Output Format bit

- 1 = Fractional
- 0 = Integer

bit 22-21 **SELRES<1:0>:** Shared ADC (ADC7) Resolution bits

- 11 = 12 bits (default)
- 10 = 10 bits
- 01 = 8 bits
- 00 = 6 bits

PIC32MZ Embedded Connectivity with Floating Point Unit (EF) Family

REGISTER 28-1: ADCCON1: ADC CONTROL REGISTER 1 (CONTINUED)

bit 20-16 **STRGSRC<4:0>**: Scan Trigger Source Select bits

11111 = Reserved

•
•
•

01101 = Reserved

01100 = Comparator 2 (COUT)

01011 = Comparator 1 (COUT)

01010 = OCMP5

01001 = OCMP3

01000 = OCMP1

00111 = TMR5 match

00110 = TMR3 match

00101 = TMR1 match

00100 = INT0 External interrupt

00011 = Reserved

00010 = Global level software trigger (GLSWTRG)

00001 = Global software edge trigger (GSWTRG)

00000 = No Trigger

bit 15 **ON**: ADC Module Enable bit

1 = ADC module is enabled

0 = ADC module is disabled

Note: The ON bit should be set only after the ADC module has been configured.

bit 14 **Unimplemented**: Read as '0'

bit 13 **SIDL**: Stop in Idle Mode bit

1 = Discontinue module operation when device enters Idle mode

0 = Continue module operation in Idle mode

bit 12 **Reserved**: Read as '1'; must be written as '1'.

bit 11 **CVDEN**: Capacitive Voltage Division Enable bit

1 = CVD operation is enabled

0 = CVD operation is disabled

bit 10 **FSSCLKEN**: Fast Synchronous System Clock to ADC Control Clock bit

1 = Fast synchronous system clock to ADC control clock is enabled

0 = Fast synchronous system clock to ADC control clock is disabled

bit 9 **FSPBCLKEN**: Fast Synchronous Peripheral Clock to ADC Control Clock bit

1 = Fast synchronous peripheral clock to ADC control clock is enabled

0 = Fast synchronous peripheral clock to ADC control clock is disabled

bit 8-7 **Unimplemented**: Read as '0'

bit 6-4 **IRQVS<2:0>**: Interrupt Vector Shift bits

To determine interrupt vector address, this bit specifies the amount of left shift done to the ARDYx status bits in the ADCDSTAT1 and ADCDSTAT2 registers, prior to adding with the ADCBASE register.

Interrupt Vector Address = Read Value of ADCBASE and Read Value of ADCBASE = Value written to ADCBASE + x << IRQVS<2:0>, where 'x' is the smallest active input ID from the ADCDSTAT1 or ADCDSTAT2 registers (which has highest priority).

111 = Shift x left 7 bit position

110 = Shift x left 6 bit position

101 = Shift x left 5 bit position

100 = Shift x left 4 bit position

011 = Shift x left 3 bit position

010 = Shift x left 2 bit position

001 = Shift x left 1 bit position

000 = Shift x left 0 bit position

PIC32MZ Embedded Connectivity with Floating Point Unit (EF) Family

REGISTER 28-1: ADCCON1: ADC CONTROL REGISTER 1 (CONTINUED)

- bit 3 **STRGLVL:** Scan Trigger High Level/Positive Edge Sensitivity bit
 1 = Scan trigger is high level sensitive. Once STRIG mode is selected (TRGSRCx<4:0> in the ADCTRGx register), the scan trigger will continue for all selected analog inputs, until the STRIG option is removed.
 0 = Scan trigger is positive edge sensitive. Once STRIG mode is selected (TRGSRCx<4:0> in the ADCTRGx register), only a single scan trigger will be generated, which will complete the scan of all selected analog inputs.
- bit 2-0 **Unimplemented:** Read as '0'

PIC32MZ Embedded Connectivity with Floating Point Unit (EF) Family

REGISTER 28-2: ADCCON2: ADC CONTROL REGISTER 2

| Bit Range | Bit 31/23/15/7 | Bit 30/22/14/6 | Bit 29/21/13/5 | Bit 28/20/12/4 | Bit 27/19/11/3 | Bit 26/18/10/2 | Bit 25/17/9/1 | Bit 24/16/8/0 |
|-----------|-------------------|-------------------|-------------------|-------------------|-------------------|-------------------|------------------|------------------|
| 31:24 | R-0, HS, HC | R-0, HS, HC | R-0, HS, HC | R/W-0 | R/W-0 | R/W-0 | R/W-0 | R/W-0 |
| | BGVRDY | REFFLT | EOSRDY | CVDCPL<2:0> | | | SAMC<9:8> | |
| 23:16 | R/W-0 | R/W-0 | R/W-0 | R/W-0 | R/W-0 | R/W-0 | R/W-0 | R/W-0 |
| | SAMC<7:0> | | | | | | | |
| 15:8 | R/W-0 | R/W-0 | R/W-0 | R/W-0 | U-0 | R/W-0 | R/W-0 | R/W-0 |
| | BGVRIEN | REFFLTEN | EOSIEN | ADCEIOVR | — | ADCEIS<2:0> | | |
| 7:0 | U-0 | R/W-0 | R/W-0 | R/W-0 | R/W-0 | R/W-0 | R/W-0 | R/W-0 |
| | — | ADCDIV<6:0> | | | | | | |

| | | | |
|-------------------|-------------------|------------------------------------|--------------------|
| Legend: | HC = Hardware Set | HS = Hardware Cleared | r = Reserved |
| R = Readable bit | W = Writable bit | U = Unimplemented bit, read as '0' | |
| -n = Value at POR | '1' = Bit is set | '0' = Bit is cleared | x = Bit is unknown |

- bit 31 **BGVRDY:** Band Gap Voltage/ADC Reference Voltage Status bit
 1 = Both band gap voltage and ADC reference voltages (VREF) are ready
 0 = Either or both band gap voltage and ADC reference voltages (VREF) are not ready
 Data processing is valid only after BGVRDY is set by hardware, so the application code must check that the BGVRDY bit is set to ensure data validity. This bit set to '0' when ON (ADCCON1<15>) = 0.
- bit 30 **REFFLT:** Band Gap/VREF/AVDD BOR Fault Status bit
 1 = Fault in band gap or the VREF voltage while the ON bit (ADCCON1<15>) was set. Most likely a band gap or VREF fault will be caused by a BOR of the analog VDD supply.
 0 = Band gap and VREF voltage are working properly
 This bit is cleared when the ON bit (ADCCON1<15>) = 0 and the BGVRDY bit = 1.
- bit 29 **EOSRDY:** End of Scan Interrupt Status bit
 1 = All analog inputs are considered for scanning through the scan trigger (all analog inputs specified in the ADCCSS1 and ADCCSS2 registers) have completed scanning
 0 = Scanning has not completed
 This bit is cleared when ADCCON2<31:24> are read in software.
- bit 28-26 **CVDCPL<2:0>:** Capacitor Voltage Divider (CVD) Setting bit
 111 = 7 * 2.5 pF = 17.5 pF
 110 = 6 * 2.5 pF = 15 pF
 101 = 5 * 2.5 pF = 12.5 pF
 100 = 4 * 2.5 pF = 10 pF
 011 = 3 * 2.5 pF = 7.5 pF
 010 = 2 * 2.5 pF = 5 pF
 001 = 1 * 2.5 pF = 2.5 pF
 000 = 0 * 2.5 pF = 0 pF
- bit 25-16 **SAMC<9:0>:** Sample Time for the Shared ADC (ADC7) bits
 1111111111 = 1025 TAD7
 •
 •
 •
 0000000001 = 3 TAD7
 0000000000 = 2 TAD7
 Where TAD7 = period of the ADC conversion clock for the Shared ADC (ADC7) controlled by the ADCDIV<6:0> bits.
- bit 15 **BGVRIEN:** Band Gap/VREF Voltage Ready Interrupt Enable bit
 1 = Interrupt will be generated when the BGVRDY bit is set
 0 = No interrupt is generated when the BGVRDY bit is set

PIC32MZ Embedded Connectivity with Floating Point Unit (EF) Family

REGISTER 28-2: ADCCON2: ADC CONTROL REGISTER 2 (CONTINUED)

- bit 14 **REFFLTIEN:** Band Gap/VREF Voltage Fault Interrupt Enable bit
1 = Interrupt will be generated when the REFFLT bit is set
0 = No interrupt is generated when the REFFLT bit is set
- bit 13 **EOSIEN:** End of Scan Interrupt Enable bit
1 = Interrupt will be generated when EOSRDY bit is set
0 = No interrupt is generated when the EOSRDY bit is set
- bit 12 **ADCEIOVR:** Early Interrupt Request Override bit
1 = Early interrupt generation is not overridden and interrupt generation is controlled by the ADCEIEN1 and ADCEIEN2 registers
0 = Early interrupt generation is overridden and interrupt generation is controlled by the ADCGIRQEN1 and ADCGIRQEN2 registers
- bit 11 **Unimplemented:** Read as '0'
- bit 10-8 **ADCEIS<2:0>:** Shared ADC (ADC7) Early Interrupt Select bits
These bits select the number of clocks (T_{AD7}) prior to the arrival of valid data that the associated interrupt is generated.
111 = The data ready interrupt is generated 8 ADC clocks prior to end of conversion
110 = The data ready interrupt is generated 7 ADC clocks prior to end of conversion
•
•
•
001 = The data ready interrupt is generated 2 ADC module clocks prior to end of conversion
000 = The data ready interrupt is generated 1 ADC module clock prior to end of conversion
Note: All options are available when the selected resolution, set by the SELRES<1:0> bits (ADCCON1<22:21>), is 12-bit or 10-bit. For a selected resolution of 8-bit, options from '000' to '101' are valid. For a selected resolution of 6-bit, options from '000' to '011' are valid.
- bit 7 **Unimplemented:** Read as '0'
- bit 6-0 **ADCDIV<6:0>:** Shared ADC (ADC7) Clock Divider bits
11111111 = $254 * T_Q = T_{AD7}$
•
•
•
00000111 = $6 * T_Q = T_{AD7}$
00000110 = $4 * T_Q = T_{AD7}$
00000011 = $2 * T_Q = T_{AD7}$
00000000 = Reserved
The ADCDIV<6:0> bits divide the ADC control clock (T_Q) to generate the clock for the Shared ADC, ADC7 (T_{AD7}).

PIC32MZ Embedded Connectivity with Floating Point Unit (EF) Family

REGISTER 28-3: ADCCON3: ADC CONTROL REGISTER 3

| Bit Range | Bit 31/23/15/7 | Bit 30/22/14/6 | Bit 29/21/13/5 | Bit 28/20/12/4 | Bit 27/19/11/3 | Bit 26/18/10/2 | Bit 25/17/9/1 | Bit 24/16/8/0 |
|-----------|----------------|----------------|----------------|----------------|----------------|----------------|---------------------------|---------------|
| 31:24 | R/W-0 | R/W-0 | R/W-0 | R/W-0 | R/W-0 | R/W-0 | R/W-0 | R/W-0 |
| | ADCSEL<1:0> | | CONCLKDIV<5:0> | | | | | |
| 23:16 | R/W-0 | U-0 | U-0 | R/W-0 | R/W-0 | R/W-0 | R/W-0 | R/W-0 |
| | DIGEN7 | — | — | DIGEN4 | DIGEN3 | DIGEN2 | DIGEN1 | DIGEN0 |
| 15:8 | R/W-0 | R/W-0 | R/W-0 | R/W-0 | R/W-0 | R-0, HS, HC | R/W-0 | R-0, HS, HC |
| | VREFSEL<2:0> | | | TRGSUSP | UPDIEN | UPDRDY | SAMP ^(1,2,3,4) | RQCNVRT |
| 7:0 | R/W-0 | R-0, HS, HC | R/W-0 | R/W-0 | R/W-0 | R/W-0 | R/W-0 | R/W-0 |
| | GLSWTRG | GSWTRG | ADINSEL<5:0> | | | | | |

| | | |
|-------------------|-------------------|--|
| Legend: | HC = Hardware Set | HS = Hardware Cleared |
| R = Readable bit | W = Writable bit | U = Unimplemented bit, read as '0' |
| -n = Value at POR | '1' = Bit is set | '0' = Bit is cleared x = Bit is unknown |

bit 31-30 **ADCSEL<1:0>**: Analog-to-Digital Clock Source (TCLK) bits

- 11 = FRC
- 10 = REFCLK3
- 01 = System Clock (Tcy)
- 00 = PBCLK3

bit 29-24 **CONCLKDIV<5:0>**: Analog-to-Digital Control Clock (Tq) Divider bits

- 111111 = 64 * TCLK = Tq
- .
- .
- .
- 000011 = 4 * TCLK = Tq
- 000010 = 3 * TCLK = Tq
- 000001 = 2 * TCLK = Tq
- 000000 = TCLK = Tq

bit 23 **DIGEN7**: Shared ADC (ADC7) Digital Enable bit

- 1 = ADC7 is digital enabled
- 0 = ADC7 is digital disabled

bit 22-21 **Unimplemented**: Read as '0'

bit 20 **DIGEN4**: ADC4 Digital Enable bit

- 1 = ADC4 is digital enabled
- 0 = ADC4 is digital disabled

bit 19 **DIGEN3**: ADC3 Digital Enable bit

- 1 = ADC3 is digital enabled
- 0 = ADC3 is digital disabled

Note 1: The SAMP bit has the highest priority and setting this bit will keep the S&H circuit in Sample mode until the bit is cleared. Also, usage of the SAMP bit will cause settings of SAMC<9:0> bits (ADCCON2<25:16>) to be ignored.

- 2: The SAMP bit only connects Class 2 and Class 3 analog inputs to the shared ADC, ADC7. All Class 1 analog inputs are not affected by the SAMP bit.
- 3: The SAMP bit is not a self-clearing bit and it is the responsibility of application software to first clear this bit and only after setting the RQCNVRT bit to start the analog-to-digital conversion.
- 4: Normally, when the SAMP and RQCNVRT bits are used by software routines, all TRGSRCx<4:0> bits and STRGSRC<4:0> bits should be set to '00000' to disable all external hardware triggers and prevent them from interfering with the software-controlled sampling command signal SAMP and with the software-controlled trigger RQCNVRT.

PIC32MZ Embedded Connectivity with Floating Point Unit (EF) Family

REGISTER 28-3: ADCCON3: ADC CONTROL REGISTER 3 (CONTINUED)

bit 18 **DIGEN2:** ADC2 Digital Enable bit
 1 = ADC2 is digital enabled
 0 = ADC2 is digital disabled

bit 17 **DIGEN1:** ADC1 Digital Enable bit
 1 = ADC1 is digital enabled
 0 = ADC1 is digital disabled

bit 16 **DIGEN0:** ADC0 Digital Enable bit
 1 = ADC0 is digital enabled
 0 = ADC0 is digital disabled

bit 15-13 **VREFSEL<2:0>:** Voltage Reference (VREF) Input Selection bits

| VREFSEL<2:0> | ADREF+ | ADREF- |
|--------------|----------------------|----------------|
| 1xx | Reserved; do not use | |
| 011 | External VREFH | External VREFL |
| 010 | AVDD | External VREFL |
| 001 | External VREFH | AVss |
| 000 | AVDD | AVss |

bit 12 **TRGSUSP:** Trigger Suspend bit
 1 = Triggers are blocked from starting a new analog-to-digital conversion, but the ADC module is not disabled
 0 = Triggers are not blocked

bit 11 **UPDIEN:** Update Ready Interrupt Enable bit
 1 = Interrupt will be generated when the UPDRDY bit is set by hardware
 0 = No interrupt is generated

bit 10 **UPDRDY:** ADC Update Ready Status bit
 1 = ADC SFRs can be updated
 0 = ADC SFRs cannot be updated

Note: This bit is only active while the TRGSUSP bit is set and there are no more running conversions of any ADC modules.

bit 9 **SAMP:** Class 2 and Class 3 Analog Input Sampling Enable bit^(1,2,3,4)
 1 = The ADC S&H amplifier is sampling
 0 = The ADC S&H amplifier is holding

bit 8 **RQCNVRT:** Individual ADC Input Conversion Request bit
 This bit and its associated ADINSEL<5:0> bits enable the user to individually request an analog-to-digital conversion of an analog input through software.
 1 = Trigger the conversion of the selected ADC input as specified by the ADINSEL<5:0> bits
 0 = Do not trigger the conversion

Note: This bit is automatically cleared in the next ADC clock cycle.

bit 7 **GLSWTRG:** Global Level Software Trigger bit
 1 = Trigger conversion for ADC inputs that have selected the GLSWTRG bit as the trigger signal, either through the associated TRGSRC<4:0> bits in the ADCTRGx registers or through the STRGSRC<4:0> bits in the ADCCON1 register
 0 = Do not trigger an analog-to-digital conversion

Note 1: The SAMP bit has the highest priority and setting this bit will keep the S&H circuit in Sample mode until the bit is cleared. Also, usage of the SAMP bit will cause settings of SAMC<9:0> bits (ADCCON2<25:16>) to be ignored.

2: The SAMP bit only connects Class 2 and Class 3 analog inputs to the shared ADC, ADC7. All Class 1 analog inputs are not affected by the SAMP bit.

3: The SAMP bit is not a self-clearing bit and it is the responsibility of application software to first clear this bit and only after setting the RQCNVRT bit to start the analog-to-digital conversion.

4: Normally, when the SAMP and RQCNVRT bits are used by software routines, all TRGSRCx<4:0> bits and STRGSRC<4:0> bits should be set to '00000' to disable all external hardware triggers and prevent them from interfering with the software-controlled sampling command signal SAMP and with the software-controlled trigger RQCNVRT.

PIC32MZ Embedded Connectivity with Floating Point Unit (EF) Family

REGISTER 28-3: ADCCON3: ADC CONTROL REGISTER 3 (CONTINUED)

bit 6 **GSWTRG**: Global Software Trigger bit

1 = Trigger conversion for ADC inputs that have selected the GSWTRG bit as the trigger signal, either through the associated TRGSRC<4:0> bits in the ADCTR_x registers or through the STRGSRC<4:0> bits in the ADCCON1 register

0 = Do not trigger an analog-to-digital conversion

Note: This bit is automatically cleared in the next ADC clock cycle.

bit 5-0 **ADINSEL<5:0>**: Analog Input Select bits

These bits select the analog input to be converted when the RQCNVRT bit is set. As a general rule:

111111 = Reserved

•
•
•

101101 = Reserved

101100 = MAX_AN_INPUT + 2 = IVTEMP

101011 = MAX_AN_INPUT + 1 = IVREF

101010 = MAX_AN_INPUT = AN[MAX_AN_INPUT]

•
•
•

000001 = AN1

000000 = AN0

- Note 1:** The SAMP bit has the highest priority and setting this bit will keep the S&H circuit in Sample mode until the bit is cleared. Also, usage of the SAMP bit will cause settings of SAMC<9:0> bits (ADCCON2<25:16>) to be ignored.
- 2: The SAMP bit only connects Class 2 and Class 3 analog inputs to the shared ADC, ADC7. All Class 1 analog inputs are not affected by the SAMP bit.
 - 3: The SAMP bit is not a self-clearing bit and it is the responsibility of application software to first clear this bit and only after setting the RQCNVRT bit to start the analog-to-digital conversion.
 - 4: Normally, when the SAMP and RQCNVRT bits are used by software routines, all TRGSRC_x<4:0> bits and STRGSRC<4:0> bits should be set to '00000' to disable all external hardware triggers and prevent them from interfering with the software-controlled sampling command signal SAMP and with the software-controlled trigger RQCNVRT.

PIC32MZ Embedded Connectivity with Floating Point Unit (EF) Family

REGISTER 28-4: ADCTRGMODE: ADC TRIGGERING MODE FOR DEDICATED ADC REGISTER

| Bit Range | Bit 31/23/15/7 | Bit 30/22/14/6 | Bit 29/21/13/5 | Bit 28/20/12/4 | Bit 27/19/11/3 | Bit 26/18/10/2 | Bit 25/17/9/1 | Bit 24/16/8/0 |
|-----------|----------------|----------------|----------------|----------------|----------------|----------------|---------------|---------------|
| 31:24 | U-0 | U-0 | U-0 | U-0 | U-0 | U-0 | R/W-0 | R/W-0 |
| | — | — | — | — | — | — | SH4ALT<1:0> | |
| 23:16 | R/W-0 | R/W-0 | R/W-0 | R/W-0 | R/W-0 | R/W-0 | R/W-0 | R/W-0 |
| | SH3ALT<1:0> | | SH2ALT<1:0> | | SH1ALT<1:0> | | SH0ALT<1:0> | |
| 15:8 | U-0 | U-0 | U-0 | R/W-0 | R/W-0 | R/W-0 | R/W-0 | R/W-0 |
| | — | — | — | STRGEN4 | STRGEN3 | STRGEN2 | STRGEN1 | STRGEN0 |
| 7:0 | U-0 | U-0 | U-0 | R/W-0 | R/W-0 | R/W-0 | R/W-0 | R/W-0 |
| | — | — | — | SSAMPEN4 | SSAMPEN3 | SSAMPEN2 | SSAMPEN1 | SSAMPEN0 |

Legend:

R = Readable bit W = Writable bit U = Unimplemented bit, read as '0'
 -n = Value at POR '1' = Bit is set '0' = Bit is cleared x = Bit is unknown

bit 31-26 **Unimplemented:** Read as '0'

bit 25-24 **SH4ALT<1:0>**: ADC4 Analog Input Select bit

- 11 = Reserved
- 10 = Reserved
- 01 = AN49
- 00 = AN4

bit 23-22 **SH3ALT<1:0>**: ADC3 Analog Input Select bit

- 11 = Reserved
- 10 = Reserved
- 01 = AN48
- 00 = AN3

bit 21-20 **SH2ALT<1:0>**: ADC2 Analog Input Select bit

- 11 = Reserved
- 10 = Reserved
- 01 = AN47
- 00 = AN2

bit 19-18 **SH1ALT<1:0>**: ADC1 Analog Input Select bit

- 11 = Reserved
- 10 = Reserved
- 01 = AN46
- 00 = AN1

bit 17-16 **SH0ALT<1:0>**: ADC0 Analog Input Select bit

- 11 = Reserved
- 10 = Reserved
- 01 = AN45
- 00 = AN0

bit 15-13 **Unimplemented:** Read as '0'

bit 12 **STRGEN4**: ADC4 Presynchronized Triggers bit

- 1 = ADC4 uses presynchronized triggers
- 0 = ADC4 does not use presynchronized triggers

bit 11 **STRGEN3**: ADC3 Presynchronized Triggers bit

- 1 = ADC3 uses presynchronized triggers
- 0 = ADC3 does not use presynchronized triggers

bit 10 **STRGEN2**: ADC2 Presynchronized Triggers bit

- 1 = ADC2 uses presynchronized triggers
- 0 = ADC2 does not use presynchronized triggers

PIC32MZ Embedded Connectivity with Floating Point Unit (EF) Family

REGISTER 28-4: ADCTRGMODE: ADC TRIGGERING MODE FOR DEDICATED ADC REGISTER

- bit 9 **STRGEN1:** ADC1 Presynchronized Triggers bit
 1 = ADC1 uses presynchronized triggers
 0 = ADC1 does not use presynchronized triggers
- bit 8 **STRGEN0:** ADC0 Presynchronized Triggers bit
 1 = ADC0 uses presynchronized triggers
 0 = ADC0 does not use presynchronized triggers
- bit 7-5 **Unimplemented:** Read as '0'
- bit 4 **SSAMPEN4:** ADC4 Synchronous Sampling bit
 1 = ADC4 uses synchronous sampling for the first sample after being idle or disabled
 0 = ADC4 does not use synchronous sampling
- bit 3 **SSAMPEN3:** ADC3 Synchronous Sampling bit
 1 = ADC3 uses synchronous sampling for the first sample after being idle or disabled
 0 = ADC3 does not use synchronous sampling
- bit 2 **SSAMPEN2:** ADC2 Synchronous Sampling bit
 1 = ADC2 uses synchronous sampling for the first sample after being idle or disabled
 0 = ADC2 does not use synchronous sampling
- bit 1 **SSAMPEN1:** ADC1 Synchronous Sampling bit
 1 = ADC1 uses synchronous sampling for the first sample after being idle or disabled
 0 = ADC1 does not use synchronous sampling
- bit 0 **SSAMPEN0:** ADC0 Synchronous Sampling bit
 1 = ADC0 uses synchronous sampling for the first sample after being idle or disabled
 0 = ADC0 does not use synchronous sampling

PIC32MZ Embedded Connectivity with Floating Point Unit (EF) Family

REGISTER 28-5: ADCIMCON1: ADC INPUT MODE CONTROL REGISTER 1

| Bit Range | Bit 31/23/15/7 | Bit 30/22/14/6 | Bit 29/21/13/5 | Bit 28/20/12/4 | Bit 27/19/11/3 | Bit 26/18/10/2 | Bit 25/17/9/1 | Bit 24/16/8/0 |
|-----------|-------------------|-------------------|-------------------|-------------------|-------------------|-------------------|------------------|------------------|
| 31:24 | R/W-0 | R/W-0 | R/W-0 | R/W-0 | R/W-0 | R/W-0 | R/W-0 | R/W-0 |
| | DIFF15 | SIGN15 | DIFF14 | SIGN14 | DIFF13 | SIGN13 | DIFF12 | SIGN12 |
| 23:16 | R/W-0 | R/W-0 | R/W-0 | R/W-0 | R/W-0 | R/W-0 | R/W-0 | R/W-0 |
| | DIFF11 | SIGN11 | DIFF10 | SIGN10 | DIFF9 | SIGN9 | DIFF8 | SIGN8 |
| 15:8 | R/W-0 | R/W-0 | R/W-0 | R/W-0 | R/W-0 | R/W-0 | R/W-0 | R/W-0 |
| | DIFF7 | SIGN7 | DIFF6 | SIGN6 | DIFF5 | SIGN5 | DIFF4 | SIGN4 |
| 7:0 | R/W-0 | R/W-0 | R/W-0 | R/W-0 | R/W-0 | R/W-0 | R/W-0 | R/W-0 |
| | DIFF3 | SIGN3 | DIFF2 | SIGN2 | DIFF1 | SIGN1 | DIFF0 | SIGN0 |

Legend:

R = Readable bit W = Writable bit U = Unimplemented bit, read as '0'
 -n = Value at POR '1' = Bit is set '0' = Bit is cleared x = Bit is unknown

- bit 31 **DIFF15:** AN15 Mode bit
 1 = AN15 is using Differential mode
 0 = AN15 is using Single-ended mode
- bit 30 **SIGN:15** AN15 Signed Data Mode bit
 1 = AN15 is using Signed Data mode
 0 = AN15 is using Unsigned Data mode
- bit 29 **DIFF14:** AN14 Mode bit
 1 = AN14 is using Differential mode
 0 = AN14 is using Single-ended mode
- bit 28 **SIGN14:** AN14 Signed Data Mode bit
 1 = AN14 is using Signed Data mode
 0 = AN14 is using Unsigned Data mode
- bit 27 **DIFF13:** AN13 Mode bit
 1 = AN13 is using Differential mode
 0 = AN13 is using Single-ended mode
- bit 26 **SIGN13:** AN13 Signed Data Mode bit
 1 = AN13 is using Signed Data mode
 0 = AN13 is using Unsigned Data mode
- bit 25 **DIFF12:** AN12 Mode bit
 1 = AN12 is using Differential mode
 0 = AN12 is using Single-ended mode
- bit 24 **SIGN12:** AN12 Signed Data Mode bit
 1 = AN12 is using Signed Data mode
 0 = AN12 is using Unsigned Data mode
- bit 23 **DIFF11:** AN11 Mode bit
 1 = AN11 is using Differential mode
 0 = AN11 is using Single-ended mode
- bit 22 **SIGN11:** AN11 Signed Data Mode bit
 1 = AN11 is using Signed Data mode
 0 = AN11 is using Unsigned Data mode
- bit 21 **DIFF10:** AN10 Mode bit
 1 = AN10 is using Differential mode
 0 = AN10 is using Single-ended mode

PIC32MZ Embedded Connectivity with Floating Point Unit (EF) Family

REGISTER 28-5: ADCIMCON1: ADC INPUT MODE CONTROL REGISTER 1 (CONTINUED)

| | |
|--------|--|
| bit 20 | SIGN10: AN10 Signed Data Mode bit 1 = AN10 is using Signed Data mode 0 = AN10 is using Unsigned Data mode |
| bit 19 | DIFF9: AN9 Mode bit 1 = AN9 is using Differential mode 0 = AN9 is using Single-ended mode |
| bit 18 | SIGN9: AN9 Signed Data Mode bit 1 = AN9 is using Signed Data mode 0 = AN9 is using Unsigned Data mode |
| bit 17 | DIFF8: AN 8 Mode bit 1 = AN8 is using Differential mode 0 = AN8 is using Single-ended mode |
| bit 16 | SIGN8: AN8 Signed Data Mode bit 1 = AN8 is using Signed Data mode 0 = AN8 is using Unsigned Data mode |
| bit 15 | DIFF7: AN7 Mode bit 1 = AN7 is using Differential mode 0 = AN7 is using Single-ended mode |
| bit 14 | SIGN7: AN7 Signed Data Mode bit 1 = AN7 is using Signed Data mode 0 = AN7 is using Unsigned Data mode |
| bit 13 | DIFF6: AN6 Mode bit 1 = AN6 is using Differential mode 0 = AN6 is using Single-ended mode |
| bit 12 | SIGN6: AN6 Signed Data Mode bit 1 = AN6 is using Signed Data mode 0 = AN6 is using Unsigned Data mode |
| bit 11 | DIFF5: AN5 Mode bit 1 = AN5 is using Differential mode 0 = AN5 is using Single-ended mode |
| bit 10 | SIGN5: AN5 Signed Data Mode bit 1 = AN5 is using Signed Data mode 0 = AN5 is using Unsigned Data mode |
| bit 9 | DIFF4: AN4 Mode bit 1 = AN4 is using Differential mode 0 = AN4 is using Single-ended mode |
| bit 8 | SIGN4: AN4 Signed Data Mode bit 1 = AN4 is using Signed Data mode 0 = AN4 is using Unsigned Data mode |
| bit 7 | DIFF3: AN3 Mode bit 1 = AN3 is using Differential mode 0 = AN3 is using Single-ended mode |
| bit 6 | SIGN3: AN3 Signed Data Mode bit 1 = AN3 is using Signed Data mode 0 = AN3 is using Unsigned Data mode |
| bit 5 | DIFF2: AN2 Mode bit 1 = AN2 is using Differential mode 0 = AN2 is using Single-ended mode |

PIC32MZ Embedded Connectivity with Floating Point Unit (EF) Family

REGISTER 28-5: ADCIMCON1: ADC INPUT MODE CONTROL REGISTER 1 (CONTINUED)

- bit 4 **SIGN2:** AN2 Signed Data Mode bit
 1 = AN2 is using Signed Data mode
 0 = AN2 is using Unsigned Data mode
- bit 3 **DIFF1:** AN1 Mode bit
 1 = AN1 is using Differential mode
 0 = AN1 is using Single-ended mode
- bit 2 **SIGN1:** AN1 Signed Data Mode bit
 1 = AN1 is using Signed Data mode
 0 = AN1 is using Unsigned Data mode
- bit 1 **DIFF0:** AN0 Mode bit
 1 = AN0 is using Differential mode
 0 = AN0 is using Single-ended mode
- bit 0 **SIGN0:** AN0 Signed Data Mode bit
 1 = AN0 is using Signed Data mode
 0 = AN0 is using Unsigned Data mode

PIC32MZ Embedded Connectivity with Floating Point Unit (EF) Family

REGISTER 28-6: ADCIMCON2: ADC INPUT MODE CONTROL REGISTER 2

| Bit Range | Bit 31/23/15/7 | Bit 30/22/14/6 | Bit 29/21/13/5 | Bit 28/20/12/4 | Bit 27/19/11/3 | Bit 26/18/10/2 | Bit 25/17/9/1 | Bit 24/16/8/0 |
|-----------|-----------------------|-----------------------|-----------------------|-----------------------|-----------------------|-----------------------|-----------------------|-----------------------|
| 31:24 | R/W-0 | R/W-0 | R/W-0 | R/W-0 | R/W-0 | R/W-0 | R/W-0 | R/W-0 |
| | DIFF31 ⁽¹⁾ | SIGN31 ⁽¹⁾ | DIFF30 ⁽¹⁾ | SIGN30 ⁽¹⁾ | DIFF29 ⁽¹⁾ | SIGN29 ⁽¹⁾ | DIFF28 ⁽¹⁾ | SIGN28 ⁽¹⁾ |
| 23:16 | R/W-0 | R/W-0 | R/W-0 | R/W-0 | R/W-0 | R/W-0 | R/W-0 | R/W-0 |
| | DIFF27 ⁽¹⁾ | SIGN27 ⁽¹⁾ | DIFF26 ⁽¹⁾ | SIGN26 ⁽¹⁾ | DIFF25 ⁽¹⁾ | SIGN25 ⁽¹⁾ | DIFF24 ⁽¹⁾ | SIGN24 ⁽¹⁾ |
| 15:8 | R/W-0 | R/W-0 | R/W-0 | R/W-0 | R/W-0 | R/W-0 | R/W-0 | R/W-0 |
| | DIFF23 ⁽¹⁾ | SIGN23 ⁽¹⁾ | DIFF22 ⁽¹⁾ | SIGN22 ⁽¹⁾ | DIFF21 ⁽¹⁾ | SIGN21 ⁽¹⁾ | DIFF20 ⁽¹⁾ | SIGN20 ⁽¹⁾ |
| 7:0 | R/W-0 | R/W-0 | R/W-0 | R/W-0 | R/W-0 | R/W-0 | R/W-0 | R/W-0 |
| | DIFF19 ⁽¹⁾ | SIGN19 ⁽¹⁾ | DIFF18 | SIGN18 | DIFF17 | SIGN17 | DIFF16 | SIGN16 |

Legend:

R = Readable bit W = Writable bit U = Unimplemented bit, read as '0'
-n = Value at POR '1' = Bit is set '0' = Bit is cleared x = Bit is unknown

- bit 31 **DIFF31:** AN31 Mode bit⁽¹⁾
1 = AN31 is using Differential mode
0 = AN31 is using Single-ended mode
- bit 30 **SIGN31:** AN31 Signed Data Mode bit⁽¹⁾
1 = AN31 is using Signed Data mode
0 = AN31 is using Unsigned Data mode
- bit 29 **DIFF30:** AN30 Mode bit⁽¹⁾
1 = AN30 is using Differential mode
0 = AN30 is using Single-ended mode
- bit 28 **SIGN30:** AN30 Signed Data Mode bit⁽¹⁾
1 = AN30 is using Signed Data mode
0 = AN30 is using Unsigned Data mode
- bit 27 **DIFF29:** AN29 Mode bit⁽¹⁾
1 = AN29 is using Differential mode
0 = AN29 is using Single-ended mode
- bit 26 **SIGN29:** AN29 Signed Data Mode bit⁽¹⁾
1 = AN29 is using Signed Data mode
0 = AN29 is using Unsigned Data mode
- bit 25 **DIFF28:** AN28 Mode bit⁽¹⁾
1 = AN28 is using Differential mode
0 = AN28 is using Single-ended mode
- bit 24 **SIGN28:** AN28 Signed Data Mode bit⁽¹⁾
1 = AN28 is using Signed Data mode
0 = AN28 is using Unsigned Data mode
- bit 23 **DIFF27:** AN27 Mode bit⁽¹⁾
1 = AN27 is using Differential mode
0 = AN27 is using Single-ended mode
- bit 22 **SIGN27:** AN27 Signed Data Mode bit⁽¹⁾
1 = AN27 is using Signed Data mode
0 = AN27 is using Unsigned Data mode

Note 1: This bit is not available on 64-pin devices.

PIC32MZ Embedded Connectivity with Floating Point Unit (EF) Family

REGISTER 28-6: ADCIMCON2: ADC INPUT MODE CONTROL REGISTER 2 (CONTINUED)

| | |
|--------|---|
| bit 21 | DIFF26: AN26 Mode bit ⁽¹⁾ 1 = AN26 is using Differential mode 0 = AN26 is using Single-ended mode |
| bit 20 | SIGN26: AN26 Signed Data Mode bit ⁽¹⁾ 1 = AN26 is using Signed Data mode 0 = AN26 is using Unsigned Data mode |
| bit 19 | DIFF25: AN25 Mode bit ⁽¹⁾ 1 = AN25 is using Differential mode 0 = AN25 is using Single-ended mode |
| bit 18 | SIGN25: AN25 Signed Data Mode bit ⁽¹⁾ 1 = AN25 is using Signed Data mode 0 = AN25 is using Unsigned Data mode |
| bit 17 | DIFF24: AN24 Mode bit ⁽¹⁾ 1 = AN24 is using Differential mode 0 = AN24 is using Single-ended mode |
| bit 16 | SIGN24: AN24 Signed Data Mode bit ⁽¹⁾ 1 = AN24 is using Signed Data mode 0 = AN24 is using Unsigned Data mode |
| bit 15 | DIFF23: AN23 Mode bit ⁽¹⁾ 1 = AN23 is using Differential mode 0 = AN23 is using Single-ended mode |
| bit 14 | SIGN23: AN23 Signed Data Mode bit ⁽¹⁾ 1 = AN23 is using Signed Data mode 0 = AN23 is using Unsigned Data mode |
| bit 13 | DIFF22: AN22 Mode bit ⁽¹⁾ 1 = AN22 is using Differential mode 0 = AN22 is using Single-ended mode |
| bit 12 | SIGN22: AN22 Signed Data Mode bit ⁽¹⁾ 1 = AN22 is using Signed Data mode 0 = AN22 is using Unsigned Data mode |
| bit 11 | DIFF21: AN21 Mode bit ⁽¹⁾ 1 = AN21 is using Differential mode 0 = AN21 is using Single-ended mode |
| bit 10 | SIGN21: AN21 Signed Data Mode bit ⁽¹⁾ 1 = AN21 is using Signed Data mode 0 = AN21 is using Unsigned Data mode |
| bit 9 | DIFF20: AN20 Mode bit ⁽¹⁾ 1 = AN20 is using Differential mode 0 = AN20 is using Single-ended mode |
| bit 8 | SIGN20: AN20 Signed Data Mode bit ⁽¹⁾ 1 = AN20 is using Signed Data mode 0 = AN20 is using Unsigned Data mode |
| bit 7 | DIFF19: AN19 Mode bit ⁽¹⁾ 1 = AN19 is using Differential mode 0 = AN19 is using Single-ended mode |

Note 1: This bit is not available on 64-pin devices.

PIC32MZ Embedded Connectivity with Floating Point Unit (EF) Family

REGISTER 28-6: ADCIMCON2: ADC INPUT MODE CONTROL REGISTER 2 (CONTINUED)

| | |
|-------|---|
| bit 6 | SIGN19: AN19 Signed Data Mode bit ⁽¹⁾ 1 = AN19 is using Signed Data mode 0 = AN19 is using Unsigned Data mode |
| bit 5 | DIFF18: AN18 Mode bit 1 = AN18 is using Differential mode 0 = AN18 is using Single-ended mode |
| bit 4 | SIGN18: AN18 Signed Data Mode bit 1 = AN18 is using Signed Data mode 0 = AN18 is using Unsigned Data mode |
| bit 3 | DIFF17: AN17 Mode bit 1 = AN17 is using Differential mode 0 = AN17 is using Single-ended mode |
| bit 2 | SIGN17: AN17 Signed Data Mode bit 1 = AN17 is using Signed Data mode 0 = AN17 is using Unsigned Data mode |
| bit 1 | DIFF16: AN16 Mode bit 1 = AN16 is using Differential mode 0 = AN16 is using Single-ended mode |
| bit 0 | SIGN16: AN16 Signed Data Mode bit 1 = AN16 is using Signed Data mode 0 = AN16 is using Unsigned Data mode |

Note 1: This bit is not available on 64-pin devices.

PIC32MZ Embedded Connectivity with Floating Point Unit (EF) Family

REGISTER 28-7: ADCIMCON3: ADC INPUT MODE CONTROL REGISTER 3

| Bit Range | Bit 31/23/15/7 | Bit 30/22/14/6 | Bit 29/21/13/5 | Bit 28/20/12/4 | Bit 27/19/11/3 | Bit 26/18/10/2 | Bit 25/17/9/1 | Bit 24/16/8/0 |
|-----------|-----------------------|-----------------------|-----------------------|-----------------------|-----------------------|-----------------------|-----------------------|-----------------------|
| 31:24 | U-0 | U-0 | U-0 | U-0 | U-0 | U-0 | R/W-0 | R/W-0 |
| | — | — | — | — | — | — | DIFF44 | SIGN44 |
| 23:16 | R/W-0 | R/W-0 | R/W-0 | R/W-0 | R/W-0 | R/W-0 | R/W-0 | R/W-0 |
| | DIFF43 | SIGN43 | DIFF42 ⁽²⁾ | SIGN42 ⁽²⁾ | DIFF41 ⁽²⁾ | SIGN41 ⁽²⁾ | DIFF40 ⁽²⁾ | SIGN40 ⁽²⁾ |
| 15:8 | R/W-0 | R/W-0 | R/W-0 | R/W-0 | R/W-0 | R/W-0 | R/W-0 | R/W-0 |
| | DIFF39 ⁽²⁾ | SIGN39 ⁽²⁾ | DIFF38 ⁽²⁾ | SIGN38 ⁽²⁾ | DIFF37 ⁽²⁾ | SIGN37 ⁽²⁾ | DIFF36 ⁽²⁾ | SIGN36 ⁽²⁾ |
| 7:0 | R/W-0 | R/W-0 | R/W-0 | R/W-0 | R/W-0 | R/W-0 | R/W-0 | R/W-0 |
| | DIFF35 ⁽²⁾ | SIGN35 ⁽²⁾ | DIFF34 ⁽¹⁾ | SIGN34 ⁽¹⁾ | DIFF33 ⁽¹⁾ | SIGN33 ⁽¹⁾ | DIFF32 ⁽¹⁾ | SIGN32 ⁽¹⁾ |

Legend:

R = Readable bit W = Writable bit U = Unimplemented bit, read as '0'
 -n = Value at POR '1' = Bit is set '0' = Bit is cleared x = Bit is unknown

- bit 31-26 **Unimplemented:** Read as '0'
- bit 25 **DIFF44:** AN44 Mode bit
 1 = AN44 is using Differential mode
 0 = AN44 is using Single-ended mode
- bit 24 **SIGN44:** AN44 Signed Data Mode bit
 1 = AN44 is using Signed Data mode
 0 = AN44 is using Unsigned Data mode
- bit 23 **DIFF43:** AN43 Mode bit
 1 = AN43 is using Differential mode
 0 = AN43 is using Single-ended mode
- bit 22 **SIGN43:** AN43 Signed Data Mode bit
 1 = AN43 is using Signed Data mode
 0 = AN43 is using Unsigned Data mode
- bit 21 **DIFF42:** AN42 Mode bit⁽²⁾
 1 = AN42 is using Differential mode
 0 = AN42 is using Single-ended mode
- bit 20 **SIGN42:** AN42 Signed Data Mode bit⁽²⁾
 1 = AN42 is using Signed Data mode
 0 = AN42 is using Unsigned Data mode
- bit 19 **DIFF41:** AN41 Mode bit⁽²⁾
 1 = AN41 is using Differential mode
 0 = AN41 is using Single-ended mode
- bit 18 **SIGN41:** AN41 Signed Data Mode bit⁽²⁾
 1 = AN41 is using Signed Data mode
 0 = AN41 is using Unsigned Data mode
- bit 17 **DIFF40:** AN40 Mode bit⁽²⁾
 1 = AN40 is using Differential mode
 0 = AN40 is using Single-ended mode

Note 1: This bit is not available on 64-pin devices.
Note 2: This bit is not available on 64-pin and 100-pin devices.

PIC32MZ Embedded Connectivity with Floating Point Unit (EF) Family

REGISTER 28-7: ADCIMCON3: ADC INPUT MODE CONTROL REGISTER 3 (CONTINUED)

| | |
|--------|---|
| bit 16 | SIGN40: AN40 Signed Data Mode bit ⁽²⁾ 1 = AN40 is using Signed Data mode 0 = AN40 is using Unsigned Data mode |
| bit 15 | DIFF39: AN39 Mode bit ⁽²⁾ 1 = AN39 is using Differential mode 0 = AN39 is using Single-ended mode |
| bit 14 | SIGN39: AN39 Signed Data Mode bit ⁽²⁾ 1 = AN39 is using Signed Data mode 0 = AN39 is using Unsigned Data mode |
| bit 13 | DIFF38: AN38 Mode bit ⁽²⁾ 1 = AN38 is using Differential mode 0 = AN38 is using Single-ended mode |
| bit 12 | SIGN38: AN38 Signed Data Mode bit ⁽²⁾ 1 = AN38 is using Signed Data mode 0 = AN38 is using Unsigned Data mode |
| bit 11 | DIFF37: AN37 Mode bit ⁽²⁾ 1 = AN37 is using Differential mode 0 = AN37 is using Single-ended mode |
| bit 10 | SIGN37: AN37 Signed Data Mode bit ⁽²⁾ 1 = AN37 is using Signed Data mode 0 = AN37 is using Unsigned Data mode |
| bit 9 | DIFF36: AN36 Mode bit ⁽²⁾ 1 = AN36 is using Differential mode 0 = AN36 is using Single-ended mode |
| bit 8 | SIGN36: AN36 Signed Data Mode bit ⁽²⁾ 1 = AN36 is using Signed Data mode 0 = AN36 is using Unsigned Data mode |
| bit 7 | DIFF35: AN35 Mode bit ⁽²⁾ 1 = AN35 is using Differential mode 0 = AN35 is using Single-ended mode |
| bit 6 | SIGN35: AN35 Signed Data Mode bit ⁽²⁾ 1 = AN35 is using Signed Data mode 0 = AN35 is using Unsigned Data mode |
| bit 5 | DIFF34: AN34 Mode bit ⁽¹⁾ 1 = AN34 is using Differential mode 0 = AN34 is using Single-ended mode |
| bit 4 | SIGN34: AN34 Signed Data Mode bit ⁽¹⁾ 1 = AN34 is using Signed Data mode 0 = AN34 is using Unsigned Data mode |
| bit 3 | DIFF33: AN33 Mode bit ⁽¹⁾ 1 = AN33 is using Differential mode 0 = AN33 is using Single-ended mode |
| bit 2 | SIGN33: AN33 Signed Data Mode bit ⁽¹⁾ 1 = AN33 is using Signed Data mode 0 = AN33 is using Unsigned Data mode |

Note 1: This bit is not available on 64-pin devices.

2: This bit is not available on 64-pin and 100-pin devices.

PIC32MZ Embedded Connectivity with Floating Point Unit (EF) Family

REGISTER 28-7: ADCIMCON3: ADC INPUT MODE CONTROL REGISTER 3 (CONTINUED)

- bit 1 **DIFF32:** AN32 Mode bit⁽¹⁾
 1 = AN32 is using Differential mode
 0 = AN32 is using Single-ended mode
- bit 0 **SIGN32:** AN32 Signed Data Mode bit⁽¹⁾
 1 = AN32 is using Signed Data mode
 0 = AN32 is using Unsigned Data mode

- Note 1:** This bit is not available on 64-pin devices.
Note 2: This bit is not available on 64-pin and 100-pin devices.

PIC32MZ Embedded Connectivity with Floating Point Unit (EF) Family

REGISTER 28-8: ADCGIRQEN1: ADC GLOBAL INTERRUPT ENABLE REGISTER 1

| Bit Range | Bit 31/23/15/7 | Bit 30/22/14/6 | Bit 29/21/13/5 | Bit 28/20/12/4 | Bit 27/19/11/3 | Bit 26/18/10/2 | Bit 25/17/9/1 | Bit 24/16/8/0 |
|-----------|------------------------|------------------------|------------------------|------------------------|------------------------|------------------------|------------------------|------------------------|
| 31:24 | R/W-0 | R/W-0 | R/W-0 | R/W-0 | R/W-0 | R/W-0 | R/W-0 | R/W-0 |
| | AGIEN31 ⁽¹⁾ | AGIEN30 ⁽¹⁾ | AGIEN29 ⁽¹⁾ | AGIEN28 ⁽¹⁾ | AGIEN27 ⁽¹⁾ | AGIEN26 ⁽¹⁾ | AGIEN25 ⁽¹⁾ | AGIEN24 ⁽¹⁾ |
| 23:16 | R/W-0 | R/W-0 | R/W-0 | R/W-0 | R/W-0 | R/W-0 | R/W-0 | R/W-0 |
| | AGIEN23 ⁽¹⁾ | AGIEN22 ⁽¹⁾ | AGIEN21 ⁽¹⁾ | AGIEN20 ⁽¹⁾ | AGIEN19 ⁽¹⁾ | AGIEN18 | AGIEN17 | AGIEN16 |
| 15:8 | R/W-0 | R/W-0 | R/W-0 | R/W-0 | R/W-0 | R/W-0 | R/W-0 | R/W-0 |
| | AGIEN15 | AGIEN14 | AGIEN13 | AGIEN12 | AGIEN11 | AGIEN10 | AGIEN9 | AGIEN8 |
| 7:0 | R/W-0 | R/W-0 | R/W-0 | R/W-0 | R/W-0 | R/W-0 | R/W-0 | R/W-0 |
| | AGIEN7 | AGIEN6 | AGIEN5 | AGIEN4 | AGIEN3 | AGIEN2 | AGIEN1 | AGIEN0 |

Legend:

R = Readable bit W = Writable bit U = Unimplemented bit, read as '0'
-n = Value at POR '1' = Bit is set '0' = Bit is cleared x = Bit is unknown

bit 31-0 **AGIEN31:AGIEN0**: ADC Global Interrupt Enable bits

- 1 = Interrupts are enabled for the selected analog input. The interrupt is generated after the converted data is ready (indicated by the ARDY_x bit ('x' = 31-0) of the ADCDSTAT1 register)
- 0 = Interrupts are disabled

Note 1: This bit is not available on 64-pin devices.

REGISTER 28-9: ADCGIRQEN2: ADC GLOBAL INTERRUPT ENABLE REGISTER 2

| Bit Range | Bit 31/23/15/7 | Bit 30/22/14/6 | Bit 29/21/13/5 | Bit 28/20/12/4 | Bit 27/19/11/3 | Bit 26/18/10/2 | Bit 25/17/9/1 | Bit 24/16/8/0 |
|-----------|------------------------|------------------------|------------------------|------------------------|------------------------|------------------------|------------------------|------------------------|
| 31:24 | U-0 | U-0 | U-0 | U-0 | U-0 | U-0 | U-0 | U-0 |
| | — | — | — | — | — | — | — | — |
| 23:16 | U-0 | U-0 | U-0 | U-0 | U-0 | U-0 | U-0 | U-0 |
| | — | — | — | — | — | — | — | — |
| 15:8 | U-0 | U-0 | U-0 | R/W-0 | R/W-0 | R/W-0 | R/W-0 | R/W-0 |
| | — | — | — | AGIEN44 ⁽²⁾ | AGIEN43 ⁽²⁾ | AGIEN42 ⁽²⁾ | AGIEN41 ⁽²⁾ | AGIEN40 ⁽²⁾ |
| 7:0 | R/W-0 | R/W-0 | R/W-0 | R/W-0 | R/W-0 | R/W-0 | R/W-0 | R/W-0 |
| | AGIEN39 ⁽²⁾ | AGIEN38 ⁽²⁾ | AGIEN37 ⁽²⁾ | AGIEN36 ⁽²⁾ | AGIEN35 ⁽²⁾ | AGIEN34 ⁽¹⁾ | AGIEN33 ⁽¹⁾ | AGIEN32 ⁽¹⁾ |

Legend:

R = Readable bit W = Writable bit U = Unimplemented bit, read as '0'
-n = Value at POR '1' = Bit is set '0' = Bit is cleared x = Bit is unknown

bit 31-13 **Unimplemented:** Read as '0'

bit 12-0 **AGIEN44:AGIEN32** ADC Global Interrupt Enable bits

- 1 = Interrupts are enabled for the selected analog input. The interrupt is generated after the converted data is ready (indicated by the ARDY_x bit ('x' = 44-32) of the ADCDSTAT2 register)
- 0 = Interrupts are disabled

Note 1: This bit is not available on 64-pin devices.

2: This bit is not available on 64-pin and 100-pin devices.

PIC32MZ Embedded Connectivity with Floating Point Unit (EF) Family

REGISTER 28-10: ADCCSS1: ADC COMMON SCAN SELECT REGISTER 1

| Bit Range | Bit 31/23/15/7 | Bit 30/22/14/6 | Bit 29/21/13/5 | Bit 28/20/12/4 | Bit 27/19/11/3 | Bit 26/18/10/2 | Bit 25/17/9/1 | Bit 24/16/8/0 |
|-----------|----------------------|----------------------|----------------------|----------------------|----------------------|----------------------|----------------------|----------------------|
| 31:24 | R/W-0 | R/W-0 | R/W-0 | R/W-0 | R/W-0 | R/W-0 | R/W-0 | R/W-0 |
| | CSS31 ⁽¹⁾ | CSS30 ⁽¹⁾ | CSS29 ⁽¹⁾ | CSS28 ⁽¹⁾ | CSS27 ⁽¹⁾ | CSS26 ⁽¹⁾ | CSS25 ⁽¹⁾ | CSS24 ⁽¹⁾ |
| 23:16 | R/W-0 | R/W-0 | R/W-0 | R/W-0 | R/W-0 | R/W-0 | R/W-0 | R/W-0 |
| | CSS23 ⁽¹⁾ | CSS22 ⁽¹⁾ | CSS21 ⁽¹⁾ | CSS20 ⁽¹⁾ | CSS19 ⁽¹⁾ | CSS18 | CSS17 | CSS16 |
| 15:8 | R/W-0 | R/W-0 | R/W-0 | R/W-0 | R/W-0 | R/W-0 | R/W-0 | R/W-0 |
| | CSS15 | CSS14 | CSS13 | CSS12 | CSS11 | CSS10 | CSS9 | CSS8 |
| 7:0 | R/W-0 | R/W-0 | R/W-0 | R/W-0 | R/W-0 | R/W-0 | R/W-0 | R/W-0 |
| | CSS7 | CSS6 | CSS5 | CSS4 | CSS3 | CSS2 | CSS1 | CSS0 |

Legend:

R = Readable bit

W = Writable bit

U = Unimplemented bit, read as '0'

-n = Value at POR

'1' = Bit is set

'0' = Bit is cleared

x = Bit is unknown

bit 31-0 **CSS31:CSS0**: Analog Common Scan Select bits

1 = Select ANx for input scan

0 = Skip ANx for input scan

Note 1: This bit is not available on 64-pin devices.

Note 1: In addition to setting the appropriate bits in this register, Class 1 and Class 2 analog inputs must select the STRIG input as the trigger source if they are to be scanned through the CSSx bits. Refer to the bit descriptions in the ADCTRGx registers for selecting the STRIG option.

2: If a Class 1 or Class 2 input is included in the scan by setting the CSSx bit to '1' and by setting the TRGSRCx<4:0> bits to STRIG mode (0b11), the user application must ensure that no other triggers are generated for that input using the RQCNVRT bit in the ADCCON3 register or the hardware input or any digital filter. Otherwise, the scan behavior is unpredictable.

PIC32MZ Embedded Connectivity with Floating Point Unit (EF) Family

REGISTER 28-11: ADCCSS2: ADC COMMON SCAN SELECT REGISTER 2

| Bit Range | Bit 31/23/15/7 | Bit 30/22/14/6 | Bit 29/21/13/5 | Bit 28/20/12/4 | Bit 27/19/11/3 | Bit 26/18/10/2 | Bit 25/17/9/1 | Bit 24/16/8/0 |
|-----------|----------------------|----------------------|----------------------|----------------------|----------------------|----------------------|----------------------|----------------------|
| 31:24 | U-0 | U-0 | U-0 | U-0 | U-0 | U-0 | U-0 | U-0 |
| | — | — | — | — | — | — | — | — |
| 23:16 | U-0 | U-0 | U-0 | U-0 | U-0 | U-0 | U-0 | U-0 |
| | — | — | — | — | — | — | — | — |
| 15:8 | U-0 | U-0 | U-0 | R/W-0 | R/W-0 | R/W-0 | R/W-0 | R/W-0 |
| | — | — | — | CSS44 | CSS43 | CSS42 ⁽²⁾ | CSS41 ⁽²⁾ | CSS40 ⁽²⁾ |
| 7:0 | R/W-0 | R/W-0 | R/W-0 | R/W-0 | R/W-0 | R/W-0 | R/W-0 | R/W-0 |
| | CSS39 ⁽²⁾ | CSS38 ⁽²⁾ | CSS37 ⁽²⁾ | CSS36 ⁽²⁾ | CSS35 ⁽²⁾ | CSS34 ⁽¹⁾ | CSS33 ⁽¹⁾ | CSS32 ⁽¹⁾ |

Legend:

R = Readable bit W = Writable bit U = Unimplemented bit, read as '0'
 -n = Value at POR '1' = Bit is set '0' = Bit is cleared x = Bit is unknown

bit 31-13 **Unimplemented:** Read as '0'

bit 12-0 **CSS44:CSS32:** Analog Common Scan Select bits
 Analog inputs 44 to 32 are always Class 3, as there are only 32 triggers available.
 1 = Select ANx for input scan
 0 = Skip ANx for input scan

- Note 1:** This bit is not available on 64-pin devices.
Note 2: This bit is not available on 64-pin and 100-pin devices.

PIC32MZ Embedded Connectivity with Floating Point Unit (EF) Family

REGISTER 28-12: ADCDSTAT1: ADC DATA READY STATUS REGISTER 1

| Bit Range | Bit 31/23/15/7 | Bit 30/22/14/6 | Bit 29/21/13/5 | Bit 28/20/12/4 | Bit 27/19/11/3 | Bit 26/18/10/2 | Bit 25/17/9/1 | Bit 24/16/8/0 |
|-----------|-----------------------|-----------------------|-----------------------|-----------------------|-----------------------|-----------------------|-----------------------|-----------------------|
| 31:24 | R-0, HS, HC | R-0, HS, HC | R-0, HS, HC | R-0, HS, HC | R-0, HS, HC | R-0, HS, HC | R-0, HS, HC | R-0, HS, HC |
| | ARDY31 ⁽¹⁾ | ARDY30 ⁽¹⁾ | ARDY29 ⁽¹⁾ | ARDY28 ⁽¹⁾ | ARDY27 ⁽¹⁾ | ARDY26 ⁽¹⁾ | ARDY25 ⁽¹⁾ | ARDY24 ⁽¹⁾ |
| 23:16 | R-0, HS, HC | R-0, HS, HC | R-0, HS, HC | R-0, HS, HC | R-0, HS, HC | R-0, HS, HC | R-0, HS, HC | R-0, HS, HC |
| | ARDY23 ⁽¹⁾ | ARDY22 ⁽¹⁾ | ARDY21 ⁽¹⁾ | ARDY20 ⁽¹⁾ | ARDY19 ⁽¹⁾ | ARDY18 | ARDY17 | ARDY16 |
| 15:8 | R-0, HS, HC | R-0, HS, HC | R-0, HS, HC | R-0, HS, HC | R-0, HS, HC | R-0, HS, HC | R-0, HS, HC | R-0, HS, HC |
| | ARDY15 | ARDY14 | ARDY13 | ARDY12 | ARDY11 | ARDY10 | ARDY9 | ARDY8 |
| 7:0 | R-0, HS, HC | R-0, HS, HC | R-0, HS, HC | R-0, HS, HC | R-0, HS, HC | R-0, HS, HC | R-0, HS, HC | R-0, HS, HC |
| | ARDY7 | ARDY6 | ARDY5 | ARDY4 | ARDY3 | ARDY2 | ARDY1 | ARDY0 |

| | | |
|-------------------|-------------------|--|
| Legend: | HS = Hardware Set | HC = Hardware Cleared |
| R = Readable bit | W = Writable bit | U = Unimplemented bit, read as '0' |
| -n = Value at POR | '1' = Bit is set | '0' = Bit is cleared x = Bit is unknown |

bit 31-0 **ARDY31:ARDY0:** Conversion Data Ready for Corresponding Analog Input Ready bits

1 = This bit is set when converted data is ready in the data register

0 = This bit is cleared when the associated data register is read

Note 1: This bit is not available on 64-pin devices.

REGISTER 28-13: ADCDSTAT2: ADC DATA READY STATUS REGISTER 2

| Bit Range | Bit 31/23/15/7 | Bit 30/22/14/6 | Bit 29/21/13/5 | Bit 28/20/12/4 | Bit 27/19/11/3 | Bit 26/18/10/2 | Bit 25/17/9/1 | Bit 24/16/8/0 |
|-----------|-----------------------|-----------------------|-----------------------|-----------------------|-----------------------|-----------------------|-----------------------|-----------------------|
| 31:24 | U-0 | U-0 | U-0 | U-0 | U-0 | U-0 | U-0 | U-0 |
| | — | — | — | — | — | — | — | — |
| 23:16 | U-0 | U-0 | U-0 | U-0 | U-0 | U-0 | U-0 | U-0 |
| | — | — | — | — | — | — | — | — |
| 15:8 | U-0 | U-0 | U-0 | R-0, HS, HC | R-0, HS, HC | R-0, HS, HC | R-0, HS, HC | R-0, HS, HC |
| | — | — | — | ARDY44 | ARDY43 | ARDY42 ⁽²⁾ | ARDY41 ⁽²⁾ | ARDY40 ⁽²⁾ |
| 7:0 | R-0, HS, HC | R-0, HS, HC | R-0, HS, HC | R-0, HS, HC | R-0, HS, HC | R-0, HS, HC | R-0, HS, HC | R-0, HS, HC |
| | ARDY39 ⁽²⁾ | ARDY38 ⁽²⁾ | ARDY37 ⁽²⁾ | ARDY36 ⁽²⁾ | ARDY35 ⁽²⁾ | ARDY34 ⁽¹⁾ | ARDY33 ⁽¹⁾ | ARDY32 ⁽¹⁾ |

| | | |
|-------------------|-------------------|--|
| Legend: | HS = Hardware Set | HC = Hardware Cleared |
| R = Readable bit | W = Writable bit | U = Unimplemented bit, read as '0' |
| -n = Value at POR | '1' = Bit is set | '0' = Bit is cleared x = Bit is unknown |

bit 31-13 **Unimplemented:** Read as '0'

bit 12-0 **ARDY44:ARDY32:** Conversion Data Ready for Corresponding Analog Input Ready bits

1 = This bit is set when converted data is ready in the data register

0 = This bit is cleared when the associated data register is read

Note 1: This bit is not available on 64-pin devices.

2: This bit is not available on 64 -pin and 100-pin devices.

PIC32MZ Embedded Connectivity with Floating Point Unit (EF) Family

REGISTER 28-14: ADCCMPENx: ADC DIGITAL COMPARATOR 'x' ENABLE REGISTER ('x' = 1 THROUGH 6)

| Bit Range | Bit 31/23/15/7 | Bit 30/22/14/6 | Bit 29/21/13/5 | Bit 28/20/12/4 | Bit 27/19/11/3 | Bit 26/18/10/2 | Bit 25/17/9/1 | Bit 24/16/8/0 |
|-----------|-----------------------|-----------------------|-----------------------|-----------------------|-----------------------|-----------------------|-----------------------|-----------------------|
| 31:24 | R/W-0 | R/W-0 | R/W-0 | R/W-0 | R/W-0 | R/W-0 | R/W-0 | R/W-0 |
| | CMPE31 ⁽¹⁾ | CMPE30 ⁽¹⁾ | CMPE29 ⁽¹⁾ | CMPE28 ⁽¹⁾ | CMPE27 ⁽¹⁾ | CMPE26 ⁽¹⁾ | CMPE25 ⁽¹⁾ | CMPE24 ⁽¹⁾ |
| 23:16 | R/W-0 | R/W-0 | R/W-0 | R/W-0 | R/W-0 | R/W-0 | R/W-0 | R/W-0 |
| | CMPE23 ⁽¹⁾ | CMPE22 ⁽¹⁾ | CMPE21 ⁽¹⁾ | CMPE20 ⁽¹⁾ | CMPE19 ⁽¹⁾ | CMPE18 | CMPE17 | CMPE16 |
| 15:8 | R/W-0 | R/W-0 | R/W-0 | R/W-0 | R/W-0 | R/W-0 | R/W-0 | R/W-0 |
| | CMPE15 | CMPE14 | CMPE13 | CMPE12 | CMPE11 | CMPE10 | CMPE9 | CMPE8 |
| 7:0 | R/W-0 | R/W-0 | R/W-0 | R/W-0 | R/W-0 | R/W-0 | R/W-0 | R/W-0 |
| | CMPE7 | CMPE6 | CMPE5 | CMPE4 | CMPE3 | CMPE2 | CMPE1 | CMPE0 |

Legend:

R = Readable bit W = Writable bit U = Unimplemented bit, read as '0'
-n = Value at POR '1' = Bit is set '0' = Bit is cleared x = Bit is unknown

bit 31-0 **CMPE31:CMPE0**: ADC Digital Comparator 'x' Enable bits

These bits enable conversion results corresponding to the Analog Input to be processed by the Digital Comparator. CMPE0 enables AN0, CMPE1 enables AN1, and so on.

Note 1: This bit is not available on 64-pin devices.

Note 1: CMPE_x = AN_x, where 'x' = 0-31 (Digital Comparator inputs are limited to AN0 through AN31).
Note 2: Changing the bits in this register while the Digital Comparator is enabled (ENDCMP = 1) can result in unpredictable behavior.

PIC32MZ Embedded Connectivity with Floating Point Unit (EF) Family

REGISTER 28-15: ADCCMPx: ADC DIGITAL COMPARATOR 'x' LIMIT VALUE REGISTER ('x' = 1 THROUGH 6)

| Bit Range | Bit 31/23/15/7 | Bit 30/22/14/6 | Bit 29/21/13/5 | Bit 28/20/12/4 | Bit 27/19/11/3 | Bit 26/18/10/2 | Bit 25/17/9/1 | Bit 24/16/8/0 |
|---------------------------------|-------------------|-------------------|-------------------|-------------------|-------------------|-------------------|------------------|------------------|
| 31:24 | R/W-0 | R/W-0 | R/W-0 | R/W-0 | R/W-0 | R/W-0 | R/W-0 | R/W-0 |
| DCMPHI<15:8> ^(1,2,3) | | | | | | | | |
| 23:16 | R/W-0 | R/W-0 | R/W-0 | R/W-0 | R/W-0 | R/W-0 | R/W-0 | R/W-0 |
| DCMPHI<7:0> ^(1,2,3) | | | | | | | | |
| 15:8 | R/W-0 | R/W-0 | R/W-0 | R/W-0 | R/W-0 | R/W-0 | R/W-0 | R/W-0 |
| DCMPLO<15:8> ^(1,2,3) | | | | | | | | |
| 7:0 | R/W-0 | R/W-0 | R/W-0 | R/W-0 | R/W-0 | R/W-0 | R/W-0 | R/W-0 |
| DCMPLO<7:0> ^(1,2,3) | | | | | | | | |

Legend:

| | | |
|-------------------|------------------|--|
| R = Readable bit | W = Writable bit | U = Unimplemented bit, read as '0' |
| -n = Value at POR | '1' = Bit is set | '0' = Bit is cleared x = Bit is unknown |

bit 31-16 **DCMPHI<15:0>**: Digital Comparator 'x' High Limit Value bits^(1,2,3)

These bits store the high limit value, which is used by digital comparator for comparisons with ADC converted data.

bit 15-0 **DCMPLO<15:0>**: Digital Comparator 'x' Low Limit Value bits^(1,2,3)

These bits store the low limit value, which is used by digital comparator for comparisons with ADC converted data.

- Note 1:** Changing these bits while the Digital Comparator is enabled (ENDCMP = 1) can result in unpredictable behavior.
- 2:** The format of the limit values should match the format of the ADC converted value in terms of sign and fractional settings.
- 3:** For Digital Comparator 0 used in CVD mode, the DCMPHI<15:0> and DCMPLO<15:0> bits must always be specified in signed format, as the CVD output data is differential and is always signed.

PIC32MZ Embedded Connectivity with Floating Point Unit (EF) Family

REGISTER 28-16: ADCFLTRx: ADC DIGITAL FILTER 'x' REGISTER ('x' = 1 THROUGH 6)

| Bit Range | Bit 31/23/15/7 | Bit 30/22/14/6 | Bit 29/21/13/5 | Bit 28/20/12/4 | Bit 27/19/11/3 | Bit 26/18/10/2 | Bit 25/17/9/1 | Bit 24/16/8/0 |
|-----------|----------------|----------------|----------------|----------------|----------------|----------------|---------------|---------------|
| 31:24 | R/W-0 | R/W-0 | R/W-0 | R/W-0 | R/W-0 | R/W-0 | R/W-0 | R-0, HS, HC |
| | AFEN | DATA16EN | DFMODE | OVRSAM<2:0> | | | AFGIEN | AFRDY |
| 23:16 | U-0 | U-0 | U-0 | R/W-0 | R/W-0 | R/W-0 | R/W-0 | R/W-0 |
| | — | — | — | CHNLID<4:0> | | | | |
| 15:8 | R-0, HS, HC | R-0, HS, HC | R-0, HS, HC | R-0, HS, HC | R-0, HS, HC | R-0, HS, HC | R-0, HS, HC | R-0, HS, HC |
| | FLTRDATA<15:8> | | | | | | | |
| 7:0 | R-0, HS, HC | R-0, HS, HC | R-0, HS, HC | R-0, HS, HC | R-0, HS, HC | R-0, HS, HC | R-0, HS, HC | R-0, HS, HC |
| | FLTRDATA<7:0> | | | | | | | |

| | | |
|-------------------|-------------------|--|
| Legend: | HS = Hardware Set | HC = Hardware Cleared |
| R = Readable bit | W = Writable bit | U = Unimplemented bit, read as '0' |
| -n = Value at POR | '1' = Bit is set | '0' = Bit is cleared x = Bit is unknown |

- bit 31 **AFEN:** Digital Filter 'x' Enable bit
1 = Digital filter is enabled
0 = Digital filter is disabled and the AFRDY status bit is cleared
- bit 30 **DATA16EN:** Filter Significant Data Length bit
1 = All 16 bits of the filter output data are significant
0 = Only the first 12 bits are significant, followed by four zeros
Note: This bit is significant only if DFMODE = 1 (Averaging Mode) and FRACT (ADCCON1<23>) = 1 (Fractional Output Mode).
- bit **DFMODE:** ADC Filter Mode bit
1 = Filter 'x' works in Averaging mode
0 = Filter 'x' works in Oversampling Filter mode (default)
- bit 28-26 **OVRSAM<2:0>:** Oversampling Filter Ratio bits
If DFMODE is '0':
111 = 128 samples (shift sum 3 bits to right, output data is in 15.1 format)
110 = 32 samples (shift sum 2 bits to right, output data is in 14.1 format)
101 = 8 samples (shift sum 1 bit to right, output data is in 13.1 format)
100 = 2 samples (shift sum 0 bits to right, output data is in 12.1 format)
011 = 256 samples (shift sum 4 bits to right, output data is 16 bits)
010 = 64 samples (shift sum 3 bits to right, output data is 15 bits)
001 = 16 samples (shift sum 2 bits to right, output data is 14 bits)
000 = 4 samples (shift sum 1 bit to right, output data is 13 bits)
- If DFMODE is '1':
111 = 256 samples (256 samples to be averaged)
110 = 128 samples (128 samples to be averaged)
101 = 64 samples (64 samples to be averaged)
100 = 32 samples (32 samples to be averaged)
011 = 16 samples (16 samples to be averaged)
010 = 8 samples (8 samples to be averaged)
001 = 4 samples (4 samples to be averaged)
000 = 2 samples (2 samples to be averaged)
- bit 25 **AFGIEN:** Digital Filter 'x' Interrupt Enable bit
1 = Digital filter interrupt is enabled and is generated by the AFRDY status bit
0 = Digital filter is disabled

PIC32MZ Embedded Connectivity with Floating Point Unit (EF) Family

REGISTER 28-16: ADCFLTRx: ADC DIGITAL FILTER 'x' REGISTER ('x' = 1 THROUGH 6)

bit 24 **AFRDY**: Digital Filter 'x' Data Ready Status bit
1 = Data is ready in the FLTRDATA<15:0> bits
0 = Data is not ready

Note: This bit is cleared by reading the FLTRDATA<15:0> bits or by disabling the Digital Filter module (by setting AFEN to '0').

bit 23-21 **Unimplemented**: Read as '0'

bit 20-16 **CHNLID<4:0>**: Digital Filter Analog Input Selection bits
These bits specify the analog input to be used as the oversampling filter data source.
11111 = AN31
•
•
•
00010 = AN2
00001 = AN1
00000 = AN0

Note: Only the first 32 analog inputs (Class 1 and Class 2) can use a digital filter.

bit 15-0 **FLTRDATA<15:0>**: Digital Filter 'x' Data Output Value bits
The filter output data is as per the fractional format set in the FRACT (ADCCON1<23>) bit. The FRACT bit should not be changed while the filter is enabled. Changing the state of the FRACT bit after the operation of the filter ended will not update the value of FLTRDATA<15:0> to reflect the new format.

PIC32MZ Embedded Connectivity with Floating Point Unit (EF) Family

REGISTER 28-17: ADCTRG1: ADC TRIGGER SOURCE 1 REGISTER

| Bit Range | Bit 31/23/15/7 | Bit 30/22/14/6 | Bit 29/21/13/5 | Bit 28/20/12/4 | Bit 27/19/11/3 | Bit 26/18/10/2 | Bit 25/17/9/1 | Bit 24/16/8/0 | |
|-----------|----------------|----------------|----------------|----------------|----------------|----------------|---------------|---------------|--|
| 31:24 | U-0 | U-0 | U-0 | R/W-0 | R/W-0 | R/W-0 | R/W-0 | R/W-0 | |
| | — | — | — | TRGSRC3<4:0> | | | | | |
| 23:16 | U-0 | U-0 | U-0 | R/W-0 | R/W-0 | R/W-0 | R/W-0 | R/W-0 | |
| | — | — | — | TRGSRC2<4:0> | | | | | |
| 15:8 | U-0 | U-0 | U-0 | R/W-0 | R/W-0 | R/W-0 | R/W-0 | R/W-0 | |
| | — | — | — | TRGSRC1<4:0> | | | | | |
| 7:0 | U-0 | U-0 | U-0 | R/W-0 | R/W-0 | R/W-0 | R/W-0 | R/W-0 | |
| | — | — | — | TRGSRC0<4:0> | | | | | |

Legend:

R = Readable bit W = Writable bit U = Unimplemented bit, read as '0'
 -n = Value at POR '1' = Bit is set '0' = Bit is cleared x = Bit is unknown

bit 31-29 **Unimplemented:** Read as '0'

bit 28-24 **TRGSRC3<4:0>**: Trigger Source for Conversion of Analog Input AN3 Select bits

11111 = Reserved

•
•
•

01101 = Reserved

01100 = Comparator 2 (COUT)

01011 = Comparator 1 (COUT)

01010 = OCMP5

01001 = OCMP3

01000 = OCMP1

00111 = TMR5 match

00110 = TMR3 match

00101 = TMR1 match

00100 = INT0 External interrupt

00011 = STRIG

00010 = Global level software trigger (GLSWTRG)

00001 = Global software edge Trigger (GSWTRG)

00000 = No Trigger

For STRIG, in addition to setting the trigger, it also requires programming of the STRGSRC<4:0> bits (ADCCON1<20:16>) to select the trigger source, and requires the appropriate CSS bits to be set in the ADCCSSx registers.

bit 23-21 **Unimplemented:** Read as '0'

bit 20-16 **TRGSRC2<4:0>**: Trigger Source for Conversion of Analog Input AN2 Select bits
 See bits 28-24 for bit value definitions.

bit 15-13 **Unimplemented:** Read as '0'

bit 12-8 **TRGSRC1<4:0>**: Trigger Source for Conversion of Analog Input AN1 Select bits
 See bits 28-24 for bit value definitions.

bit 7-5 **Unimplemented:** Read as '0'

bit 4-0 **TRGSRC0<4:0>**: Trigger Source for Conversion of Analog Input AN0 Select bits
 See bits 28-24 for bit value definitions.

PIC32MZ Embedded Connectivity with Floating Point Unit (EF) Family

REGISTER 28-18: ADCTRG2: ADC TRIGGER SOURCE 2 REGISTER

| Bit Range | Bit 31/23/15/7 | Bit 30/22/14/6 | Bit 29/21/13/5 | Bit 28/20/12/4 | Bit 27/19/11/3 | Bit 26/18/10/2 | Bit 25/17/9/1 | Bit 24/16/8/0 |
|-----------|----------------|----------------|----------------|----------------|----------------|----------------|---------------|---------------|
| 31:24 | U-0 | U-0 | U-0 | R/W-0 | R/W-0 | R/W-0 | R/W-0 | R/W-0 |
| | — | — | — | TRGSRC7<4:0> | | | | |
| 23:16 | U-0 | U-0 | U-0 | R/W-0 | R/W-0 | R/W-0 | R/W-0 | R/W-0 |
| | — | — | — | TRGSRC6<4:0> | | | | |
| 15:8 | U-0 | U-0 | U-0 | R/W-0 | R/W-0 | R/W-0 | R/W-0 | R/W-0 |
| | — | — | — | TRGSRC5<4:0> | | | | |
| 7:0 | U-0 | U-0 | U-0 | R/W-0 | R/W-0 | R/W-0 | R/W-0 | R/W-0 |
| | — | — | — | TRGSRC4<4:0> | | | | |

Legend:

R = Readable bit W = Writable bit U = Unimplemented bit, read as '0'
 -n = Value at POR '1' = Bit is set '0' = Bit is cleared x = Bit is unknown

bit 31-29 **Unimplemented:** Read as '0'

bit 28-24 **TRGSRC7<4:0>**: Trigger Source for Conversion of Analog Input AN7 Select bits

11111 = Reserved

•
•
•

01101 = Reserved

01100 = Comparator 2 (COUT)

01011 = Comparator 1 (COUT)

01010 = OCMP5

01001 = OCMP3

01000 = OCMP1

00111 = TMR5 match

00110 = TMR3 match

00101 = TMR1 match

00100 = INT0 External interrupt

00011 = STRIG

00010 = Global level software trigger (GLSWTRG)

00001 = Global software edge Trigger (GSWTRG)

00000 = No Trigger

For STRIG, in addition to setting the trigger, it also requires programming of the STRGSRC<4:0> bits (ADCCON1<20:16>) to select the trigger source, and requires the appropriate CSS bits to be set in the ADCCSSx registers.

bit 23-21 **Unimplemented:** Read as '0'

bit 20-16 **TRGSRC6<4:0>**: Trigger Source for Conversion of Analog Input AN6 Select bits
 See bits 28-24 for bit value definitions.

bit 15-13 **Unimplemented:** Read as '0'

bit 12-8 **TRGSRC5<4:0>**: Trigger Source for Conversion of Analog Input AN5 Select bits
 See bits 28-24 for bit value definitions.

bit 7-5 **Unimplemented:** Read as '0'

bit 4-0 **TRGSRC4<4:0>**: Trigger Source for Conversion of Analog Input AN4 Select bits
 See bits 28-24 for bit value definitions.

PIC32MZ Embedded Connectivity with Floating Point Unit (EF) Family

REGISTER 28-19: ADCTRG3: ADC TRIGGER SOURCE 3 REGISTER

| Bit Range | Bit 31/23/15/7 | Bit 30/22/14/6 | Bit 29/21/13/5 | Bit 28/20/12/4 | Bit 27/19/11/3 | Bit 26/18/10/2 | Bit 25/17/9/1 | Bit 24/16/8/0 |
|-----------|----------------|----------------|----------------|----------------|----------------|----------------|---------------|---------------|
| 31:24 | U-0 | U-0 | U-0 | R/W-0 | R/W-0 | R/W-0 | R/W-0 | R/W-0 |
| | — | — | — | TRGSRC11<4:0> | | | | |
| 23:16 | U-0 | U-0 | U-0 | R/W-0 | R/W-0 | R/W-0 | R/W-0 | R/W-0 |
| | — | — | — | TRGSRC10<4:0> | | | | |
| 15:8 | U-0 | U-0 | U-0 | R/W-0 | R/W-0 | R/W-0 | R/W-0 | R/W-0 |
| | — | — | — | TRGSRC9<4:0> | | | | |
| 7:0 | U-0 | U-0 | U-0 | R/W-0 | R/W-0 | R/W-0 | R/W-0 | R/W-0 |
| | — | — | — | TRGSRC8<4:0> | | | | |

Legend:

R = Readable bit W = Writable bit U = Unimplemented bit, read as '0'
 -n = Value at POR '1' = Bit is set '0' = Bit is cleared x = Bit is unknown

bit 31-29 **Unimplemented:** Read as '0'

bit 28-24 **TRGSRC11<4:0>**: Trigger Source for Conversion of Analog Input AN11 Select bits

11111 = Reserved

•
•
•

01101 = Reserved

01100 = Comparator 2 (COUT)

01011 = Comparator 1 (COUT)

01010 = OCMP5

01001 = OCMP3

01000 = OCMP1

00111 = TMR5 match

00110 = TMR3 match

00101 = TMR1 match

00100 = INT0 External interrupt

00011 = STRIG

00010 = Global level software trigger (GLSWTRG)

00001 = Global software edge Trigger (GSWTRG)

00000 = No Trigger

For STRIG, in addition to setting the trigger, it also requires programming of the STRGSRC<4:0> bits (ADCCON1<20:16>) to select the trigger source, and requires the appropriate CSS bits to be set in the ADCCSSx registers.

bit 23-21 **Unimplemented:** Read as '0'

bit 20-16 **TRGSRC10<4:0>**: Trigger Source for Conversion of Analog Input AN10 Select bits

See bits 28-24 for bit value definitions.

bit 15-13 **Unimplemented:** Read as '0'

bit 12-8 **TRGSRC9<4:0>**: Trigger Source for Conversion of Analog Input AN9 Select bits

See bits 28-24 for bit value definitions.

bit 7-5 **Unimplemented:** Read as '0'

bit 4-0 **TRGSRC8<4:0>**: Trigger Source for Conversion of Analog Input AN8 Select bits

See bits 28-24 for bit value definitions.

PIC32MZ Embedded Connectivity with Floating Point Unit (EF) Family

REGISTER 28-20: ADCCMPCON1: ADC DIGITAL COMPARATOR 1 CONTROL REGISTER

| Bit Range | Bit 31/23/15/7 | Bit 30/22/14/6 | Bit 29/21/13/5 | Bit 28/20/12/4 | Bit 27/19/11/3 | Bit 26/18/10/2 | Bit 25/17/9/1 | Bit 24/16/8/0 |
|--|----------------|----------------|----------------|----------------|----------------|----------------|---------------|---------------|
| 31:24 | R-0, HS, HC | R-0, HS, HC | R-0, HS, HC | R-0, HS, HC | R-0, HS, HC | R-0, HS, HC | R-0, HS, HC | R-0, HS, HC |
| CVDDATA<15:8> | | | | | | | | |
| 23:16 | R-0, HS, HC | R-0, HS, HC | R-0, HS, HC | R-0, HS, HC | R-0, HS, HC | R-0, HS, HC | R-0, HS, HC | R-0, HS, HC |
| CVDDATA<7:0> | | | | | | | | |
| 15:8 | U-0 | U-0 | R-0, HS, HC | R-0, HS, HC | R-0, HS, HC | R-0, HS, HC | R-0, HS, HC | R-0, HS, HC |
| AINID<5:0> | | | | | | | | |
| 7:0 | R/W-0 | R/W-0 | R-0, HS, HC | R/W-0 | R/W-0 | R/W-0 | R/W-0 | R/W-0 |
| ENDCMP DCMPGIEN DCMPEDE IEBTWN IEHIHI IEHILO IELOHI IELOLO | | | | | | | | |

| | | |
|-------------------|-------------------|--|
| Legend: | HS = Hardware Set | HC = Hardware Cleared |
| R = Readable bit | W = Writable bit | U = Unimplemented bit, read as '0' |
| -n = Value at POR | '1' = Bit is set | '0' = Bit is cleared x = Bit is unknown |

bit 31-16 **CVDDATA<15:0>**: CVD Data Status bits

In CVD mode, these bits obtain the CVD differential output data (subtraction of CVD positive and negative measurement), whenever a Digital Comparator interrupt is generated. The value in these bits is compliant with the FRACT bit (ADCCON1<23>) and is always signed.

bit 15-14 **Unimplemented**: Read as '0'

bit 13-8 **AINID<5:0>**: Digital Comparator 0 Analog Input Identification (ID) bits

When a digital comparator event occurs (DCMPED = 1), these bits identify the analog input being monitored by Digital Comparator 0.

Note: In normal ADC mode, only analog inputs <31:0> can be processed by the Digital Comparator 0. The Digital Comparator 0 also supports the CVD mode, in which all Class 2 and Class 3 analog inputs may be stored in the AINID<5:0> bits.

111111 = Reserved

•
•
•

101101 = Reserved

101100 = AN44 is being monitored

101011 = AN43 is being monitored

•
•

000001 = AN1 is being monitored

000000 = AN0 is being monitored

bit 7 **ENDCMP**: Digital Comparator 0 Enable bit

1 = Digital Comparator 0 is enabled

0 = Digital Comparator 0 is not enabled, and the DCMPEDE status bit (ADCCMP0CON<5>) is cleared

bit 6 **DCMPGIEN**: Digital Comparator 0 Global Interrupt Enable bit

1 = A Digital Comparator 0 interrupt is generated when the DCMPEDE status bit (ADCCMP0CON<5>) is set

0 = A Digital Comparator 0 interrupt is disabled

bit 5 **DCMPED**: Digital Comparator 0 "Output True" Event Status bit

The logical conditions under which the digital comparator gets "True" are defined by the IEBTWN, IEHIHI, IEHILO, IELOHI, and IELOLO bits.

Note: This bit is cleared by reading the AINID<5:0> bits or by disabling the Digital Comparator module (by setting ENDCMP to '0').

1 = Digital Comparator 0 output true event has occurred (output of Comparator is '1')

0 = Digital Comparator 0 output is false (output of comparator is '0')

bit 4 **IEBTWN**: Between Low/High Digital Comparator 0 Event bit

1 = Generate a digital comparator event when DCMPEDE<15:0> ≤ DATA<31:0> < DCMPEDE<15:0>

0 = Do not generate a digital comparator event

PIC32MZ Embedded Connectivity with Floating Point Unit (EF) Family

REGISTER 28-20: ADCCMPCON1: ADC DIGITAL COMPARATOR 1 CONTROL REGISTER

- bit 3 **IEHIHI:** High/High Digital Comparator 0 Event bit
1 = Generate a Digital Comparator 0 Event when $DCMPHI<15:0> \leq DATA<31:0>$
0 = Do not generate an event
- bit 2 **IEHILO:** High/Low Digital Comparator 0 Event bit
1 = Generate a Digital Comparator 0 Event when $DATA<31:0> < DCMPHI<15:0>$
0 = Do not generate an event
- bit 1 **IELOHI:** Low/High Digital Comparator 0 Event bit
1 = Generate a Digital Comparator 0 Event when $DCMPLO<15:0> \leq DATA<31:0>$
0 = Do not generate an event
- bit 0 **IELOLO:** Low/Low Digital Comparator 0 Event bit
1 = Generate a Digital Comparator 0 Event when $DATA<31:0> < DCMPLO<15:0>$
0 = Do not generate an event

PIC32MZ Embedded Connectivity with Floating Point Unit (EF) Family

REGISTER 28-21: ADCCMPxCONx: ADC DIGITAL COMPARATOR 'x' CONTROL REGISTER ('x' = 2 THROUGH 6)

| Bit Range | Bit 31/23/15/7 | Bit 30/22/14/6 | Bit 29/21/13/5 | Bit 28/20/12/4 | Bit 27/19/11/3 | Bit 26/18/10/2 | Bit 25/17/9/1 | Bit 24/16/8/0 |
|-----------|-----------------|-------------------|-----------------------|---------------------------|-----------------|-----------------|-----------------|-----------------|
| 31:24 | U-0 — | U-0 — | U-0 — | U-0 — | U-0 — | U-0 — | U-0 — | U-0 — |
| 23:16 | U-0 — | U-0 — | U-0 — | U-0 — | U-0 — | U-0 — | U-0 — | U-0 — |
| 15:8 | U-0 — | U-0 — | U-0 — | R-0, HS, HC AINID<4:0> | | | | |
| 7:0 | R/W-0 ENDCMP | R/W-0 DCMPGIEN | R-0, HS, HC DCMPED | R/W-0 IEBTWN | R/W-0 IEHIHI | R/W-0 IEHILO | R/W-0 IELOHI | R/W-0 IELOLO |

| | | |
|-------------------|-------------------|--|
| Legend: | HS = Hardware Set | HC = Hardware Cleared |
| R = Readable bit | W = Writable bit | U = Unimplemented bit, read as '0' |
| -n = Value at POR | '1' = Bit is set | '0' = Bit is cleared x = Bit is unknown |

bit 31-13 **Unimplemented:** Read as '0'

bit 12-8 **AINID<4:0>:** Digital Comparator 'x' Analog Input Identification (ID) bits

When a digital comparator event occurs (DCMPED = 1), these bits identify the analog input being monitored by the Digital Comparator.

Note: Only analog inputs <31:0> can be processed by the Digital Comparator module 'x' ('x' = 1-5).

11111 = AN31 is being monitored

11110 = AN30 is being monitored

•
•
•

00001 = AN1 is being monitored

00000 = AN0 is being monitored

bit 7 **ENDCMP:** Digital Comparator 'x' Enable bit

1 = Digital Comparator 'x' is enabled

0 = Digital Comparator 'x' is not enabled, and the DCMPED status bit (ADCCMPxCON<5>) is cleared

bit 6 **DCMPGIEN:** Digital Comparator 'x' Global Interrupt Enable bit

1 = A Digital Comparator 'x' interrupt is generated when the DCMPED status bit (ADCCMPxCON<5>) is set

0 = A Digital Comparator 'x' interrupt is disabled

bit 5 **DCMPED:** Digital Comparator 'x' "Output True" Event Status bit

The logical conditions under which the digital comparator gets "True" are defined by the IEBTWN, IEHIHI, IEHILO, IELOHI and IELOLO bits.

Note: This bit is cleared by reading the AINID<5:0> bits (ADCCMP0CON<13:8>) or by disabling the Digital Comparator module (by setting ENDCMP to '0').

1 = Digital Comparator 'x' output true event has occurred (output of Comparator is '1')

0 = Digital Comparator 'x' output is false (output of Comparator is '0')

bit 4 **IEBTWN:** Between Low/High Digital Comparator 'x' Event bit

1 = Generate a digital comparator event when the DCMPL0<15:0> bits ≤ DATA<31:0> bits < DCMPHI<15:0> bits

0 = Do not generate a digital comparator event

bit 3 **IEHIHI:** High/High Digital Comparator 'x' Event bit

1 = Generate a Digital Comparator 'x' Event when the DCMPHI<15:0> bits ≤ DATA<31:0> bits

0 = Do not generate an event

bit 2 **IEHILO:** High/Low Digital Comparator 'x' Event bit

1 = Generate a Digital Comparator 'x' Event when the DATA<31:0> bits < DCMPHI<15:0> bits

0 = Do not generate an event

PIC32MZ Embedded Connectivity with Floating Point Unit (EF) Family

REGISTER 28-21: ADCCMPCONx: ADC DIGITAL COMPARATOR 'x' CONTROL REGISTER ('x' = 2 THROUGH 6) (CONTINUED)

- bit 1 **IELOHI:** Low/High Digital Comparator 'x' Event bit
 1 = Generate a Digital Comparator 'x' Event when the DCMPL0<15:0> bits \leq DATA<31:0> bits
 0 = Do not generate an event
- bit 0 **IELOLO:** Low/Low Digital Comparator 'x' Event bit
 1 = Generate a Digital Comparator 'x' Event when the DATA<31:0> bits < DCMPL0<15:0> bits
 0 = Do not generate an event

PIC32MZ Embedded Connectivity with Floating Point Unit (EF) Family

REGISTER 28-22: ADCFSTAT: ADC FIFO STATUS REGISTER

| Bit Range | Bit 31/23/15/7 | Bit 30/22/14/6 | Bit 29/21/13/5 | Bit 28/20/12/4 | Bit 27/19/11/3 | Bit 26/18/10/2 | Bit 25/17/9/1 | Bit 24/16/8/0 |
|-----------|-------------------|-------------------|-------------------|-------------------|-------------------|-------------------|------------------|------------------|
| 31:24 | R/W-0 | U-0 | U-0 | R/W-0 | R/W-0 | R/W-0 | R/W-0 | R/W-0 |
| | FEN | — | — | ADC4EN | ADC3EN | ADC2EN | ADC1EN | ADC0EN |
| 23:16 | R/W-0 | R-0, HS, HC | R-0, HS, HC | U-0 | U-0 | U-0 | U-0 | U-0 |
| | FIEN | FRDY | FWROVERR | — | — | — | — | — |
| 15:8 | R-0 | R-0 | R-0 | R-0 | R-0 | R-0 | R-0 | R-0 |
| | FCNT<7:0> | | | | | | | |
| 7:0 | R-0 | U-0 | U-0 | U-0 | U-0 | R-0 | R-0 | R-0 |
| | FSIGN | — | — | — | — | ADCID<2:0> | | |

| | | |
|-------------------|-------------------|--|
| Legend: | HS = Hardware Set | HC = Hardware Cleared |
| R = Readable bit | W = Writable bit | U = Unimplemented bit, read as '0' |
| -n = Value at POR | '1' = Bit is set | '0' = Bit is cleared x = Bit is unknown |

- bit 31 **FEN:** FIFO Enable bit
1 = FIFO is enabled
0 = FIFO is disabled; no data is being saved into the FIFO
- bit 30-29 **Unimplemented:** Read as '0'
- bit 28-24 **ADC4EN:ADC0EN:** ADCx Enable bits ('x' = 0 through 4)
1 = Converted output data of ADCx is stored in the FIFO
0 = Converted output data of ADCx is not stored in the FIFO
Note: While using FIFO, the output data is additionally stored in the respective output data register (ADCDATAx).
- bit 23 **FIEN:** FIFO Interrupt Enable bit
1 = FIFO interrupts are enabled; an interrupt is generated once the FRDY bit is set
0 = FIFO interrupts are disabled
- bit 22 **FRDY:** FIFO Data Ready Interrupt Status bit
1 = FIFO has data to be read
0 = No data is available in the FIFO
Note: This bit is cleared when the FIFO output data in ADCFIFO has been read and there is no additional data ready in the FIFO (that is, the FIFO is empty).
- bit 21 **FWROVERR:** FIFO Write Overflow Error Status bit
1 = A write overflow error in the FIFO has occurred (circular FIFO)
0 = A write overflow error in the FIFO has not occurred
Note: This bit is cleared after ADCFSTAT<23:16> are read by software.
- bit 15-8 **FCNT<7:0>:** FIFO Data Entry Count Status bit
The value in these bits indicates the number of data entries in the FIFO.
- bit 7 **FSIGN:** FIFO Sign Setting bit
This bit reflects the sign of data stored in the ADCFIFO register.
- bit 6-3 **Unimplemented:** Read as '0'
- bit 2-0 **ADCID<2:0>:** ADCx Identifier bits ('x' = 0 through 6)
These bits specify the ADC module whose data is stored in the FIFO.
111 = Reserved
110 = Converted data of ADC6 is stored in FIFO
•
•
•
000 = Converted data of ADC0 is stored in FIFO

PIC32MZ Embedded Connectivity with Floating Point Unit (EF) Family

REGISTER 28-23: ADCFIFO: ADC FIFO DATA REGISTER

| Bit Range | Bit 31/23/15/7 | Bit 30/22/14/6 | Bit 29/21/13/5 | Bit 28/20/12/4 | Bit 27/19/11/3 | Bit 26/18/10/2 | Bit 25/17/9/1 | Bit 24/16/8/0 |
|-------------|-------------------|-------------------|-------------------|-------------------|-------------------|-------------------|------------------|------------------|
| 31:24 | R-0 | R-0 | R-0 | R-0 | R-0 | R-0 | R-0 | R-0 |
| DATA<31:24> | | | | | | | | |
| 23:16 | R-0 | R-0 | R-0 | R-0 | R-0 | R-0 | R-0 | R-0 |
| DATA<23:16> | | | | | | | | |
| 15:8 | R-0 | R-0 | R-0 | R-0 | R-0 | R-0 | R-0 | R-0 |
| DATA<15:8> | | | | | | | | |
| 7:0 | R-0 | R-0 | R-0 | R-0 | R-0 | R-0 | R-0 | R-0 |
| DATA<7:0> | | | | | | | | |

Legend:

R = Readable bit W = Writable bit U = Unimplemented bit, read as '0'
 -n = Value at POR '1' = Bit is set '0' = Bit is cleared x = Bit is unknown

bit 31-0 **DATA<31:0>**: FIFO Data Output Value bits

Note: When an alternate input is used as the input source for a dedicated ADC module, the data output is still read from the Primary input Data Output Register.

PIC32MZ Embedded Connectivity with Floating Point Unit (EF) Family

REGISTER 28-24: ADCBASE: ADC BASE REGISTER

| Bit Range | Bit 31/23/15/7 | Bit 30/22/14/6 | Bit 29/21/13/5 | Bit 28/20/12/4 | Bit 27/19/11/3 | Bit 26/18/10/2 | Bit 25/17/9/1 | Bit 24/16/8/0 |
|-----------|-------------------|-------------------|-------------------|-------------------|-------------------|-------------------|------------------|------------------|
| 31:24 | U-0 | U-0 | U-0 | U-0 | U-0 | U-0 | U-0 | U-0 |
| | — | — | — | — | — | — | — | — |
| 23:16 | U-0 | U-0 | U-0 | U-0 | U-0 | U-0 | U-0 | U-0 |
| | — | — | — | — | — | — | — | — |
| 15:8 | R/W-0 | R/W-0 | R/W-0 | R/W-0 | R/W-0 | R/W-0 | R/W-0 | R/W-0 |
| | ADCBASE<15:8> | | | | | | | |
| 7:0 | R/W-0 | R/W-0 | R/W-0 | R/W-0 | R/W-0 | R/W-0 | R/W-0 | R/W-0 |
| | ADCBASE<7:0> | | | | | | | |

Legend:

R = Readable bit W = Writable bit U = Unimplemented bit, read as '0'
 -n = Value at POR '1' = Bit is set '0' = Bit is cleared x = Bit is unknown

bit 31-0 **Unimplemented:** Read as '0'

bit 15-0 **ADCBASE<15:0>:** ADC ISR Base Address bits

This register, when read, contains the base address of the user's ADC ISR jump table. The interrupt vector address is determined by the IRQVS<2:0> bits of the ADCCON1 register specifying the amount of left shift done to the ARDYx status bits in the ADCDSTAT1 and ADCDSTAT2 registers, prior to adding with ADCBASE register.

Interrupt Vector Address = Read Value of ADCBASE and Read Value of ADCBASE = Value written to ADCBASE + x << IRQVS<2:0>, where 'x' is the smallest active analog input ID from the ADCDSTAT1 or ADCDSTAT2 registers (which has highest priority).

PIC32MZ Embedded Connectivity with Floating Point Unit (EF) Family

REGISTER 28-25: ADCDATAx: ADC OUTPUT DATA REGISTER ('x' = 0 THROUGH 44)

| Bit Range | Bit 31/23/15/7 | Bit 30/22/14/6 | Bit 29/21/13/5 | Bit 28/20/12/4 | Bit 27/19/11/3 | Bit 26/18/10/2 | Bit 25/17/9/1 | Bit 24/16/8/0 |
|-------------|-------------------|-------------------|-------------------|-------------------|-------------------|-------------------|------------------|------------------|
| 31:24 | R-0 | R-0 | R-0 | R-0 | R-0 | R-0 | R-0 | R-0 |
| DATA<31:24> | | | | | | | | |
| 23:16 | R-0 | R-0 | R-0 | R-0 | R-0 | R-0 | R-0 | R-0 |
| DATA<23:16> | | | | | | | | |
| 15:8 | R-0 | R-0 | R-0 | R-0 | R-0 | R-0 | R-0 | R-0 |
| DATA<15:8> | | | | | | | | |
| 7:0 | R-0 | R-0 | R-0 | R-0 | R-0 | R-0 | R-0 | R-0 |
| DATA<7:0> | | | | | | | | |

Legend:

R = Readable bit W = Writable bit U = Unimplemented bit, read as '0'
 -n = Value at POR '1' = Bit is set '0' = Bit is cleared x = Bit is unknown

bit 31-0 **DATA<31:0>**: ADC Converted Data Output bits.

- Note 1:** The registers, ADCDATA19 through ADCDATA34, are not available on 64-pin devices.
Note 2: The registers, ADCDATA35 through ADCDATA44, are not available on 64-pin and 100-pin devices.
Note 3: When an alternate input is used as the input source for a dedicated ADC module, the data output is still read from the Primary input Data Output Register.
Note 4: Reading the ADCDATAx register value after changing the FRACT bit converts the data into the format specified by FRACT bit.

PIC32MZ Embedded Connectivity with Floating Point Unit (EF) Family

REGISTER 28-26: ADCTRGSNS: ADC TRIGGER LEVEL/EDGE SENSITIVITY REGISTER

| Bit Range | Bit 31/23/15/7 | Bit 30/22/14/6 | Bit 29/21/13/5 | Bit 28/20/12/4 | Bit 27/19/11/3 | Bit 26/18/10/2 | Bit 25/17/9/1 | Bit 24/16/8/0 |
|-----------|-------------------|-------------------|-------------------|-------------------|-------------------|-------------------|------------------|------------------|
| 31:24 | U-0 | U-0 | U-0 | U-0 | U-0 | U-0 | U-0 | U-0 |
| | — | — | — | — | — | — | — | — |
| 23:16 | U-0 | U-0 | U-0 | U-0 | U-0 | U-0 | U-0 | U-0 |
| | — | — | — | — | — | — | — | — |
| 15:8 | U-0 | U-0 | U-0 | U-0 | R/W-0 | R/W-0 | R/W-0 | R/W-0 |
| | — | — | — | — | LVL11 | LVL10 | LVL9 | LVL8 |
| 7:0 | R/W-0 | R/W-0 | R/W-0 | R/W-0 | R/W-0 | R/W-0 | R/W-0 | R/W-0 |
| | LVL7 | LVL6 | LVL5 | LVL4 | LVL3 | LVL2 | LVL1 | LVL0 |

Legend:

R = Readable bit W = Writable bit U = Unimplemented bit, read as '0'
 -n = Value at POR '1' = Bit is set '0' = Bit is cleared x = Bit is unknown

bit 31-12 **Unimplemented:** Read as '0'

bit 11 **LVL11:LVL0:** Trigger Level and Edge Sensitivity bits

1 = Analog input is sensitive to the high level of its trigger (level sensitivity implies retriggering as long as the trigger signal remains high)

0 = Analog input is sensitive to the positive edge of its trigger (this is the value after a reset)

Note 1: This register specifies the trigger level for analog inputs 0 to 31.

2: The higher analog input ID belongs to Class 3, and therefore, is only scan triggered. All Class 3 analog inputs use the Scan Trigger, for which the level/edge is defined by the STRGLVL bit (ADCCON1<3>).

PIC32MZ Embedded Connectivity with Floating Point Unit (EF) Family

REGISTER 28-27: ADCxTIME: DEDICATED ADCx TIMING REGISTER 'x' ('x' = 0 THROUGH 4)

| Bit Range | Bit 31/23/15/7 | Bit 30/22/14/6 | Bit 29/21/13/5 | Bit 28/20/12/4 | Bit 27/19/11/3 | Bit 26/18/10/2 | Bit 25/17/9/1 | Bit 24/16/8/0 |
|-----------|-------------------|-------------------|-------------------|-------------------|-------------------|-------------------|------------------|------------------|
| 31:24 | U-0 | U-0 | U-0 | R/W-0 | R/W-0 | R/W-0 | R/W-1 | R/W-1 |
| | — | — | — | ADCEIS<2:0> | | | SELRES<1:0> | |
| 23:16 | U-0 | R/W-0 | R/W-0 | R/W-0 | R/W-0 | R/W-0 | R/W-0 | R/W-0 |
| | — | ADCDIV<6:0> | | | | | | |
| 15:8 | U-0 | U-0 | U-0 | U-0 | U-0 | U-0 | R/W-0 | R/W-0 |
| | — | — | — | — | — | — | SAMC<9:8> | |
| 7:0 | R/W-0 | R/W-0 | R/W-0 | R/W-0 | R/W-0 | R/W-0 | R/W-0 | R/W-0 |
| | SAMC<7:0> | | | | | | | |

Legend:

R = Readable bit W = Writable bit U = Unimplemented bit, read as '0'
 -n = Value at POR '1' = Bit is set '0' = Bit is cleared x = Bit is unknown

bit 31-29 **Unimplemented:** Read as '0'

bit 28-26 **ADCEIS<2:0>:** ADCx Early Interrupt Select bits

111 = The data ready interrupt is generated 8 ADC clocks prior to the end of conversion

110 = The data ready interrupt is generated 7 ADC clocks prior to the end of conversion

•
•
•

001 = The data ready interrupt is generated 2 ADC clocks prior to the end of conversion

000 = The data ready interrupt is generated 1 ADC clock prior to the end of conversion

Note: All options are available when the selected resolution, specified by the SELRES<1:0> bits (ADCxTIME<25:24>), is 12-bit or 10-bit. For a selected resolution of 8-bit, options from '000' to '101' are valid. For a selected resolution of 6-bit, options from '000' to '011' are valid.

bit 25-24 **SELRES<1:0>:** ADCx Resolution Select bits

11 = 12 bits

10 = 10 bits

01 = 8 bits

00 = 6 bits

bit 23 **Unimplemented:** Read as '0'

bit 22-16 **ADCDIV<6:0>:** ADCx Clock Divisor bits

These bits divide the ADC control clock with period TQ to generate the clock for ADCx (TADx).

11111111 = 254 * TQ = TADx

•
•
•

00000111 = 6 * TQ = TADx

00000101 = 4 * TQ = TADx

00000011 = 2 * TQ = TADx

00000000 = Reserved

bit 15-10 **Unimplemented:** Read as '0'

bit 9-0 **SAMC<9:0>:** ADCx Sample Time bits

Where TADx = period of the ADC conversion clock for the dedicated ADC controlled by the ADCDIV<6:0> bits.

1111111111 = 1025 TADx

•
•
•

0000000001 = 3 TADx

0000000000 = 2 TADx

PIC32MZ Embedded Connectivity with Floating Point Unit (EF) Family

REGISTER 28-28: ADCEIEN1: ADC EARLY INTERRUPT ENABLE REGISTER 1

| Bit Range | Bit 31/23/15/7 | Bit 30/22/14/6 | Bit 29/21/13/5 | Bit 28/20/12/4 | Bit 27/19/11/3 | Bit 26/18/10/2 | Bit 25/17/9/1 | Bit 24/16/8/0 |
|-----------|-----------------------|-----------------------|-----------------------|-----------------------|-----------------------|-----------------------|-----------------------|-----------------------|
| 31:24 | R/W-0 | R/W-0 | R/W-0 | R/W-0 | R/W-0 | R/W-0 | R/W-0 | R/W-0 |
| | EIEN31 ⁽¹⁾ | EIEN30 ⁽¹⁾ | EIEN29 ⁽¹⁾ | EIEN28 ⁽¹⁾ | EIEN27 ⁽¹⁾ | EIEN26 ⁽¹⁾ | EIEN25 ⁽¹⁾ | EIEN24 ⁽¹⁾ |
| 23:16 | R/W-0 | R/W-0 | R/W-0 | R/W-0 | R/W-0 | R/W-0 | R/W-0 | R/W-0 |
| | EIEN23 ⁽¹⁾ | EIEN22 ⁽¹⁾ | EIEN21 ⁽¹⁾ | EIEN20 ⁽¹⁾ | EIEN19 ⁽¹⁾ | EIEN18 | EIEN17 | EIEN16 |
| 15:8 | R/W-0 | R/W-0 | R/W-0 | R/W-0 | R/W-0 | R/W-0 | R/W-0 | R/W-0 |
| | EIEN15 | EIEN14 | EIEN13 | EIEN12 | EIEN11 | EIEN10 | EIEN9 | EIEN8 |
| 7:0 | R/W-0 | R/W-0 | R/W-0 | R/W-0 | R/W-0 | R/W-0 | R/W-0 | R/W-0 |
| | EIEN7 | EIEN6 | EIEN5 | EIEN4 | EIEN3 | EIEN2 | EIEN1 | EIEN0 |

Legend:

R = Readable bit W = Writable bit U = Unimplemented bit, read as '0'
 -n = Value at POR '1' = Bit is set '0' = Bit is cleared x = Bit is unknown

bit 31-0 **EIEN31:EIEN0**: Early Interrupt Enable for Analog Input bits

- 1 = Early Interrupts are enabled for the selected analog input. The interrupt is generated after the early interrupt event occurs (indicated by the EIRDYx bit ('x' = 31-0) of the ADCEIEN1 register)
- 0 = Interrupts are disabled

Note 1: This bit is not available on 64-pin devices.

REGISTER 28-29: ADCEIEN2: ADC EARLY INTERRUPT ENABLE REGISTER 2

| Bit Range | Bit 31/23/15/7 | Bit 30/22/14/6 | Bit 29/21/13/5 | Bit 28/20/12/4 | Bit 27/19/11/3 | Bit 26/18/10/2 | Bit 25/17/9/1 | Bit 24/16/8/0 |
|-----------|-----------------------|-----------------------|-----------------------|-----------------------|-----------------------|-----------------------|-----------------------|-----------------------|
| 31:24 | U-0 | U-0 | U-0 | U-0 | U-0 | U-0 | U-0 | U-0 |
| | — | — | — | — | — | — | — | — |
| 23:16 | U-0 | U-0 | U-0 | U-0 | U-0 | U-0 | U-0 | U-0 |
| | — | — | — | — | — | — | — | — |
| 15:8 | U-0 | U-0 | U-0 | R/W-0 | R/W-0 | R/W-0 | R/W-0 | R/W-0 |
| | — | — | — | EIEN44 ⁽²⁾ | EIEN43 ⁽²⁾ | EIEN42 ⁽²⁾ | EIEN41 ⁽²⁾ | EIEN40 ⁽²⁾ |
| 7:0 | R/W-0 | R/W-0 | R/W-0 | R/W-0 | R/W-0 | R/W-0 | R/W-0 | R/W-0 |
| | EIEN39 ⁽²⁾ | EIEN38 ⁽²⁾ | EIEN37 ⁽²⁾ | EIEN36 ⁽²⁾ | EIEN35 ⁽²⁾ | EIEN34 ⁽¹⁾ | EIEN33 ⁽¹⁾ | EIEN32 ⁽¹⁾ |

Legend:

R = Readable bit W = Writable bit U = Unimplemented bit, read as '0'
 -n = Value at POR '1' = Bit is set '0' = Bit is cleared x = Bit is unknown

bit 31-13 **Unimplemented**: Read as '0'

bit 12-0 **EIEN44:EIEN32**: Early Interrupt Enable for Analog Input bits

- 1 = Early Interrupts are enabled for the selected analog input. The interrupt is generated after the early interrupt event occurs (indicated by the EIRDYx bit ('x' = 44-32) of the ADCEIEN2 register)
- 0 = Interrupts are disabled

Note 1: This bit is not available on 64-pin devices.

2: This bit is not available on 64-pin and 100-pin devices.

PIC32MZ Embedded Connectivity with Floating Point Unit (EF) Family

REGISTER 28-30: ADCEIEN1: ADC EARLY INTERRUPT STATUS REGISTER 1

| Bit Range | Bit 31/23/15/7 | Bit 30/22/14/6 | Bit 29/21/13/5 | Bit 28/20/12/4 | Bit 27/19/11/3 | Bit 26/18/10/2 | Bit 25/17/9/1 | Bit 24/16/8/0 |
|-----------|------------------------|------------------------|------------------------|------------------------|------------------------|------------------------|------------------------|------------------------|
| 31:24 | R-0, HS, HC | R-0, HS, HC | R-0, HS, HC | R-0, HS, HC | R-0, HS, HC | R-0, HS, HC | R-0, HS, HC | R-0, HS, HC |
| | EIRDY31 ⁽¹⁾ | EIRDY30 ⁽¹⁾ | EIRDY29 ⁽¹⁾ | EIRDY28 ⁽¹⁾ | EIRDY27 ⁽¹⁾ | EIRDY26 ⁽¹⁾ | EIRDY25 ⁽¹⁾ | EIRDY24 ⁽¹⁾ |
| 23:16 | R-0, HS, HC | R-0, HS, HC | R-0, HS, HC | R-0, HS, HC | R-0, HS, HC | R-0, HS, HC | R-0, HS, HC | R-0, HS, HC |
| | EIRDY23 ⁽¹⁾ | EIRDY22 ⁽¹⁾ | EIRDY21 ⁽¹⁾ | EIRDY20 ⁽¹⁾ | EIRDY19 ⁽¹⁾ | EIRDY18 | EIRDY17 | EIRDY16 |
| 15:8 | R-0, HS, HC | R-0, HS, HC | R-0, HS, HC | R-0, HS, HC | R-0, HS, HC | R-0, HS, HC | R-0, HS, HC | R-0, HS, HC |
| | EIRDY15 | EIRDY14 | EIRDY13 | EIRDY12 | EIRDY11 | EIRDY10 | EIRDY9 | EIRDY8 |
| 7:0 | R-0, HS, HC | R-0, HS, HC | R-0, HS, HC | R-0, HS, HC | R-0, HS, HC | R-0, HS, HC | R-0, HS, HC | R-0, HS, HC |
| | EIRDY7 | EIRDY6 | EIRDY5 | EIRDY4 | EIRDY3 | EIRDY2 | EIRDY1 | EIRDY0 |

| | | |
|-------------------|-------------------|--|
| Legend: | HS = Hardware Set | HC = Hardware Cleared |
| R = Readable bit | W = Writable bit | U = Unimplemented bit, read as '0' |
| -n = Value at POR | '1' = Bit is set | '0' = Bit is cleared x = Bit is unknown |

bit 31-0 **EIRDY31:EIRDY0**: Early Interrupt for Corresponding Analog Input Ready bits

1 = This bit is set when the early interrupt event occurs for the specified analog input. An interrupt will be generated if early interrupts are enabled in the ADCEIEN1 register. For the Class 1 analog inputs, this bit will set as per the configuration of the ADCEIS<2:0> bits in the ADCxTIME register. For the shared ADC module, this bit will be set as per the configuration of the ADCEIS<2:0> bits in the ADCCON2 register.

0 = Interrupts are disabled

Note 1: This bit is not available on 64-pin devices.

PIC32MZ Embedded Connectivity with Floating Point Unit (EF) Family

REGISTER 28-31: ADCEI2STAT2: ADC EARLY INTERRUPT STATUS REGISTER 2

| Bit Range | Bit 31/23/15/7 | Bit 30/22/14/6 | Bit 29/21/13/5 | Bit 28/20/12/4 | Bit 27/19/11/3 | Bit 26/18/10/2 | Bit 25/17/9/1 | Bit 24/16/8/0 |
|-----------|------------------------|------------------------|------------------------|------------------------|------------------------|------------------------|------------------------|------------------------|
| 31:24 | U-0 | U-0 | U-0 | U-0 | U-0 | U-0 | U-0 | U-0 |
| | — | — | — | — | — | — | — | — |
| 23:16 | U-0 | U-0 | U-0 | U-0 | U-0 | U-0 | U-0 | U-0 |
| | — | — | — | — | — | — | — | — |
| 15:8 | U-0 | U-0 | U-0 | R-0, HS, HC | R-0, HS, HC | R-0, HS, HC | R-0, HS, HC | R-0, HS, HC |
| | — | — | — | EIRDY44 ⁽²⁾ | EIRDY43 ⁽²⁾ | EIRDY42 ⁽²⁾ | EIRDY41 ⁽²⁾ | EIRDY40 ⁽²⁾ |
| 7:0 | R-0, HS, HC | R-0, HS, HC | R-0, HS, HC | R-0, HS, HC | R-0, HS, HC | R-0, HS, HC | R-0, HS, HC | R-0, HS, HC |
| | EIRDY39 ⁽²⁾ | EIRDY38 ⁽²⁾ | EIRDY37 ⁽²⁾ | EIRDY36 ⁽²⁾ | EIRDY35 ⁽²⁾ | EIRDY34 ⁽¹⁾ | EIRDY33 ⁽¹⁾ | EIRDY32 ⁽¹⁾ |

| | | |
|-------------------|-------------------|--|
| Legend: | HS = Hardware Set | HC = Hardware Cleared |
| R = Readable bit | W = Writable bit | U = Unimplemented bit, read as '0' |
| -n = Value at POR | '1' = Bit is set | '0' = Bit is cleared x = Bit is unknown |

bit 31-13 **Unimplemented:** Read as '0'

bit 31-0 **EIRDY44:EIRDY32:** Early Interrupt for Corresponding Analog Input Ready bits

1 = This bit is set when the early interrupt event occurs for the specified analog input. An interrupt will be generated if early interrupts are enabled in the ADCEIEN2 register. For the Class 1 analog inputs, this bit will set as per the configuration of the ADCEIS<2:0> bits in the ADCxTIME register. For the shared ADC module, this bit will be set as per the configuration of the ADCEIS<2:0> bits in the ADCCON2 register.

0 = Interrupts are disabled

Note 1: This bit is not available on 64-pin devices.

2: This bit is not available on 64-pin and 100-pin devices.

PIC32MZ Embedded Connectivity with Floating Point Unit (EF) Family

REGISTER 28-32: ADCANCON: ADC ANALOG WARM-UP CONTROL REGISTER

| Bit Range | Bit 31/23/15/7 | Bit 30/22/14/6 | Bit 29/21/13/5 | Bit 28/20/12/4 | Bit 27/19/11/3 | Bit 26/18/10/2 | Bit 25/17/9/1 | Bit 24/16/8/0 |
|-----------|-------------------|-------------------|-------------------|-------------------|-------------------|-------------------|------------------|------------------|
| 31:24 | U-0 | U-0 | U-0 | U-0 | R/W-0 | R/W-0 | R/W-0 | R/W-0 |
| | — | — | — | — | WKUPCLKCNT<3:0> | | | |
| 23:16 | R/W-0 | U-0 | U-0 | R/W-0 | R/W-0 | R/W-0 | R/W-0 | R/W-0 |
| | WKIEN7 | — | — | WKIEN4 | WKIEN3 | WKIEN2 | WKIEN1 | WKIEN0 |
| 15:8 | R-0, HS, HC | U-0 | U-0 | R-0, HS, HC | R-0, HS, HC | R-0, HS, HC | R-0, HS, HC | R-0, HS, HC |
| | WKRDY7 | — | — | WKRDY4 | WKRDY3 | WKRDY2 | WKRDY1 | WKRDY0 |
| 7:0 | R/W-0 | U-0 | U-0 | R/W-0 | R/W-0 | R/W-0 | R/W-0 | R/W-0 |
| | ANEN7 | — | — | ANEN4 | ANEN3 | ANEN2 | ANEN1 | ANEN0 |

| | | |
|-------------------|-------------------|--|
| Legend: | HS = Hardware Set | HC = Hardware Cleared |
| R = Readable bit | W = Writable bit | U = Unimplemented bit, read as '0' |
| -n = Value at POR | '1' = Bit is set | '0' = Bit is cleared x = Bit is unknown |

bit 31-28 **Unimplemented:** Read as '0'

bit 27-24 **WKUPCLKCNT<3:0>:** Wake-up Clock Count bits

These bits represent the number of ADC clocks required to warm-up the ADC module before it can perform conversion. Although the clocks are specific to each ADC, the WKUPCLKCNT bit is common to all ADC modules.

$$1111 = 2^{15} = 32,768 \text{ clocks}$$

-
-
-

$$0110 = 2^6 = 64 \text{ clocks}$$

$$0101 = 2^5 = 32 \text{ clocks}$$

$$0100 = 2^4 = 16 \text{ clocks}$$

$$0011 = 2^4 = 16 \text{ clocks}$$

$$0010 = 2^4 = 16 \text{ clocks}$$

$$0001 = 2^4 = 16 \text{ clocks}$$

$$0000 = 2^4 = 16 \text{ clocks}$$

bit 23 **WKIEN7:** Shared ADC (ADC7) Wake-up Interrupt Enable bit

1 = Enable interrupt and generate interrupt when the WKRDY7 status bit is set

0 = Disable interrupt

bit 22-21 **Unimplemented:** Read as '0'

bit 20-16 **WKIEN4:WKIEN0:** ADC4-ADC0 Wake-up Interrupt Enable bit

1 = Enable interrupt and generate interrupt when the WKRDYx status bit is set

0 = Disable interrupt

bit 15 **WKRDY7:** Shared ADC (ADC7) Wake-up Status bit

1 = ADC7 Analog and Bias circuitry ready after the wake-up count number $2^{WKUPEXP}$ clocks after setting ANEN7 to '1'

0 = ADC7 Analog and Bias circuitry is not ready

Note: This bit is cleared by hardware when the ANEN7 bit is cleared

bit 14-13 **Unimplemented:** Read as '0'

bit 12-8 **WKRDY4:WKRDY0:** ADC4-ADC0 Wake-up Status bit

1 = ADCx Analog and Bias circuitry ready after the wake-up count number $2^{WKUPEXP}$ clocks after setting ANENx to '1'

0 = ADCx Analog and Bias circuitry is not ready

Note: These bits are cleared by hardware when the ANENx bit is cleared

PIC32MZ Embedded Connectivity with Floating Point Unit (EF) Family

REGISTER 28-32: ADCANCON: ADC ANALOG WARM-UP CONTROL REGISTER (CONTINUED)

- bit 7 **ANEN7:** Shared ADC (ADC7) Analog and Bias Circuitry Enable bit
1 = Analog and bias circuitry enabled. Once the analog and bias circuit is enabled, the ADC module needs a warm-up time, as defined by the WKUPCLKCNT<3:0> bits.
0 = Analog and bias circuitry disabled
- bit 5-6 **Unimplemented:** Read as '0'
- bit 4-0 **ANEN4:ANEN0:** ADC4-ADC0 Analog and Bias Circuitry Enable bits
1 = Analog and bias circuitry enabled. Once the analog and bias circuit is enabled, the ADC module needs a warm-up time, as defined by the WKUPCLKCNT<3:0> bits.
0 = Analog and bias circuitry disabled

PIC32MZ Embedded Connectivity with Floating Point Unit (EF) Family

REGISTER 28-33: ADC_xCFG: ADC_x CONFIGURATION REGISTER 'x' ('x' = 1 THROUGH 4 AND 7)

| Bit Range | Bit 31/23/15/7 | Bit 30/22/14/6 | Bit 29/21/13/5 | Bit 28/20/12/4 | Bit 27/19/11/3 | Bit 26/18/10/2 | Bit 25/17/9/1 | Bit 24/16/8/0 |
|---------------|-------------------|-------------------|-------------------|-------------------|-------------------|-------------------|------------------|------------------|
| 31:24 | R/W-0 | R/W-0 | R/W-0 | R/W-0 | R/W-0 | R/W-0 | R/W-0 | R/W-0 |
| ADCCFG<31:24> | | | | | | | | |
| 23:16 | R/W-0 | R/W-0 | R/W-0 | R/W-0 | R/W-0 | R/W-0 | R/W-0 | R/W-0 |
| ADCCFG<23:16> | | | | | | | | |
| 15:8 | R/W-0 | R/W-0 | R/W-0 | R/W-0 | R/W-0 | R/W-0 | R/W-0 | R/W-0 |
| ADCCFG<15:8> | | | | | | | | |
| 7:0 | R/W-0 | R/W-0 | R/W-0 | R/W-0 | R/W-0 | R/W-0 | R/W-0 | R/W-0 |
| ADCCFG<7:0> | | | | | | | | |

Legend:

R = Readable bit W = Writable bit U = Unimplemented bit, read as '0'
 -n = Value at POR '1' = Bit is set '0' = Bit is cleared x = Bit is unknown

bit 31-0 **ADCCFG<31:0>**: ADC Module Configuration Data bits

Note: These bits can only change when the applicable ANEN_x bit in the ADCANCON register is cleared.

PIC32MZ Embedded Connectivity with Floating Point Unit (EF) Family

REGISTER 28-34: ADCSYSCFG1: ADC SYSTEM CONFIGURATION REGISTER 1

| Bit Range | Bit 31/23/15/7 | Bit 30/22/14/6 | Bit 29/21/13/5 | Bit 28/20/12/4 | Bit 27/19/11/3 | Bit 26/18/10/2 | Bit 25/17/9/1 | Bit 24/16/8/0 |
|-----------|-------------------|-------------------|-------------------|-------------------|-------------------|-------------------|------------------|------------------|
| 31:24 | R-y | R-y | R-y | R-y | R-y | R-y | R-y | R-y |
| | AN<31:23> | | | | | | | |
| 23:16 | R-y | R-y | R-y | R-y | R-y | R-1 | R-1 | R-1 |
| | AN<23:16> | | | | | | | |
| 15:8 | R-1 | R-1 | R-1 | R-1 | R-1 | R-1 | R-1 | R-1 |
| | AN<15:8> | | | | | | | |
| 7:0 | R-1 | R-1 | R-1 | R-1 | R-1 | R-1 | R-1 | R-1 |
| | AN<7:0> | | | | | | | |

| | |
|-------------------|--|
| Legend: | y = POR value is determined by the specific device |
| R = Readable bit | W = Writable bit |
| -n = Value at POR | '1' = Bit is set |
| | U = Unimplemented bit, read as '0' |
| | '0' = Bit is cleared |
| | x = Bit is unknown |

bit 31-0 **AN<31:0>**: ADC Analog Input bits

These bits reflect the system configuration and are updated during boot-up time. By reading these read-only bits, the user application can determine whether or not an analog input in the device is available.

AN<31:0>: Reflects the presence or absence of the respective analog input (AN31-AN0).

REGISTER 28-35: ADCSYSCFG2: ADC SYSTEM CONFIGURATION REGISTER 2

| Bit Range | Bit 31/23/15/7 | Bit 30/22/14/6 | Bit 29/21/13/5 | Bit 28/20/12/4 | Bit 27/19/11/3 | Bit 26/18/10/2 | Bit 25/17/9/1 | Bit 24/16/8/0 |
|-----------|-------------------|-------------------|-------------------|-------------------|-------------------|-------------------|------------------|------------------|
| 31:24 | U-0 | U-0 | U-0 | U-0 | U-0 | U-0 | U-0 | U-0 |
| | — | — | — | — | — | — | — | — |
| 23:16 | U-0 | U-0 | U-0 | U-0 | U-0 | U-0 | U-0 | U-0 |
| | — | — | — | — | — | — | — | — |
| 15:8 | U-0 | U-0 | U-0 | R-1 | R-1 | R-y | R-y | R-y |
| | — | — | — | AN<44:40> | | | | |
| 7:0 | R-y | R-y | R-y | R-y | R-y | R-y | R-y | R-y |
| | AN<39:32> | | | | | | | |

| | |
|-------------------|--|
| Legend: | y = POR value is determined by the specific device |
| R = Readable bit | W = Writable bit |
| -n = Value at POR | '1' = Bit is set |
| | U = Unimplemented bit, read as '0' |
| | '0' = Bit is cleared |
| | x = Bit is unknown |

bit 31-13 **Unimplemented:** Read as '0'

bit 12-0 **AN<44:32>**: ADC Analog Input bits

These bits reflect the system configuration and are updated during boot-up time. By reading these read-only bits, the user application can determine whether or not an analog input in the device is available.

AN<63:32>: Reflects the presence or absence of the respective analog input (AN63-AN32).

PIC32MZ Embedded Connectivity with Floating Point Unit (EF) Family

NOTES:

29.0 CONTROLLER AREA NETWORK (CAN)

Note: This data sheet summarizes the features of the PIC32MZ EF family of devices. It is not intended to be a comprehensive reference source. To complement the information in this data sheet, refer to **Section 34. "Controller Area Network (CAN)"** (DS60001154) in the *"PIC32 Family Reference Manual"*, which is available from the Microchip web site (www.microchip.com/PIC32).

The Controller Area Network (CAN) module supports the following key features:

- Standards Compliance:
 - Full CAN 2.0B compliance
 - Programmable bit rate up to 1 Mbps
- Message Reception and Transmission:
 - 32 message FIFOs
 - Each FIFO can have up to 32 messages for a total of 1024 messages

- FIFO can be a transmit message FIFO or a receive message FIFO
- User-defined priority levels for message FIFOs used for transmission
- 32 acceptance filters for message filtering
- Four acceptance filter mask registers for message filtering
- Automatic response to remote transmit request
- DeviceNet™ addressing support
- Additional Features:
 - Loopback, Listen All Messages and Listen Only modes for self-test, system diagnostics and bus monitoring
 - Low-power operating modes
 - CAN module is a bus master on the PIC32 System Bus
 - Use of DMA is not required
 - Dedicated time-stamp timer
 - Dedicated DMA channels
 - Data-only Message Reception mode

Figure 29-1 illustrates the general structure of the CAN module.

FIGURE 29-1: PIC32 CAN MODULE BLOCK DIAGRAM

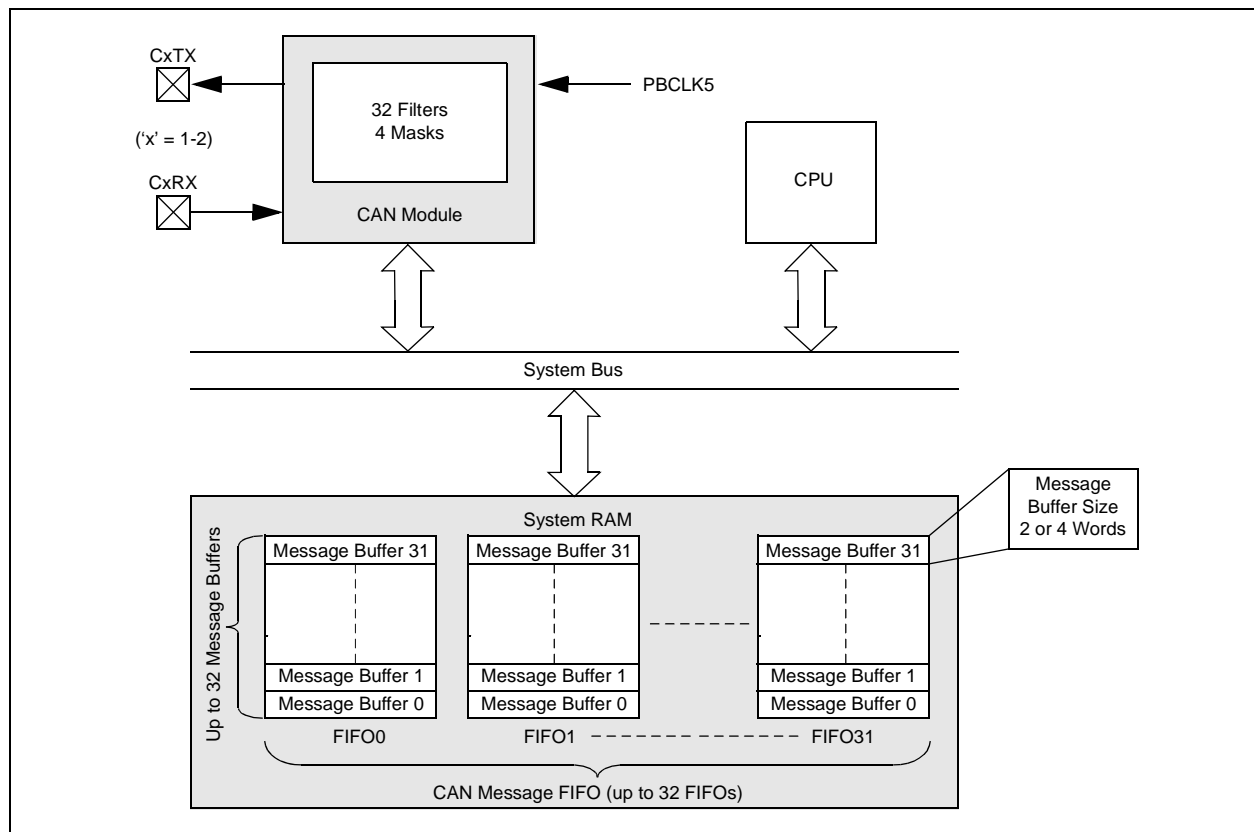

29.1 CAN Control Registers

Note: The 'i' shown in register names denotes CAN1 or CAN2.

TABLE 29-1: CAN1 REGISTER SUMMARY FOR PIC32MZXXXECF AND PIC32MZXXXECH DEVICES

| Virtual Address (BF88_#) | Register Name(1) | Bit Range | Bits | | | | | | | | | | | | | | | | All Resets | |
|--------------------------|------------------|-----------|----------------|-------------|-------------|-------------|-------------|------------|--------------|----------|------------|-------------|----------|-------------|----------|-------------|----------|----------|------------|------|
| | | | 31/15 | 30/14 | 29/13 | 28/12 | 27/11 | 26/10 | 25/9 | 24/8 | 23/7 | 22/6 | 21/5 | 20/4 | 19/3 | 18/2 | 17/1 | 16/0 | | |
| 0000 | C1CON | 31:16 | — | — | — | — | ABAT | REQOP<2:0> | | | OPMOD<2:0> | | | CANCAP | — | — | — | — | 0480 | |
| | | 15:0 | ON | — | SIDLE | — | CANBUSY | — | — | — | — | — | — | DNCNT<4:0> | | | | | 0000 | |
| 0010 | C1CFG | 31:16 | — | — | — | — | — | — | — | — | — | — | — | — | — | SEG2PH<2:0> | | | | 0000 |
| | | 15:0 | SEG2PHTS | SAM | SEG1PH<2:0> | | | PRSEG<2:0> | | | SJW<1:0> | | BRP<5:0> | | | | | 0000 | | |
| 0020 | C1INT | 31:16 | IVRIE | WAKIE | CERRIE | SERRIE | RBOVIE | — | — | — | — | — | — | — | — | MODIE | CTMRIE | RBIE | TBIE | 0000 |
| | | 15:0 | IVRIF | WAKIF | CERRIF | SERRIF | RBOVIF | — | — | — | — | — | — | — | — | MODIF | CTMRIF | RBIF | TBIF | 0000 |
| 0030 | C1VEC | 31:16 | — | — | — | — | — | — | — | — | — | — | — | — | — | — | — | — | — | 0000 |
| | | 15:0 | — | — | — | FILHIT<4:0> | | | | — | ICODE<6:0> | | | | | | 0040 | | | |
| 0040 | C1TREC | 31:16 | — | — | — | — | — | — | — | — | — | — | — | TXBO | TXBP | RXPB | TXWARN | RXWARN | EWARN | 0000 |
| | | 15:0 | TERRCNT<7:0> | | | | | | RERRCNT<7:0> | | | | | | | | | | 0000 | |
| 0050 | C1FSTAT | 31:16 | FIFOIP31 | FIFOIP30 | FIFOIP29 | FIFOIP28 | FIFOIP27 | FIFOIP26 | FIFOIP25 | FIFOIP24 | FIFOIP23 | FIFOIP22 | FIFOIP21 | FIFOIP20 | FIFOIP19 | FIFOIP18 | FIFOIP17 | FIFOIP16 | | 0000 |
| | | 15:0 | FIFOIP15 | FIFOIP14 | FIFOIP13 | FIFOIP12 | FIFOIP11 | FIFOIP10 | FIFOIP9 | FIFOIP8 | FIFOIP7 | FIFOIP6 | FIFOIP5 | FIFOIP4 | FIFOIP3 | FIFOIP2 | FIFOIP1 | FIFOIP0 | | 0000 |
| 0060 | C1RXOVF | 31:16 | RXOVF31 | RXOVF30 | RXOVF29 | RXOVF28 | RXOVF27 | RXOVF26 | RXOVF25 | RXOVF24 | RXOVF23 | RXOVF22 | RXOVF21 | RXOVF20 | RXOVF19 | RXOVF18 | RXOVF17 | RXOVF16 | | 0000 |
| | | 15:0 | RXOVF15 | RXOVF14 | RXOVF13 | RXOVF12 | RXOVF11 | RXOVF10 | RXOVF9 | RXOVF8 | RXOVF7 | RXOVF6 | RXOVF5 | RXOVF4 | RXOVF3 | RXOVF2 | RXOVF1 | RXOVF0 | | 0000 |
| 0070 | C1TMR | 31:16 | CANTS<15:0> | | | | | | | | | | | | | | | | 0000 | |
| | | 15:0 | CANTSPRE<15:0> | | | | | | | | | | | | | | | | 0000 | |
| 0080 | C1RXM0 | 31:16 | SID<10:0> | | | | | | | | | | — | MIDE | — | EID<17:16> | | | xxxx | |
| | | 15:0 | EID<15:0> | | | | | | | | | | | | | | | | xxxx | |
| 0090 | C1RXM1 | 31:16 | SID<10:0> | | | | | | | | | | — | MIDE | — | EID<17:16> | | | xxxx | |
| | | 15:0 | EID<15:0> | | | | | | | | | | | | | | | | xxxx | |
| 00A0 | C1RXM2 | 31:16 | SID<10:0> | | | | | | | | | | — | MIDE | — | EID<17:16> | | | xxxx | |
| | | 15:0 | EID<15:0> | | | | | | | | | | | | | | | | xxxx | |
| 00B0 | C1RXM3 | 31:16 | SID<10:0> | | | | | | | | | | — | MIDE | — | EID<17:16> | | | xxxx | |
| | | 15:0 | EID<15:0> | | | | | | | | | | | | | | | | xxxx | |
| 00C0 | C1FLTCON0 | 31:16 | FLTEN3 | MSEL3<1:0> | | | FSEL3<4:0> | | | | FLTEN2 | MSEL2<1:0> | | FSEL2<4:0> | | | | 0000 | | |
| | | 15:0 | FLTEN1 | MSEL1<1:0> | | | FSEL1<4:0> | | | | FLTEN0 | MSEL0<1:0> | | FSEL0<4:0> | | | | 0000 | | |
| 00D0 | C1FLTCON1 | 31:16 | FLTEN7 | MSEL7<1:0> | | | FSEL7<4:0> | | | | FLTEN6 | MSEL6<1:0> | | FSEL6<4:0> | | | | 0000 | | |
| | | 15:0 | FLTEN5 | MSEL5<1:0> | | | FSEL5<4:0> | | | | FLTEN4 | MSEL4<1:0> | | FSEL4<4:0> | | | | 0000 | | |
| 00E0 | C1FLTCON2 | 31:16 | FLTEN11 | MSEL11<1:0> | | | FSEL11<4:0> | | | | FLTEN10 | MSEL10<1:0> | | FSEL10<4:0> | | | | 0000 | | |
| | | 15:0 | FLTEN9 | MSEL9<1:0> | | | FSEL9<4:0> | | | | FLTEN8 | MSEL8<1:0> | | FSEL8<4:0> | | | | 0000 | | |

Legend: x = unknown value on Reset; — = unimplemented, read as '0'. Reset values are shown in hexadecimal.

Note 1: All registers in this table have corresponding CLR, SET and INV registers at their virtual addresses, plus offsets of 0x4, 0x8 and 0xC, respectively. See [Section 12.3 "CLR, SET, and INV Registers"](#) for more information.

TABLE 29-1: CAN1 REGISTER SUMMARY FOR PIC32MZXXXECF AND PIC32MZXXXECH DEVICES (CONTINUED)

| Virtual Address (BF88.#) | Register Name(1) | Bit Range | Bits | | | | | | | | | | | | | | | All Resets | |
|-----------------------------|--|-----------|----------------|-------------|-------------|-------|-------|-----------|----------|-----------|-------------|--------|--------|---------------|-------------|----------|------------|----------------|------|
| | | | 31/15 | 30/14 | 29/13 | 28/12 | 27/11 | 26/10 | 25/9 | 24/8 | 23/7 | 22/6 | 21/5 | 20/4 | 19/3 | 18/2 | 17/1 | | 16/0 |
| 00F0 | C1FLTCO3 | 31:16 | FLTEN15 | MSEL15<1:0> | FSEL15<4:0> | | | | | FLTEN14 | MSEL14<1:0> | | | | FSEL14<4:0> | | | | 0000 |
| | | 15:0 | FLTEN13 | MSEL13<1:0> | FSEL13<4:0> | | | | | FLTEN12 | MSEL12<1:0> | | | | FSEL12<4:0> | | | | 0000 |
| 0100 | C1FLTCO4 | 31:16 | FLTEN19 | MSEL19<1:0> | FSEL19<4:0> | | | | | FLTEN18 | MSEL18<1:0> | | | | FSEL18<4:0> | | | | 0000 |
| | | 15:0 | FLTEN17 | MSEL17<1:0> | FSEL17<4:0> | | | | | FLTEN16 | MSEL16<1:0> | | | | FSEL16<4:0> | | | | 0000 |
| 0110 | C1FLTCO5 | 31:16 | FLTEN23 | MSEL23<1:0> | FSEL23<4:0> | | | | | FLTEN22 | MSEL22<1:0> | | | | FSEL22<4:0> | | | | 0000 |
| | | 15:0 | FLTEN21 | MSEL21<1:0> | FSEL21<4:0> | | | | | FLTEN20 | MSEL20<1:0> | | | | FSEL20<4:0> | | | | 0000 |
| 0120 | C1FLTCO6 | 31:16 | FLTEN27 | MSEL27<1:0> | FSEL27<4:0> | | | | | FLTEN26 | MSEL26<1:0> | | | | FSEL26<4:0> | | | | 0000 |
| | | 15:0 | FLTEN25 | MSEL25<1:0> | FSEL25<4:0> | | | | | FLTEN24 | MSEL24<1:0> | | | | FSEL24<4:0> | | | | 0000 |
| 0130 | C1FLTCO7 | 31:16 | FLTEN31 | MSEL31<1:0> | FSEL31<4:0> | | | | | FLTEN30 | MSEL30<1:0> | | | | FSEL30<4:0> | | | | 0000 |
| | | 15:0 | FLTEN29 | MSEL29<1:0> | FSEL29<4:0> | | | | | FLTEN28 | MSEL28<1:0> | | | | FSEL28<4:0> | | | | 0000 |
| 0140- 0330 | C1RXFn (n = 0-31) | 31:16 | SID<10:0> | | | | | | | | | | | — | EXID | — | EID<17:16> | | xxxx |
| | | 15:0 | EID<15:0> | | | | | | | | | | | | | | | xxxx | |
| 0340 | C1FIFOBA | 31:16 | C1FIFOBA<31:0> | | | | | | | | | | | | | | | 0000 | |
| | | 15:0 | | | | | | | | | | | | | | | | 0000 | |
| 0350 | C1FIFOCONn (n = 0) | 31:16 | — | — | — | — | — | — | — | — | — | — | — | FSIZE<4:0> | | | | | 0000 |
| | | 15:0 | — | FRESET | UINC | DONLY | — | — | — | — | TXEN | TXABAT | TXLARB | TXERR | TXREQ | RTREN | TXPRI<1:0> | | 0000 |
| 0360 | C1FIFOINTn (n = 0) | 31:16 | — | — | — | — | — | TXNFULLIE | TXHALFIE | TXEMPTYIE | — | — | — | — | RXOVFLIE | RXFULLIE | RXHALFIE | RXN EMPTYIE | 0000 |
| | | 15:0 | — | — | — | — | — | TXNFULLIF | TXHALFIF | TXEMPTYIF | — | — | — | — | RXOVFLIF | RXFULLIF | RXHALFIF | RXN EMPTYIF | 0000 |
| 0370 | C1FIFOUAn (n = 0) | 31:16 | C1FIFOUA<31:0> | | | | | | | | | | | | | | | 0000 | |
| | | 15:0 | | | | | | | | | | | | | | | | 0000 | |
| 0380 | C1FIFOCIn (n = 0) | 31:16 | — | — | — | — | — | — | — | — | — | — | — | — | — | — | — | — | 0000 |
| | | 15:0 | — | — | — | — | — | — | — | — | — | — | — | C1FIFOCI<4:0> | | | | | 0000 |
| 0390- 0B40 | C1FIFOCONn C1FIFOINTn C1FIFOUAn C1FIFOCIn (n = 1-31) | 31:16 | FSIZE<4:0> | | | | | | | | | | | | | | | 0000 | |
| | | 15:0 | — | FRESET | UINC | DONLY | — | — | — | — | TXEN | TXABAT | TXLARB | TXERR | TXREQ | RTREN | TXPRI<1:0> | | 0000 |
| | | 31:16 | — | — | — | — | — | TXNFULLIE | TXHALFIE | TXEMPTYIE | — | — | — | — | RXOVFLIE | RXFULLIE | RXHALFIE | RXN EMPTYIE | 0000 |
| | | 15:0 | — | — | — | — | — | TXNFULLIF | TXHALFIF | TXEMPTYIF | — | — | — | — | RXOVFLIF | RXFULLIF | RXHALFIF | RXN EMPTYIF | 0000 |
| | | 31:16 | C1FIFOUA<31:0> | | | | | | | | | | | | | | | 0000 | |
| | | 15:0 | | | | | | | | | | | | | | | | 0000 | |
| | | 31:16 | — | — | — | — | — | — | — | — | — | — | — | — | — | — | — | — | 0000 |
| | | 15:0 | — | — | — | — | — | — | — | — | — | — | — | C1FIFOCI<4:0> | | | | | 0000 |

Legend: x = unknown value on Reset; — = unimplemented, read as '0'. Reset values are shown in hexadecimal.

Note 1: All registers in this table have corresponding CLR, SET and INV registers at their virtual addresses, plus offsets of 0x4, 0x8 and 0xC, respectively. See [Section 12.3 "CLR, SET, and INV Registers"](#) for more information.

TABLE 29-2: CAN2 REGISTER SUMMARY FOR PIC32MZXXXECF AND PIC32MZXXXECH DEVICES

| Virtual Address (BF88_#) | Register Name ⁽¹⁾ | Bit Range | Bits | | | | | | | | | | | | | | | | All Resets | | |
|--------------------------|------------------------------|-----------|----------------|-------------|-------------|-------------|-------------|------------|----------|--------------|------------|-------------|----------|----------|-------------|------------|----------|-------------|------------|------|------|
| | | | 31/15 | 30/14 | 29/13 | 28/12 | 27/11 | 26/10 | 25/9 | 24/8 | 23/7 | 22/6 | 21/5 | 20/4 | 19/3 | 18/2 | 17/1 | 16/0 | | | |
| 1000 | C2CON | 31:16 | — | — | — | — | ABAT | REQOP<2:0> | | | | OPMOD<2:0> | | | CANCAP | — | — | — | — | 0480 | |
| | | 15:0 | ON | — | SIDLE | — | CANBUSY | — | — | — | — | — | — | — | DNCNT<4:0> | | | | 0000 | | |
| 1010 | C2CFG | 31:16 | — | — | — | — | — | — | — | — | — | — | — | WAKFIL | — | — | — | SEG2PH<2:0> | | 0000 | |
| | | 15:0 | SEG2PHTS | SAM | SEG1PH<2:0> | | | PRSEG<2:0> | | | SJW<1:0> | | BRP<5:0> | | | | | 0000 | | | |
| 1020 | C2INT | 31:16 | IVRIE | WAKIE | CERRIE | SERRIE | RBOVIE | — | — | — | — | — | — | MODIE | CTMRIE | RBIE | TBIE | | | 0000 | |
| | | 15:0 | IVRIF | WAKIF | CERRIF | SERRIF | RBOVIF | — | — | — | — | — | — | MODIF | CTMRIF | RBIF | TBIF | | | 0000 | |
| 1030 | C2VEC | 31:16 | — | — | — | — | — | — | — | — | — | — | — | — | — | — | — | | | 0000 | |
| | | 15:0 | — | — | — | FILHIT<4:0> | | | | — | ICODE<6:0> | | | | | | 0040 | | | | |
| 1040 | C2TREC | 31:16 | — | — | — | — | — | — | — | — | — | — | — | TXBO | TXBP | RXBP | TXWARN | RXWARN | EWARN | 0000 | |
| | | 15:0 | TERRCNT<7:0> | | | | | | | RERRCNT<7:0> | | | | | | | | | 0000 | | |
| 1050 | C2FSTAT | 31:16 | FIFOIP31 | FIFOIP30 | FIFOIP29 | FIFOIP28 | FIFOIP27 | FIFOIP26 | FIFOIP25 | FIFOIP24 | FIFOIP23 | FIFOIP22 | FIFOIP21 | FIFOIP20 | FIFOIP19 | FIFOIP18 | FIFOIP17 | FIFOIP16 | | | 0000 |
| | | 15:0 | FIFOIP15 | FIFOIP14 | FIFOIP13 | FIFOIP12 | FIFOIP11 | FIFOIP10 | FIFOIP9 | FIFOIP8 | FIFOIP7 | FIFOIP6 | FIFOIP5 | FIFOIP4 | FIFOIP3 | FIFOIP2 | FIFOIP1 | FIFOIP0 | | | 0000 |
| 1060 | C2RXOVF | 31:16 | RXOVF31 | RXOVF30 | RXOVF29 | RXOVF28 | RXOVF27 | RXOVF26 | RXOVF25 | RXOVF24 | RXOVF23 | RXOVF22 | RXOVF21 | RXOVF20 | RXOVF19 | RXOVF18 | RXOVF17 | RXOVF16 | | | 0000 |
| | | 15:0 | RXOVF15 | RXOVF14 | RXOVF13 | RXOVF12 | RXOVF11 | RXOVF10 | RXOVF9 | RXOVF8 | RXOVF7 | RXOVF6 | RXOVF5 | RXOVF4 | RXOVF3 | RXOVF2 | RXOVF1 | RXOVF0 | | | 0000 |
| 1070 | C2TMR | 31:16 | CANTS<15:0> | | | | | | | | | | | | | | | | 0000 | | |
| | | 15:0 | CANTSPRE<15:0> | | | | | | | | | | | | | | | | 0000 | | |
| 1080 | C2RXM0 | 31:16 | SID<10:0> | | | | | | | | | | — | MIDE | — | EID<17:16> | | | xxxxx | | |
| | | 15:0 | EID<15:0> | | | | | | | | | | | | | | | | xxxxx | | |
| 10A0 | C2RXM1 | 31:16 | SID<10:0> | | | | | | | | | | — | MIDE | — | EID<17:16> | | | xxxxx | | |
| | | 15:0 | EID<15:0> | | | | | | | | | | | | | | | | xxxxx | | |
| 10B0 | C2RXM2 | 31:16 | SID<10:0> | | | | | | | | | | — | MIDE | — | EID<17:16> | | | xxxxx | | |
| | | 15:0 | EID<15:0> | | | | | | | | | | | | | | | | xxxxx | | |
| 10B0 | C2RXM3 | 31:16 | SID<10:0> | | | | | | | | | | — | MIDE | — | EID<17:16> | | | xxxxx | | |
| | | 15:0 | EID<15:0> | | | | | | | | | | | | | | | | xxxxx | | |
| 1010 | C2FLTCON0 | 31:16 | FLTEN3 | MSEL3<1:0> | | | FSEL3<4:0> | | | | FLTEN2 | MSEL2<1:0> | | | FSEL2<4:0> | | | | 0000 | | |
| | | 15:0 | FLTEN1 | MSEL1<1:0> | | | FSEL1<4:0> | | | | FLTEN0 | MSEL0<1:0> | | | FSEL0<4:0> | | | | 0000 | | |
| 10D0 | C2FLTCON1 | 31:16 | FLTEN7 | MSEL7<1:0> | | | FSEL7<4:0> | | | | FLTEN6 | MSEL6<1:0> | | | FSEL6<4:0> | | | | 0000 | | |
| | | 15:0 | FLTEN5 | MSEL5<1:0> | | | FSEL5<4:0> | | | | FLTEN4 | MSEL4<1:0> | | | FSEL4<4:0> | | | | 0000 | | |
| 10E0 | C2FLTCON2 | 31:16 | FLTEN11 | MSEL11<1:0> | | | FSEL11<4:0> | | | | FLTEN10 | MSEL10<1:0> | | | FSEL10<4:0> | | | | 0000 | | |
| | | 15:0 | FLTEN9 | MSEL9<1:0> | | | FSEL9<4:0> | | | | FLTEN8 | MSEL8<1:0> | | | FSEL8<4:0> | | | | 0000 | | |
| 10F0 | C2FLTCON3 | 31:16 | FLTEN15 | MSEL15<1:0> | | | FSEL15<4:0> | | | | FLTEN14 | MSEL14<1:0> | | | FSEL14<4:0> | | | | 0000 | | |
| | | 15:0 | FLTEN13 | MSEL13<1:0> | | | FSEL13<4:0> | | | | FLTEN12 | MSEL12<1:0> | | | FSEL12<4:0> | | | | 0000 | | |

Legend: x = unknown value on Reset; — = unimplemented, read as '0'. Reset values are shown in hexadecimal.
Note 1: All registers in this table have corresponding CLR, SET and INV registers at their virtual addresses, plus offsets of 0x4, 0x8 and 0xC, respectively. See [Section 12.3 “CLR, SET, and INV Registers”](#) for more information.

TABLE 29-2: CAN2 REGISTER SUMMARY FOR PIC32MZXXXECF AND PIC32MZXXXECH DEVICES (CONTINUED)

| Virtual Address (BF88_#) | Register Name ⁽¹⁾ | Bit Range | Bits | | | | | | | | | | | | | | All Resets | | | | | |
|--------------------------|--|-----------|-----------------|-------------|-------|-------|-------|-------|-----------|-------------|-----------|-----------|-------------|-------|-------|----------------|----------------|----------|------------|------------|------|------|
| | | | 31/15 | 30/14 | 29/13 | 28/12 | 27/11 | 26/10 | 25/9 | 24/8 | 23/7 | 22/6 | 21/5 | 20/4 | 19/3 | 18/2 | | 17/1 | 16/0 | | | |
| 1100 | C2FLTCON4 | 31:16 | FLTEN19 | MSEL19<1:0> | | | | | | FSEL19<4:0> | | FLTEN18 | MSEL18<1:0> | | | FSEL18<4:0> | | 0000 | | | | |
| | | 15:0 | FLTEN17 | MSEL17<1:0> | | | | | | FSEL17<4:0> | | FLTEN16 | MSEL16<1:0> | | | FSEL16<4:0> | | 0000 | | | | |
| 1110 | C2FLTCON5 | 31:16 | FLTEN23 | MSEL23<1:0> | | | | | | FSEL23<4:0> | | FLTEN22 | MSEL22<1:0> | | | FSEL22<4:0> | | 0000 | | | | |
| | | 15:0 | FLTEN21 | MSEL21<1:0> | | | | | | FSEL21<4:0> | | FLTEN20 | MSEL20<1:0> | | | FSEL20<4:0> | | 0000 | | | | |
| 1120 | C2FLTCON6 | 31:16 | FLTEN27 | MSEL27<1:0> | | | | | | FSEL27<4:0> | | FLTEN26 | MSEL26<1:0> | | | FSEL26<4:0> | | 0000 | | | | |
| | | 15:0 | FLTEN25 | MSEL25<1:0> | | | | | | FSEL25<4:0> | | FLTEN24 | MSEL24<1:0> | | | FSEL24<4:0> | | 0000 | | | | |
| 1130 | C2FLTCON7 | 31:16 | FLTEN31 | MSEL31<1:0> | | | | | | FSEL31<4:0> | | FLTEN30 | MSEL30<1:0> | | | FSEL30<4:0> | | 0000 | | | | |
| | | 15:0 | FLTEN29 | MSEL29<1:0> | | | | | | FSEL29<4:0> | | FLTEN28 | MSEL28<1:0> | | | FSEL28<4:0> | | 0000 | | | | |
| 1140-1330 | C2RXFn (n = 0-31) | 31:16 | SID<10:0> | | | | | | | | | | --- | EXID | --- | EID<17:16> | xxxx | | | | | |
| | | 15:0 | EID<15:0> | | | | | | | | | | | | | | xxxx | | | | | |
| 1340 | C2FIFOBA | 31:16 | | | | | | | | | | | | | | | 0000 | | | | | |
| | | 15:0 | C2FIFOBA<31:0> | | | | | | | | | | | | | | 0000 | | | | | |
| 1350 | C2FIFOCONn (n = 0) | 31:16 | --- | --- | --- | --- | --- | --- | --- | --- | --- | --- | --- | --- | --- | --- | --- | --- | FSIZE<4:0> | 0000 | | |
| | | 15:0 | --- | FRESET | UINC | DONLY | --- | --- | --- | --- | TXEN | TXABAT | TXLARB | TXERR | TXREQ | RTREN | TXPRI<1:0> | | | 0000 | | |
| 1360 | C2FIFOINTn (n = 0) | 31:16 | --- | --- | --- | --- | --- | --- | TXNFULLIE | TXHALFIE | TXEMPTYIE | --- | --- | --- | --- | RXOVFLIE | RXFULLIE | RXHALFIE | RXNEMPTYIE | 0000 | | |
| | | 15:0 | --- | --- | --- | --- | --- | --- | TXNFULLIF | TXHALFIF | TXEMPTYIF | --- | --- | --- | --- | RXOVFLIF | RXFULLIF | RXHALFIF | RXNEMPTYIF | 0000 | | |
| 1370 | C2FIFOUAN (n = 0) | 31:16 | | | | | | | | | | | | | | | 0000 | | | | | |
| | | 15:0 | C2FIFOUA<31:0> | | | | | | | | | | | | | | 0000 | | | | | |
| 1380 | C2FIFOCONn (n = 0) | 31:16 | --- | --- | --- | --- | --- | --- | --- | --- | --- | --- | --- | --- | --- | --- | --- | --- | --- | 0000 | | |
| | | 15:0 | --- | --- | --- | --- | --- | --- | --- | --- | --- | --- | --- | --- | --- | C2FIFOCON<4:0> | | | 0000 | | | |
| 1390-1B40 | C2FIFOCONn C2FIFOINTn C2FIFOUAN C2FIFOCONn (n = 1-31) | 31:16 | --- | --- | --- | --- | --- | --- | --- | --- | --- | --- | --- | --- | --- | --- | --- | --- | --- | FSIZE<4:0> | 0000 | |
| | | 15:0 | --- | FRESET | UINC | DONLY | --- | --- | --- | --- | TXEN | TXABAT | TXLARB | TXERR | TXREQ | RTREN | TXPRI<1:0> | | | 0000 | | |
| | | 31:16 | --- | --- | --- | --- | --- | --- | --- | TXNFULLIE | TXHALFIE | TXEMPTYIE | --- | --- | --- | --- | RXOVFLIE | RXFULLIE | RXHALFIE | RXNEMPTYIE | 0000 | |
| | | 15:0 | --- | --- | --- | --- | --- | --- | --- | TXNFULLIF | TXHALFIF | TXEMPTYIF | --- | --- | --- | --- | RXOVFLIF | RXFULLIF | RXHALFIF | RXNEMPTYIF | 0000 | |
| | | 31:16 | | | | | | | | | | | | | | | 0000 | | | | | |
| | | 15:0 | C2FIFOUAN<31:0> | | | | | | | | | | | | | | 0000 | | | | | |
| | | 31:16 | --- | --- | --- | --- | --- | --- | --- | --- | --- | --- | --- | --- | --- | --- | --- | --- | --- | --- | --- | 0000 |
| | | 15:0 | --- | --- | --- | --- | --- | --- | --- | --- | --- | --- | --- | --- | --- | --- | C2FIFOCON<4:0> | | | 0000 | | |

Legend: x = unknown value on Reset; --- = unimplemented, read as '0'. Reset values are shown in hexadecimal.

Note 1: All registers in this table have corresponding CLR, SET and INV registers at their virtual addresses, plus offsets of 0x4, 0x8 and 0xC, respectively. See [Section 12.3 "CLR, SET, and INV Registers"](#) for more information.

PIC32MZ Embedded Connectivity with Floating Point Unit (EF) Family

REGISTER 29-1: CiCON: CAN MODULE CONTROL REGISTER

| Bit Range | Bit 31/23/15/7 | Bit 30/22/14/6 | Bit 29/21/13/5 | Bit 28/20/12/4 | Bit 27/19/11/3 | Bit 26/18/10/2 | Bit 25/17/9/1 | Bit 24/16/8/0 |
|-----------|-------------------|----------------|----------------|----------------|----------------|----------------|---------------|---------------|
| 31:24 | U-0 | U-0 | U-0 | U-0 | S/HC-0 | R/W-1 | R/W-0 | R/W-0 |
| | — | — | — | — | ABAT | REQOP<2:0> | | |
| 23:16 | R-1 | R-0 | R-0 | R/W-0 | U-0 | U-0 | U-0 | U-0 |
| | OPMOD<2:0> | | | CANCAP | — | — | — | — |
| 15:8 | R/W-0 | U-0 | R/W-0 | U-0 | R-0 | U-0 | U-0 | U-0 |
| | ON ⁽¹⁾ | — | SIDLE | — | CANBUSY | — | — | — |
| 7:0 | U-0 | U-0 | U-0 | R/W-0 | R/W-0 | R/W-0 | R/W-0 | R/W-0 |
| | — | — | — | DNCNT<4:0> | | | | |

Legend: HC = Hardware Clear S = Settable bit
R = Readable bit W = Writable bit P = Programmable bit r = Reserved bit
U = Unimplemented bit -n = Bit Value at POR: ('0', '1', x = Unknown)

bit 31-28 **Unimplemented:** Read as '0'

bit 27 **ABAT:** Abort All Pending Transmissions bit
1 = Signal all transmit buffers to abort transmission
0 = Module will clear this bit when all transmissions aborted

bit 26-24 **REQOP<2:0>:** Request Operation Mode bits
111 = Set Listen All Messages mode
110 = Reserved - Do not use
101 = Reserved - Do not use
100 = Set Configuration mode
011 = Set Listen Only mode
010 = Set Loopback mode
001 = Set Disable mode
000 = Set Normal Operation mode

bit 23-21 **OPMOD<2:0>:** Operation Mode Status bits
111 = Module is in Listen All Messages mode
110 = Reserved
101 = Reserved
100 = Module is in Configuration mode
011 = Module is in Listen Only mode
010 = Module is in Loopback mode
001 = Module is in Disable mode
000 = Module is in Normal Operation mode

bit 20 **CANCAP:** CAN Message Receive Time Stamp Timer Capture Enable bit
1 = CANTMR value is stored on valid message reception and is stored with the message
0 = Disable CAN message receive time stamp timer capture and stop CANTMR to conserve power

bit 19-16 **Unimplemented:** Read as '0'

bit 15 **ON:** CAN On bit⁽¹⁾
1 = CAN module is enabled
0 = CAN module is disabled

bit 14 **Unimplemented:** Read as '0'

Note 1: If the user application clears this bit, it may take a number of cycles before the CAN module completes the current transaction and responds to this request. The user application should poll the CANBUSY bit to verify that the request has been honored.

PIC32MZ Embedded Connectivity with Floating Point Unit (EF) Family

REGISTER 29-1: CiCON: CAN MODULE CONTROL REGISTER (CONTINUED)

- bit 13 **SIDLE:** CAN Stop in Idle bit
 1 = CAN Stops operation when system enters Idle mode
 0 = CAN continues operation when system enters Idle mode
- bit 12 **Unimplemented:** Read as '0'
- bit 11 **CANBUSY:** CAN Module is Busy bit
 1 = The CAN module is active
 0 = The CAN module is completely disabled
- bit 10-5 **Unimplemented:** Read as '0'
- bit 4-0 **DNCNT<4:0>:** Device Net Filter Bit Number bits
 10011-11111 = Invalid Selection (compare up to 18-bits of data with EID)
 10010 = Compare up to data byte 2 bit 6 with EID17 (CiRXFn<17>)
 •
 •
 •
 00001 = Compare up to data byte 0 bit 7 with EID0 (CiRXFn<0>)
 00000 = Do not compare data bytes

Note 1: If the user application clears this bit, it may take a number of cycles before the CAN module completes the current transaction and responds to this request. The user application should poll the CANBUSY bit to verify that the request has been honored.

PIC32MZ Embedded Connectivity with Floating Point Unit (EF) Family

REGISTER 29-2: CiCFG: CAN BAUD RATE CONFIGURATION REGISTER

| Bit Range | Bit 31/23/15/7 | Bit 30/22/14/6 | Bit 29/21/13/5 | Bit 28/20/12/4 | Bit 27/19/11/3 | Bit 26/18/10/2 | Bit 25/17/9/1 | Bit 24/16/8/0 |
|-----------|-------------------------|--------------------|----------------|----------------|----------------|------------------------------|---------------|---------------|
| 31:24 | U-0 | U-0 | U-0 | U-0 | U-0 | U-0 | U-0 | U-0 |
| | — | — | — | — | — | — | — | — |
| 23:16 | U-0 | R/W-0 | U-0 | U-0 | U-0 | R/W-0 | R/W-0 | R/W-0 |
| | — | WAKFIL | — | — | — | SEG2PH<2:0> ^(1,4) | | |
| 15:8 | R/W-0 | R/W-0 | R/W-0 | R/W-0 | R/W-0 | R/W-0 | R/W-0 | R/W-0 |
| | SEG2PHTS ⁽¹⁾ | SAM ⁽²⁾ | SEG1PH<2:0> | | | PRSEG<2:0> | | |
| 7:0 | R/W-0 | R/W-0 | R/W-0 | R/W-0 | R/W-0 | R/W-0 | R/W-0 | R/W-0 |
| | SJW<1:0> ⁽³⁾ | | BRP<5:0> | | | | | |

Legend: HC = Hardware Clear S = Settable bit
R = Readable bit W = Writable bit P = Programmable bit r = Reserved bit
U = Unimplemented bit -n = Bit Value at POR: ('0', '1', x = Unknown)

bit 31-23 **Unimplemented:** Read as '0'

bit 22 **WAKFIL:** CAN Bus Line Filter Enable bit
1 = Use CAN bus line filter for wake-up
0 = CAN bus line filter is not used for wake-up

bit 21-19 **Unimplemented:** Read as '0'

bit 18-16 **SEG2PH<2:0>:** Phase Buffer Segment 2 bits^(1,4)
111 = Length is 8 x Tq
•
•
•
000 = Length is 1 x Tq

bit 15 **SEG2PHTS:** Phase Segment 2 Time Select bit⁽¹⁾
1 = Freely programmable
0 = Maximum of SEG1PH or Information Processing Time, whichever is greater

bit 14 **SAM:** Sample of the CAN Bus Line bit⁽²⁾
1 = Bus line is sampled three times at the sample point
0 = Bus line is sampled once at the sample point

bit 13-11 **SEG1PH<2:0>:** Phase Buffer Segment 1 bits⁽⁴⁾
111 = Length is 8 x Tq
•
•
•
000 = Length is 1 x Tq

- Note 1:** $SEG2PH \leq SEG1PH$. If SEG2PHTS is clear, SEG2PH will be set automatically.
Note 2: 3 Time bit sampling is not allowed for $BRP < 2$.
Note 3: $SJW \leq SEG2PH$.
Note 4: The Time Quanta per bit must be greater than 7 (that is, $TQBIT > 7$).

Note: This register can only be modified when the CAN module is in Configuration mode ($OPMOD<2:0> (CiCON<23:21>) = 100$).

PIC32MZ Embedded Connectivity with Floating Point Unit (EF) Family

REGISTER 29-2: CiCFG: CAN BAUD RATE CONFIGURATION REGISTER (CONTINUED)

bit 10-8 **PRSEG<2:0>**: Propagation Time Segment bits⁽⁴⁾

111 = Length is 8 x T_Q

-
-
-

000 = Length is 1 x T_Q

bit 7-6 **SJW<1:0>**: Synchronization Jump Width bits⁽³⁾

11 = Length is 4 x T_Q

10 = Length is 3 x T_Q

01 = Length is 2 x T_Q

00 = Length is 1 x T_Q

bit 5-0 **BRP<5:0>**: Baud Rate Prescaler bits

111111 = T_Q = (2 x 64)/TPBCLK5

111110 = T_Q = (2 x 63)/TPBCLK5

-
-
-

000001 = T_Q = (2 x 2)/TPBCLK5

000000 = T_Q = (2 x 1)/TPBCLK5

Note 1: SEG2PH ≤ SEG1PH. If SEG2PHTS is clear, SEG2PH will be set automatically.

2: 3 Time bit sampling is not allowed for BRP < 2.

3: SJW ≤ SEG2PH.

4: The Time Quanta per bit must be greater than 7 (that is, T_{QBIT} > 7).

Note: This register can only be modified when the CAN module is in Configuration mode (OPMOD<2:0> (CiCON<23:21>) = 100).

PIC32MZ Embedded Connectivity with Floating Point Unit (EF) Family

REGISTER 29-3: CiINT: CAN INTERRUPT REGISTER

| Bit Range | Bit 31/23/15/7 | Bit 30/22/14/6 | Bit 29/21/13/5 | Bit 28/20/12/4 | Bit 27/19/11/3 | Bit 26/18/10/2 | Bit 25/17/9/1 | Bit 24/16/8/0 |
|-----------|----------------|----------------|----------------|-----------------------|----------------|----------------|---------------|---------------|
| 31:24 | R/W-0 | R/W-0 | R/W-0 | R/W-0 | R/W-0 | U-0 | U-0 | U-0 |
| | IVRIE | WAKIE | CERRIE | SERRIE | RBOVIE | — | — | — |
| 23:16 | U-0 | U-0 | U-0 | U-0 | R/W-0 | R/W-0 | R/W-0 | R/W-0 |
| | — | — | — | — | MODIE | CTMRIE | RBIE | TBIE |
| 15:8 | R/W-0 | R/W-0 | R/W-0 | R/W-0 | R/W-0 | U-0 | U-0 | U-0 |
| | IVRIF | WAKIF | CERRIF | SERRIF ⁽¹⁾ | RBOVIF | — | — | — |
| 7:0 | U-0 | U-0 | U-0 | U-0 | R/W-0 | R/W-0 | R/W-0 | R/W-0 |
| | — | — | — | — | MODIF | CTMRIF | RBIF | TBIF |

Legend:

R = Readable bit W = Writable bit U = Unimplemented bit, read as '0'
 -n = Value at POR '1' = Bit is set '0' = Bit is cleared x = Bit is unknown

- bit 31 **IVRIE:** Invalid Message Received Interrupt Enable bit
 1 = Interrupt request enabled
 0 = Interrupt request not enabled
- bit 30 **WAKIE:** CAN Bus Activity Wake-up Interrupt Enable bit
 1 = Interrupt request enabled
 0 = Interrupt request not enabled
- bit 29 **CERRIE:** CAN Bus Error Interrupt Enable bit
 1 = Interrupt request enabled
 0 = Interrupt request not enabled
- bit 28 **SERRIE:** System Error Interrupt Enable bit
 1 = Interrupt request enabled
 0 = Interrupt request not enabled
- bit 27 **RBOVIE:** Receive Buffer Overflow Interrupt Enable bit
 1 = Interrupt request enabled
 0 = Interrupt request not enabled
- bit 26-20 **Unimplemented:** Read as '0'
- bit 19 **MODIE:** Mode Change Interrupt Enable bit
 1 = Interrupt request enabled
 0 = Interrupt request not enabled
- bit 18 **CTMRIE:** CAN Timestamp Timer Interrupt Enable bit
 1 = Interrupt request enabled
 0 = Interrupt request not enabled
- bit 17 **RBIE:** Receive Buffer Interrupt Enable bit
 1 = Interrupt request enabled
 0 = Interrupt request not enabled
- bit 16 **TBIE:** Transmit Buffer Interrupt Enable bit
 1 = Interrupt request enabled
 0 = Interrupt request not enabled
- bit 15 **IVRIF:** Invalid Message Received Interrupt Flag bit
 1 = An invalid messages interrupt has occurred
 0 = An invalid message interrupt has not occurred

Note 1: This bit can only be cleared by turning the CAN module Off and On by clearing or setting the ON bit (CiCON<15>).

REGISTER 29-3: CiINT: CAN INTERRUPT REGISTER (CONTINUED)

- bit 14 **WAKIF:** CAN Bus Activity Wake-up Interrupt Flag bit
1 = A bus wake-up activity interrupt has occurred
0 = A bus wake-up activity interrupt has not occurred
- bit 13 **CERRIF:** CAN Bus Error Interrupt Flag bit
1 = A CAN bus error has occurred
0 = A CAN bus error has not occurred
- bit 12 **SERRIF:** System Error Interrupt Flag bit
1 = A system error occurred (typically an illegal address was presented to the System Bus)
0 = A system error has not occurred
- bit 11 **RBOVIF:** Receive Buffer Overflow Interrupt Flag bit
1 = A receive buffer overflow has occurred
0 = A receive buffer overflow has not occurred
- bit 10-4 **Unimplemented:** Read as '0'
- bit 3 **MODIF:** CAN Mode Change Interrupt Flag bit
1 = A CAN module mode change has occurred (OPMOD<2:0> has changed to reflect REQOP)
0 = A CAN module mode change has not occurred
- bit 2 **CTMRIF:** CAN Timer Overflow Interrupt Flag bit
1 = A CAN timer (CANTMR) overflow has occurred
0 = A CAN timer (CANTMR) overflow has not occurred
- bit 1 **RBIF:** Receive Buffer Interrupt Flag bit
1 = A receive buffer interrupt is pending
0 = A receive buffer interrupt is not pending
- bit 0 **TBIF:** Transmit Buffer Interrupt Flag bit
1 = A transmit buffer interrupt is pending
0 = A transmit buffer interrupt is not pending

Note 1: This bit can only be cleared by turning the CAN module Off and On by clearing or setting the ON bit (CiCON<15>).

PIC32MZ Embedded Connectivity with Floating Point Unit (EF) Family

REGISTER 29-4: CIVEC: CAN INTERRUPT CODE REGISTER

| Bit Range | Bit 31/23/15/7 | Bit 30/22/14/6 | Bit 29/21/13/5 | Bit 28/20/12/4 | Bit 27/19/11/3 | Bit 26/18/10/2 | Bit 25/17/9/1 | Bit 24/16/8/0 |
|-----------|----------------|---------------------------|----------------|----------------|----------------|----------------|---------------|---------------|
| 31:24 | U-0 | U-0 | U-0 | U-0 | U-0 | U-0 | U-0 | U-0 |
| | — | — | — | — | — | — | — | — |
| 23:16 | U-0 | U-0 | U-0 | U-0 | U-0 | U-0 | U-0 | U-0 |
| | — | — | — | — | — | — | — | — |
| 15:8 | U-0 | U-0 | U-0 | R-0 | R-0 | R-0 | R-0 | R-0 |
| | — | — | — | FILHIT<4:0> | | | | |
| 7:0 | U-0 | R-1 | R-0 | R-0 | R-0 | R-0 | R-0 | R-0 |
| | — | ICODE<6:0> ⁽¹⁾ | | | | | | |

Legend:

R = Readable bit W = Writable bit U = Unimplemented bit, read as '0'
 -n = Value at POR '1' = Bit is set '0' = Bit is cleared x = Bit is unknown

bit 31-13 **Unimplemented:** Read as '0'

bit 12-8 **FILHIT<4:0>:** Filter Hit Number bit

11111 = Filter 31
 11110 = Filter 30

•
•
•

00001 = Filter 1
 00000 = Filter 0

bit 7 **Unimplemented:** Read as '0'

bit 6-0 **ICODE<6:0>:** Interrupt Flag Code bits⁽¹⁾

1001000-1111111 = Reserved
 1001000 = Invalid message received (IVRIF)
 1000111 = CAN module mode change (MODIF)
 1000110 = CAN timestamp timer (CTMRIF)
 1000101 = Bus bandwidth error (SERRIF)
 1000100 = Address error interrupt (SERRIF)
 1000011 = Receive FIFO overflow interrupt (RBOVIF)
 1000010 = Wake-up interrupt (WAKIF)
 1000001 = Error Interrupt (CERRIF)
 1000000 = No interrupt
 0100000-0111111 = Reserved
 0011111 = FIFO31 Interrupt (CiFSTAT<31> set)
 0011110 = FIFO30 Interrupt (CiFSTAT<30> set)
 •
•
•
 0000001 = FIFO01 Interrupt (CiFSTAT<1> set)
 0000000 = FIFO00 Interrupt (CiFSTAT<0> set)

Note 1: These bits are only updated for enabled interrupts.

PIC32MZ Embedded Connectivity with Floating Point Unit (EF) Family

REGISTER 29-5: CITREC: CAN TRANSMIT/RECEIVE ERROR COUNT REGISTER

| Bit Range | Bit 31/23/15/7 | Bit 30/22/14/6 | Bit 29/21/13/5 | Bit 28/20/12/4 | Bit 27/19/11/3 | Bit 26/18/10/2 | Bit 25/17/9/1 | Bit 24/16/8/0 |
|-----------|----------------|----------------|----------------|----------------|----------------|----------------|---------------|---------------|
| 31:24 | U-0 | U-0 | U-0 | U-0 | U-0 | U-0 | U-0 | U-0 |
| | — | — | — | — | — | — | — | — |
| 23:16 | U-0 | U-0 | R-0 | R-0 | R-0 | R-0 | R-0 | R-0 |
| | — | — | TXBO | TXBP | RXBP | TXWARN | RXWARN | EWARN |
| 15:8 | R-0 | R-0 | R-0 | R-0 | R-0 | R-0 | R-0 | R-0 |
| | TERRCNT<7:0> | | | | | | | |
| 7:0 | R-0 | R-0 | R-0 | R-0 | R-0 | R-0 | R-0 | R-0 |
| | RERRCNT<7:0> | | | | | | | |

Legend:

R = Readable bit W = Writable bit U = Unimplemented bit, read as '0'
 -n = Value at POR '1' = Bit is set '0' = Bit is cleared x = Bit is unknown

- bit 31-22 **Unimplemented:** Read as '0'
- bit 21 **TXBO:** Transmitter in Error State Bus OFF (TERRCNT ≥ 256)
- bit 20 **TXBP:** Transmitter in Error State Bus Passive (TERRCNT ≥ 128)
- bit 19 **RXBP:** Receiver in Error State Bus Passive (RERRCNT ≥ 128)
- bit 18 **TXWARN:** Transmitter in Error State Warning (128 > TERRCNT ≥ 96)
- bit 17 **RXWARN:** Receiver in Error State Warning (128 > RERRCNT ≥ 96)
- bit 16 **EWARN:** Transmitter or Receiver is in Error State Warning
- bit 15-8 **TERRCNT<7:0>:** Transmit Error Counter
- bit 7-0 **RERRCNT<7:0>:** Receive Error Counter

REGISTER 29-6: CIFSTAT: CAN FIFO STATUS REGISTER

| Bit Range | Bit 31/23/15/7 | Bit 30/22/14/6 | Bit 29/21/13/5 | Bit 28/20/12/4 | Bit 27/19/11/3 | Bit 26/18/10/2 | Bit 25/17/9/1 | Bit 24/16/8/0 |
|-----------|----------------|----------------|----------------|----------------|----------------|----------------|---------------|---------------|
| 31:24 | R-0 | R-0 | R-0 | R-0 | R-0 | R-0 | R-0 | R-0 |
| | FIFOIP31 | FIFOIP30 | FIFOIP29 | FIFOIP28 | FIFOIP27 | FIFOIP26 | FIFOIP25 | FIFOIP24 |
| 23:16 | R-0 | R-0 | R-0 | R-0 | R-0 | R-0 | R-0 | R-0 |
| | FIFOIP23 | FIFOIP22 | FIFOIP21 | FIFOIP20 | FIFOIP19 | FIFOIP18 | FIFOIP17 | FIFOIP16 |
| 15:8 | R-0 | R-0 | R-0 | R-0 | R-0 | R-0 | R-0 | R-0 |
| | FIFOIP15 | FIFOIP14 | FIFOIP13 | FIFOIP12 | FIFOIP11 | FIFOIP10 | FIFOIP9 | FIFOIP8 |
| 7:0 | R-0 | R-0 | R-0 | R-0 | R-0 | R-0 | R-0 | R-0 |
| | FIFOIP7 | FIFOIP6 | FIFOIP5 | FIFOIP4 | FIFOIP3 | FIFOIP2 | FIFOIP1 | FIFOIP0 |

Legend:

R = Readable bit W = Writable bit U = Unimplemented bit, read as '0'
 -n = Value at POR '1' = Bit is set '0' = Bit is cleared x = Bit is unknown

- bit 31-0 **FIFOIP<31:0>:** FIFOx Interrupt Pending bits
 - 1 = One or more enabled FIFO interrupts are pending
 - 0 = No FIFO interrupts are pending

PIC32MZ Embedded Connectivity with Floating Point Unit (EF) Family

REGISTER 29-7: C_iRXOVF: CAN RECEIVE FIFO OVERFLOW STATUS REGISTER

| Bit Range | Bit 31/23/15/7 | Bit 30/22/14/6 | Bit 29/21/13/5 | Bit 28/20/12/4 | Bit 27/19/11/3 | Bit 26/18/10/2 | Bit 25/17/9/1 | Bit 24/16/8/0 |
|-----------|----------------|----------------|----------------|----------------|----------------|----------------|---------------|---------------|
| 31:24 | R-0 | R-0 | R-0 | R-0 | R-0 | R-0 | R-0 | R-0 |
| | RXOVF31 | RXOVF30 | RXOVF29 | RXOVF28 | RXOVF27 | RXOVF26 | RXOVF25 | RXOVF24 |
| 23:16 | R-0 | R-0 | R-0 | R-0 | R-0 | R-0 | R-0 | R-0 |
| | RXOVF23 | RXOVF22 | RXOVF21 | RXOVF20 | RXOVF19 | RXOVF18 | RXOVF17 | RXOVF16 |
| 15:8 | R-0 | R-0 | R-0 | R-0 | R-0 | R-0 | R-0 | R-0 |
| | RXOVF15 | RXOVF14 | RXOVF13 | RXOVF12 | RXOVF11 | RXOVF10 | RXOVF9 | RXOVF8 |
| 7:0 | R-0 | R-0 | R-0 | R-0 | R-0 | R-0 | R-0 | R-0 |
| | RXOVF7 | RXOVF6 | RXOVF5 | RXOVF4 | RXOVF3 | RXOVF2 | RXOVF1 | RXOVF0 |

Legend:

R = Readable bit W = Writable bit U = Unimplemented bit, read as '0'
 -n = Value at POR '1' = Bit is set '0' = Bit is cleared x = Bit is unknown

bit 31-0 **RXOVF<31:0>**: FIFOx Receive Overflow Interrupt Pending bit

- 1 = FIFO has overflowed
- 0 = FIFO has not overflowed

REGISTER 29-8: C_iTMR: CAN TIMER REGISTER

| Bit Range | Bit 31/23/15/7 | Bit 30/22/14/6 | Bit 29/21/13/5 | Bit 28/20/12/4 | Bit 27/19/11/3 | Bit 26/18/10/2 | Bit 25/17/9/1 | Bit 24/16/8/0 |
|-----------|----------------|----------------|----------------|----------------|----------------|----------------|---------------|---------------|
| 31:24 | R/W-0 | R/W-0 | R/W-0 | R/W-0 | R/W-0 | R/W-0 | R/W-0 | R/W-0 |
| | CANTS<15:8> | | | | | | | |
| 23:16 | R/W-0 | R/W-0 | R/W-0 | R/W-0 | R/W-0 | R/W-0 | R/W-0 | R/W-0 |
| | CANTS<7:0> | | | | | | | |
| 15:8 | R/W-0 | R/W-0 | R/W-0 | R/W-0 | R/W-0 | R/W-0 | R/W-0 | R/W-0 |
| | CANTSPRE<15:8> | | | | | | | |
| 7:0 | R/W-0 | R/W-0 | R/W-0 | R/W-0 | R/W-0 | R/W-0 | R/W-0 | R/W-0 |
| | CANTSPRE<7:0> | | | | | | | |

Legend:

R = Readable bit W = Writable bit U = Unimplemented bit, read as '0'
 -n = Value at POR '1' = Bit is set '0' = Bit is cleared x = Bit is unknown

bit 31-0 **CANTS<15:0>**: CAN Time Stamp Timer bits

This is a free-running timer that increments every CANTSPRE system clocks when the CANCAP bit (C_iCON<20>) is set.

bit 15-0 **CANTSPRE<15:0>**: CAN Time Stamp Timer Prescaler bits

1111 1111 1111 1111 = CAN time stamp timer (CANTS) increments every 65,535 system clocks

-
-
-

0000 0000 0000 0000 = CAN time stamp timer (CANTS) increments every system clock

Note 1: C_iTMR will be frozen when CANCAP = 0.

Note 2: The C_iTMR prescaler count will be reset on any write to C_iTMR (CANTSPRE will be unaffected).

PIC32MZ Embedded Connectivity with Floating Point Unit (EF) Family

REGISTER 29-9: CiRXMN: CAN ACCEPTANCE FILTER MASK 'n' REGISTER ('n' = 0-3)

| Bit Range | Bit 31/23/15/7 | Bit 30/22/14/6 | Bit 29/21/13/5 | Bit 28/20/12/4 | Bit 27/19/11/3 | Bit 26/18/10/2 | Bit 25/17/9/1 | Bit 24/16/8/0 |
|-----------|----------------|----------------|----------------|----------------|----------------|----------------|---------------|---------------|
| 31:24 | R/W-0 | R/W-0 | R/W-0 | R/W-0 | R/W-0 | R/W-0 | R/W-0 | R/W-0 |
| SID<10:3> | | | | | | | | |
| 23:16 | R/W-0 | R/W-0 | R/W-0 | U-0 | R/W-0 | U-0 | R/W-0 | R/W-0 |
| SID<2:0> | | | — | MIDE | — | EID<17:16> | | |
| 15:8 | R/W-0 | R/W-0 | R/W-0 | R/W-0 | R/W-0 | R/W-0 | R/W-0 | R/W-0 |
| EID<15:8> | | | | | | | | |
| 7:0 | R/W-0 | R/W-0 | R/W-0 | R/W-0 | R/W-0 | R/W-0 | R/W-0 | R/W-0 |
| EID<7:0> | | | | | | | | |

Legend:

R = Readable bit W = Writable bit U = Unimplemented bit, read as '0'
 -n = Value at POR '1' = Bit is set '0' = Bit is cleared x = Bit is unknown

bit 31-21 **SID<10:0>**: Standard Identifier bits

- 1 = Include bit, SIDx, in filter comparison
- 0 = Bit SIDx is 'don't care' in filter operation

bit 20 **Unimplemented**: Read as '0'

bit 19 **MIDE**: Identifier Receive Mode bit

- 1 = Match only message types (standard/extended address) that correspond to the EXID bit in filter
- 0 = Match either standard or extended address message if filters match (that is, if (Filter SID) = (Message SID) or if (FILTER SID/EID) = (Message SID/EID))

bit 18 **Unimplemented**: Read as '0'

bit 17-0 **EID<17:0>**: Extended Identifier bits

- 1 = Include bit, EIDx, in filter comparison
- 0 = Bit EIDx is 'don't care' in filter operation

Note: This register can only be modified when the CAN module is in Configuration mode (OPMOD<2:0> (CiCON<23:21>) = 100).

PIC32MZ Embedded Connectivity with Floating Point Unit (EF) Family

REGISTER 29-10: CiFLTCON0: CAN FILTER CONTROL REGISTER 0

| Bit Range | Bit 31/23/15/7 | Bit 30/22/14/6 | Bit 29/21/13/5 | Bit 28/20/12/4 | Bit 27/19/11/3 | Bit 26/18/10/2 | Bit 25/17/9/1 | Bit 24/16/8/0 |
|-----------|-------------------|-------------------|-------------------|-------------------|-------------------|-------------------|------------------|------------------|
| 31:24 | R/W-0 | R/W-0 | R/W-0 | R/W-0 | R/W-0 | R/W-0 | R/W-0 | R/W-0 |
| | FLTEN3 | MSEL3<1:0> | | FSEL3<4:0> | | | | |
| 23:16 | R/W-0 | R/W-0 | R/W-0 | R/W-0 | R/W-0 | R/W-0 | R/W-0 | R/W-0 |
| | FLTEN2 | MSEL2<1:0> | | FSEL2<4:0> | | | | |
| 15:8 | R/W-0 | R/W-0 | R/W-0 | R/W-0 | R/W-0 | R/W-0 | R/W-0 | R/W-0 |
| | FLTEN1 | MSEL1<1:0> | | FSEL1<4:0> | | | | |
| 7:0 | R/W-0 | R/W-0 | R/W-0 | R/W-0 | R/W-0 | R/W-0 | R/W-0 | R/W-0 |
| | FLTEN0 | MSEL0<1:0> | | FSEL0<4:0> | | | | |

Legend:

R = Readable bit W = Writable bit U = Unimplemented bit, read as '0'
-n = Value at POR '1' = Bit is set '0' = Bit is cleared x = Bit is unknown

bit 31 **FLTEN3:** Filter 3 Enable bit

1 = Filter is enabled
0 = Filter is disabled

bit 30-29 **MSEL3<1:0>:** Filter 3 Mask Select bits

11 = Acceptance Mask 3 selected
10 = Acceptance Mask 2 selected
01 = Acceptance Mask 1 selected
00 = Acceptance Mask 0 selected

bit 28-24 **FSEL3<4:0>:** FIFO Selection bits

11111 = Message matching filter is stored in FIFO buffer 31
11110 = Message matching filter is stored in FIFO buffer 30

•
•
•

00001 = Message matching filter is stored in FIFO buffer 1
00000 = Message matching filter is stored in FIFO buffer 0

bit 23 **FLTEN2:** Filter 2 Enable bit

1 = Filter is enabled
0 = Filter is disabled

bit 22-21 **MSEL2<1:0>:** Filter 2 Mask Select bits

11 = Acceptance Mask 3 selected
10 = Acceptance Mask 2 selected
01 = Acceptance Mask 1 selected
00 = Acceptance Mask 0 selected

bit 20-16 **FSEL2<4:0>:** FIFO Selection bits

11111 = Message matching filter is stored in FIFO buffer 31
11110 = Message matching filter is stored in FIFO buffer 30

•
•
•

00001 = Message matching filter is stored in FIFO buffer 1
00000 = Message matching filter is stored in FIFO buffer 0

Note: The bits in this register can only be modified if the corresponding filter enable (FLTENn) bit is '0'.

PIC32MZ Embedded Connectivity with Floating Point Unit (EF) Family

REGISTER 29-10: CiFLTCON0: CAN FILTER CONTROL REGISTER 0 (CONTINUED)

| | |
|-----------|---|
| bit 15 | FLTEN1: Filter 1 Enable bit 1 = Filter is enabled 0 = Filter is disabled |
| bit 14-13 | MSEL1<1:0>: Filter 1 Mask Select bits 11 = Acceptance Mask 3 selected 10 = Acceptance Mask 2 selected 01 = Acceptance Mask 1 selected 00 = Acceptance Mask 0 selected |
| bit 12-8 | FSEL1<4:0>: FIFO Selection bits 11111 = Message matching filter is stored in FIFO buffer 31 11110 = Message matching filter is stored in FIFO buffer 30 • • • 00001 = Message matching filter is stored in FIFO buffer 1 00000 = Message matching filter is stored in FIFO buffer 0 |
| bit 7 | FLTEN0: Filter 0 Enable bit 1 = Filter is enabled 0 = Filter is disabled |
| bit 6-5 | MSEL0<1:0>: Filter 0 Mask Select bits 11 = Acceptance Mask 3 selected 10 = Acceptance Mask 2 selected 01 = Acceptance Mask 1 selected 00 = Acceptance Mask 0 selected |
| bit 4-0 | FSEL0<4:0>: FIFO Selection bits 11111 = Message matching filter is stored in FIFO buffer 31 11110 = Message matching filter is stored in FIFO buffer 30 • • • 00001 = Message matching filter is stored in FIFO buffer 1 00000 = Message matching filter is stored in FIFO buffer 0 |

Note: The bits in this register can only be modified if the corresponding filter enable (FLTENn) bit is '0'.

PIC32MZ Embedded Connectivity with Floating Point Unit (EF) Family

REGISTER 29-11: CifLTCON1: CAN FILTER CONTROL REGISTER 1

| Bit Range | Bit 31/23/15/7 | Bit 30/22/14/6 | Bit 29/21/13/5 | Bit 28/20/12/4 | Bit 27/19/11/3 | Bit 26/18/10/2 | Bit 25/17/9/1 | Bit 24/16/8/0 |
|-----------|----------------|----------------|----------------|----------------|----------------|----------------|---------------|---------------|
| 31:24 | R/W-0 | R/W-0 | R/W-0 | R/W-0 | R/W-0 | R/W-0 | R/W-0 | R/W-0 |
| | FLTEN7 | MSEL7<1:0> | FSEL7<4:0> | | | | | |
| 23:16 | R/W-0 | R/W-0 | R/W-0 | R/W-0 | R/W-0 | R/W-0 | R/W-0 | R/W-0 |
| | FLTEN6 | MSEL6<1:0> | FSEL6<4:0> | | | | | |
| 15:8 | R/W-0 | R/W-0 | R/W-0 | R/W-0 | R/W-0 | R/W-0 | R/W-0 | R/W-0 |
| | FLTEN5 | MSEL5<1:0> | FSEL5<4:0> | | | | | |
| 7:0 | R/W-0 | R/W-0 | R/W-0 | R/W-0 | R/W-0 | R/W-0 | R/W-0 | R/W-0 |
| | FLTEN4 | MSEL4<1:0> | FSEL4<4:0> | | | | | |

Legend:

R = Readable bit W = Writable bit U = Unimplemented bit, read as '0'
 -n = Value at POR '1' = Bit is set '0' = Bit is cleared x = Bit is unknown

bit 31 **FLTEN7**: Filter 7 Enable bit

1 = Filter is enabled
 0 = Filter is disabled

bit 30-29 **MSEL7<1:0>**: Filter 7 Mask Select bits

11 = Acceptance Mask 3 selected
 10 = Acceptance Mask 2 selected
 01 = Acceptance Mask 1 selected
 00 = Acceptance Mask 0 selected

bit 28-24 **FSEL7<4:0>**: FIFO Selection bits

11111 = Message matching filter is stored in FIFO buffer 31
 11110 = Message matching filter is stored in FIFO buffer 30
 •
 •
 •
 00001 = Message matching filter is stored in FIFO buffer 1
 00000 = Message matching filter is stored in FIFO buffer 0

bit 23 **FLTEN6**: Filter 6 Enable bit

1 = Filter is enabled
 0 = Filter is disabled

bit 22-21 **MSEL6<1:0>**: Filter 6 Mask Select bits

11 = Acceptance Mask 3 selected
 10 = Acceptance Mask 2 selected
 01 = Acceptance Mask 1 selected
 00 = Acceptance Mask 0 selected

bit 20-16 **FSEL6<4:0>**: FIFO Selection bits

11111 = Message matching filter is stored in FIFO buffer 31
 11110 = Message matching filter is stored in FIFO buffer 30
 •
 •
 •
 00001 = Message matching filter is stored in FIFO buffer 1
 00000 = Message matching filter is stored in FIFO buffer 0

Note: The bits in this register can only be modified if the corresponding filter enable (FLTENn) bit is '0'.

PIC32MZ Embedded Connectivity with Floating Point Unit (EF) Family

REGISTER 29-11: CIFLTCON1: CAN FILTER CONTROL REGISTER 1 (CONTINUED)

- bit 15 **FLTEN5**: Filter 17 Enable bit
1 = Filter is enabled
0 = Filter is disabled
- bit 14-13 **MSEL5<1:0>**: Filter 5 Mask Select bits
11 = Acceptance Mask 3 selected
10 = Acceptance Mask 2 selected
01 = Acceptance Mask 1 selected
00 = Acceptance Mask 0 selected
- bit 12-8 **FSEL5<4:0>**: FIFO Selection bits
11111 = Message matching filter is stored in FIFO buffer 31
11110 = Message matching filter is stored in FIFO buffer 30
•
•
•
00001 = Message matching filter is stored in FIFO buffer 1
00000 = Message matching filter is stored in FIFO buffer 0
- bit 7 **FLTEN4**: Filter 4 Enable bit
1 = Filter is enabled
0 = Filter is disabled
- bit 6-5 **MSEL4<1:0>**: Filter 4 Mask Select bits
11 = Acceptance Mask 3 selected
10 = Acceptance Mask 2 selected
01 = Acceptance Mask 1 selected
00 = Acceptance Mask 0 selected
- bit 4-0 **FSEL4<4:0>**: FIFO Selection bits
11111 = Message matching filter is stored in FIFO buffer 31
11110 = Message matching filter is stored in FIFO buffer 30
•
•
•
00001 = Message matching filter is stored in FIFO buffer 1
00000 = Message matching filter is stored in FIFO buffer 0

Note: The bits in this register can only be modified if the corresponding filter enable (FLTENn) bit is '0'.

PIC32MZ Embedded Connectivity with Floating Point Unit (EF) Family

REGISTER 29-12: CiFLTCON2: CAN FILTER CONTROL REGISTER 2

| Bit Range | Bit 31/23/15/7 | Bit 30/22/14/6 | Bit 29/21/13/5 | Bit 28/20/12/4 | Bit 27/19/11/3 | Bit 26/18/10/2 | Bit 25/17/9/1 | Bit 24/16/8/0 |
|-----------|----------------|----------------|----------------|----------------|----------------|----------------|---------------|---------------|
| 31:24 | R/W-0 | R/W-0 | R/W-0 | R/W-0 | R/W-0 | R/W-0 | R/W-0 | R/W-0 |
| | FLTEN11 | MSEL11<1:0> | | FSEL11<4:0> | | | | |
| 23:16 | R/W-0 | R/W-0 | R/W-0 | R/W-0 | R/W-0 | R/W-0 | R/W-0 | R/W-0 |
| | FLTEN10 | MSEL10<1:0> | | FSEL10<4:0> | | | | |
| 15:8 | R/W-0 | R/W-0 | R/W-0 | R/W-0 | R/W-0 | R/W-0 | R/W-0 | R/W-0 |
| | FLTEN9 | MSEL9<1:0> | | FSEL9<4:0> | | | | |
| 7:0 | R/W-0 | R/W-0 | R/W-0 | R/W-0 | R/W-0 | R/W-0 | R/W-0 | R/W-0 |
| | FLTEN8 | MSEL8<1:0> | | FSEL8<4:0> | | | | |

Legend:

R = Readable bit W = Writable bit U = Unimplemented bit, read as '0'
 -n = Value at POR '1' = Bit is set '0' = Bit is cleared x = Bit is unknown

bit 31 **FLTEN11**: Filter 11 Enable bit

1 = Filter is enabled
 0 = Filter is disabled

bit 30-29 **MSEL11<1:0>**: Filter 11 Mask Select bits

11 = Acceptance Mask 3 selected
 10 = Acceptance Mask 2 selected
 01 = Acceptance Mask 1 selected
 00 = Acceptance Mask 0 selected

bit 28-24 **FSEL11<4:0>**: FIFO Selection bits

11111 = Message matching filter is stored in FIFO buffer 31
 11110 = Message matching filter is stored in FIFO buffer 30

•
 •
 •

00001 = Message matching filter is stored in FIFO buffer 1
 00000 = Message matching filter is stored in FIFO buffer 0

bit 23 **FLTEN10**: Filter 10 Enable bit

1 = Filter is enabled
 0 = Filter is disabled

bit 22-21 **MSEL10<1:0>**: Filter 10 Mask Select bits

11 = Acceptance Mask 3 selected
 10 = Acceptance Mask 2 selected
 01 = Acceptance Mask 1 selected
 00 = Acceptance Mask 0 selected

bit 20-16 **FSEL10<4:0>**: FIFO Selection bits

11111 = Message matching filter is stored in FIFO buffer 31
 11110 = Message matching filter is stored in FIFO buffer 30

•
 •
 •

00001 = Message matching filter is stored in FIFO buffer 1
 00000 = Message matching filter is stored in FIFO buffer 0

Note: The bits in this register can only be modified if the corresponding filter enable (FLTENn) bit is '0'.

PIC32MZ Embedded Connectivity with Floating Point Unit (EF) Family

REGISTER 29-12: CifLTCON2: CAN FILTER CONTROL REGISTER 2 (CONTINUED)

- bit 15 **FLTEN9**: Filter 9 Enable bit
 1 = Filter is enabled
 0 = Filter is disabled
- bit 14-13 **MSEL9<1:0>**: Filter 9 Mask Select bits
 11 = Acceptance Mask 3 selected
 10 = Acceptance Mask 2 selected
 01 = Acceptance Mask 1 selected
 00 = Acceptance Mask 0 selected
- bit 12-8 **FSEL9<4:0>**: FIFO Selection bits
 11111 = Message matching filter is stored in FIFO buffer 31
 11110 = Message matching filter is stored in FIFO buffer 30
 •
 •
 •
 00001 = Message matching filter is stored in FIFO buffer 1
 00000 = Message matching filter is stored in FIFO buffer 0
- bit 7 **FLTEN8**: Filter 8 Enable bit
 1 = Filter is enabled
 0 = Filter is disabled
- bit 6-5 **MSEL8<1:0>**: Filter 8 Mask Select bits
 11 = Acceptance Mask 3 selected
 10 = Acceptance Mask 2 selected
 01 = Acceptance Mask 1 selected
 00 = Acceptance Mask 0 selected
- bit 4-0 **FSEL8<4:0>**: FIFO Selection bits
 11111 = Message matching filter is stored in FIFO buffer 31
 11110 = Message matching filter is stored in FIFO buffer 30
 •
 •
 •
 00001 = Message matching filter is stored in FIFO buffer 1
 00000 = Message matching filter is stored in FIFO buffer 0

Note: The bits in this register can only be modified if the corresponding filter enable (FLTENn) bit is '0'.

PIC32MZ Embedded Connectivity with Floating Point Unit (EF) Family

REGISTER 29-13: CiFLTCON3: CAN FILTER CONTROL REGISTER 3

| Bit Range | Bit 31/23/15/7 | Bit 30/22/14/6 | Bit 29/21/13/5 | Bit 28/20/12/4 | Bit 27/19/11/3 | Bit 26/18/10/2 | Bit 25/17/9/1 | Bit 24/16/8/0 |
|-----------|----------------|----------------|----------------|----------------|----------------|----------------|---------------|---------------|
| 31:24 | R/W-0 | R/W-0 | R/W-0 | R/W-0 | R/W-0 | R/W-0 | R/W-0 | R/W-0 |
| | FLTEN15 | MSEL15<1:0> | | FSEL15<4:0> | | | | |
| 23:16 | R/W-0 | R/W-0 | R/W-0 | R/W-0 | R/W-0 | R/W-0 | R/W-0 | R/W-0 |
| | FLTEN14 | MSEL14<1:0> | | FSEL14<4:0> | | | | |
| 15:8 | R/W-0 | R/W-0 | R/W-0 | R/W-0 | R/W-0 | R/W-0 | R/W-0 | R/W-0 |
| | FLTEN13 | MSEL13<1:0> | | FSEL13<4:0> | | | | |
| 7:0 | R/W-0 | R/W-0 | R/W-0 | R/W-0 | R/W-0 | R/W-0 | R/W-0 | R/W-0 |
| | FLTEN12 | MSEL12<1:0> | | FSEL12<4:0> | | | | |

Legend:

R = Readable bit W = Writable bit U = Unimplemented bit, read as '0'
 -n = Value at POR '1' = Bit is set '0' = Bit is cleared x = Bit is unknown

bit 31 **FLTEN15:** Filter 15 Enable bit

1 = Filter is enabled
 0 = Filter is disabled

bit 30-29 **MSEL15<1:0>:** Filter 15 Mask Select bits

11 = Acceptance Mask 3 selected
 10 = Acceptance Mask 2 selected
 01 = Acceptance Mask 1 selected
 00 = Acceptance Mask 0 selected

bit 28-24 **FSEL15<4:0>:** FIFO Selection bits

11111 = Message matching filter is stored in FIFO buffer 31
 11110 = Message matching filter is stored in FIFO buffer 30

•
 •
 •

00001 = Message matching filter is stored in FIFO buffer 1
 00000 = Message matching filter is stored in FIFO buffer 0

bit 23 **FLTEN14:** Filter 14 Enable bit

1 = Filter is enabled
 0 = Filter is disabled

bit 22-21 **MSEL14<1:0>:** Filter 14 Mask Select bits

11 = Acceptance Mask 3 selected
 10 = Acceptance Mask 2 selected
 01 = Acceptance Mask 1 selected
 00 = Acceptance Mask 0 selected

bit 20-16 **FSEL14<4:0>:** FIFO Selection bits

11111 = Message matching filter is stored in FIFO buffer 31
 11110 = Message matching filter is stored in FIFO buffer 30

•
 •
 •

00001 = Message matching filter is stored in FIFO buffer 1
 00000 = Message matching filter is stored in FIFO buffer 0

Note: The bits in this register can only be modified if the corresponding filter enable (FLTENn) bit is '0'.

PIC32MZ Embedded Connectivity with Floating Point Unit (EF) Family

REGISTER 29-13: CifLTCON3: CAN FILTER CONTROL REGISTER 3 (CONTINUED)

- bit 15 **FLTEN13**: Filter 13 Enable bit
 1 = Filter is enabled
 0 = Filter is disabled
- bit 14-13 **MSEL13<1:0>**: Filter 13 Mask Select bits
 11 = Acceptance Mask 3 selected
 10 = Acceptance Mask 2 selected
 01 = Acceptance Mask 1 selected
 00 = Acceptance Mask 0 selected
- bit 12-8 **FSEL13<4:0>**: FIFO Selection bits
 11111 = Message matching filter is stored in FIFO buffer 31
 11110 = Message matching filter is stored in FIFO buffer 30
 •
 •
 •
 00001 = Message matching filter is stored in FIFO buffer 1
 00000 = Message matching filter is stored in FIFO buffer 0
- bit 7 **FLTEN12**: Filter 12 Enable bit
 1 = Filter is enabled
 0 = Filter is disabled
- bit 6-5 **MSEL12<1:0>**: Filter 12 Mask Select bits
 11 = Acceptance Mask 3 selected
 10 = Acceptance Mask 2 selected
 01 = Acceptance Mask 1 selected
 00 = Acceptance Mask 0 selected
- bit 4-0 **FSEL12<4:0>**: FIFO Selection bits
 11111 = Message matching filter is stored in FIFO buffer 31
 11110 = Message matching filter is stored in FIFO buffer 30
 •
 •
 •
 00001 = Message matching filter is stored in FIFO buffer 1
 00000 = Message matching filter is stored in FIFO buffer 0

Note: The bits in this register can only be modified if the corresponding filter enable (FLTENn) bit is '0'.

PIC32MZ Embedded Connectivity with Floating Point Unit (EF) Family

REGISTER 29-14: CiFLTCON4: CAN FILTER CONTROL REGISTER 4

| Bit Range | Bit 31/23/15/7 | Bit 30/22/14/6 | Bit 29/21/13/5 | Bit 28/20/12/4 | Bit 27/19/11/3 | Bit 26/18/10/2 | Bit 25/17/9/1 | Bit 24/16/8/0 |
|-----------|----------------|----------------|----------------|----------------|----------------|----------------|---------------|---------------|
| 31:24 | R/W-0 | R/W-0 | R/W-0 | R/W-0 | R/W-0 | R/W-0 | R/W-0 | R/W-0 |
| | FLTEN19 | MSEL19<1:0> | | FSEL19<4:0> | | | | |
| 23:16 | R/W-0 | R/W-0 | R/W-0 | R/W-0 | R/W-0 | R/W-0 | R/W-0 | R/W-0 |
| | FLTEN18 | MSEL18<1:0> | | FSEL18<4:0> | | | | |
| 15:8 | R/W-0 | R/W-0 | R/W-0 | R/W-0 | R/W-0 | R/W-0 | R/W-0 | R/W-0 |
| | FLTEN17 | MSEL17<1:0> | | FSEL17<4:0> | | | | |
| 7:0 | R/W-0 | R/W-0 | R/W-0 | R/W-0 | R/W-0 | R/W-0 | R/W-0 | R/W-0 |
| | FLTEN16 | MSEL16<1:0> | | FSEL16<4:0> | | | | |

Legend:

R = Readable bit W = Writable bit U = Unimplemented bit, read as '0'
 -n = Value at POR '1' = Bit is set '0' = Bit is cleared x = Bit is unknown

bit 31 **FLTEN19:** Filter 19 Enable bit

1 = Filter is enabled
 0 = Filter is disabled

bit 30-29 **MSEL19<1:0>:** Filter 19 Mask Select bits

11 = Acceptance Mask 3 selected
 10 = Acceptance Mask 2 selected
 01 = Acceptance Mask 1 selected
 00 = Acceptance Mask 0 selected

bit 28-24 **FSEL19<4:0>:** FIFO Selection bits

11111 = Message matching filter is stored in FIFO buffer 31
 11110 = Message matching filter is stored in FIFO buffer 30
 •
 •
 •
 00001 = Message matching filter is stored in FIFO buffer 1
 00000 = Message matching filter is stored in FIFO buffer 0

bit 23 **FLTEN18:** Filter 18 Enable bit

1 = Filter is enabled
 0 = Filter is disabled

bit 22-21 **MSEL18<1:0>:** Filter 18 Mask Select bits

11 = Acceptance Mask 3 selected
 10 = Acceptance Mask 2 selected
 01 = Acceptance Mask 1 selected
 00 = Acceptance Mask 0 selected

bit 20-16 **FSEL18<4:0>:** FIFO Selection bits

11111 = Message matching filter is stored in FIFO buffer 31
 11110 = Message matching filter is stored in FIFO buffer 30
 •
 •
 •
 00001 = Message matching filter is stored in FIFO buffer 1
 00000 = Message matching filter is stored in FIFO buffer 0

Note: The bits in this register can only be modified if the corresponding filter enable (FLTENn) bit is '0'.

PIC32MZ Embedded Connectivity with Floating Point Unit (EF) Family

REGISTER 29-14: CIFLTCON4: CAN FILTER CONTROL REGISTER 4 (CONTINUED)

- bit 15 **FLTEN17**: Filter 13 Enable bit
 1 = Filter is enabled
 0 = Filter is disabled
- bit 14-13 **MSEL17<1:0>**: Filter 17 Mask Select bits
 11 = Acceptance Mask 3 selected
 10 = Acceptance Mask 2 selected
 01 = Acceptance Mask 1 selected
 00 = Acceptance Mask 0 selected
- bit 12-8 **FSEL17<4:0>**: FIFO Selection bits
 11111 = Message matching filter is stored in FIFO buffer 31
 11110 = Message matching filter is stored in FIFO buffer 30
 •
 •
 •
 00001 = Message matching filter is stored in FIFO buffer 1
 00000 = Message matching filter is stored in FIFO buffer 0
- bit 7 **FLTEN16**: Filter 16 Enable bit
 1 = Filter is enabled
 0 = Filter is disabled
- bit 6-5 **MSEL16<1:0>**: Filter 16 Mask Select bits
 11 = Acceptance Mask 3 selected
 10 = Acceptance Mask 2 selected
 01 = Acceptance Mask 1 selected
 00 = Acceptance Mask 0 selected
- bit 4-0 **FSEL16<4:0>**: FIFO Selection bits
 11111 = Message matching filter is stored in FIFO buffer 31
 11110 = Message matching filter is stored in FIFO buffer 30
 •
 •
 •
 00001 = Message matching filter is stored in FIFO buffer 1
 00000 = Message matching filter is stored in FIFO buffer 0

Note: The bits in this register can only be modified if the corresponding filter enable (FLTENn) bit is '0'.

PIC32MZ Embedded Connectivity with Floating Point Unit (EF) Family

REGISTER 29-15: CifLTCON5: CAN FILTER CONTROL REGISTER 5

| Bit Range | Bit 31/23/15/7 | Bit 30/22/14/6 | Bit 29/21/13/5 | Bit 28/20/12/4 | Bit 27/19/11/3 | Bit 26/18/10/2 | Bit 25/17/9/1 | Bit 24/16/8/0 |
|-----------|----------------|----------------|----------------|----------------|----------------|----------------|---------------|---------------|
| 31:24 | R/W-0 | R/W-0 | R/W-0 | R/W-0 | R/W-0 | R/W-0 | R/W-0 | R/W-0 |
| | FLTEN23 | MSEL23<1:0> | FSEL23<4:0> | | | | | |
| 23:16 | R/W-0 | R/W-0 | R/W-0 | R/W-0 | R/W-0 | R/W-0 | R/W-0 | R/W-0 |
| | FLTEN22 | MSEL22<1:0> | FSEL22<4:0> | | | | | |
| 15:8 | R/W-0 | R/W-0 | R/W-0 | R/W-0 | R/W-0 | R/W-0 | R/W-0 | R/W-0 |
| | FLTEN21 | MSEL21<1:0> | FSEL21<4:0> | | | | | |
| 7:0 | R/W-0 | R/W-0 | R/W-0 | R/W-0 | R/W-0 | R/W-0 | R/W-0 | R/W-0 |
| | FLTEN20 | MSEL20<1:0> | FSEL20<4:0> | | | | | |

Legend:

R = Readable bit W = Writable bit U = Unimplemented bit, read as '0'
 -n = Value at POR '1' = Bit is set '0' = Bit is cleared x = Bit is unknown

bit 31 **FLTEN23:** Filter 23 Enable bit

1 = Filter is enabled
 0 = Filter is disabled

bit 30-29 **MSEL23<1:0>:** Filter 23 Mask Select bits

11 = Acceptance Mask 3 selected
 10 = Acceptance Mask 2 selected
 01 = Acceptance Mask 1 selected
 00 = Acceptance Mask 0 selected

bit 28-24 **FSEL23<4:0>:** FIFO Selection bits

11111 = Message matching filter is stored in FIFO buffer 31
 11110 = Message matching filter is stored in FIFO buffer 30
 •
 •
 •
 00001 = Message matching filter is stored in FIFO buffer 1
 00000 = Message matching filter is stored in FIFO buffer 0

bit 23 **FLTEN22:** Filter 22 Enable bit

1 = Filter is enabled
 0 = Filter is disabled

bit 22-21 **MSEL22<1:0>:** Filter 22 Mask Select bits

11 = Acceptance Mask 3 selected
 10 = Acceptance Mask 2 selected
 01 = Acceptance Mask 1 selected
 00 = Acceptance Mask 0 selected

bit 20-16 **FSEL22<4:0>:** FIFO Selection bits

11111 = Message matching filter is stored in FIFO buffer 31
 11110 = Message matching filter is stored in FIFO buffer 30
 •
 •
 •
 00001 = Message matching filter is stored in FIFO buffer 1
 00000 = Message matching filter is stored in FIFO buffer 0

Note: The bits in this register can only be modified if the corresponding filter enable (FLTENn) bit is '0'.

PIC32MZ Embedded Connectivity with Floating Point Unit (EF) Family

REGISTER 29-15: CifLTCON5: CAN FILTER CONTROL REGISTER 5 (CONTINUED)

- bit 15 **FLTEN21**: Filter 21 Enable bit
 1 = Filter is enabled
 0 = Filter is disabled
- bit 14-13 **MSEL21<1:0>**: Filter 21 Mask Select bits
 11 = Acceptance Mask 3 selected
 10 = Acceptance Mask 2 selected
 01 = Acceptance Mask 1 selected
 00 = Acceptance Mask 0 selected
- bit 12-8 **FSEL21<4:0>**: FIFO Selection bits
 11111 = Message matching filter is stored in FIFO buffer 31
 11110 = Message matching filter is stored in FIFO buffer 30
 •
 •
 •
 00001 = Message matching filter is stored in FIFO buffer 1
 00000 = Message matching filter is stored in FIFO buffer 0
- bit 7 **FLTEN20**: Filter 20 Enable bit
 1 = Filter is enabled
 0 = Filter is disabled
- bit 6-5 **MSEL20<1:0>**: Filter 20 Mask Select bits
 11 = Acceptance Mask 3 selected
 10 = Acceptance Mask 2 selected
 01 = Acceptance Mask 1 selected
 00 = Acceptance Mask 0 selected
- bit 4-0 **FSEL20<4:0>**: FIFO Selection bits
 11111 = Message matching filter is stored in FIFO buffer 31
 11110 = Message matching filter is stored in FIFO buffer 30
 •
 •
 •
 00001 = Message matching filter is stored in FIFO buffer 1
 00000 = Message matching filter is stored in FIFO buffer 0

Note: The bits in this register can only be modified if the corresponding filter enable (FLTENn) bit is '0'.

PIC32MZ Embedded Connectivity with Floating Point Unit (EF) Family

REGISTER 29-16: CiFLTCON6: CAN FILTER CONTROL REGISTER 6

| Bit Range | Bit 31/23/15/7 | Bit 30/22/14/6 | Bit 29/21/13/5 | Bit 28/20/12/4 | Bit 27/19/11/3 | Bit 26/18/10/2 | Bit 25/17/9/1 | Bit 24/16/8/0 |
|-----------|----------------|----------------|----------------|----------------|----------------|----------------|---------------|---------------|
| 31:24 | R/W-0 | R/W-0 | R/W-0 | R/W-0 | R/W-0 | R/W-0 | R/W-0 | R/W-0 |
| | FLTEN27 | MSEL27<1:0> | | FSEL27<4:0> | | | | |
| 23:16 | R/W-0 | R/W-0 | R/W-0 | R/W-0 | R/W-0 | R/W-0 | R/W-0 | R/W-0 |
| | FLTEN26 | MSEL26<1:0> | | FSEL26<4:0> | | | | |
| 15:8 | R/W-0 | R/W-0 | R/W-0 | R/W-0 | R/W-0 | R/W-0 | R/W-0 | R/W-0 |
| | FLTEN25 | MSEL25<1:0> | | FSEL25<4:0> | | | | |
| 7:0 | R/W-0 | R/W-0 | R/W-0 | R/W-0 | R/W-0 | R/W-0 | R/W-0 | R/W-0 |
| | FLTEN24 | MSEL24<1:0> | | FSEL24<4:0> | | | | |

Legend:

R = Readable bit W = Writable bit U = Unimplemented bit, read as '0'
 -n = Value at POR '1' = Bit is set '0' = Bit is cleared x = Bit is unknown

bit 31 **FLTEN27**: Filter 27 Enable bit

1 = Filter is enabled
 0 = Filter is disabled

bit 30-29 **MSEL27<1:0>**: Filter 27 Mask Select bits

11 = Acceptance Mask 3 selected
 10 = Acceptance Mask 2 selected
 01 = Acceptance Mask 1 selected
 00 = Acceptance Mask 0 selected

bit 28-24 **FSEL27<4:0>**: FIFO Selection bits

11111 = Message matching filter is stored in FIFO buffer 31
 11110 = Message matching filter is stored in FIFO buffer 30
 •
 •
 •
 00001 = Message matching filter is stored in FIFO buffer 1
 00000 = Message matching filter is stored in FIFO buffer 0

bit 23 **FLTEN26**: Filter 26 Enable bit

1 = Filter is enabled
 0 = Filter is disabled

bit 22-21 **MSEL26<1:0>**: Filter 26 Mask Select bits

11 = Acceptance Mask 3 selected
 10 = Acceptance Mask 2 selected
 01 = Acceptance Mask 1 selected
 00 = Acceptance Mask 0 selected

bit 20-16 **FSEL26<4:0>**: FIFO Selection bits

11111 = Message matching filter is stored in FIFO buffer 31
 11110 = Message matching filter is stored in FIFO buffer 30
 •
 •
 •
 00001 = Message matching filter is stored in FIFO buffer 1
 00000 = Message matching filter is stored in FIFO buffer 0

Note: The bits in this register can only be modified if the corresponding filter enable (FLTENn) bit is '0'.

PIC32MZ Embedded Connectivity with Floating Point Unit (EF) Family

REGISTER 29-16: CiFLTCON6: CAN FILTER CONTROL REGISTER 6 (CONTINUED)

- bit 15 **FLTEN25**: Filter 25 Enable bit
 1 = Filter is enabled
 0 = Filter is disabled
- bit 14-13 **MSEL25<1:0>**: Filter 25 Mask Select bits
 11 = Acceptance Mask 3 selected
 10 = Acceptance Mask 2 selected
 01 = Acceptance Mask 1 selected
 00 = Acceptance Mask 0 selected
- bit 12-8 **FSEL25<4:0>**: FIFO Selection bits
 11111 = Message matching filter is stored in FIFO buffer 31
 11110 = Message matching filter is stored in FIFO buffer 30
 •
 •
 •
 00001 = Message matching filter is stored in FIFO buffer 1
 00000 = Message matching filter is stored in FIFO buffer 0
- bit 7 **FLTEN24**: Filter 24 Enable bit
 1 = Filter is enabled
 0 = Filter is disabled
- bit 6-5 **MSEL24<1:0>**: Filter 24 Mask Select bits
 11 = Acceptance Mask 3 selected
 10 = Acceptance Mask 2 selected
 01 = Acceptance Mask 1 selected
 00 = Acceptance Mask 0 selected
- bit 4-0 **FSEL24<4:0>**: FIFO Selection bits
 11111 = Message matching filter is stored in FIFO buffer 31
 11110 = Message matching filter is stored in FIFO buffer 30
 •
 •
 •
 00001 = Message matching filter is stored in FIFO buffer 1
 00000 = Message matching filter is stored in FIFO buffer 0

Note: The bits in this register can only be modified if the corresponding filter enable (FLTENn) bit is '0'.

PIC32MZ Embedded Connectivity with Floating Point Unit (EF) Family

REGISTER 29-17: CiFLTCON7: CAN FILTER CONTROL REGISTER 7

| Bit Range | Bit 31/23/15/7 | Bit 30/22/14/6 | Bit 29/21/13/5 | Bit 28/20/12/4 | Bit 27/19/11/3 | Bit 26/18/10/2 | Bit 25/17/9/1 | Bit 24/16/8/0 |
|-----------|----------------|----------------|----------------|----------------|----------------|----------------|---------------|---------------|
| 31:24 | R/W-0 | R/W-0 | R/W-0 | R/W-0 | R/W-0 | R/W-0 | R/W-0 | R/W-0 |
| | FLTEN31 | MSEL31<1:0> | | FSEL31<4:0> | | | | |
| 23:16 | R/W-0 | R/W-0 | R/W-0 | R/W-0 | R/W-0 | R/W-0 | R/W-0 | R/W-0 |
| | FLTEN30 | MSEL30<1:0> | | FSEL30<4:0> | | | | |
| 15:8 | R/W-0 | R/W-0 | R/W-0 | R/W-0 | R/W-0 | R/W-0 | R/W-0 | R/W-0 |
| | FLTEN29 | MSEL29<1:0> | | FSEL29<4:0> | | | | |
| 7:0 | R/W-0 | R/W-0 | R/W-0 | R/W-0 | R/W-0 | R/W-0 | R/W-0 | R/W-0 |
| | FLTEN28 | MSEL28<1:0> | | FSEL28<4:0> | | | | |

Legend:

R = Readable bit W = Writable bit U = Unimplemented bit, read as '0'
 -n = Value at POR '1' = Bit is set '0' = Bit is cleared x = Bit is unknown

bit 31 **FLTEN31**: Filter 31 Enable bit

1 = Filter is enabled
 0 = Filter is disabled

bit 30-29 **MSEL31<1:0>**: Filter 31 Mask Select bits

11 = Acceptance Mask 3 selected
 10 = Acceptance Mask 2 selected
 01 = Acceptance Mask 1 selected
 00 = Acceptance Mask 0 selected

bit 28-24 **FSEL31<4:0>**: FIFO Selection bits

11111 = Message matching filter is stored in FIFO buffer 31
 11110 = Message matching filter is stored in FIFO buffer 30
 •
 •
 •
 00001 = Message matching filter is stored in FIFO buffer 1
 00000 = Message matching filter is stored in FIFO buffer 0

bit 23 **FLTEN30**: Filter 30 Enable bit

1 = Filter is enabled
 0 = Filter is disabled

bit 22-21 **MSEL30<1:0>**: Filter 30 Mask Select bits

11 = Acceptance Mask 3 selected
 10 = Acceptance Mask 2 selected
 01 = Acceptance Mask 1 selected
 00 = Acceptance Mask 0 selected

bit 20-16 **FSEL30<4:0>**: FIFO Selection bits

11111 = Message matching filter is stored in FIFO buffer 31
 11110 = Message matching filter is stored in FIFO buffer 30
 •
 •
 •
 00001 = Message matching filter is stored in FIFO buffer 1
 00000 = Message matching filter is stored in FIFO buffer 0

Note: The bits in this register can only be modified if the corresponding filter enable (FLTENn) bit is '0'.

PIC32MZ Embedded Connectivity with Floating Point Unit (EF) Family

REGISTER 29-17: CifLTCON7: CAN FILTER CONTROL REGISTER 7 (CONTINUED)

- bit 15 **FLTEN29**: Filter 29 Enable bit
1 = Filter is enabled
0 = Filter is disabled
- bit 14-13 **MSEL29<1:0>**: Filter 29 Mask Select bits
11 = Acceptance Mask 3 selected
10 = Acceptance Mask 2 selected
01 = Acceptance Mask 1 selected
00 = Acceptance Mask 0 selected
- bit 12-8 **FSEL29<4:0>**: FIFO Selection bits
11111 = Message matching filter is stored in FIFO buffer 31
11110 = Message matching filter is stored in FIFO buffer 30
•
•
•
00001 = Message matching filter is stored in FIFO buffer 1
00000 = Message matching filter is stored in FIFO buffer 0
- bit 7 **FLTEN28**: Filter 28 Enable bit
1 = Filter is enabled
0 = Filter is disabled
- bit 6-5 **MSEL28<1:0>**: Filter 28 Mask Select bits
11 = Acceptance Mask 3 selected
10 = Acceptance Mask 2 selected
01 = Acceptance Mask 1 selected
00 = Acceptance Mask 0 selected
- bit 4-0 **FSEL28<4:0>**: FIFO Selection bits
11111 = Message matching filter is stored in FIFO buffer 31
11110 = Message matching filter is stored in FIFO buffer 30
•
•
•
00001 = Message matching filter is stored in FIFO buffer 1
00000 = Message matching filter is stored in FIFO buffer 0

Note: The bits in this register can only be modified if the corresponding filter enable (FLTENn) bit is '0'.

PIC32MZ Embedded Connectivity with Floating Point Unit (EF) Family

REGISTER 29-18: CiRXFn: CAN ACCEPTANCE FILTER 'n' REGISTER 7 ('n' = 0-31)

| Bit Range | Bit 31/23/15/7 | Bit 30/22/14/6 | Bit 29/21/13/5 | Bit 28/20/12/4 | Bit 27/19/11/3 | Bit 26/18/10/2 | Bit 25/17/9/1 | Bit 24/16/8/0 |
|-----------|----------------|----------------|----------------|----------------|----------------|----------------|---------------|---------------|
| 31:24 | R/W-x | R/W-x | R/W-x | R/W-x | R/W-x | R/W-x | R/W-x | R/W-x |
| | SID<10:3> | | | | | | | |
| 23:16 | R/W-x | R/W-x | R/W-x | U-0 | R/W-0 | U-0 | R/W-x | R/W-x |
| | SID<2:0> | | | — | EXID | — | EID<17:16> | |
| 15:8 | R/W-x | R/W-x | R/W-x | R/W-x | R/W-x | R/W-x | R/W-x | R/W-x |
| | EID<15:8> | | | | | | | |
| 7:0 | R/W-x | R/W-x | R/W-x | R/W-x | R/W-x | R/W-x | R/W-x | R/W-x |
| | EID<7:0> | | | | | | | |

Legend:

R = Readable bit W = Writable bit U = Unimplemented bit, read as '0'
-n = Value at POR '1' = Bit is set '0' = Bit is cleared x = Bit is unknown

- bit 31-21 **SID<10:0>**: Standard Identifier bits
1 = Message address bit SIDx must be '1' to match filter
0 = Message address bit SIDx must be '0' to match filter
- bit 20 **Unimplemented**: Read as '0'
- bit 19 **EXID**: Extended Identifier Enable bits
1 = Match only messages with extended identifier addresses
0 = Match only messages with standard identifier addresses
- bit 18 **Unimplemented**: Read as '0'
- bit 17-0 **EID<17:0>**: Extended Identifier bits
1 = Message address bit EIDx must be '1' to match filter
0 = Message address bit EIDx must be '0' to match filter

Note: This register can only be modified when the filter is disabled (FLTENN = 0).

PIC32MZ Embedded Connectivity with Floating Point Unit (EF) Family

REGISTER 29-19: CiFIFOBA: CAN MESSAGE BUFFER BASE ADDRESS REGISTER

| Bit Range | Bit 31/23/15/7 | Bit 30/22/14/6 | Bit 29/21/13/5 | Bit 28/20/12/4 | Bit 27/19/11/3 | Bit 26/18/10/2 | Bit 25/17/9/1 | Bit 24/16/8/0 |
|-----------------|----------------|----------------|----------------|----------------|----------------|----------------|--------------------|--------------------|
| 31:24 | R/W-0 | R/W-0 | R/W-0 | R/W-0 | R/W-0 | R/W-0 | R/W-0 | R/W-0 |
| CiFIFOBA<31:24> | | | | | | | | |
| 23:16 | R/W-0 | R/W-0 | R/W-0 | R/W-0 | R/W-0 | R/W-0 | R/W-0 | R/W-0 |
| CiFIFOBA<23:16> | | | | | | | | |
| 15:8 | R/W-0 | R/W-0 | R/W-0 | R/W-0 | R/W-0 | R/W-0 | R/W-0 | R/W-0 |
| CiFIFOBA<15:8> | | | | | | | | |
| 7:0 | R/W-0 | R/W-0 | R/W-0 | R/W-0 | R/W-0 | R/W-0 | R-0 ⁽¹⁾ | R-0 ⁽¹⁾ |
| CiFIFOBA<7:0> | | | | | | | | |

Legend:

R = Readable bit W = Writable bit U = Unimplemented bit, read as '0'
 -n = Value at POR '1' = Bit is set '0' = Bit is cleared x = Bit is unknown

bit 31-0 **CiFIFOBA<31:0>**: CAN FIFO Base Address bits

These bits define the base address of all message buffers. Individual message buffers are located based on the size of the previous message buffers. This address is a physical address. Note that bits <1:0> are read-only and read '0', forcing the messages to be 32-bit word-aligned in device RAM.

Note 1: This bit is unimplemented and will always read '0', which forces word-alignment of messages.

Note: This register can only be modified when the CAN module is in Configuration mode (OPMOD<2:0> (CiCON<23:21>) = 100).

PIC32MZ Embedded Connectivity with Floating Point Unit (EF) Family

REGISTER 29-20: CiFIFOCONn: CAN FIFO CONTROL REGISTER 'n' ('n' = 0-31)

| Bit Range | Bit 31/23/15/7 | Bit 30/22/14/6 | Bit 29/21/13/5 | Bit 28/20/12/4 | Bit 27/19/11/3 | Bit 26/18/10/2 | Bit 25/17/9/1 | Bit 24/16/8/0 |
|-----------|----------------|-----------------------|-----------------------|---------------------------|----------------|----------------|---------------|---------------|
| 31:24 | U-0 | U-0 | U-0 | U-0 | U-0 | U-0 | U-0 | U-0 |
| | — | — | — | — | — | — | — | — |
| 23:16 | U-0 | U-0 | U-0 | R/W-0 | R/W-0 | R/W-0 | R/W-0 | R/W-0 |
| | — | — | — | FSIZE<4:0> ⁽¹⁾ | | | | |
| 15:8 | U-0 | S/HC-0 | S/HC-0 | R/W-0 | U-0 | U-0 | U-0 | U-0 |
| | — | FRESET | UINC | DONLY ⁽¹⁾ | — | — | — | — |
| 7:0 | R/W-0 | R-0 | R-0 | R-0 | R/W-0 | R/W-0 | R/W-0 | R/W-0 |
| | TXEN | TXABAT ⁽²⁾ | TXLARB ⁽³⁾ | TXERR ⁽³⁾ | TXREQ | RTREN | TXPR<1:0> | |

Legend:

R = Readable bit W = Writable bit U = Unimplemented bit, read as '0'
-n = Value at POR '1' = Bit is set '0' = Bit is cleared x = Bit is unknown

bit 31-21 **Unimplemented:** Read as '0'

bit 20-16 **FSIZE<4:0>:** FIFO Size bits⁽¹⁾

11111 = FIFO is 32 messages deep

-
-
-

00010 = FIFO is 3 messages deep

00001 = FIFO is 2 messages deep

00000 = FIFO is 1 message deep

bit 15 **Unimplemented:** Read as '0'

bit 14 **FRESET:** FIFO Reset bits

1 = FIFO will be reset when bit is set, cleared by hardware when FIFO is reset. After setting, the user should poll if this bit is clear before taking any action

0 = No effect

bit 13 **UINC:** Increment Head/Tail bit

TXEN = 1: (FIFO configured as a Transmit FIFO)

When this bit is set the FIFO head will increment by a single message

TXEN = 0: (FIFO configured as a Receive FIFO)

When this bit is set the FIFO tail will increment by a single message

bit 12 **DONLY:** Store Message Data Only bit⁽¹⁾

TXEN = 1: (FIFO configured as a Transmit FIFO)

This bit is not used and has no effect.

TXEN = 0: (FIFO configured as a Receive FIFO)

1 = Only data bytes will be stored in the FIFO

0 = Full message is stored, including identifier

bit 11-8 **Unimplemented:** Read as '0'

bit 7 **TXEN:** TX/RX Buffer Selection bit

1 = FIFO is a Transmit FIFO

0 = FIFO is a Receive FIFO

Note 1: These bits can only be modified when the CAN module is in Configuration mode (OPMOD<2:0> bits (CiCON<23:21>) = 100).

2: This bit is updated when a message completes (or aborts) or when the FIFO is reset.

3: This bit is reset on any read of this register or when the FIFO is reset.

PIC32MZ Embedded Connectivity with Floating Point Unit (EF) Family

REGISTER 29-20: CiFIFOCONn: CAN FIFO CONTROL REGISTER 'n' ('n' = 0-31) (CONTINUED)

- bit 6 **TXABAT:** Message Aborted bit⁽²⁾
1 = Message was aborted
0 = Message completed successfully
- bit 5 **TXLARB:** Message Lost Arbitration bit⁽³⁾
1 = Message lost arbitration while being sent
0 = Message did not loose arbitration while being sent
- bit 4 **TXERR:** Error Detected During Transmission bit⁽³⁾
1 = A bus error ocured while the message was being sent
0 = A bus error did not occur while the message was being sent
- bit 3 **TXREQ:** Message Send Request
TXEN = 1: (FIFO configured as a Transmit FIFO)
Setting this bit to '1' requests sending a message.
The bit will automatically clear when all the messages queued in the FIFO are successfully sent
Clearing the bit to '0' while set ('1') will request a message abort.
TXEN = 0: (FIFO configured as a Receive FIFO)
This bit has no effect.
- bit 2 **RTREN:** Auto RTR Enable bit
1 = When a remote transmit is received, TXREQ will be set
0 = When a remote transmit is received, TXREQ will be unaffected
- bit 1-0 **TXPR<1:0>:** Message Transmit Priority bits
11 = Highest Message Priority
10 = High Intermediate Message Priority
01 = Low Intermediate Message Priority
00 = Lowest Message Priority

Note 1: These bits can only be modified when the CAN module is in Configuration mode (OPMOD<2:0> bits (CiCON<23:21>) = 100).

2: This bit is updated when a message completes (or aborts) or when the FIFO is reset.

3: This bit is reset on any read of this register or when the FIFO is reset.

PIC32MZ Embedded Connectivity with Floating Point Unit (EF) Family

REGISTER 29-21: CiFIFOINTn: CAN FIFO INTERRUPT REGISTER 'n' ('n' = 0-31)

| Bit Range | Bit 31/23/15/7 | Bit 30/22/14/6 | Bit 29/21/13/5 | Bit 28/20/12/4 | Bit 27/19/11/3 | Bit 26/18/10/2 | Bit 25/17/9/1 | Bit 24/16/8/0 |
|-----------|----------------|----------------|----------------|----------------|----------------|--------------------------|-------------------------|---------------------------|
| 31:24 | U-0 | U-0 | U-0 | U-0 | U-0 | R/W-0 | R/W-0 | R/W-0 |
| | — | — | — | — | — | TXNFULLIE | TXHALFIE | TXEMPTYIE |
| 23:16 | U-0 | U-0 | U-0 | U-0 | R/W-0 | R/W-0 | R/W-0 | R/W-0 |
| | — | — | — | — | RXOVFLIE | RXFULLIE | RXHALFIE | RXNEMPTYIE |
| 15:8 | U-0 | U-0 | U-0 | U-0 | U-0 | R-0 | R-0 | R-0 |
| | — | — | — | — | — | TXNFULLIF ⁽¹⁾ | TXHALFIF | TXEMPTYIF ⁽¹⁾ |
| 7:0 | U-0 | U-0 | U-0 | U-0 | R/W-0 | R-0 | R-0 | R-0 |
| | — | — | — | — | RXOVFLIF | RXFULLIF ⁽¹⁾ | RXHALFIF ⁽¹⁾ | RXNEMPTYIF ⁽¹⁾ |

Legend:

R = Readable bit W = Writable bit U = Unimplemented bit, read as '0'
 -n = Value at POR '1' = Bit is set '0' = Bit is cleared x = Bit is unknown

bit 31-27 **Unimplemented:** Read as '0'

bit 26 **TXNFULLIE:** Transmit FIFO Not Full Interrupt Enable bit
 1 = Interrupt enabled for FIFO not full
 0 = Interrupt disabled for FIFO not full

bit 25 **TXHALFIE:** Transmit FIFO Half Full Interrupt Enable bit
 1 = Interrupt enabled for FIFO half full
 0 = Interrupt disabled for FIFO half full

bit 24 **TXEMPTYIE:** Transmit FIFO Empty Interrupt Enable bit
 1 = Interrupt enabled for FIFO empty
 0 = Interrupt disabled for FIFO empty

bit 23-20 **Unimplemented:** Read as '0'

bit 19 **RXOVFLIE:** Overflow Interrupt Enable bit
 1 = Interrupt enabled for overflow event
 0 = Interrupt disabled for overflow event

bit 18 **RXFULLIE:** Full Interrupt Enable bit
 1 = Interrupt enabled for FIFO full
 0 = Interrupt disabled for FIFO full

bit 17 **RXHALFIE:** FIFO Half Full Interrupt Enable bit
 1 = Interrupt enabled for FIFO half full
 0 = Interrupt disabled for FIFO half full

bit 16 **RXNEMPTYIE:** Empty Interrupt Enable bit
 1 = Interrupt enabled for FIFO not empty
 0 = Interrupt disabled for FIFO not empty

bit 15-11 **Unimplemented:** Read as '0'

bit 10 **TXNFULLIF:** Transmit FIFO Not Full Interrupt Flag bit⁽¹⁾
TXEN = 1: (FIFO configured as a Transmit Buffer)
 1 = FIFO is not full
 0 = FIFO is full
TXEN = 0: (FIFO configured as a Receive Buffer)
 Unused, reads '0'

Note 1: This bit is read-only and reflects the status of the FIFO.

PIC32MZ Embedded Connectivity with Floating Point Unit (EF) Family

REGISTER 29-21: CiFIFOINTn: CAN FIFO INTERRUPT REGISTER 'n' ('n' = 0-31) (CONTINUED)

bit 9 **TXHALFIF**: FIFO Transmit FIFO Half Empty Interrupt Flag bit⁽¹⁾

TXEN = 1: (FIFO configured as a Transmit Buffer)

1 = FIFO is \leq half full

0 = FIFO is $>$ half full

TXEN = 0: (FIFO configured as a Receive Buffer)

Unused, reads '0'

bit 8 **TXEMPTYIF**: Transmit FIFO Empty Interrupt Flag bit⁽¹⁾

TXEN = 1: (FIFO configured as a Transmit Buffer)

1 = FIFO is empty

0 = FIFO is not empty, at least 1 message queued to be transmitted

TXEN = 0: (FIFO configured as a Receive Buffer)

Unused, reads '0'

bit 7-4 **Unimplemented**: Read as '0'

bit 3 **RXOVFLIF**: Receive FIFO Overflow Interrupt Flag bit

TXEN = 1: (FIFO configured as a Transmit Buffer)

Unused, reads '0'

TXEN = 0: (FIFO configured as a Receive Buffer)

1 = Overflow event has occurred

0 = No overflow event occurred

bit 2 **RXFULLIF**: Receive FIFO Full Interrupt Flag bit⁽¹⁾

TXEN = 1: (FIFO configured as a Transmit Buffer)

Unused, reads '0'

TXEN = 0: (FIFO configured as a Receive Buffer)

1 = FIFO is full

0 = FIFO is not full

bit 1 **RXHALFIF**: Receive FIFO Half Full Interrupt Flag bit⁽¹⁾

TXEN = 1: (FIFO configured as a Transmit Buffer)

Unused, reads '0'

TXEN = 0: (FIFO configured as a Receive Buffer)

1 = FIFO is \geq half full

0 = FIFO is $<$ half full

bit 0 **RXEMPTYIF**: Receive Buffer Not Empty Interrupt Flag bit⁽¹⁾

TXEN = 1: (FIFO configured as a Transmit Buffer)

Unused, reads '0'

TXEN = 0: (FIFO configured as a Receive Buffer)

1 = FIFO is not empty, has at least 1 message

0 = FIFO is empty

Note 1: This bit is read-only and reflects the status of the FIFO.

PIC32MZ Embedded Connectivity with Floating Point Unit (EF) Family

REGISTER 29-22: CiFIFOUAn: CAN FIFO USER ADDRESS REGISTER 'n' ('n' = 0-31)

| Bit Range | Bit 31/23/15/7 | Bit 30/22/14/6 | Bit 29/21/13/5 | Bit 28/20/12/4 | Bit 27/19/11/3 | Bit 26/18/10/2 | Bit 25/17/9/1 | Bit 24/16/8/0 |
|------------------|----------------|----------------|----------------|----------------|----------------|----------------|--------------------|--------------------|
| 31:24 | R-x | R-x | R-x | R-x | R-x | R-x | R-x | R-x |
| CiFIFOUAn<31:24> | | | | | | | | |
| 23:16 | R-x | R-x | R-x | R-x | R-x | R-x | R-x | R-x |
| CiFIFOUAn<23:16> | | | | | | | | |
| 15:8 | R-x | R-x | R-x | R-x | R-x | R-x | R-x | R-x |
| CiFIFOUAn<15:8> | | | | | | | | |
| 7:0 | R-x | R-x | R-x | R-x | R-x | R-x | R-0 ⁽¹⁾ | R-0 ⁽¹⁾ |
| CiFIFOUAn<7:0> | | | | | | | | |

Legend:

R = Readable bit W = Writable bit U = Unimplemented bit, read as '0'
 -n = Value at POR '1' = Bit is set '0' = Bit is cleared x = Bit is unknown

bit 31-0 **CiFIFOUAn<31:0>**: CAN FIFO User Address bits

TXEN = 1: (FIFO configured as a Transmit Buffer)

A read of this register will return the address where the next message is to be written (FIFO head).

TXEN = 0: (FIFO configured as a Receive Buffer)

A read of this register will return the address where the next message is to be read (FIFO tail).

Note 1: This bit will always read '0', which forces byte-alignment of messages.

Note: This register is not guaranteed to read correctly in Configuration mode, and should only be accessed when the module is not in Configuration mode.

REGISTER 29-23: CiFIFOCIn: CAN MODULE MESSAGE INDEX REGISTER 'n' ('n' = 0-31)

| Bit Range | Bit 31/23/15/7 | Bit 30/22/14/6 | Bit 29/21/13/5 | Bit 28/20/12/4 | Bit 27/19/11/3 | Bit 26/18/10/2 | Bit 25/17/9/1 | Bit 24/16/8/0 |
|----------------|----------------|----------------|----------------|----------------|----------------|----------------|---------------|---------------|
| 31:24 | U-0 | U-0 | U-0 | U-0 | U-0 | U-0 | U-0 | U-0 |
| — | | | | | | | | |
| 23:16 | U-0 | U-0 | U-0 | U-0 | U-0 | U-0 | U-0 | U-0 |
| — | | | | | | | | |
| 15:8 | U-0 | U-0 | U-0 | U-0 | U-0 | U-0 | U-0 | U-0 |
| — | | | | | | | | |
| 7:0 | U-0 | U-0 | U-0 | R-0 | R-0 | R-0 | R-0 | R-0 |
| CiFIFOCIn<4:0> | | | | | | | | |

Legend:

R = Readable bit W = Writable bit U = Unimplemented bit, read as '0'
 -n = Value at POR '1' = Bit is set '0' = Bit is cleared x = Bit is unknown

bit 31-5 **Unimplemented:** Read as '0'

bit 4-0 **CiFIFOCIn<4:0>**: CAN Side FIFO Message Index bits

TXEN = 1: (FIFO configured as a Transmit Buffer)

A read of this register will return an index to the message that the FIFO will next attempt to transmit.

TXEN = 0: (FIFO configured as a Receive Buffer)

A read of this register will return an index to the message that the FIFO will use to save the next message.

30.0 ETHERNET CONTROLLER

Note: This data sheet summarizes the features of the PIC32MZ EF family of devices. It is not intended to be a comprehensive reference source. To complement the information in this data sheet, refer to **Section 35. “Ethernet Controller”** (DS60001155) in the *“PIC32 Family Reference Manual”*, which is available from the Microchip web site (www.microchip.com/PIC32).

The Ethernet controller is a bus master module that interfaces with an off-chip Physical Layer (PHY) to implement a complete Ethernet node in a system.

Key features of the Ethernet Controller include:

- Supports 10/100 Mbps data transfer rates
- Supports full-duplex and half-duplex operation

- Supports RMI and MII PHY interface
- Supports MIIM PHY management interface
- Supports both manual and automatic Flow Control
- RAM descriptor-based DMA operation for both receive and transmit path
- Fully configurable interrupts
- Configurable receive packet filtering
 - CRC check
 - 64-byte pattern match
 - Broadcast, multicast and unicast packets
 - Magic Packet™
 - 64-bit hash table
 - Runt packet
- Supports packet payload checksum calculation
- Supports various hardware statistics counters

Figure 30-1 illustrates a block diagram of the Ethernet controller.

FIGURE 30-1: ETHERNET CONTROLLER BLOCK DIAGRAM

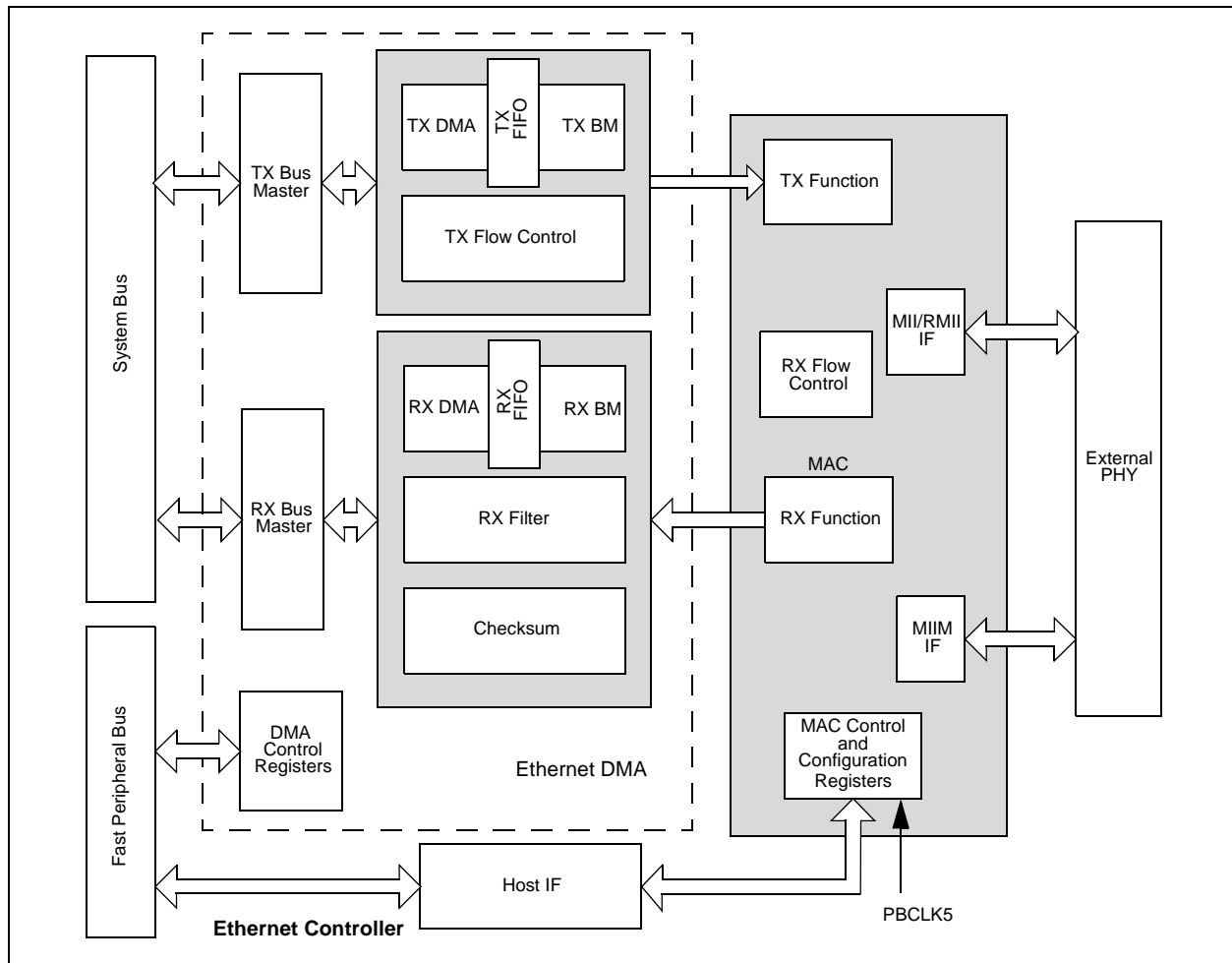

PIC32MZ Embedded Connectivity with Floating Point Unit (EF) Family

Table 30-1, Table 30-2, Table 30-3 and Table 30-4 show four interfaces and the associated pins that can be used with the Ethernet Controller.

TABLE 30-1: MII MODE DEFAULT INTERFACE SIGNALS (FMIEN = 1, FETHIO = 1)

| Pin Name | Description |
|----------|----------------------|
| EMDC | Management Clock |
| EMDIO | Management I/O |
| ETXCLK | Transmit Clock |
| ETXEN | Transmit Enable |
| ETXD0 | Transmit Data |
| ETXD1 | Transmit Data |
| ETXD2 | Transmit Data |
| ETXD3 | Transmit Data |
| ETXERR | Transmit Error |
| ERXCLK | Receive Clock |
| ERXDV | Receive Data Valid |
| ERXD0 | Receive Data |
| ERXD1 | Receive Data |
| ERXD2 | Receive Data |
| ERXD3 | Receive Data |
| ERXERR | Receive Error |
| ECRS | Carrier Sense |
| ECOL | Collision Indication |

TABLE 30-2: RMII MODE DEFAULT INTERFACE SIGNALS (FMIEN = 0, FETHIO = 1)

| Pin Name | Description |
|----------|------------------------------------|
| EMDC | Management Clock |
| EMDIO | Management I/O |
| ETXEN | Transmit Enable |
| ETXD0 | Transmit Data |
| ETXD1 | Transmit Data |
| EREFCLK | Reference Clock |
| ECRSDV | Carrier Sense – Receive Data Valid |
| ERXD0 | Receive Data |
| ERXD1 | Receive Data |
| ERXERR | Receive Error |

Note: Ethernet controller pins that are not used by selected interface can be used by other peripherals.

TABLE 30-3: MII MODE ALTERNATE INTERFACE SIGNALS (FMIEN = 1, FETHIO = 0)

| Pin Name | Description |
|----------|----------------------|
| AEMDC | Management Clock |
| AEMDIO | Management I/O |
| AETXCLK | Transmit Clock |
| AETXEN | Transmit Enable |
| AETXD0 | Transmit Data |
| AETXD1 | Transmit Data |
| AETXD2 | Transmit Data |
| AETXD3 | Transmit Data |
| AETXERR | Transmit Error |
| AERXCLK | Receive Clock |
| AERXDV | Receive Data Valid |
| AERXD0 | Receive Data |
| AERXD1 | Receive Data |
| AERXD2 | Receive Data |
| AERXD3 | Receive Data |
| AERXERR | Receive Error |
| AECRS | Carrier Sense |
| AECOL | Collision Indication |

Note: The MII mode Alternate Interface is not available on 64-pin devices.

TABLE 30-4: RMII MODE ALTERNATE INTERFACE SIGNALS (FMIEN = 0, FETHIO = 0)

| Pin Name | Description |
|----------|------------------------------------|
| AEMDC | Management Clock |
| AEMDIO | Management I/O |
| AETXEN | Transmit Enable |
| AETXD0 | Transmit Data |
| AETXD1 | Transmit Data |
| AEREFCLK | Reference Clock |
| AECRSDV | Carrier Sense – Receive Data Valid |
| AERXD0 | Receive Data |
| AERXD1 | Receive Data |
| AERXERR | Receive Error |

30.1 Ethernet Control Registers

TABLE 30-5: ETHERNET CONTROLLER REGISTER SUMMARY

| Virtual Address (BF88_#) | Register Name ⁽¹⁾ | Bit Range | Bits | | | | | | | | | | | | | | All Resets | | |
|-----------------------------|---------------------------------|-----------|------------------|--------------|--------------|-------|-------------|-------|--------------|--------------|--------------|---------------|---------------|--------|--------------|---------------|---------------|---------------|---------|
| | | | 31/15 | 30/14 | 29/13 | 28/12 | 27/11 | 26/10 | 25/9 | 24/8 | 23/7 | 22/6 | 21/5 | 20/4 | 19/3 | 18/2 | | 17/1 | 16/0 |
| 2000 | ETHCON1 | 31:16 | PTV<15:0> | | | | | | | | | | | | | | 0000 | | |
| | | 15:0 | ON | — | SIDL | — | — | — | TXRTS | RXEN | AUTOFC | — | — | MANFC | — | — | — | — | BUFCDEC |
| 2010 | ETHCON2 | 31:16 | — | — | — | — | — | — | — | — | — | — | — | — | — | — | — | — | 0000 |
| | | 15:0 | — | — | — | — | — | — | RXBUFSZ<6:0> | | | | | | | — | — | — | — |
| 2020 | ETHXST | 31:16 | TXSTADDR<31:16> | | | | | | | | | | | | | | 0000 | | |
| | | 15:0 | TXSTADDR<15:2> | | | | | | | | | | | | — | — | 0000 | | |
| 2030 | ETHRXST | 31:16 | RXSTADDR<31:16> | | | | | | | | | | | | | | 0000 | | |
| | | 15:0 | RXSTADDR<15:2> | | | | | | | | | | | | — | — | 0000 | | |
| 2040 | ETHHT0 | 31:16 | HT<31:0> | | | | | | | | | | | | | | 0000 | | |
| | | 15:0 | | | | | | | | | | | | | | | 0000 | | |
| 2050 | ETHHT1 | 31:16 | HT<63:32> | | | | | | | | | | | | | | 0000 | | |
| | | 15:0 | | | | | | | | | | | | | | | 0000 | | |
| 2060 | ETHPMM0 | 31:16 | PMM<31:0> | | | | | | | | | | | | | | 0000 | | |
| | | 15:0 | | | | | | | | | | | | | | | 0000 | | |
| 2070 | ETHPMM1 | 31:16 | PMM<63:32> | | | | | | | | | | | | | | 0000 | | |
| | | 15:0 | | | | | | | | | | | | | | | 0000 | | |
| 2080 | ETHPMCS | 31:16 | — | — | — | — | — | — | — | — | — | — | — | — | — | — | — | — | 0000 |
| | | 15:0 | PMCS<15:0> | | | | | | | | | | | | | | 0000 | | |
| 2090 | ETHPMO | 31:16 | — | — | — | — | — | — | — | — | — | — | — | — | — | — | — | — | 0000 |
| | | 15:0 | PMO<15:0> | | | | | | | | | | | | | | 0000 | | |
| 20A0 | ETHRXFC | 31:16 | — | — | — | — | — | — | — | — | — | — | — | — | — | — | — | — | 0000 |
| | | 15:0 | HTEN | MPEN | — | NOTPM | PMMODE<3:0> | | | | CRC ERREN | CRC OKEN | RUNT ERREN | RUNTEN | UCEN | NOT MEEN | MCEN | BCEN | 0000 |
| 20B0 | ETHRXWM | 31:16 | — | — | — | — | — | — | — | RXFWM<7:0> | | | | | | | 0000 | | |
| | | 15:0 | — | — | — | — | — | — | — | RXEWM<7:0> | | | | | | | 0000 | | |
| 20C0 | ETHIEN | 31:16 | — | — | — | — | — | — | — | — | — | — | — | — | — | — | — | — | 0000 |
| | | 15:0 | — | TX BUSEIE | RX BUSEIE | — | — | — | EW MARKIE | FW MARKIE | RX DONEIE | PK TPENDIE | RX ACTIE | — | TX DONEIE | TX ABORTIE | RX BUFNAIE | RX OVFLWIE | 0000 |
| 20D0 | ETHIRQ | 31:16 | — | — | — | — | — | — | — | — | — | — | — | — | — | — | — | — | 0000 |
| | | 15:0 | — | TXBUSE | RXBUSE | — | — | — | EWMARK | FWMARK | RXDONE | PKTPEND | RXACT | — | TXDONE | TXABORT | RXBUFNA | RXOVFLW | 0000 |
| 20E0 | ETHSTAT | 31:16 | — | — | — | — | — | — | — | — | BUFCNT<7:0> | | | | | | | 0000 | |
| | | 15:0 | — | — | — | — | — | — | — | BUSY | TXBUSY | RXBUSY | — | — | — | — | — | — | 0000 |
| 2100 | ETH RXOVFLOW | 31:16 | — | — | — | — | — | — | — | — | — | — | — | — | — | — | — | — | 0000 |
| | | 15:0 | RXOVFLWCNT<15:0> | | | | | | | | | | | | | | 0000 | | |

Legend: x = unknown value on Reset; — = unimplemented, read as '0'. Reset values are shown in hexadecimal.

Note 1: All registers in this table (with the exception of ETHSTAT) have corresponding CLR, SET and INV registers at their virtual addresses, plus offsets of 0x4, 0x8 and 0xC, respectively. See [Section 12.3 "CLR, SET, and INV Registers"](#) for more information.

2: Reset values default to the factory programmed value.

TABLE 30-5: ETHERNET CONTROLLER REGISTER SUMMARY (CONTINUED)

| Virtual Address (BF88_#) | Register Name ⁽¹⁾ | Bit Range | Bits | | | | | | | | | | | | | | | All Resets | |
|-----------------------------|---------------------------------|-----------|------------------|---------------|---------------|---------|---------------|---------------|------------------|---------------|---------|-------------|---------------|---------------|----------|---------|----------|------------|----------|
| | | | 31/15 | 30/14 | 29/13 | 28/12 | 27/11 | 26/10 | 25/9 | 24/8 | 23/7 | 22/6 | 21/5 | 20/4 | 19/3 | 18/2 | 17/1 | | 16/0 |
| 2110 | ETH FRMTXOK | 31:16 | — | — | — | — | — | — | — | — | — | — | — | — | — | — | — | — | 0000 |
| | | 15:0 | FRMTXOKCNT<15:0> | | | | | | | | | | | | | | | 0000 | |
| 2120 | ETH SCOLFRM | 31:16 | — | — | — | — | — | — | — | — | — | — | — | — | — | — | — | — | 0000 |
| | | 15:0 | SCOLFRMCNT<15:0> | | | | | | | | | | | | | | | 0000 | |
| 2130 | ETH MCOLFRM | 31:16 | — | — | — | — | — | — | — | — | — | — | — | — | — | — | — | — | 0000 |
| | | 15:0 | MCOLFRMCNT<15:0> | | | | | | | | | | | | | | | 0000 | |
| 2140 | ETH FRMRXOK | 31:16 | — | — | — | — | — | — | — | — | — | — | — | — | — | — | — | — | 0000 |
| | | 15:0 | FRMRXOKCNT<15:0> | | | | | | | | | | | | | | | 0000 | |
| 2150 | ETH FCSERR | 31:16 | — | — | — | — | — | — | — | — | — | — | — | — | — | — | — | — | 0000 |
| | | 15:0 | FCSERRCNT<15:0> | | | | | | | | | | | | | | | 0000 | |
| 2160 | ETH ALGNERR | 31:16 | — | — | — | — | — | — | — | — | — | — | — | — | — | — | — | — | 0000 |
| | | 15:0 | ALGNERRCNT<15:0> | | | | | | | | | | | | | | | 0000 | |
| 2200 | EMAC1 CFG1 | 31:16 | — | — | — | — | — | — | — | — | — | — | — | — | — | — | — | — | 0000 |
| | | 15:0 | SOFT RESET | SIM RESET | — | — | RESET RMCS | RESET RFUN | RESET TMCS | RESET TFUN | — | — | — | — | LOOPBACK | TXPAUSE | RXPAUSE | PASSALL | RXENABLE |
| 2210 | EMAC1 CFG2 | 31:16 | — | — | — | — | — | — | — | — | — | — | — | — | — | — | — | — | 0000 |
| | | 15:0 | — | EXCESS DFR | BP NOBKOFF | NOBKOFF | — | — | LONGPRE | PUREPRE | AUTOPAD | VLANPAD | PAD ENABLE | CRC ENABLE | DELAYCRC | HUGEFRM | LENGTHCK | FULLDPLX | 4082 |
| 2220 | EMAC1 IPGT | 31:16 | — | — | — | — | — | — | — | — | — | — | — | — | — | — | — | — | 0000 |
| | | 15:0 | B2BIPKTGP<6:0> | | | | | | | | | | | | | | | 0012 | |
| 2230 | EMAC1 IPGR | 31:16 | — | — | — | — | — | — | — | — | — | — | — | — | — | — | — | — | 0000 |
| | | 15:0 | NB2BIPKTGP1<6:0> | | | | | — | NB2BIPKTGP2<6:0> | | | | | 0C12 | | | | | |
| 2240 | EMAC1 CLRT | 31:16 | — | — | — | — | — | — | — | — | — | — | — | — | — | — | — | — | 0000 |
| | | 15:0 | CWINDOW<5:0> | | | | | — | — | | | | | RETX<3:0> | | | | | 370F |
| 2250 | EMAC1 MAXF | 31:16 | — | — | — | — | — | — | — | — | — | — | — | — | — | — | — | — | 0000 |
| | | 15:0 | MACMAXF<15:0> | | | | | | | | | | | | | | | 05EE | |
| 2260 | EMAC1 SUPP | 31:16 | — | — | — | — | — | — | — | — | — | — | — | — | — | — | — | — | 0000 |
| | | 15:0 | — | — | — | — | RESET RMII | — | — | SPEED RMII | — | — | — | — | — | — | — | — | 1000 |
| 2270 | EMAC1 TEST | 31:16 | — | — | — | — | — | — | — | — | — | — | — | — | — | — | — | — | 0000 |
| | | 15:0 | — | — | — | — | — | — | — | — | — | — | — | — | — | — | TESTBP | TESTPAUSE | SHRTQNTA |
| 2280 | EMAC1 MCFG | 31:16 | — | — | — | — | — | — | — | — | — | — | — | — | — | — | — | — | 0000 |
| | | 15:0 | RESET MGMT | — | — | — | — | — | — | — | — | CLKSEL<3:0> | | | | | NOPRE | SCANINC | 0020 |
| 2290 | EMAC1 MCMD | 31:16 | — | — | — | — | — | — | — | — | — | — | — | — | — | — | — | — | 0000 |
| | | 15:0 | — | — | — | — | — | — | — | — | — | — | — | — | — | — | — | SCAN | READ |
| 22A0 | EMAC1 MADR | 31:16 | — | — | — | — | — | — | — | — | — | — | — | — | — | — | — | — | 0000 |
| | | 15:0 | PHYADDR<4:0> | | | | | — | — | | | | | REGADDR<4:0> | | | | | 0100 |

Legend: x = unknown value on Reset; — = unimplemented, read as '0'. Reset values are shown in hexadecimal.

Note 1: All registers in this table (with the exception of ETHSTAT) have corresponding CLR, SET and INV registers at their virtual addresses, plus offsets of 0x4, 0x8 and 0xC, respectively. See Section 12.3 "CLR, SET, and INV Registers" for more information.

Note 2: Reset values default to the factory programmed value.

TABLE 30-5: ETHERNET CONTROLLER REGISTER SUMMARY (CONTINUED)

| Virtual Address (BF88_#) | Register Name ⁽¹⁾ | Bit Range | Bits | | | | | | | | | | | | | | All Resets | | |
|--------------------------|------------------------------|-----------|---------------|-------|-------|-------|-------|-------|------|---------------|------|------|------|------|----------|----------|------------|----------|------|
| | | | 31/15 | 30/14 | 29/13 | 28/12 | 27/11 | 26/10 | 25/9 | 24/8 | 23/7 | 22/6 | 21/5 | 20/4 | 19/3 | 18/2 | | 17/1 | 16/0 |
| 22B0 | EMAC1 MWTD | 31:16 | — | — | — | — | — | — | — | — | — | — | — | — | — | — | — | — | 0000 |
| | | 15:0 | MWTD<15:0> | | | | | | | | | | | | | | 0000 | | |
| 22C0 | EMAC1 MRDD | 31:16 | — | — | — | — | — | — | — | — | — | — | — | — | — | — | — | — | 0000 |
| | | 15:0 | MRDD<15:0> | | | | | | | | | | | | | | 0000 | | |
| 22D0 | EMAC1 MIND | 31:16 | — | — | — | — | — | — | — | — | — | — | — | — | — | — | — | — | 0000 |
| | | 15:0 | — | — | — | — | — | — | — | — | — | — | — | — | LINKFAIL | NOTVALID | SCAN | MIIMBUSY | 0000 |
| 2300 | EMAC1 SA0 ⁽²⁾ | 31:16 | — | — | — | — | — | — | — | — | — | — | — | — | — | — | — | — | xxxx |
| | | 15:0 | STNADDR6<7:0> | | | | | | | STNADDR5<7:0> | | | | | | | xxxx | | |
| 2310 | EMAC1 SA1 ⁽²⁾ | 31:16 | — | — | — | — | — | — | — | — | — | — | — | — | — | — | — | — | xxxx |
| | | 15:0 | STNADDR4<7:0> | | | | | | | STNADDR3<7:0> | | | | | | | xxxx | | |
| 2320 | EMAC1 SA2 ⁽²⁾ | 31:16 | — | — | — | — | — | — | — | — | — | — | — | — | — | — | — | — | xxxx |
| | | 15:0 | STNADDR2<7:0> | | | | | | | STNADDR1<7:0> | | | | | | | xxxx | | |

Legend: x = unknown value on Reset; — = unimplemented, read as '0'. Reset values are shown in hexadecimal.
Note 1: All registers in this table (with the exception of ETHSTAT) have corresponding CLR, SET and INV registers at their virtual addresses, plus offsets of 0x4, 0x8 and 0xC, respectively. See [Section 12.3 “CLR, SET, and INV Registers”](#) for more information.
 2: Reset values default to the factory programmed value.

PIC32MZ Embedded Connectivity with Floating Point Unit (EF) Family

REGISTER 30-1: ETHCON1: ETHERNET CONTROLLER CONTROL REGISTER 1

| Bit Range | Bit 31/23/15/7 | Bit 30/22/14/6 | Bit 29/21/13/5 | Bit 28/20/12/4 | Bit 27/19/11/3 | Bit 26/18/10/2 | Bit 25/17/9/1 | Bit 24/16/8/0 |
|-----------|-------------------|-------------------|-------------------|-------------------|-------------------|-------------------|------------------|---------------------|
| 31:24 | R/W-0 | R/W-0 | R/W-0 | R/W-0 | R/W-0 | R/W-0 | R/W-0 | R/W-0 |
| | PTV<15:8> | | | | | | | |
| 23:16 | R/W-0 | R/W-0 | R/W-0 | R/W-0 | R/W-0 | R/W-0 | R/W-0 | R/W-0 |
| | PTV<7:0> | | | | | | | |
| 15:8 | R/W-0 | U-0 | R/W-0 | U-0 | U-0 | U-0 | R/W-0 | R/W-0 |
| | ON | — | SIDL | — | — | — | TXRTS | RXEN ⁽¹⁾ |
| 7:0 | R/W-0 | U-0 | U-0 | R/W-0 | U-0 | U-0 | U-0 | R/W-0 |
| | AUTOFC | — | — | MANFC | — | — | — | BUFCDEC |

Legend:

R = Readable bit W = Writable bit U = Unimplemented bit, read as '0'
 -n = Value at POR '1' = Bit is set '0' = Bit is cleared x = Bit is unknown

- bit 31-16 **PTV<15:0>**: PAUSE Timer Value bits
 PAUSE Timer Value used for Flow Control.
 This register should only be written when RXEN (ETHCON1<8>) is not set.
 These bits are only used for Flow Control operations.
- bit 15 **ON**: Ethernet ON bit
 1 = Ethernet module is enabled
 0 = Ethernet module is disabled
- bit 14 **Unimplemented**: Read as '0'
- bit 13 **SIDL**: Ethernet Stop in Idle Mode bit
 1 = Ethernet module transfers are paused during Idle mode
 0 = Ethernet module transfers continue during Idle mode
- bit 12-10 **Unimplemented**: Read as '0'
- bit 9 **TXRTS**: Transmit Request to Send bit
 1 = Activate the TX logic and send the packet(s) defined in the TX EDT
 0 = Stop transmit (when cleared by software) or transmit done (when cleared by hardware)
 After the bit is written with a '1', it will clear to a '0' whenever the transmit logic has finished transmitting the requested packets in the Ethernet Descriptor Table (EDT). If a '0' is written by the CPU, the transmit logic finishes the current packet's transmission and then stops any further.
 This bit only affects TX operations.
- bit 8 **RXEN**: Receive Enable bit⁽¹⁾
 1 = Enable RX logic, packets are received and stored in the RX buffer as controlled by the filter configuration
 0 = Disable RX logic, no packets are received in the RX buffer
 This bit only affects RX operations.

Note 1: It is not recommended to clear the RXEN bit and then make changes to any RX related field/register. The Ethernet Controller must be reinitialized (ON cleared to '0'), and then the RX changes applied.

PIC32MZ Embedded Connectivity with Floating Point Unit (EF) Family

REGISTER 30-1: ETHCON1: ETHERNET CONTROLLER CONTROL REGISTER 1 (CONTINUED)

bit 7 **AUTOFC:** Automatic Flow Control bit

1 = Automatic Flow Control enabled
0 = Automatic Flow Control disabled

Setting this bit will enable automatic Flow Control. If set, the full and empty watermarks are used to automatically enable and disable the Flow Control, respectively. When the number of received buffers BUFCNT (ETHSTAT<16:23>) rises to the full watermark, Flow Control is automatically enabled. When the BUFCNT falls to the empty watermark, Flow Control is automatically disabled.

This bit is only used for Flow Control operations and affects both TX and RX operations.

bit 6-5 **Unimplemented:** Read as '0'

bit 4 **MANFC:** Manual Flow Control bit

1 = Manual Flow Control is enabled
0 = Manual Flow Control is disabled

Setting this bit will enable manual Flow Control. If set, the Flow Control logic will send a PAUSE frame using the PAUSE timer value in the PTV register. It will then resend a PAUSE frame every $128 * PTV<15:0>/2$ TX clock cycles until the bit is cleared.

Note: For 10 Mbps operation, TX clock runs at 2.5 MHz. For 100 Mbps operation, TX clock runs at 25 MHz.

When this bit is cleared, the Flow Control logic will automatically send a PAUSE frame with a 0x0000 PAUSE timer value to disable Flow Control.

This bit is only used for Flow Control operations and affects both TX and RX operations.

bit 3-1 **Unimplemented:** Read as '0'

bit 0 **BUFCDEC:** Descriptor Buffer Count Decrement bit

The BUFCDEC bit is a write-1 bit that reads as '0'. When written with a '1', the Descriptor Buffer Counter, BUFCNT, will decrement by one. If BUFCNT is incremented by the RX logic at the same time that this bit is written, the BUFCNT value will remain unchanged. Writing a '0' will have no effect.

This bit is only used for RX operations.

Note 1: It is not recommended to clear the RXEN bit and then make changes to any RX related field/register. The Ethernet Controller must be reinitialized (ON cleared to '0'), and then the RX changes applied.

PIC32MZ Embedded Connectivity with Floating Point Unit (EF) Family

REGISTER 30-2: ETHCON2: ETHERNET CONTROLLER CONTROL REGISTER 2

| Bit Range | Bit 31/23/15/7 | Bit 30/22/14/6 | Bit 29/21/13/5 | Bit 28/20/12/4 | Bit 27/19/11/3 | Bit 26/18/10/2 | Bit 25/17/9/1 | Bit 24/16/8/0 |
|-----------|-------------------|-------------------|-------------------|-------------------|-------------------|-------------------|------------------|------------------|
| 31:24 | U-0 | U-0 | U-0 | U-0 | U-0 | U-0 | U-0 | U-0 |
| | — | — | — | — | — | — | — | — |
| 23:16 | U-0 | U-0 | U-0 | U-0 | U-0 | U-0 | U-0 | U-0 |
| | — | — | — | — | — | — | — | — |
| 15:8 | U-0 | U-0 | U-0 | U-0 | U-0 | R/W-0 | R/W-0 | R/W-0 |
| | — | — | — | — | — | RXBUFSZ<6:4> | | |
| 7:0 | R/W-0 | R/W-0 | R/W-0 | R/W-0 | U-0 | U-0 | U-0 | U-0 |
| | RXBUFSZ<3:0> | | | | — | — | — | — |

Legend:

R = Readable bit W = Writable bit U = Unimplemented bit, read as '0'
-n = Value at POR '1' = Bit is set '0' = Bit is cleared x = Bit is unknown

bit 31-11 **Unimplemented:** Read as '0'

bit 10-4 **RXBUFSZ<6:0>:** RX Data Buffer Size for All RX Descriptors (in 16-byte increments) bits

1111111 = RX data Buffer size for descriptors is 2032 bytes

•

•

•

1100000 = RX data Buffer size for descriptors is 1536 bytes

•

•

•

0000011 = RX data Buffer size for descriptors is 48 bytes

0000010 = RX data Buffer size for descriptors is 32 bytes

0000001 = RX data Buffer size for descriptors is 16 bytes

0000000 = Reserved

bit 3-0 **Unimplemented:** Read as '0'

Note 1: This register is only used for RX operations.

Note 2: The bits in this register may only be changed while the RXEN bit (ETHCON1<8>) = 0.

PIC32MZ Embedded Connectivity with Floating Point Unit (EF) Family

REGISTER 30-5: ETHHT0: ETHERNET CONTROLLER HASH TABLE 0 REGISTER

| Bit Range | Bit 31/23/15/7 | Bit 30/22/14/6 | Bit 29/21/13/5 | Bit 28/20/12/4 | Bit 27/19/11/3 | Bit 26/18/10/2 | Bit 25/17/9/1 | Bit 24/16/8/0 |
|-----------|----------------|----------------|----------------|----------------|----------------|----------------|---------------|---------------|
| 31:24 | R/W-0 | R/W-0 | R/W-0 | R/W-0 | R/W-0 | R/W-0 | R/W-0 | R/W-0 |
| | HT<31:24> | | | | | | | |
| 23:16 | R/W-0 | R/W-0 | R/W-0 | R/W-0 | R/W-0 | R/W-0 | R/W-0 | R/W-0 |
| | HT<23:16> | | | | | | | |
| 15:8 | R/W-0 | R/W-0 | R/W-0 | R/W-0 | R/W-0 | R/W-0 | R/W-0 | R/W-0 |
| | HT<15:8> | | | | | | | |
| 7:0 | R/W-0 | R/W-0 | R/W-0 | R/W-0 | R/W-0 | R/W-0 | R/W-0 | R/W-0 |
| | HT<7:0> | | | | | | | |

Legend:

R = Readable bit W = Writable bit U = Unimplemented bit, read as '0'
-n = Value at POR '1' = Bit is set '0' = Bit is cleared x = Bit is unknown

bit 31-0 **HT<31:0>**: Hash Table Bytes 0-3 bits

Note 1: This register is only used for RX operations.
Note 2: The bits in this register may only be changed while the RXEN bit (ETHCON1<8>) = 0 or the HTEN bit (ETHRXFC<15>) = 0.

REGISTER 30-6: ETHHT1: ETHERNET CONTROLLER HASH TABLE 1 REGISTER

| Bit Range | Bit 31/23/15/7 | Bit 30/22/14/6 | Bit 29/21/13/5 | Bit 28/20/12/4 | Bit 27/19/11/3 | Bit 26/18/10/2 | Bit 25/17/9/1 | Bit 24/16/8/0 |
|-----------|----------------|----------------|----------------|----------------|----------------|----------------|---------------|---------------|
| 31:24 | R/W-0 | R/W-0 | R/W-0 | R/W-0 | R/W-0 | R/W-0 | R/W-0 | R/W-0 |
| | HT<63:56> | | | | | | | |
| 23:16 | R/W-0 | R/W-0 | R/W-0 | R/W-0 | R/W-0 | R/W-0 | R/W-0 | R/W-0 |
| | HT<55:48> | | | | | | | |
| 15:8 | R/W-0 | R/W-0 | R/W-0 | R/W-0 | R/W-0 | R/W-0 | R/W-0 | R/W-0 |
| | HT<47:40> | | | | | | | |
| 7:0 | R/W-0 | R/W-0 | R/W-0 | R/W-0 | R/W-0 | R/W-0 | R/W-0 | R/W-0 |
| | HT<39:32> | | | | | | | |

Legend:

R = Readable bit W = Writable bit U = Unimplemented bit, read as '0'
-n = Value at POR '1' = Bit is set '0' = Bit is cleared x = Bit is unknown

bit 31-0 **HT<63:32>**: Hash Table Bytes 4-7 bits

Note 1: This register is only used for RX operations.
Note 2: The bits in this register may only be changed while the RXEN bit (ETHCON1<8>) = 0 or the HTEN bit (ETHRXFC<15>) = 0.

PIC32MZ Embedded Connectivity with Floating Point Unit (EF) Family

REGISTER 30-9: ETHPMCS: ETHERNET CONTROLLER PATTERN MATCH CHECKSUM REGISTER

| Bit Range | Bit 31/23/15/7 | Bit 30/22/14/6 | Bit 29/21/13/5 | Bit 28/20/12/4 | Bit 27/19/11/3 | Bit 26/18/10/2 | Bit 25/17/9/1 | Bit 24/16/8/0 |
|-----------|-------------------|-------------------|-------------------|-------------------|-------------------|-------------------|------------------|------------------|
| 31:24 | U-0 | U-0 | U-0 | U-0 | U-0 | U-0 | U-0 | U-0 |
| | — | — | — | — | — | — | — | — |
| 23:16 | U-0 | U-0 | U-0 | U-0 | U-0 | U-0 | U-0 | U-0 |
| | — | — | — | — | — | — | — | — |
| 15:8 | R/W-0 | R/W-0 | R/W-0 | R/W-0 | R/W-0 | R/W-0 | R/W-0 | R/W-0 |
| | PMCS<15:8> | | | | | | | |
| 7:0 | R/W-0 | R/W-0 | R/W-0 | R/W-0 | R/W-0 | R/W-0 | R/W-0 | R/W-0 |
| | PMCS<7:0> | | | | | | | |

Legend:

R = Readable bit W = Writable bit U = Unimplemented bit, read as '0'
 -n = Value at POR '1' = Bit is set '0' = Bit is cleared x = Bit is unknown

bit 31-16 **Unimplemented:** Read as '0'
 bit 15-8 **PMCS<15:8>:** Pattern Match Checksum 1 bits
 bit 7-0 **PMCS<7:0>:** Pattern Match Checksum 0 bits

Note 1: This register is only used for RX operations.
Note 2: The bits in this register may only be changed while the RXEN bit (ETHCON1<8>) = 0 or the PMMODE bit (ETHRXFC<11:8>) = 0.

REGISTER 30-10: ETHPMO: ETHERNET CONTROLLER PATTERN MATCH OFFSET REGISTER

| Bit Range | Bit 31/23/15/7 | Bit 30/22/14/6 | Bit 29/21/13/5 | Bit 28/20/12/4 | Bit 27/19/11/3 | Bit 26/18/10/2 | Bit 25/17/9/1 | Bit 24/16/8/0 |
|-----------|-------------------|-------------------|-------------------|-------------------|-------------------|-------------------|------------------|------------------|
| 31:24 | U-0 | U-0 | U-0 | U-0 | U-0 | U-0 | U-0 | U-0 |
| | — | — | — | — | — | — | — | — |
| 23:16 | U-0 | U-0 | U-0 | U-0 | U-0 | U-0 | U-0 | U-0 |
| | — | — | — | — | — | — | — | — |
| 15:8 | R/W-0 | R/W-0 | R/W-0 | R/W-0 | R/W-0 | R/W-0 | R/W-0 | R/W-0 |
| | PMO<15:8> | | | | | | | |
| 7:0 | R/W-0 | R/W-0 | R/W-0 | R/W-0 | R/W-0 | R/W-0 | R/W-0 | R/W-0 |
| | PMO<7:0> | | | | | | | |

Legend:

R = Readable bit W = Writable bit U = Unimplemented bit, read as '0'
 -n = Value at POR '1' = Bit is set '0' = Bit is cleared x = Bit is unknown

bit 31-16 **Unimplemented:** Read as '0'
 bit 15-0 **PMO<15:0>:** Pattern Match Offset 1 bits

Note 1: This register is only used for RX operations.
Note 2: The bits in this register may only be changed while the RXEN bit (ETHCON1<8>) = 0 or the PMMODE bit (ETHRXFC<11:8>) = 0.

PIC32MZ Embedded Connectivity with Floating Point Unit (EF) Family

REGISTER 30-11: ETHRXFC: ETHERNET CONTROLLER RECEIVE FILTER CONFIGURATION REGISTER (CONTINUED)

- bit 7 **CR CERREN:** CRC Error Collection Enable bit
1 = The received packet CRC must be invalid for the packet to be accepted
0 = Disable CRC Error Collection filtering
This bit allows the user to collect all packets that have an invalid CRC.
- bit 6 **CR COKEN:** CRC OK Enable bit
1 = The received packet CRC must be valid for the packet to be accepted
0 = Disable CRC filtering
This bit allows the user to reject all packets that have an invalid CRC.
- bit 5 **RUNTERREN:** Runt Error Collection Enable bit
1 = The received packet must be a runt packet for the packet to be accepted
0 = Disable Runt Error Collection filtering
This bit allows the user to collect all packets that are runt packets. For this filter, a runt packet is defined as any packet with a size of less than 64 bytes (when CR COKEN = 0) or any packet with a size of less than 64 bytes that has a valid CRC (when CR COKEN = 1).
- bit 4 **RUNTEN:** Runt Enable bit
1 = The received packet must not be a runt packet for the packet to be accepted
0 = Disable Runt filtering
This bit allows the user to reject all runt packets. For this filter, a runt packet is defined as any packet with a size of less than 64 bytes.
- bit 3 **UCEN:** Unicast Enable bit
1 = Enable Unicast Filtering
0 = Disable Unicast Filtering
This bit allows the user to accept all unicast packets whose Destination Address matches the Station Address.
- bit 2 **NOTMEEN:** Not Me Unicast Enable bit
1 = Enable Not Me Unicast Filtering
0 = Disable Not Me Unicast Filtering
This bit allows the user to accept all unicast packets whose Destination Address does not match the Station Address.
- bit 1 **MCEN:** Multicast Enable bit
1 = Enable Multicast Filtering
0 = Disable Multicast Filtering
This bit allows the user to accept all Multicast Address packets.
- bit 0 **BCEN:** Broadcast Enable bit
1 = Enable Broadcast Filtering
0 = Disable Broadcast Filtering
This bit allows the user to accept all Broadcast Address packets.

- Note 1:** XOR = True when either one or the other conditions are true, but not both.
Note 2: This Hash Table Filter match is active regardless of the value of the HTEN bit.
Note 3: This Magic Packet Filter match is active regardless of the value of the MPEN bit.

- | |
|---|
| <p>Note 1: This register is only used for RX operations. Note 2: The bits in this register may only be changed while the RXEN bit (ETHCON1<8>) = 0.</p> |
|---|

PIC32MZ Embedded Connectivity with Floating Point Unit (EF) Family

REGISTER 30-12: ETHRXWM: ETHERNET CONTROLLER RECEIVE WATERMARKS REGISTER

| Bit Range | Bit 31/23/15/7 | Bit 30/22/14/6 | Bit 29/21/13/5 | Bit 28/20/12/4 | Bit 27/19/11/3 | Bit 26/18/10/2 | Bit 25/17/9/1 | Bit 24/16/8/0 |
|-----------|-------------------|-------------------|-------------------|-------------------|-------------------|-------------------|------------------|------------------|
| 31:24 | U-0 | U-0 | U-0 | U-0 | U-0 | U-0 | U-0 | U-0 |
| | — | — | — | — | — | — | — | — |
| 23:16 | R/W-0 | R/W-0 | R/W-0 | R/W-0 | R/W-0 | R/W-0 | R/W-0 | R/W-0 |
| | RXFWM<7:0> | | | | | | | |
| 15:8 | U-0 | U-0 | U-0 | U-0 | U-0 | U-0 | U-0 | U-0 |
| | — | — | — | — | — | — | — | — |
| 7:0 | R/W-0 | R/W-0 | R/W-0 | R/W-0 | R/W-0 | R/W-0 | R/W-0 | R/W-0 |
| | RXEWM<7:0> | | | | | | | |

Legend:

R = Readable bit

W = Writable bit

U = Unimplemented bit, read as '0'

-n = Value at POR

'1' = Bit is set

'0' = Bit is cleared

x = Bit is unknown

bit 31-24 **Unimplemented:** Read as '0'

bit 23-16 **RXFWM<7:0>:** Receive Full Watermark bits

The software controlled RX Buffer Full Watermark Pointer is compared against the RX BUFCNT to determine the full watermark condition for the FWMARK interrupt and for enabling Flow Control when automatic Flow Control is enabled. The Full Watermark Pointer should always be greater than the Empty Watermark Pointer.

bit 15-8 **Unimplemented:** Read as '0'

bit 7-0 **RXEWM<7:0>:** Receive Empty Watermark bits

The software controlled RX Buffer Empty Watermark Pointer is compared against the RX BUFCNT to determine the empty watermark condition for the EWMARK interrupt and for disabling Flow Control when automatic Flow Control is enabled. The Empty Watermark Pointer should always be less than the Full Watermark Pointer.

Note: This register is only used for RX operations.

PIC32MZ Embedded Connectivity with Floating Point Unit (EF) Family

REGISTER 30-13: ETHIEN: ETHERNET CONTROLLER INTERRUPT ENABLE REGISTER

| Bit Range | Bit 31/23/15/7 | Bit 30/22/14/6 | Bit 29/21/13/5 | Bit 28/20/12/4 | Bit 27/19/11/3 | Bit 26/18/10/2 | Bit 25/17/9/1 | Bit 24/16/8/0 |
|-----------|-------------------------|--------------------------|-------------------------|----------------|-------------------------|--------------------------|--------------------------|--------------------------|
| 31:24 | U-0 | U-0 | U-0 | U-0 | U-0 | U-0 | U-0 | U-0 |
| | — | — | — | — | — | — | — | — |
| 23:16 | U-0 | U-0 | U-0 | U-0 | U-0 | U-0 | U-0 | U-0 |
| | — | — | — | — | — | — | — | — |
| 15:8 | U-0 | RW-0 | RW-0 | U-0 | U-0 | U-0 | RW-0 | RW-0 |
| | — | TXBUSEIE ⁽¹⁾ | RXBUSEIE ⁽²⁾ | — | — | — | EWMARKIE ⁽²⁾ | FWMARKIE ⁽²⁾ |
| 7:0 | RW-0 | RW-0 | RW-0 | U-0 | RW-0 | RW-0 | RW-0 | RW-0 |
| | RXDONEIE ⁽²⁾ | PKTPENDIE ⁽²⁾ | RXACTIE ⁽²⁾ | — | TXDONEIE ⁽¹⁾ | TXABORTIE ⁽¹⁾ | RXBUFNAIE ⁽²⁾ | RXOVFLWIE ⁽²⁾ |

Legend:

R = Readable bit

W = Writable bit

U = Unimplemented bit, read as '0'

-n = Value at POR

'1' = Bit is set

'0' = Bit is cleared

x = Bit is unknown

bit 31-15 **Unimplemented:** Read as '0'

bit 14 **TXBUSEIE:** Transmit BVCI Bus Error Interrupt Enable bit⁽¹⁾

1 = Enable TXBUS Error Interrupt

0 = Disable TXBUS Error Interrupt

bit 13 **RXBUSEIE:** Receive BVCI Bus Error Interrupt Enable bit⁽²⁾

1 = Enable RXBUS Error Interrupt

0 = Disable RXBUS Error Interrupt

bit 12-10 **Unimplemented:** Read as '0'

bit 9 **EWMARKIE:** Empty Watermark Interrupt Enable bit⁽²⁾

1 = Enable EWMARK Interrupt

0 = Disable EWMARK Interrupt

bit 8 **FWMARKIE:** Full Watermark Interrupt Enable bit⁽²⁾

1 = Enable FWMARK Interrupt

0 = Disable FWMARK Interrupt

bit 7 **RXDONEIE:** Receiver Done Interrupt Enable bit⁽²⁾

1 = Enable RXDONE Interrupt

0 = Disable RXDONE Interrupt

bit 6 **PKTPENDIE:** Packet Pending Interrupt Enable bit⁽²⁾

1 = Enable PKTPEND Interrupt

0 = Disable PKTPEND Interrupt

bit 5 **RXACTIE:** RX Activity Interrupt Enable bit

1 = Enable RXACT Interrupt

0 = Disable RXACT Interrupt

bit 4 **Unimplemented:** Read as '0'

bit 3 **TXDONEIE:** Transmitter Done Interrupt Enable bit⁽¹⁾

1 = Enable TXDONE Interrupt

0 = Disable TXDONE Interrupt

bit 2 **TXABORTIE:** Transmitter Abort Interrupt Enable bit⁽¹⁾

1 = Enable TXABORT Interrupt

0 = Disable TXABORT Interrupt

bit 1 **RXBUFNAIE:** Receive Buffer Not Available Interrupt Enable bit⁽²⁾

1 = Enable RXBUFNA Interrupt

0 = Disable RXBUFNA Interrupt

bit 0 **RXOVFLWIE:** Receive FIFO Overflow Interrupt Enable bit⁽²⁾

1 = Enable RXOVFLW Interrupt

0 = Disable RXOVFLW Interrupt

Note 1: This bit is only used for TX operations.

Note 2: This bit is only used for RX operations.

PIC32MZ Embedded Connectivity with Floating Point Unit (EF) Family

REGISTER 30-14: ETHIRQ: ETHERNET CONTROLLER INTERRUPT REQUEST REGISTER

| Bit Range | Bit 31/23/15/7 | Bit 30/22/14/6 | Bit 29/21/13/5 | Bit 28/20/12/4 | Bit 27/19/11/3 | Bit 26/18/10/2 | Bit 25/17/9/1 | Bit 24/16/8/0 |
|-----------|-------------------|-------------------|-------------------|-------------------|-------------------|-------------------|------------------|------------------|
| 31:24 | U-0 | U-0 | U-0 | U-0 | U-0 | U-0 | U-0 | U-0 |
| | — | — | — | — | — | — | — | — |
| 23:16 | U-0 | U-0 | U-0 | U-0 | U-0 | U-0 | U-0 | U-0 |
| | — | — | — | — | — | — | — | — |
| 15:8 | U-0 | R/W-0 | R/W-0 | U-0 | U-0 | U-0 | R/W-0 | R/W-0 |
| | — | TXBUSE | RXBUSE | — | — | — | EWMARK | FWMARK |
| 7:0 | R/W-0 | R/W-0 | R/W-0 | U-0 | R/W-0 | R/W-0 | R/W-0 | R/W-0 |
| | RXDONE | PKTPEND | RXACT | — | TXDONE | TXABORT | RXBUFNA | RXOVFLW |

Legend:

R = Readable bit
-n = Value at POR

W = Writable bit
'1' = Bit is set

U = Unimplemented bit, read as '0'
'0' = Bit is cleared
x = Bit is unknown

bit 31-15 **Unimplemented:** Read as '0'

bit 14 **TXBUSE:** Transmit BVCI Bus Error Interrupt bit⁽²⁾

1 = BVCI Bus Error has occurred
0 = BVCI Bus Error has not occurred

This bit is set when the TX DMA encounters a BVCI Bus error during a memory access. It is cleared by either a Reset or CPU write of a '1' to the CLR register.

bit 13 **RXBUSE:** Receive BVCI Bus Error Interrupt bit⁽²⁾

1 = BVCI Bus Error has occurred
0 = BVCI Bus Error has not occurred

This bit is set when the RX DMA encounters a BVCI Bus error during a memory access. It is cleared by either a Reset or CPU write of a '1' to the CLR register.

bit 12-10 **Unimplemented:** Read as '0'

bit 9 **EWMARK:** Empty Watermark Interrupt bit⁽²⁾

1 = Empty Watermark pointer reached
0 = No interrupt pending

This bit is set when the RX Descriptor Buffer Count is less than or equal to the value in the RXEWM bit (ETHRXWM<0:7>) value. It is cleared by BUF CNT bit (ETHSTAT<16:23>) being incremented by hardware. Writing a '0' or a '1' has no effect.

bit 8 **FWMARK:** Full Watermark Interrupt bit⁽²⁾

1 = Full Watermark pointer reached
0 = No interrupt pending

This bit is set when the RX Descriptor Buffer Count is greater than or equal to the value in the RXFWM bit (ETHRXWM<16:23>) field. It is cleared by writing the BUF CDEC (ETHCON1<0>) bit to decrement the BUF CNT counter. Writing a '0' or a '1' has no effect.

Note 1: This bit is only used for TX operations.

Note 2: This bit is are only used for RX operations.

Note: It is recommended to use the SET, CLR, or INV registers to set or clear any bit in this register. Setting or clearing any bits in this register should only be done for debug/test purposes.

PIC32MZ Embedded Connectivity with Floating Point Unit (EF) Family

REGISTER 30-14: ETHIRQ: ETHERNET CONTROLLER INTERRUPT REQUEST REGISTER

| | |
|-------|--|
| bit 7 | RXDONE: Receive Done Interrupt bit ⁽²⁾ 1 = RX packet was successfully received 0 = No interrupt pending This bit is set whenever an RX packet is successfully received. It is cleared by either a Reset or CPU write of a '1' to the CLR register. |
| bit 6 | PKTPEND: Packet Pending Interrupt bit ⁽²⁾ 1 = RX packet pending in memory 0 = RX packet is not pending in memory This bit is set when the BUFCNT counter has a value other than '0'. It is cleared by either a Reset or by writing the BUFCDEC bit to decrement the BUFCNT counter. Writing a '0' or a '1' has no effect. |
| bit 5 | RXACT: Receive Activity Interrupt bit ⁽²⁾ 1 = RX packet data was successfully received 0 = No interrupt pending This bit is set whenever RX packet data is stored in the RXBM FIFO. It is cleared by either a Reset or CPU write of a '1' to the CLR register. |
| bit 4 | Unimplemented: Read as '0' |
| bit 3 | TXDONE: Transmit Done Interrupt bit ⁽²⁾ 1 = TX packet was successfully sent 0 = No interrupt pending This bit is set when the currently transmitted TX packet completes transmission, and the Transmit Status Vector is loaded into the first descriptor used for the packet. It is cleared by either a Reset or CPU write of a '1' to the CLR register. |
| bit 2 | TXABORT: Transmit Abort Condition Interrupt bit ⁽²⁾ 1 = TX abort condition occurred on the last TX packet 0 = No interrupt pending This bit is set when the MAC aborts the transmission of a TX packet for one of the following reasons: <ul style="list-style-type: none">• Jumbo TX packet abort• Underrun abort• Excessive defer abort• Late collision abort• Excessive collisions abort This bit is cleared by either a Reset or CPU write of a '1' to the CLR register. |
| bit 1 | RXBUFNA: Receive Buffer Not Available Interrupt bit ⁽²⁾ 1 = RX Buffer Descriptor Not Available condition has occurred 0 = No interrupt pending This bit is set by a RX Buffer Descriptor Overrun condition. It is cleared by either a Reset or a CPU write of a '1' to the CLR register. |
| bit 0 | RXOVFLW: Receive FIFO Over Flow Error bit ⁽²⁾ 1 = RX FIFO Overflow Error condition has occurred 0 = No interrupt pending RXOVFLW is set by the RXBM Logic for an RX FIFO Overflow condition. It is cleared by either a Reset or CPU write of a '1' to the CLR register. |

Note 1: This bit is only used for TX operations.

Note 2: This bit is are only used for RX operations.

Note: It is recommended to use the SET, CLR, or INV registers to set or clear any bit in this register. Setting or clearing any bits in this register should only be done for debug/test purposes.

PIC32MZ Embedded Connectivity with Floating Point Unit (EF) Family

REGISTER 30-15: ETHSTAT: ETHERNET CONTROLLER STATUS REGISTER

| Bit Range | Bit 31/23/15/7 | Bit 30/22/14/6 | Bit 29/21/13/5 | Bit 28/20/12/4 | Bit 27/19/11/3 | Bit 26/18/10/2 | Bit 25/17/9/1 | Bit 24/16/8/0 |
|-----------|----------------------------|-------------------------|-------------------------|----------------|----------------|----------------|---------------|---------------|
| 31:24 | U-0 | U-0 | U-0 | U-0 | U-0 | U-0 | U-0 | U-0 |
| | — | — | — | — | — | — | — | — |
| 23:16 | R/W-0 | R/W-0 | R/W-0 | R/W-0 | R/W-0 | R/W-0 | R/W-0 | R/W-0 |
| | BUFCNT<7:0> ⁽¹⁾ | | | | | | | |
| 15:8 | U-0 | U-0 | U-0 | U-0 | U-0 | U-0 | U-0 | U-0 |
| | — | — | — | — | — | — | — | — |
| 7:0 | R/W-0 | R/W-0 | R/W-0 | U-0 | U-0 | U-0 | U-0 | U-0 |
| | ETHBUSY ⁽⁵⁾ | TXBUSY ^(2,6) | RXBUSY ^(3,6) | — | — | — | — | — |

Legend:

R = Readable bit

W = Writable bit

U = Unimplemented bit, read as '0'

-n = Value at POR

'1' = Bit is set

'0' = Bit is cleared

x = Bit is unknown

bit 31-24 **Unimplemented:** Read as '0'

bit 23-16 **BUFCNT<7:0>:** Packet Buffer Count bits⁽¹⁾

Number of packet buffers received in memory. Once a packet has been successfully received, this register is incremented by hardware based on the number of descriptors used by the packet. Software decrements the counter (by writing to the BUFCDEC bit (ETHCON1<0>)) for each descriptor used) after a packet has been read out of the buffer. The register does not roll over (0xFF to 0x00) when hardware tries to increment the register and the register is already at 0xFF. Conversely, the register does not roll under (0x00 to 0xFF) when software tries to decrement the register and the register is already at 0x0000. When software attempts to decrement the counter at the same time that the hardware attempts to increment the counter, the counter value will remain unchanged.

When this register value reaches 0xFF, the RX logic will halt (only if automatic Flow Control is enabled) awaiting software to write the BUFCDEC bit in order to decrement the register below 0xFF.

If automatic Flow Control is disabled, the RXDMA will continue processing and the BUFCNT will saturate at a value of 0xFF.

When this register is non-zero, the PKTPEND status bit will be set and an interrupt may be generated, depending on the value of the ETHIEN bit <PKTPENDIE> register.

When the ETHRXST register is written, the BUFCNT counter is automatically cleared to 0x00.

Note: BUFCNT will not be cleared when ON is set to '0'. This enables software to continue to utilize and decrement this count.

bit 15-8 **Unimplemented:** Read as '0'

bit 7 **ETHBUSY:** Ethernet Module busy bit⁽⁵⁾

1 = Ethernet logic has been turned on (ON (ETHCON1<15>) = 1) or is completing a transaction

0 = Ethernet logic is idle

This bit indicates that the module has been turned on or is completing a transaction after being turned off.

Note 1: This bit is only used for RX operations.

2: This bit is only affected by TX operations.

3: This bit is only affected by RX operations.

4: This bit is affected by TX and RX operations.

5: This bit will be *set* when the ON bit (ETHCON1<15>) = 1.

6: This bit will be *cleared* when the ON bit (ETHCON1<15>) = 0.

PIC32MZ Embedded Connectivity with Floating Point Unit (EF) Family

REGISTER 30-15: ETHSTAT: ETHERNET CONTROLLER STATUS REGISTER (CONTINUED)

bit 6 **TXBUSY:** Transmit Busy bit^(2,6)

1 = TX logic is receiving data
0 = TX logic is idle

This bit indicates that a packet is currently being transmitted. A change in this status bit is not necessarily reflected by the TXDONE interrupt, as TX packets may be aborted or rejected by the MAC.

bit 5 **RXBUSY:** Receive Busy bit^(3,6)

1 = RX logic is receiving data
0 = RX logic is idle

This bit indicates that a packet is currently being received. A change in this status bit is not necessarily reflected by the RXDONE interrupt, as RX packets may be aborted or rejected by the RX filter.

bit 4-0 **Unimplemented:** Read as '0'

- Note 1:** This bit is only used for RX operations.
2: This bit is only affected by TX operations.
3: This bit is only affected by RX operations.
4: This bit is affected by TX and RX operations.
5: This bit will be *set* when the ON bit (ETHCON1<15>) = 1.
6: This bit will be *cleared* when the ON bit (ETHCON1<15>) = 0.

PIC32MZ Embedded Connectivity with Floating Point Unit (EF) Family

REGISTER 30-16: ETHRXOVFLOW: ETHERNET CONTROLLER RECEIVE OVERFLOW STATISTICS REGISTER

| Bit Range | Bit 31/23/15/7 | Bit 30/22/14/6 | Bit 29/21/13/5 | Bit 28/20/12/4 | Bit 27/19/11/3 | Bit 26/18/10/2 | Bit 25/17/9/1 | Bit 24/16/8/0 |
|-----------|------------------|----------------|----------------|----------------|----------------|----------------|---------------|---------------|
| 31:24 | U-0 | U-0 | U-0 | U-0 | U-0 | U-0 | U-0 | U-0 |
| | — | — | — | — | — | — | — | — |
| 23:16 | U-0 | U-0 | U-0 | U-0 | U-0 | U-0 | U-0 | U-0 |
| | — | — | — | — | — | — | — | — |
| 15:8 | R/W-0 | R/W-0 | R/W-0 | R/W-0 | R/W-0 | R/W-0 | R/W-0 | R/W-0 |
| | RXOVFLWCNT<15:8> | | | | | | | |
| 7:0 | R/W-0 | R/W-0 | R/W-0 | R/W-0 | R/W-0 | R/W-0 | R/W-0 | R/W-0 |
| | RXOVFLWCNT<7:0> | | | | | | | |

Legend:

R = Readable bit
-n = Value at POR

W = Writable bit
'1' = Bit is set

U = Unimplemented bit, read as '0'
'0' = Bit is cleared
x = Bit is unknown

bit 31-16 **Unimplemented:** Read as '0'

bit 15-0 **RXOVFLWCNT<15:0>:** Dropped Receive Frames Count bits

Increment counter for frames accepted by the RX filter and subsequently dropped due to internal receive error (RXFIFO overrun). This event also sets the RXOVFLW bit (ETHIRQ<0>) interrupt flag.

Note 1: This register is only used for RX operations.

2: This register is automatically cleared by hardware after a read operation, unless the byte enables for bytes 0/1 are '0'.

3: It is recommended to use the SET, CLR, or INV registers to set or clear any bit in this register. Setting or clearing any bits in this register should only be done for debug/test purposes.

PIC32MZ Embedded Connectivity with Floating Point Unit (EF) Family

REGISTER 30-17: ETHFRMTXOK: ETHERNET CONTROLLER FRAMES TRANSMITTED OK STATISTICS REGISTER

| Bit Range | Bit 31/23/15/7 | Bit 30/22/14/6 | Bit 29/21/13/5 | Bit 28/20/12/4 | Bit 27/19/11/3 | Bit 26/18/10/2 | Bit 25/17/9/1 | Bit 24/16/8/0 |
|-----------|------------------|----------------|----------------|----------------|----------------|----------------|---------------|---------------|
| 31:24 | U-0 | U-0 | U-0 | U-0 | U-0 | U-0 | U-0 | U-0 |
| | — | — | — | — | — | — | — | — |
| 23:16 | U-0 | U-0 | U-0 | U-0 | U-0 | U-0 | U-0 | U-0 |
| | — | — | — | — | — | — | — | — |
| 15:8 | R/W-0 | R/W-0 | R/W-0 | R/W-0 | R/W-0 | R/W-0 | R/W-0 | R/W-0 |
| | FRMTXOKCNT<15:8> | | | | | | | |
| 7:0 | R/W-0 | R/W-0 | R/W-0 | R/W-0 | R/W-0 | R/W-0 | R/W-0 | R/W-0 |
| | FRMTXOKCNT<7:0> | | | | | | | |

Legend:

R = Readable bit W = Writable bit U = Unimplemented bit, read as '0'
 -n = Value at POR '1' = Bit is set '0' = Bit is cleared x = Bit is unknown

bit 31-16 **Unimplemented:** Read as '0'

bit 15-0 **FRMTXOKCNT<15:0>:** Frame Transmitted OK Count bits
 Increment counter for frames successfully transmitted.

- Note 1:** This register is only used for TX operations.
- 2:** This register is automatically cleared by hardware after a read operation, unless the byte enables for bytes 0/1 are '0'.
- 3:** It is recommended to use the SET, CLR, or INV registers to set or clear any bit in this register. Setting or clearing any bits in this register should only be done for debug/test purposes.

PIC32MZ Embedded Connectivity with Floating Point Unit (EF) Family

REGISTER 30-18: ETHSCOLFRM: ETHERNET CONTROLLER SINGLE COLLISION FRAMES STATISTICS REGISTER

| Bit Range | Bit 31/23/15/7 | Bit 30/22/14/6 | Bit 29/21/13/5 | Bit 28/20/12/4 | Bit 27/19/11/3 | Bit 26/18/10/2 | Bit 25/17/9/1 | Bit 24/16/8/0 |
|-----------|-------------------|-------------------|-------------------|-------------------|-------------------|-------------------|------------------|------------------|
| 31:24 | U-0 | U-0 | U-0 | U-0 | U-0 | U-0 | U-0 | U-0 |
| | — | — | — | — | — | — | — | — |
| 23:16 | U-0 | U-0 | U-0 | U-0 | U-0 | U-0 | U-0 | U-0 |
| | — | — | — | — | — | — | — | — |
| 15:8 | R/W-0 | R/W-0 | R/W-0 | R/W-0 | R/W-0 | R/W-0 | R/W-0 | R/W-0 |
| | SCOLFRMCNT<15:8> | | | | | | | |
| 7:0 | R/W-0 | R/W-0 | R/W-0 | R/W-0 | R/W-0 | R/W-0 | R/W-0 | R/W-0 |
| | SCOLFRMCNT<7:0> | | | | | | | |

Legend:

R = Readable bit
-n = Value at POR

W = Writable bit
'1' = Bit is set

U = Unimplemented bit, read as '0'
'0' = Bit is cleared
x = Bit is unknown

bit 31-16 **Unimplemented:** Read as '0'

bit 15-0 **SCOLFRMCNT<15:0>:** Single Collision Frame Count bits
Increment count for frames that were successfully transmitted on the second try.

Note 1: This register is only used for TX operations.

2: This register is automatically cleared by hardware after a read operation, unless the byte enables for bytes 0/1 are '0'.

3: It is recommended to use the SET, CLR, or INV registers to set or clear any bit in this register. Setting or clearing any bits in this register should only be done for debug/test purposes.

PIC32MZ Embedded Connectivity with Floating Point Unit (EF) Family

REGISTER 30-19: ETHMCOLFRM: ETHERNET CONTROLLER MULTIPLE COLLISION FRAMES STATISTICS REGISTER

| Bit Range | Bit 31/23/15/7 | Bit 30/22/14/6 | Bit 29/21/13/5 | Bit 28/20/12/4 | Bit 27/19/11/3 | Bit 26/18/10/2 | Bit 25/17/9/1 | Bit 24/16/8/0 |
|-----------|------------------|----------------|----------------|----------------|----------------|----------------|---------------|---------------|
| 31:24 | U-0 | U-0 | U-0 | U-0 | U-0 | U-0 | U-0 | U-0 |
| | — | — | — | — | — | — | — | — |
| 23:16 | U-0 | U-0 | U-0 | U-0 | U-0 | U-0 | U-0 | U-0 |
| | — | — | — | — | — | — | — | — |
| 15:8 | R/W-0 | R/W-0 | R/W-0 | R/W-0 | R/W-0 | R/W-0 | R/W-0 | R/W-0 |
| | MCOLFRMCNT<15:8> | | | | | | | |
| 7:0 | R/W-0 | R/W-0 | R/W-0 | R/W-0 | R/W-0 | R/W-0 | R/W-0 | R/W-0 |
| | MCOLFRMCNT<7:0> | | | | | | | |

Legend:

R = Readable bit W = Writable bit U = Unimplemented bit, read as '0'
 -n = Value at POR '1' = Bit is set '0' = Bit is cleared x = Bit is unknown

bit 31-16 **Unimplemented:** Read as '0'

bit 15-0 **MCOLFRMCNT<15:0>:** Multiple Collision Frame Count bits

Increment count for frames that were successfully transmitted after there was more than one collision.

- Note 1:** This register is only used for TX operations.
- Note 2:** This register is automatically cleared by hardware after a read operation, unless the byte enables for bytes 0/1 are '0'.
- Note 3:** It is recommended to use the SET, CLR, or INV registers to set or clear any bit in this register. Setting or clearing any bits in this register should only be done for debug/test purposes.

PIC32MZ Embedded Connectivity with Floating Point Unit (EF) Family

REGISTER 30-20: ETHFRMRXOK: ETHERNET CONTROLLER FRAMES RECEIVED OK STATISTICS REGISTER

| Bit Range | Bit 31/23/15/7 | Bit 30/22/14/6 | Bit 29/21/13/5 | Bit 28/20/12/4 | Bit 27/19/11/3 | Bit 26/18/10/2 | Bit 25/17/9/1 | Bit 24/16/8/0 |
|-----------|------------------|----------------|----------------|----------------|----------------|----------------|---------------|---------------|
| 31:24 | U-0 | U-0 | U-0 | U-0 | U-0 | U-0 | U-0 | U-0 |
| | — | — | — | — | — | — | — | — |
| 23:16 | U-0 | U-0 | U-0 | U-0 | U-0 | U-0 | U-0 | U-0 |
| | — | — | — | — | — | — | — | — |
| 15:8 | R/W-0 | R/W-0 | R/W-0 | R/W-0 | R/W-0 | R/W-0 | R/W-0 | R/W-0 |
| | FRMRXOKCNT<15:8> | | | | | | | |
| 7:0 | R/W-0 | R/W-0 | R/W-0 | R/W-0 | R/W-0 | R/W-0 | R/W-0 | R/W-0 |
| | FRMRXOKCNT<7:0> | | | | | | | |

Legend:

R = Readable bit
-n = Value at POR

W = Writable bit
'1' = Bit is set

U = Unimplemented bit, read as '0'
'0' = Bit is cleared
x = Bit is unknown

bit 31-16 **Unimplemented:** Read as '0'

bit 15-0 **FRMRXOKCNT<15:0>:** Frames Received OK Count bits

Increment count for frames received successfully by the RX Filter. This count will not be incremented if there is a Frame Check Sequence (FCS) or Alignment error.

Note 1: This register is only used for RX operations.

2: This register is automatically cleared by hardware after a read operation, unless the byte enables for bytes 0/1 are '0'.

3: It is recommended to use the SET, CLR, or INV registers to set or clear any bit in this register. Setting or clearing any bits in this register should only be done for debug/test purposes.

PIC32MZ Embedded Connectivity with Floating Point Unit (EF) Family

REGISTER 30-21: ETHFCSERR: ETHERNET CONTROLLER FRAME CHECK SEQUENCE ERROR STATISTICS REGISTER

| Bit Range | Bit 31/23/15/7 | Bit 30/22/14/6 | Bit 29/21/13/5 | Bit 28/20/12/4 | Bit 27/19/11/3 | Bit 26/18/10/2 | Bit 25/17/9/1 | Bit 24/16/8/0 |
|-----------|-----------------|----------------|----------------|----------------|----------------|----------------|---------------|---------------|
| 31:24 | U-0 | U-0 | U-0 | U-0 | U-0 | U-0 | U-0 | U-0 |
| | — | — | — | — | — | — | — | — |
| 23:16 | U-0 | U-0 | U-0 | U-0 | U-0 | U-0 | U-0 | U-0 |
| | — | — | — | — | — | — | — | — |
| 15:8 | R/W-0 | R/W-0 | R/W-0 | R/W-0 | R/W-0 | R/W-0 | R/W-0 | R/W-0 |
| | FCSERRCNT<15:8> | | | | | | | |
| 7:0 | R/W-0 | R/W-0 | R/W-0 | R/W-0 | R/W-0 | R/W-0 | R/W-0 | R/W-0 |
| | FCSERRCNT<7:0> | | | | | | | |

Legend:

R = Readable bit W = Writable bit U = Unimplemented bit, read as '0'
 -n = Value at POR '1' = Bit is set '0' = Bit is cleared x = Bit is unknown

bit 31-16 **Unimplemented:** Read as '0'

bit 15-0 **FCSERRCNT<15:0>:** FCS Error Count bits

Increment count for frames received with FCS error and the frame length in bits is an integral multiple of 8 bits.

- Note 1:** This register is only used for RX operations.
- 2:** This register is automatically cleared by hardware after a read operation, unless the byte enables for bytes 0/1 are '0'.
- 3:** It is recommended to use the SET, CLR, or INV registers to set or clear any bit in this register. Setting or clearing any bits in this register should be only done for debug/test purposes.

PIC32MZ Embedded Connectivity with Floating Point Unit (EF) Family

REGISTER 30-22: ETHALGNERR: ETHERNET CONTROLLER ALIGNMENT ERRORS STATISTICS REGISTER

| Bit Range | Bit 31/23/15/7 | Bit 30/22/14/6 | Bit 29/21/13/5 | Bit 28/20/12/4 | Bit 27/19/11/3 | Bit 26/18/10/2 | Bit 25/17/9/1 | Bit 24/16/8/0 |
|-----------|------------------|----------------|----------------|----------------|----------------|----------------|---------------|---------------|
| 31:24 | U-0 | U-0 | U-0 | U-0 | U-0 | U-0 | U-0 | U-0 |
| | — | — | — | — | — | — | — | — |
| 23:16 | U-0 | U-0 | U-0 | U-0 | U-0 | U-0 | U-0 | U-0 |
| | — | — | — | — | — | — | — | — |
| 15:8 | R/W-0 | R/W-0 | R/W-0 | R/W-0 | R/W-0 | R/W-0 | R/W-0 | R/W-0 |
| | ALGNERRCNT<15:8> | | | | | | | |
| 7:0 | R/W-0 | R/W-0 | R/W-0 | R/W-0 | R/W-0 | R/W-0 | R/W-0 | R/W-0 |
| | ALGNERRCNT<7:0> | | | | | | | |

Legend:

R = Readable bit
-n = Value at POR

W = Writable bit
'1' = Bit is set

U = Unimplemented bit, read as '0'
'0' = Bit is cleared
x = Bit is unknown

bit 31-16 **Unimplemented:** Read as '0'

bit 15-0 **ALGNERRCNT<15:0>:** Alignment Error Count bits

Increment count for frames with alignment errors. Note that an alignment error is a frame that has an FCS error and the frame length in bits is not an integral multiple of 8 bits (a.k.a., dribble nibble)

Note 1: This register is only used for RX operations.

2: This register is automatically cleared by hardware after a read operation, unless the byte enables for bytes 0/1 are '0'.

3: It is recommended to use the SET, CLR, or INV registers to set or clear any bit in this register. Setting or clearing any bits in this register should be only done for debug/test purposes.

PIC32MZ Embedded Connectivity with Floating Point Unit (EF) Family

REGISTER 30-23: EMAC1CFG1: ETHERNET CONTROLLER MAC CONFIGURATION 1 REGISTER

| Bit Range | Bit 31/23/15/7 | Bit 30/22/14/6 | Bit 29/21/13/5 | Bit 28/20/12/4 | Bit 27/19/11/3 | Bit 26/18/10/2 | Bit 25/17/9/1 | Bit 24/16/8/0 |
|-----------|----------------|----------------|----------------|----------------|----------------|----------------|---------------|---------------|
| 31:24 | U-0 | U-0 | U-0 | U-0 | U-0 | U-0 | U-0 | U-0 |
| | — | — | — | — | — | — | — | — |
| 23:16 | U-0 | U-0 | U-0 | U-0 | U-0 | U-0 | U-0 | U-0 |
| | — | — | — | — | — | — | — | — |
| 15:8 | RW-1 | RW-0 | U-0 | U-0 | RW-0 | RW-0 | RW-0 | RW-0 |
| | SOFT RESET | SIM RESET | — | — | RESET RMCS | RESET RFUN | RESET TMCS | RESET TFUN |
| 7:0 | U-0 | U-0 | U-0 | RW-0 | RW-1 | RW-1 | RW-0 | RW-1 |
| | — | — | — | LOOPBACK | TX PAUSE | RX PAUSE | PASSALL | RX ENABLE |

Legend:

R = Readable bit W = Writable bit U = Unimplemented bit, read as '0'
-n = Value at POR '1' = Bit is set '0' = Bit is cleared x = Bit is unknown

bit 31-16 **Unimplemented:** Read as '0'

bit 15 **SOFTRESET:** Soft Reset bit

Setting this bit will put the MACMII in reset. Its default value is '1'.

bit 14 **SIMRESET:** Simulation Reset bit

Setting this bit will cause a reset to the random number generator within the Transmit Function.

bit 13-12 **Unimplemented:** Read as '0'

bit 11 **RESETRMCS:** Reset MCS/RX bit

Setting this bit will put the MAC Control Sub-layer/Receive domain logic in reset.

bit 10 **RESETRFUN:** Reset RX Function bit

Setting this bit will put the MAC Receive function logic in reset.

bit 9 **RESETMCS:** Reset MCS/TX bit

Setting this bit will put the MAC Control Sub-layer/TX domain logic in reset.

bit 8 **RESETTFUN:** Reset TX Function bit

Setting this bit will put the MAC Transmit function logic in reset.

bit 7-5 **Unimplemented:** Read as '0'

bit 4 **LOOPBACK:** MAC Loopback mode bit

1 = MAC Transmit interface is loop backed to the MAC Receive interface
0 = MAC normal operation

bit 3 **TXPAUSE:** MAC TX Flow Control bit

1 = PAUSE Flow Control frames are allowed to be transmitted
0 = PAUSE Flow Control frames are blocked

bit 2 **RXPAUSE:** MAC RX Flow Control bit

1 = The MAC acts upon received PAUSE Flow Control frames
0 = Received PAUSE Flow Control frames are ignored

bit 1 **PASSALL:** MAC Pass all Receive Frames bit

1 = The MAC will accept all frames regardless of type (Normal vs. Control)
0 = The received Control frames are ignored

bit 0 **RXENABLE:** MAC Receive Enable bit

1 = Enable the MAC receiving of frames
0 = Disable the MAC receiving of frames

Note: Both 16-bit and 32-bit accesses are allowed to these registers (including the SET, CLR and INV registers). 8-bit accesses are not allowed and are ignored by the hardware.

PIC32MZ Embedded Connectivity with Floating Point Unit (EF) Family

REGISTER 30-24: EMAC1CFG2: ETHERNET CONTROLLER MAC CONFIGURATION 2 REGISTER

| Bit Range | Bit 31/23/15/7 | Bit 30/22/14/6 | Bit 29/21/13/5 | Bit 28/20/12/4 | Bit 27/19/11/3 | Bit 26/18/10/2 | Bit 25/17/9/1 | Bit 25/16/8/0 |
|-----------|---------------------------|---------------------------|-----------------------------|----------------|----------------|----------------|---------------|---------------|
| 31:24 | U-0 | U-0 | U-0 | U-0 | U-0 | U-0 | U-0 | U-0 |
| | — | — | — | — | — | — | — | — |
| 23:16 | U-0 | U-0 | U-0 | U-0 | U-0 | U-0 | U-0 | U-0 |
| | — | — | — | — | — | — | — | — |
| 15:8 | U-0 | RW-1 | RW-0 | RW-0 | U-0 | U-0 | RW-0 | RW-0 |
| | — | EXCESS DFR | BPNOBK OFF | NOBK OFF | — | — | LONGPRE | PUREPRE |
| 7:0 | RW-1 | RW-0 | RW-1 | RW-1 | RW-0 | RW-0 | RW-1 | RW-0 |
| | AUTO PAD ^(1,2) | VLAN PAD ^(1,2) | PAD ENABLE ^(1,3) | CRC ENABLE | DELAYCRC | HUGEFRM | LENGTHCK | FULLDPLX |

Legend:

R = Readable bit

W = Writable bit

U = Unimplemented bit, read as '0'

-n = Value at POR

'1' = Bit is set

'0' = Bit is cleared

x = Bit is unknown

bit 31-15 **Unimplemented:** Read as '0'

bit 14 **EXCESSDER:** Excess Defer bit

1 = The MAC will defer to carrier indefinitely as per the Standard

0 = The MAC will abort when the excessive deferral limit is reached

bit 13 **BPNOBKOFF:** Backpressure/No Backoff bit

1 = The MAC after incidentally causing a collision during backpressure will immediately retransmit without backoff reducing the chance of further collisions and ensuring transmit packets get sent

0 = The MAC will not remove the backoff

bit 12 **NOBKOFF:** No Backoff bit

1 = Following a collision, the MAC will immediately retransmit rather than using the Binary Exponential Backoff algorithm as specified in the Standard

0 = Following a collision, the MAC will use the Binary Exponential Backoff algorithm

bit 11-10 **Unimplemented:** Read as '0'

bit 9 **LONGPRE:** Long Preamble Enforcement bit

1 = The MAC only allows receive packets which contain preamble fields less than 12 bytes in length

0 = The MAC allows any length preamble as per the Standard

bit 8 **PUREPRE:** Pure Preamble Enforcement bit

1 = The MAC will verify the content of the preamble to ensure it contains 0x55 and is error-free. A packet with errors in its preamble is discarded

0 = The MAC does not perform any preamble checking

bit 7 **AUTOPAD:** Automatic Detect Pad Enable bit^(1,2)

1 = The MAC will automatically detect the type of frame, either tagged or untagged, by comparing the two octets following the source address with 0x8100 (VLAN Protocol ID) and pad accordingly

0 = The MAC does not perform automatic detection

Note 1: Table 30-6 provides a description of the pad function based on the configuration of this register.

2: This bit is ignored if the PADENABLE bit is cleared.

3: This bit is used in conjunction with the AUTOPAD and VLANPAD bits.

Note: Both 16-bit and 32-bit accesses are allowed to these registers (including the SET, CLR and INV registers). 8-bit accesses are not allowed and are ignored by the hardware

PIC32MZ Embedded Connectivity with Floating Point Unit (EF) Family

REGISTER 30-24: EMAC1CFG2: ETHERNET CONTROLLER MAC CONFIGURATION 2 REGISTER

- bit 6 **VLANPAD:** VLAN Pad Enable bit^(1,2)
 1 = The MAC will pad all short frames to 64 bytes and append a valid CRC
 0 = The MAC does not perform padding of short frames
- bit 5 **PADENABLE:** Pad/CRC Enable bit^(1,3)
 1 = The MAC will pad all short frames
 0 = The frames presented to the MAC have a valid length
- bit 4 **CRCENABLE:** CRC Enable1 bit
 1 = The MAC will append a CRC to every frame whether padding was required or not. Must be set if the PADENABLE bit is set.
 0 = The frames presented to the MAC have a valid CRC
- bit 3 **DELAYCRC:** Delayed CRC bit
 This bit determines the number of bytes, if any, of proprietary header information that exist on the front of the IEEE 802.3 frames.
 1 = Four bytes of header (ignored by the CRC function)
 0 = No proprietary header
- bit 2 **HUGEFRM:** Huge Frame enable bit
 1 = Frames of any length are transmitted and received
 0 = Huge frames are not allowed for receive or transmit
- bit 1 **LENGTHCK:** Frame Length checking bit
 1 = Both transmit and receive frame lengths are compared to the Length/Type field. If the Length/Type field represents a length then the check is performed. Mismatches are reported on the transmit/receive statistics vector.
 0 = Length/Type field check is not performed
- bit 0 **FULLDPLX:** Full-Duplex Operation bit
 1 = The MAC operates in Full-Duplex mode
 0 = The MAC operates in Half-Duplex mode

- Note 1:** [Table 30-6](#) provides a description of the pad function based on the configuration of this register.
2: This bit is ignored if the PADENABLE bit is cleared.
3: This bit is used in conjunction with the AUTOPAD and VLANPAD bits.

Note: Both 16-bit and 32-bit accesses are allowed to these registers (including the SET, CLR and INV registers). 8-bit accesses are not allowed and are ignored by the hardware

TABLE 30-6: PAD OPERATION

| Type | AUTOPAD | VLANPAD | PADENABLE | Action |
|------|---------|---------|-----------|---|
| Any | x | x | 0 | No pad, check CRC |
| Any | 0 | 0 | 1 | Pad to 60 Bytes, append CRC |
| Any | x | 1 | 1 | Pad to 64 Bytes, append CRC |
| Any | 1 | 0 | 1 | If untagged: Pad to 60 Bytes, append CRC If VLAN tagged: Pad to 64 Bytes, append CRC |

PIC32MZ Embedded Connectivity with Floating Point Unit (EF) Family

REGISTER 30-25: EMAC1IPGT: ETHERNET CONTROLLER MAC BACK-TO-BACK INTERPACKET GAP REGISTER

| Bit Range | Bit 31/23/15/7 | Bit 30/22/14/6 | Bit 29/21/13/5 | Bit 28/20/12/4 | Bit 27/19/11/3 | Bit 26/18/10/2 | Bit 25/17/9/1 | Bit 24/16/8/0 |
|----------------|----------------|----------------|----------------|----------------|----------------|----------------|---------------|---------------|
| 31:24 | U-0 — | U-0 — | U-0 — | U-0 — | U-0 — | U-0 — | U-0 — | U-0 — |
| 23:16 | U-0 — | U-0 — | U-0 — | U-0 — | U-0 — | U-0 — | U-0 — | U-0 — |
| 15:8 | U-0 — | U-0 — | U-0 — | U-0 — | U-0 — | U-0 — | U-0 — | U-0 — |
| 7:0 | U-0 — | R/W-0 | R/W-0 | R/W-1 | R/W-0 | R/W-0 | R/W-1 | R/W-0 |
| B2BIPKTGP<6:0> | | | | | | | | |

Legend:

R = Readable bit
-n = Value at POR

W = Writable bit
'1' = Bit is set

U = Unimplemented bit, read as '0'
'0' = Bit is cleared
x = Bit is unknown

bit 31-7 **Unimplemented:** Read as '0'

bit 6-0 **B2BIPKTGP<6:0>:** Back-to-Back Interpacket Gap bits

This is a programmable field representing the nibble time offset of the minimum possible period between the end of any transmitted packet, to the beginning of the next. In Full-Duplex mode, the register value should be the desired period in nibble times minus 3. In Half-Duplex mode, the register value should be the desired period in nibble times minus 6. In Full-Duplex the recommended setting is 0x15 (21d), which represents the minimum IPG of 0.96 μ s (in 100 Mbps) or 9.6 μ s (in 10 Mbps). In Half-Duplex mode, the recommended setting is 0x12 (18d), which also represents the minimum IPG of 0.96 μ s (in 100 Mbps) or 9.6 μ s (in 10 Mbps).

Note: Both 16-bit and 32-bit accesses are allowed to these registers (including the SET, CLR and INV registers). 8-bit accesses are not allowed and are ignored by the hardware.

PIC32MZ Embedded Connectivity with Floating Point Unit (EF) Family

REGISTER 30-26: EMAC1IPGR: ETHERNET CONTROLLER MAC NON-BACK-TO-BACK INTERPACKET GAP REGISTER

| Bit Range | Bit 31/23/15/7 | Bit 30/22/14/6 | Bit 29/21/13/5 | Bit 28/20/12/4 | Bit 27/19/11/3 | Bit 26/18/10/2 | Bit 25/17/9/1 | Bit 24/16/8/0 |
|-----------|----------------|------------------|----------------|----------------|----------------|----------------|---------------|---------------|
| 31:24 | U-0 | U-0 | U-0 | U-0 | U-0 | U-0 | U-0 | U-0 |
| | — | — | — | — | — | — | — | — |
| 23:16 | U-0 | U-0 | U-0 | U-0 | U-0 | U-0 | U-0 | U-0 |
| | — | — | — | — | — | — | — | — |
| 15:8 | U-0 | R/W-0 | R/W-0 | R/W-0 | R/W-1 | R/W-1 | R/W-0 | R/W-0 |
| | — | NB2BIPKTGP1<6:0> | | | | | | |
| 7:0 | U-0 | R/W-0 | R/W-0 | R/W-1 | R/W-0 | R/W-0 | R/W-1 | R/W-0 |
| | — | NB2BIPKTGP2<6:0> | | | | | | |

Legend:

R = Readable bit W = Writable bit U = Unimplemented bit, read as '0'
-n = Value at POR '1' = Bit is set '0' = Bit is cleared x = Bit is unknown

bit 31-15 **Unimplemented:** Read as '0'

bit 14-8 **NB2BIPKTGP1<6:0>:** Non-Back-to-Back Interpacket Gap Part 1 bits

This is a programmable field representing the optional carrierSense window referenced in section 4.2.3.2.1 "Deference" of the IEEE 80.23 Specification. If carrier is detected during the timing of IPGR1, the MAC defers to carrier. If, however, carrier becomes after IPGR1, the MAC continues timing IPGR2 and transmits, knowingly causing a collision, thus ensuring fair access to medium. Its range of values is 0x0 to IPGR2. Its recommend value is 0xC (12d).

bit 7 **Unimplemented:** Read as '0'

bit 6-0 **NB2BIPKTGP2<6:0>:** Non-Back-to-Back Interpacket Gap Part 2 bits

This is a programmable field representing the non-back-to-back Inter-Packet-Gap. Its recommended value is 0x12 (18d), which represents the minimum IPG of 0.96 μ s (in 100 Mbps) or 9.6 μ s (in 10 Mbps).

Note: Both 16-bit and 32-bit accesses are allowed to these registers (including the SET, CLR and INV registers). 8-bit accesses are not allowed and are ignored by the hardware.

PIC32MZ Embedded Connectivity with Floating Point Unit (EF) Family

REGISTER 30-27: EMAC1CLR: ETHERNET CONTROLLER MAC COLLISION WINDOW/RETRY LIMIT REGISTER

| Bit Range | Bit 31/23/15/7 | Bit 30/22/14/6 | Bit 29/21/13/5 | Bit 28/20/12/4 | Bit 27/19/11/3 | Bit 26/18/10/2 | Bit 25/17/9/1 | Bit 24/16/8/0 |
|-----------|----------------|----------------|----------------|----------------|----------------|----------------|---------------|---------------|
| 31:24 | U-0 | U-0 | U-0 | U-0 | U-0 | U-0 | U-0 | U-0 |
| | — | — | — | — | — | — | — | — |
| 23:16 | U-0 | U-0 | U-0 | U-0 | U-0 | U-0 | U-0 | U-0 |
| | — | — | — | — | — | — | — | — |
| 15:8 | U-0 | U-0 | R/W-1 | R/W-1 | R/W-0 | R/W-1 | R/W-1 | R/W-1 |
| | — | — | CWINDOW<5:0> | | | | | |
| 7:0 | U-0 | U-0 | U-0 | U-0 | R/W-1 | R/W-1 | R/W-1 | R/W-1 |
| | — | — | — | — | RETX<3:0> | | | |

Legend:

R = Readable bit
-n = Value at POR

W = Writable bit
'1' = Bit is set

U = Unimplemented bit, read as '0'
'0' = Bit is cleared
x = Bit is unknown

bit 31-14 **Unimplemented:** Read as '0'

bit 13-8 **CWINDOW<5:0>:** Collision Window bits

This is a programmable field representing the slot time or collision window during which collisions occur in properly configured networks. Since the collision window starts at the beginning of transmission, the preamble and SFD is included. Its default of 0x37 (55d) corresponds to the count of frame bytes at the end of the window.

bit 7-4 **Unimplemented:** Read as '0'

bit 3-0 **RETX<3:0>:** Retransmission Maximum bits

This is a programmable field specifying the number of retransmission attempts following a collision before aborting the packet due to excessive collisions. The Standard specifies the maximum number of attempts (attemptLimit) to be 0xF (15d). Its default is '0xF'.

Note: Both 16-bit and 32-bit accesses are allowed to these registers (including the SET, CLR and INV registers). 8-bit accesses are not allowed and are ignored by the hardware.

PIC32MZ Embedded Connectivity with Floating Point Unit (EF) Family

REGISTER 30-28: EMAC1MAXF: ETHERNET CONTROLLER MAC MAXIMUM FRAME LENGTH REGISTER

| Bit Range | Bit 31/23/15/7 | Bit 30/22/14/6 | Bit 29/21/13/5 | Bit 28/20/12/4 | Bit 27/19/11/3 | Bit 26/18/10/2 | Bit 25/17/9/1 | Bit 24/16/8/0 |
|-----------|------------------------------|----------------|----------------|----------------|----------------|----------------|---------------|---------------|
| 31:24 | U-0 | U-0 | U-0 | U-0 | U-0 | U-0 | U-0 | U-0 |
| | — | — | — | — | — | — | — | — |
| 23:16 | U-0 | U-0 | U-0 | U-0 | U-0 | U-0 | U-0 | U-0 |
| | — | — | — | — | — | — | — | — |
| 15:8 | R/W-0 | R/W-0 | R/W-0 | R/W-0 | R/W-0 | R/W-1 | R/W-0 | R/W-1 |
| | MACMAXF<15:8> ⁽¹⁾ | | | | | | | |
| 7:0 | R/W-1 | R/W-1 | R/W-1 | R/W-0 | R/W-1 | R/W-1 | R/W-1 | R/W-0 |
| | MACMAXF<7:0> ⁽¹⁾ | | | | | | | |

Legend:

R = Readable bit W = Writable bit U = Unimplemented bit, read as '0'
 -n = Value at POR '1' = Bit is set '0' = Bit is cleared x = Bit is unknown

bit 31-16 **Unimplemented:** Read as '0'

bit 15-0 **MACMAXF<15:0>:** Maximum Frame Length bits⁽¹⁾

These bits reset to 0x05EE, which represents a maximum receive frame of 1518 octets. An untagged maximum size Ethernet frame is 1518 octets. A tagged frame adds four octets for a total of 1522 octets. If a shorter/longer maximum length restriction is desired, program this 16-bit field.

Note 1: If a proprietary header is allowed, this bit should be adjusted accordingly. For example, if 4-byte headers are prepended to frames, MACMAXF could be set to 1527 octets. This would allow the maximum VLAN tagged frame plus the 4-byte header.

Note: Both 16-bit and 32-bit accesses are allowed to these registers (including the SET, CLR and INV registers). 8-bit accesses are not allowed and are ignored by the hardware.

PIC32MZ Embedded Connectivity with Floating Point Unit (EF) Family

REGISTER 30-29: EMAC1SUPP: ETHERNET CONTROLLER MAC PHY SUPPORT REGISTER

| Bit Range | Bit 31/23/15/7 | Bit 30/22/14/6 | Bit 29/21/13/5 | Bit 28/20/12/4 | Bit 27/19/11/3 | Bit 26/18/10/2 | Bit 25/17/9/1 | Bit 24/16/8/0 |
|-----------|----------------|----------------|----------------|----------------|--------------------------|----------------|---------------|--------------------------|
| 31:24 | U-0 | U-0 | U-0 | U-0 | U-0 | U-0 | U-0 | U-0 |
| | — | — | — | — | — | — | — | — |
| 23:16 | U-0 | U-0 | U-0 | U-0 | U-0 | U-0 | U-0 | U-0 |
| | — | — | — | — | — | — | — | — |
| 15:8 | U-0 | U-0 | U-0 | U-0 | R/W-0 | U-0 | U-0 | R/W-0 |
| | — | — | — | — | RESETRMII ⁽¹⁾ | — | — | SPEEDRMII ⁽¹⁾ |
| 7:0 | U-0 | U-0 | U-0 | U-0 | U-0 | U-0 | U-0 | U-0 |
| | — | — | — | — | — | — | — | — |

Legend:

R = Readable bit

W = Writable bit

U = Unimplemented bit, read as '0'

-n = Value at POR

'1' = Bit is set

'0' = Bit is cleared

x = Bit is unknown

bit 31-12 **Unimplemented:** Read as '0'

bit 11 **RESETRMII:** Reset RMIILogic bit⁽¹⁾

1 = Reset the MAC RMIILogic module

0 = Normal operation.

bit 10-9 **Unimplemented:** Read as '0'

bit 8 **SPEEDRMII:** RMIILogic Speed bit⁽¹⁾

This bit configures the Reduced MII logic for the current operating speed.

1 = RMIILogic is running at 100 Mbps

0 = RMIILogic is running at 10 Mbps

bit 7-0 **Unimplemented:** Read as '0'

Note 1: This bit is only used for the RMIILogic module.

Note: Both 16-bit and 32-bit accesses are allowed to these registers (including the SET, CLR and INV registers). 8-bit accesses are not allowed and are ignored by the hardware.

PIC32MZ Embedded Connectivity with Floating Point Unit (EF) Family

REGISTER 30-30: EMAC1TEST: ETHERNET CONTROLLER MAC TEST REGISTER

| Bit Range | Bit 31/23/15/7 | Bit 30/22/14/6 | Bit 29/21/13/5 | Bit 28/20/12/4 | Bit 27/19/11/3 | Bit 26/18/10/2 | Bit 25/17/9/1 | Bit 24/16/8/0 |
|-----------|----------------|----------------|----------------|----------------|----------------|----------------|--------------------------|-------------------------|
| 31:24 | U-0 | U-0 | U-0 | U-0 | U-0 | U-0 | U-0 | U-0 |
| | — | — | — | — | — | — | — | — |
| 23:16 | U-0 | U-0 | U-0 | U-0 | U-0 | U-0 | U-0 | U-0 |
| | — | — | — | — | — | — | — | — |
| 15:8 | U-0 | U-0 | U-0 | U-0 | U-0 | U-0 | U-0 | U-0 |
| | — | — | — | — | — | — | — | — |
| 7:0 | U-0 | U-0 | U-0 | U-0 | U-0 | R/W-0 | R/W-0 | R/W-0 |
| | — | — | — | — | — | TESTBP | TESTPAUSE ⁽¹⁾ | SHRTQNTA ⁽¹⁾ |

Legend:

R = Readable bit W = Writable bit U = Unimplemented bit, read as '0'
 -n = Value at POR '1' = Bit is set '0' = Bit is cleared x = Bit is unknown

bit 31-3 **Unimplemented:** Read as '0'

bit 2 **TESTBP:** Test Backpressure bit

1 = The MAC will assert backpressure on the link. Backpressure causes preamble to be transmitted, raising carrier sense. A transmit packet from the system will be sent during backpressure.
 0 = Normal operation

bit 1 **TESTPAUSE:** Test PAUSE bit⁽¹⁾

1 = The MAC Control sub-layer will inhibit transmissions, just as if a PAUSE Receive Control frame with a non-zero pause time parameter was received
 0 = Normal operation

bit 0 **SHRTQNTA:** Shortcut PAUSE Quanta bit⁽¹⁾

1 = The MAC reduces the effective PAUSE Quanta from 64 byte-times to 1 byte-time
 0 = Normal operation

Note 1: This bit is only used for testing purposes.

Note: Both 16-bit and 32-bit accesses are allowed to these registers (including the SET, CLR and INV registers). 8-bit accesses are not allowed and are ignored by the hardware.

PIC32MZ Embedded Connectivity with Floating Point Unit (EF) Family

REGISTER 30-31: EMAC1MCFG: ETHERNET CONTROLLER MAC MII MANAGEMENT CONFIGURATION REGISTER

| Bit Range | Bit 31/23/15/7 | Bit 30/22/14/6 | Bit 29/21/13/5 | Bit 28/20/12/4 | Bit 27/19/11/3 | Bit 26/18/10/2 | Bit 25/17/9/1 | Bit 24/16/8/0 |
|-----------|----------------|----------------|----------------------------|----------------|----------------|----------------|---------------|---------------|
| 31:24 | U-0 | U-0 | U-0 | U-0 | U-0 | U-0 | U-0 | U-0 |
| | — | — | — | — | — | — | — | — |
| 23:16 | U-0 | U-0 | U-0 | U-0 | U-0 | U-0 | U-0 | U-0 |
| | — | — | — | — | — | — | — | — |
| 15:8 | R/W-0 | U-0 | U-0 | U-0 | U-0 | U-0 | U-0 | U-0 |
| | RESETMGMT | — | — | — | — | — | — | — |
| 7:0 | U-0 | U-0 | R/W-1 | R/W-0 | R/W-0 | R/W-0 | R/W-0 | R/W-0 |
| | — | — | CLKSEL<3:0> ⁽¹⁾ | | | | NOPRE | SCANINC |

Legend:

| | | |
|-------------------|------------------|--|
| R = Readable bit | W = Writable bit | U = Unimplemented bit, read as '0' |
| -n = Value at POR | '1' = Bit is set | '0' = Bit is cleared x = Bit is unknown |

bit 31-16 **Unimplemented:** Read as '0'

bit 15 **RESETMGMT:** Test Reset MII Management bit
 1 = Reset the MII Management module
 0 = Normal Operation

bit 14-6 **Unimplemented:** Read as '0'

bit 5-2 **CLKSEL<3:0>:** MII Management Clock Select 1 bits⁽¹⁾
 These bits are used by the clock divide logic in creating the MII Management Clock (MDC), which the IEEE 802.3 Specification defines to be no faster than 2.5 MHz. Some PHYs support clock rates up to 12.5 MHz.

bit 1 **NOPRE:** Suppress Preamble bit
 1 = The MII Management will perform read/write cycles without the 32-bit preamble field. Some PHYs support suppressed preamble
 0 = Normal read/write cycles are performed

bit 0 **SCANINC:** Scan Increment bit
 1 = The MII Management module will perform read cycles across a range of PHYs. The read cycles will start from address 1 through the value set in EMAC1MADR<PHYADDR>
 0 = Continuous reads of the same PHY

Note 1: Table 30-7 provides a description of the clock divider encoding.

Note: Both 16-bit and 32-bit accesses are allowed to these registers (including the SET, CLR and INV registers). 8-bit accesses are not allowed and are ignored by the hardware.

TABLE 30-7: MIIM CLOCK SELECTION

| MIIM Clock Select | EMAC1MCFG<5:2> |
|-----------------------|-----------------------|
| TPBCLK5 divided by 4 | 000x |
| TPBCLK5 divided by 6 | 0010 |
| TPBCLK5 divided by 8 | 0011 |
| TPBCLK5 divided by 10 | 0100 |
| TPBCLK5 divided by 14 | 0101 |
| TPBCLK5 divided by 20 | 0110 |
| TPBCLK5 divided by 28 | 0111 |
| TPBCLK5 divided by 40 | 1000 |
| TPBCLK5 divided by 48 | 1001 |
| TPBCLK5 divided by 50 | 1010 |
| Undefined | Any other combination |

PIC32MZ Embedded Connectivity with Floating Point Unit (EF) Family

REGISTER 30-32: EMAC1MCMD: ETHERNET CONTROLLER MAC MII MANAGEMENT COMMAND REGISTER

| Bit Range | Bit 31/23/15/7 | Bit 30/22/14/6 | Bit 29/21/13/5 | Bit 28/20/12/4 | Bit 27/19/11/3 | Bit 26/18/10/2 | Bit 25/17/9/1 | Bit 24/16/8/0 |
|-----------|----------------|----------------|----------------|----------------|----------------|----------------|---------------|---------------|
| 31:24 | U-0 | U-0 | U-0 | U-0 | U-0 | U-0 | U-0 | U-0 |
| | — | — | — | — | — | — | — | — |
| 23:16 | U-0 | U-0 | U-0 | U-0 | U-0 | U-0 | U-0 | U-0 |
| | — | — | — | — | — | — | — | — |
| 15:8 | U-0 | U-0 | U-0 | U-0 | U-0 | U-0 | U-0 | U-0 |
| | — | — | — | — | — | — | — | — |
| 7:0 | U-0 | U-0 | U-0 | U-0 | U-0 | U-0 | R/W-0 | R/W-0 |
| | — | — | — | — | — | — | SCAN | READ |

Legend:

R = Readable bit
-n = Value at POR

W = Writable bit
'1' = Bit is set

U = Unimplemented bit, read as '0'
'0' = Bit is cleared
x = Bit is unknown

bit 31-2 **Unimplemented:** Read as '0'

bit 1 **SCAN:** MII Management Scan Mode bit

- 1 = The MII Management module will perform read cycles continuously (for example, useful for monitoring the Link Fail)
- 0 = Normal Operation

bit 0 **READ:** MII Management Read Command bit

- 1 = The MII Management module will perform a single read cycle. The read data is returned in the EMAC1MRDD register
- 0 = The MII Management module will perform a write cycle. The write data is taken from the EMAC1MWTD register

Note: Both 16-bit and 32-bit accesses are allowed to these registers (including the SET, CLR and INV registers). 8-bit accesses are not allowed and are ignored by the hardware.

PIC32MZ Embedded Connectivity with Floating Point Unit (EF) Family

REGISTER 30-33: EMAC1MADR: ETHERNET CONTROLLER MAC MII MANAGEMENT ADDRESS REGISTER

| Bit Range | Bit 31/23/15/7 | Bit 30/22/14/6 | Bit 29/21/13/5 | Bit 28/20/12/4 | Bit 27/19/11/3 | Bit 26/18/10/2 | Bit 25/17/9/1 | Bit 24/16/8/0 |
|-----------|----------------|----------------|----------------|----------------|----------------|----------------|---------------|---------------|
| 31:24 | U-0 | U-0 | U-0 | U-0 | U-0 | U-0 | U-0 | U-0 |
| | — | — | — | — | — | — | — | — |
| 23:16 | U-0 | U-0 | U-0 | U-0 | U-0 | U-0 | U-0 | U-0 |
| | — | — | — | — | — | — | — | — |
| 15:8 | U-0 | U-0 | U-0 | R/W-0 | R/W-0 | R/W-0 | R/W-0 | R/W-1 |
| | — | — | — | PHYADDR<4:0> | | | | |
| 7:0 | U-0 | U-0 | U-0 | R/W-0 | R/W-0 | R/W-0 | R/W-0 | R/W-0 |
| | — | — | — | REGADDR<4:0> | | | | |

Legend:

R = Readable bit
-n = Value at POR

W = Writable bit
'1' = Bit is set

U = Unimplemented bit, read as '0'
'0' = Bit is cleared
x = Bit is unknown

bit 31-13 **Unimplemented:** Read as '0'

bit 12-8 **PHYADDR<4:0>:** MII Management PHY Address bits

This field represents the 5-bit PHY Address field of Management cycles. Up to 31 PHYs can be addressed (0 is reserved).

bit 7-5 **Unimplemented:** Read as '0'

bit 4-0 **REGADDR<4:0>:** MII Management Register Address bits

This field represents the 5-bit Register Address field of Management cycles. Up to 32 registers can be accessed.

Note: Both 16-bit and 32-bit accesses are allowed to these registers (including the SET, CLR and INV registers). 8-bit accesses are not allowed and are ignored by the hardware.

PIC32MZ Embedded Connectivity with Floating Point Unit (EF) Family

REGISTER 30-34: EMAC1MWTD: ETHERNET CONTROLLER MAC MII MANAGEMENT WRITE DATA REGISTER

| Bit Range | Bit 31/23/15/7 | Bit 30/22/14/6 | Bit 29/21/13/5 | Bit 28/20/12/4 | Bit 27/19/11/3 | Bit 26/18/10/2 | Bit 25/17/9/1 | Bit 24/16/8/0 |
|-----------|----------------|----------------|----------------|----------------|----------------|----------------|---------------|---------------|
| 31:24 | U-0 | U-0 | U-0 | U-0 | U-0 | U-0 | U-0 | U-0 |
| | — | — | — | — | — | — | — | — |
| 23:16 | U-0 | U-0 | U-0 | U-0 | U-0 | U-0 | U-0 | U-0 |
| | — | — | — | — | — | — | — | — |
| 15:8 | R/W-0 | R/W-0 | R/W-0 | R/W-0 | R/W-0 | R/W-0 | R/W-0 | R/W-0 |
| | MWTD<15:8> | | | | | | | |
| 7:0 | R/W-0 | R/W-0 | R/W-0 | R/W-0 | R/W-0 | R/W-0 | R/W-0 | R/W-0 |
| | MWTD<7:0> | | | | | | | |

Legend:

R = Readable bit W = Writable bit U = Unimplemented bit, read as '0'
 -n = Value at POR '1' = Bit is set '0' = Bit is cleared x = Bit is unknown

bit 31-16 **Unimplemented:** Read as '0'

bit 15-0 **MWTD<15:0>:** MII Management Write Data bits

When written, a MII Management write cycle is performed using the 16-bit data and the preconfigured PHY and Register addresses from the EMAC1MADR register.

Note: Both 16-bit and 32-bit accesses are allowed to these registers (including the SET, CLR and INV registers). 8-bit accesses are not allowed and are ignored by the hardware.

REGISTER 30-35: EMAC1MRDD: ETHERNET CONTROLLER MAC MII MANAGEMENT READ DATA REGISTER

| Bit Range | Bit 31/23/15/7 | Bit 30/22/14/6 | Bit 29/21/13/5 | Bit 28/20/12/4 | Bit 27/19/11/3 | Bit 26/18/10/2 | Bit 25/17/9/1 | Bit 24/16/8/0 |
|-----------|----------------|----------------|----------------|----------------|----------------|----------------|---------------|---------------|
| 31:24 | U-0 | U-0 | U-0 | U-0 | U-0 | U-0 | U-0 | U-0 |
| | — | — | — | — | — | — | — | — |
| 23:16 | U-0 | U-0 | U-0 | U-0 | U-0 | U-0 | U-0 | U-0 |
| | — | — | — | — | — | — | — | — |
| 15:8 | R/W-0 | R/W-0 | R/W-0 | R/W-0 | R/W-0 | R/W-0 | R/W-0 | R/W-0 |
| | MRDD<15:8> | | | | | | | |
| 7:0 | R/W-0 | R/W-0 | R/W-0 | R/W-0 | R/W-0 | R/W-0 | R/W-0 | R/W-0 |
| | MRDD<7:0> | | | | | | | |

Legend:

R = Readable bit W = Writable bit U = Unimplemented bit, read as '0'
 -n = Value at POR '1' = Bit is set '0' = Bit is cleared x = Bit is unknown

bit 31-16 **Unimplemented:** Read as '0'

bit 15-0 **MRDD<15:0>:** MII Management Read Data bits

Following a MII Management Read Cycle, the 16-bit data can be read from this location.

Note: Both 16-bit and 32-bit accesses are allowed to these registers (including the SET, CLR and INV registers). 8-bit accesses are not allowed and are ignored by the hardware.

PIC32MZ Embedded Connectivity with Floating Point Unit (EF) Family

REGISTER 30-36: EMAC1MIND: ETHERNET CONTROLLER MAC MII MANAGEMENT INDICATORS REGISTER

| Bit Range | Bit 31/23/15/7 | Bit 30/22/14/6 | Bit 29/21/13/5 | Bit 28/20/12/4 | Bit 27/19/11/3 | Bit 26/18/10/2 | Bit 25/17/9/1 | Bit 24/16/8/0 |
|-----------|----------------|----------------|----------------|----------------|----------------|----------------|---------------|---------------|
| 31:24 | U-0 | U-0 | U-0 | U-0 | U-0 | U-0 | U-0 | U-0 |
| | — | — | — | — | — | — | — | — |
| 23:16 | U-0 | U-0 | U-0 | U-0 | U-0 | U-0 | U-0 | U-0 |
| | — | — | — | — | — | — | — | — |
| 15:8 | U-0 | U-0 | U-0 | U-0 | U-0 | U-0 | U-0 | U-0 |
| | — | — | — | — | — | — | — | — |
| 7:0 | U-0 | U-0 | U-0 | U-0 | R/W-0 | R/W-0 | R/W-0 | R/W-0 |
| | — | — | — | — | LINKFAIL | NOTVALID | SCAN | MIIMBUSY |

Legend:

R = Readable bit

W = Writable bit

U = Unimplemented bit, read as '0'

-n = Value at POR

'1' = Bit is set

'0' = Bit is cleared

x = Bit is unknown

bit 31-4 **Unimplemented:** Read as '0'

bit 3 **LINKFAIL:** Link Fail bit

When '1' is returned - indicates link fail has occurred. This bit reflects the value last read from the PHY status register.

bit 2 **NOTVALID:** MII Management Read Data Not Valid bit

When '1' is returned - indicates an MII management read cycle has not completed and the Read Data is not yet valid.

bit 1 **SCAN:** MII Management Scanning bit

When '1' is returned - indicates a scan operation (continuous MII Management Read cycles) is in progress.

bit 0 **MIIMBUSY:** MII Management Busy bit

When '1' is returned - indicates MII Management module is currently performing an MII Management Read or Write cycle.

Note: Both 16-bit and 32-bit accesses are allowed to these registers (including the SET, CLR and INV registers). 8-bit accesses are not allowed and are ignored by the hardware.

PIC32MZ Embedded Connectivity with Floating Point Unit (EF) Family

REGISTER 30-37: EMAC1SA0: ETHERNET CONTROLLER MAC STATION ADDRESS 0 REGISTER

| Bit Range | Bit 31/23/15/7 | Bit 30/22/14/6 | Bit 29/21/13/5 | Bit 28/20/12/4 | Bit 27/19/11/3 | Bit 26/18/10/2 | Bit 25/17/9/1 | Bit 24/16/8/0 |
|-----------|----------------|----------------|----------------|----------------|----------------|----------------|---------------|---------------|
| 31:24 | U-0 | U-0 | U-0 | U-0 | U-0 | U-0 | U-0 | U-0 |
| | — | — | — | — | — | — | — | — |
| 23:16 | U-0 | U-0 | U-0 | U-0 | U-0 | U-0 | U-0 | U-0 |
| | — | — | — | — | — | — | — | — |
| 15:8 | R/W-P | R/W-P | R/W-P | R/W-P | R/W-P | R/W-P | R/W-P | R/W-P |
| | STNADDR6<7:0> | | | | | | | |
| 7:0 | R/W-P | R/W-P | R/W-P | R/W-P | R/W-P | R/W-P | R/W-P | R/W-P |
| | STNADDR5<7:0> | | | | | | | |

Legend:

R = Readable bit
-n = Value at POR

W = Writable bit
'1' = Bit is set

P = Programmable bit

U = Unimplemented bit, read as '0'

'0' = Bit is cleared x = Bit is unknown

bit 31-16 **Unimplemented:** Read as '0'

bit 15-8 **STNADDR6<7:0>:** Station Address Octet 6 bits

These bits hold the sixth transmitted octet of the station address.

bit 7-0 **STNADDR5<7:0>:** Station Address Octet 5 bits

These bits hold the fifth transmitted octet of the station address.

- Note 1:** Both 16-bit and 32-bit accesses are allowed to these registers (including the SET, CLR and INV registers). 8-bit accesses are not allowed and are ignored by the hardware.
- 2:** This register is loaded at reset from the factory preprogrammed station address.

PIC32MZ Embedded Connectivity with Floating Point Unit (EF) Family

REGISTER 30-38: EMAC1SA1: ETHERNET CONTROLLER MAC STATION ADDRESS 1 REGISTER

| Bit Range | Bit 31/23/15/7 | Bit 30/22/14/6 | Bit 29/21/13/5 | Bit 28/20/12/4 | Bit 27/19/11/3 | Bit 26/18/10/2 | Bit 25/17/9/1 | Bit 24/16/8/0 |
|-----------|----------------|----------------|----------------|----------------|----------------|----------------|---------------|---------------|
| 31:24 | U-0 | U-0 | U-0 | U-0 | U-0 | U-0 | U-0 | U-0 |
| | — | — | — | — | — | — | — | — |
| 23:16 | U-0 | U-0 | U-0 | U-0 | U-0 | U-0 | U-0 | U-0 |
| | — | — | — | — | — | — | — | — |
| 15:8 | R/W-P | R/W-P | R/W-P | R/W-P | R/W-P | R/W-P | R/W-P | R/W-P |
| | STNADDR4<7:0> | | | | | | | |
| 7:0 | R/W-P | R/W-P | R/W-P | R/W-P | R/W-P | R/W-P | R/W-P | R/W-P |
| | STNADDR3<7:0> | | | | | | | |

| | |
|-------------------|------------------------------------|
| Legend: | P = Programmable bit |
| R = Readable bit | W = Writable bit |
| -n = Value at POR | '1' = Bit is set |
| | '0' = Bit is cleared |
| | x = Bit is unknown |
| | U = Unimplemented bit, read as '0' |

bit 31-16 **Unimplemented:** Read as '0'

bit 15-8 **STNADDR4<7:0>:** Station Address Octet 4 bits
These bits hold the fourth transmitted octet of the station address.

bit 7-0 **STNADDR3<7:0>:** Station Address Octet 3 bits
These bits hold the third transmitted octet of the station address.

- | |
|--|
| <p>Note 1: Both 16-bit and 32-bit accesses are allowed to these registers (including the SET, CLR and INV registers). 8-bit accesses are not allowed and are ignored by the hardware.</p> <p>2: This register is loaded at reset from the factory preprogrammed station address.</p> |
|--|

PIC32MZ Embedded Connectivity with Floating Point Unit (EF) Family

REGISTER 30-39: EMAC1SA2: ETHERNET CONTROLLER MAC STATION ADDRESS 2 REGISTER

| Bit Range | Bit 31/23/15/7 | Bit 30/22/14/6 | Bit 29/21/13/5 | Bit 28/20/12/4 | Bit 27/19/11/3 | Bit 26/18/10/2 | Bit 25/17/9/1 | Bit 24/16/8/0 |
|-----------|----------------|----------------|----------------|----------------|----------------|----------------|---------------|---------------|
| 31:24 | U-0 | U-0 | U-0 | U-0 | U-0 | U-0 | U-0 | U-0 |
| | — | — | — | — | — | — | — | — |
| 23:16 | U-0 | U-0 | U-0 | U-0 | U-0 | U-0 | U-0 | U-0 |
| | — | — | — | — | — | — | — | — |
| 15:8 | R/W-P | R/W-P | R/W-P | R/W-P | R/W-P | R/W-P | R/W-P | R/W-P |
| | STNADDR2<7:0> | | | | | | | |
| 7:0 | R/W-P | R/W-P | R/W-P | R/W-P | R/W-P | R/W-P | R/W-P | R/W-P |
| | STNADDR1<7:0> | | | | | | | |

| | |
|-------------------|------------------------------------|
| Legend: | P = Programmable bit |
| R = Readable bit | W = Writable bit |
| -n = Value at POR | U = Unimplemented bit, read as '0' |
| | '1' = Bit is set |
| | '0' = Bit is cleared |
| | x = Bit is unknown |

bit 31-16 **Reserved:** Maintain as '0'; ignore read

bit 15-8 **STNADDR2<7:0>:** Station Address Octet 2 bits
These bits hold the second transmitted octet of the station address.

bit 7-0 **STNADDR1<7:0>:** Station Address Octet 1 bits
These bits hold the most significant (first transmitted) octet of the station address.

- Note 1:** Both 16-bit and 32-bit accesses are allowed to these registers (including the SET, CLR and INV registers). 8-bit accesses are not allowed and are ignored by the hardware.
- 2:** This register is loaded at reset from the factory preprogrammed station address.

31.0 COMPARATOR

Note: This data sheet summarizes the features of the PIC32MZ EF family of devices. It is not intended to be a comprehensive reference source. To complement the information in this data sheet, refer to **Section 19. “Comparator”** (DS60001110) in the *“PIC32 Family Reference Manual”*, which is available from the Microchip web site (www.microchip.com/PIC32).

The Analog Comparator module consists of two comparators that can be configured in a variety of ways.

Key features of the Analog Comparator module are:

- Differential inputs
- Rail-to-rail operation
- Selectable output polarity
- Selectable inputs:
 - Analog inputs multiplexed with I/O pins
 - On-chip internal absolute voltage reference
 - Comparator voltage reference (CVREF)
- Selectable interrupt generation

A block diagram of the comparator module is illustrated in [Figure 31-1](#).

Note: To avoid oscillation from the Comparators in Common mode, a low-pass filter is required on the inputs to the Comparator.

FIGURE 31-1: COMPARATOR BLOCK DIAGRAM

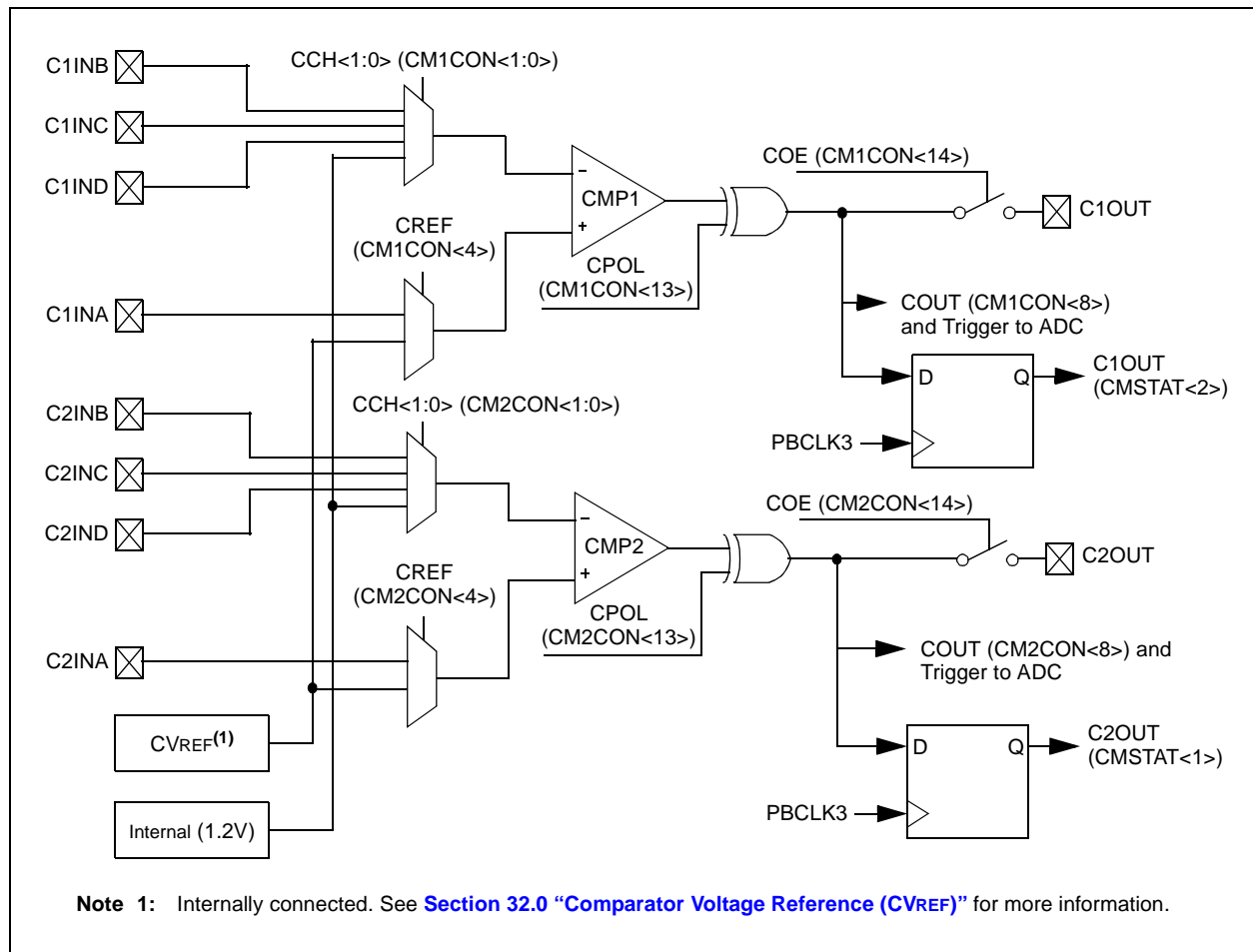

31.1 Comparator Control Registers

TABLE 31-1: COMPARATOR REGISTER MAP

| Virtual Address (BF84_#) | Register Name ⁽¹⁾ | Bit Range | Bits | | | | | | | | | | | | | | | All Resets |
|-----------------------------|---------------------------------|-----------|-------|-------|-------|-------|-------|-------|------|------|------------|------|------|------|------|------|----------|------------|
| | | | 31/15 | 30/14 | 29/13 | 28/12 | 27/11 | 26/10 | 25/9 | 24/8 | 23/7 | 22/6 | 21/5 | 20/4 | 19/3 | 18/2 | 17/1 | |
| C000 | CM1CON | 31:16 | — | — | — | — | — | — | — | — | — | — | — | — | — | — | — | 0000 |
| | | 15:0 | ON | COE | CPOL | — | — | — | — | COUT | EVPOL<1:0> | — | CREF | — | — | — | CCH<1:0> | 00C3 |
| C010 | CM2CON | 31:16 | — | — | — | — | — | — | — | — | — | — | — | — | — | — | — | 0000 |
| | | 15:0 | ON | COE | CPOL | — | — | — | — | COUT | EVPOL<1:0> | — | CREF | — | — | — | CCH<1:0> | 00C3 |
| C060 | CMSTAT | 31:16 | — | — | — | — | — | — | — | — | — | — | — | — | — | — | — | 0000 |
| | | 15:0 | — | — | — | — | — | — | — | — | — | — | — | — | — | — | C2OUT | C1OUT |

Legend: x = unknown value on Reset; — = unimplemented, read as '0'. Reset values are shown in hexadecimal.

Note 1: All registers in this table have corresponding CLR, SET and INV registers at their virtual addresses, plus offsets of 0x4, 0x8 and 0xC, respectively. See [Section 12.3 “CLR, SET, and INV Registers”](#) for more information.

PIC32MZ Embedded Connectivity with Floating Point Unit (EF) Family

REGISTER 31-1: CMxCON: COMPARATOR CONTROL REGISTER

| Bit Range | Bit 31/23/15/7 | Bit 30/22/14/6 | Bit 29/21/13/5 | Bit 28/20/12/4 | Bit 27/19/11/3 | Bit 26/18/10/2 | Bit 25/17/9/1 | Bit 24/16/8/0 |
|-----------|----------------|----------------|---------------------|----------------|----------------|----------------|---------------|---------------|
| 31:24 | U-0 | U-0 | U-0 | U-0 | U-0 | U-0 | U-0 | U-0 |
| | — | — | — | — | — | — | — | — |
| 23:16 | U-0 | U-0 | U-0 | U-0 | U-0 | U-0 | U-0 | U-0 |
| | — | — | — | — | — | — | — | — |
| 15:8 | R/W-0 | R/W-0 | R/W-0 | U-0 | U-0 | U-0 | U-0 | R-0 |
| | ON | COE | CPOL ⁽¹⁾ | — | — | — | — | COUT |
| 7:0 | R/W-1 | R/W-1 | U-0 | R/W-0 | U-0 | U-0 | R/W-1 | R/W-1 |
| | EVPOL<1:0> | | — | CREF | — | — | CCH<1:0> | |

Legend:

R = Readable bit W = Writable bit U = Unimplemented bit, read as '0'
 -n = Value at POR '1' = Bit is set '0' = Bit is cleared x = Bit is unknown

bit 31-16 **Unimplemented:** Read as '0'

bit 15 **ON:** Comparator ON bit

1 = Module is enabled. Setting this bit does not affect the other bits in this register

0 = Module is disabled and does not consume current. Clearing this bit does not affect the other bits in this register

bit 14 **COE:** Comparator Output Enable bit

1 = Comparator output is driven on the output CxOUT pin

0 = Comparator output is not driven on the output CxOUT pin

bit 13 **CPOL:** Comparator Output Inversion bit⁽¹⁾

1 = Output is inverted

0 = Output is not inverted

bit 12-9 **Unimplemented:** Read as '0'

bit 8 **COUT:** Comparator Output bit

1 = Output of the Comparator is a '1'

0 = Output of the Comparator is a '0'

bit 7-6 **EVPOL<1:0>:** Interrupt Event Polarity Select bits

11 = Comparator interrupt is generated on a low-to-high or high-to-low transition of the comparator output

10 = Comparator interrupt is generated on a high-to-low transition of the comparator output

01 = Comparator interrupt is generated on a low-to-high transition of the comparator output

00 = Comparator interrupt generation is disabled

bit 5 **Unimplemented:** Read as '0'

bit 4 **CREF:** Comparator Positive Input Configure bit

1 = Comparator non-inverting input is connected to the internal CVREF

0 = Comparator non-inverting input is connected to the CxINA pin

bit 3-2 **Unimplemented:** Read as '0'

bit 1-0 **CCH<1:0>:** Comparator Negative Input Select bits for Comparator

11 = Comparator inverting input is connected to the IVREF

10 = Comparator inverting input is connected to the CxIND pin

01 = Comparator inverting input is connected to the CxINC pin

00 = Comparator inverting input is connected to the CxINB pin

Note 1: Setting this bit will invert the signal to the comparator interrupt generator as well. This will result in an interrupt being generated on the opposite edge from the one selected by EVPOL<1:0>.

PIC32MZ Embedded Connectivity with Floating Point Unit (EF) Family

REGISTER 31-2: CMSTAT: COMPARATOR STATUS REGISTER

| Bit Range | Bit 31/23/15/7 | Bit 30/22/14/6 | Bit 29/21/13/5 | Bit 28/20/12/4 | Bit 27/19/11/3 | Bit 26/18/10/2 | Bit 25/17/9/1 | Bit 24/16/8/0 |
|-----------|----------------|----------------|----------------|----------------|----------------|----------------|---------------|---------------|
| 31:24 | U-0 | U-0 | U-0 | U-0 | U-0 | U-0 | U-0 | U-0 |
| | — | — | — | — | — | — | — | — |
| 23:16 | U-0 | U-0 | U-0 | U-0 | U-0 | U-0 | U-0 | U-0 |
| | — | — | — | — | — | — | — | — |
| 15:8 | U-0 | U-0 | U-0 | U-0 | U-0 | U-0 | U-0 | U-0 |
| | — | — | — | — | — | — | — | — |
| 7:0 | U-0 | U-0 | U-0 | U-0 | U-0 | U-0 | R-0 | R-0 |
| | — | — | — | — | — | — | C2OUT | C1OUT |

Legend:

R = Readable bit

W = Writable bit

U = Unimplemented bit, read as '0'

-n = Value at POR

'1' = Bit is set

'0' = Bit is cleared

x = Bit is unknown

bit 31-2 **Unimplemented:** Read as '0'

bit 1 **C2OUT:** Comparator Output bit

1 = Output of Comparator 2 is a '1'

0 = Output of Comparator 2 is a '0'

bit 0 **C1OUT:** Comparator Output bit

1 = Output of Comparator 1 is a '1'

0 = Output of Comparator 1 is a '0'

32.0 COMPARATOR VOLTAGE REFERENCE (CVREF)

Note: This data sheet summarizes the features of the PIC32MZ EF family of devices. It is not intended to be a comprehensive reference source. To complement the information in this data sheet, refer to **Section 20. “Comparator Voltage Reference (CVREF)”** (DS60001109) in the “PIC32 Family Reference Manual”, which is available from the Microchip web site (www.microchip.com/PIC32).

The CVREF module is a 16-tap, resistor ladder network that provides a selectable reference voltage. Although its primary purpose is to provide a reference for the analog comparators, it also may be used independently of them.

The resistor ladder is segmented to provide two ranges of voltage reference values and has a power-down function to conserve power when the reference is not being used. The module’s supply reference can be provided from either device VDD/VSS or an external voltage reference. The CVREF output is available for the comparators and typically available for pin output.

The comparator voltage reference has the following features:

- High and low range selection
- Sixteen output levels available for each range
- Internally connected to comparators to conserve device pins
- Output can be connected to a pin

A block diagram of the CVREF module is illustrated in [Figure 32-1](#).

FIGURE 32-1: COMPARATOR VOLTAGE REFERENCE BLOCK DIAGRAM

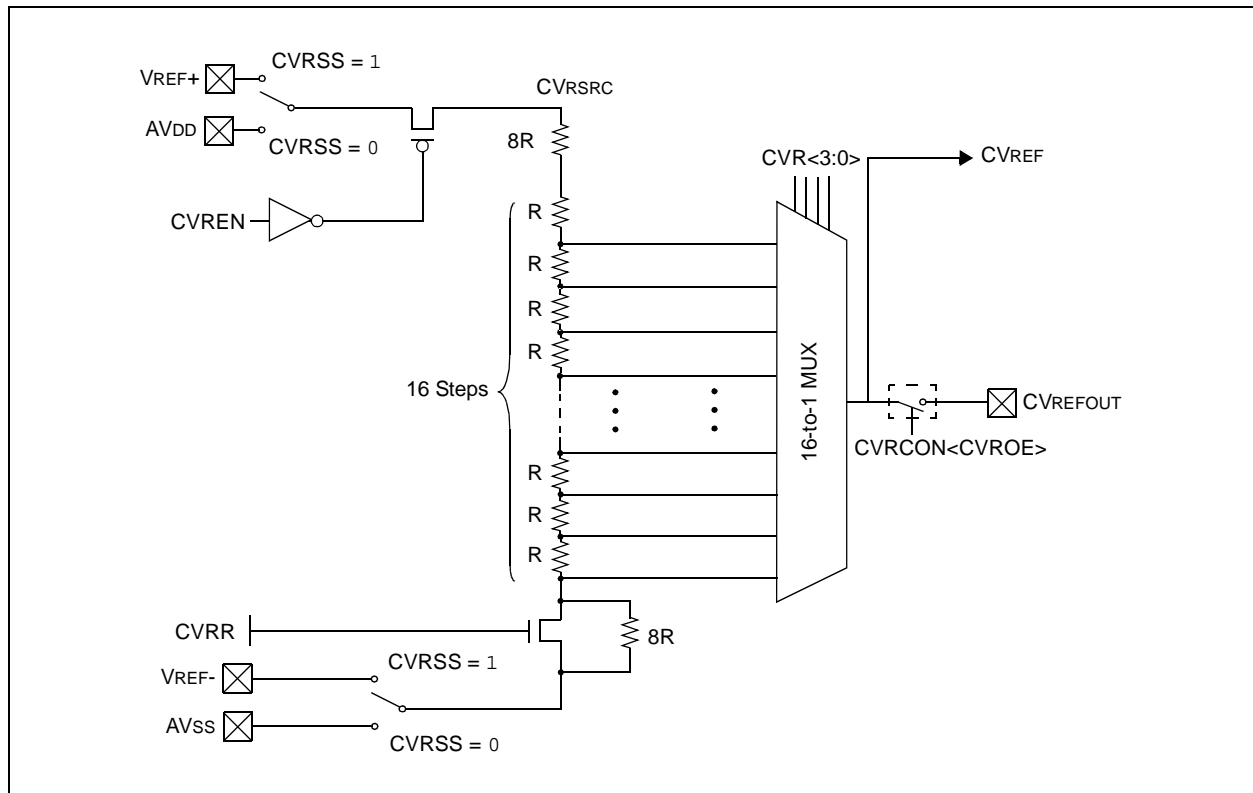

32.1 Comparator Voltage Reference Control Registers

TABLE 32-1: COMPARATOR VOLTAGE REFERENCE REGISTER MAP

| Virtual Address (BF80_#) | Register Name(s) | Bit Range | Bits | | | | | | | | | | | | | | | All Resets | |
|-----------------------------|---------------------|-----------|-------|-------|-------|-------|-------|-------|------|------|------|------|-------|------|-------|----------|------|------------|------|
| | | | 31/15 | 30/14 | 29/13 | 28/12 | 27/11 | 26/10 | 25/9 | 24/8 | 23/7 | 22/6 | 21/5 | 20/4 | 19/3 | 18/2 | 17/1 | | 16/0 |
| 0E00 | CVRCON | 31:16 | — | — | — | — | — | — | — | — | — | — | — | — | — | — | — | — | 0000 |
| | | 15:0 | ON | — | — | — | — | — | — | — | — | — | CVROE | CVRR | CVRSS | CVR<3:0> | | | 0000 |

Legend: x = unknown value on Reset; — = unimplemented, read as '0'. Reset values are shown in hexadecimal.

Note 1: The register in this table has corresponding CLR, SET and INV registers at their virtual addresses, plus offsets of 0x4, 0x8 and 0xC, respectively. See [Section 12.3 "CLR, SET, and INV Registers"](#) for more information.

PIC32MZ Embedded Connectivity with Floating Point Unit (EF) Family

NOTES:

33.0 POWER-SAVING FEATURES

Note: This data sheet summarizes the features of the PIC32MZ EF family of devices. It is not intended to be a comprehensive reference source. To complement the information in this data sheet, refer to **Section 10. “Power-Saving Features”** (DS60001130) in the *“PIC32 Family Reference Manual”*, which is available from the Microchip web site (www.microchip.com/PIC32).

This section describes power-saving features for the PIC32MZ EF devices. These devices offer various methods and modes that allow the user to balance power consumption with device performance. In all of the methods and modes described in this section, power-saving is controlled by software.

33.1 Power Saving with CPU Running

When the CPU is running, power consumption can be controlled by reducing the CPU clock frequency, lowering the speed of PBCLK7, or selecting a lower power clock source (i.e., LPRC or Sosc).

In addition, the Peripheral Bus Scaling mode is available for each peripheral bus where peripherals are clocked at reduced speed by selecting a higher divider for the associated PBCLKx, or by disabling the clock completely.

33.2 Power-Saving with CPU Halted

Peripherals and the CPU can be Halted or disabled to further reduce power consumption.

33.2.1 SLEEP MODE

Sleep mode has the lowest power consumption of the device power-saving operating modes. The CPU and most peripherals are Halted and the associated clocks are disabled. Select peripherals can continue to operate in Sleep mode and can be used to wake the device from Sleep. See the individual peripheral module sections for descriptions of behavior in Sleep.

Sleep mode includes the following characteristics:

- There can be a wake-up delay based on the oscillator selection
- The Fail-Safe Clock Monitor (FSCM) does not operate during Sleep mode
- The BOR circuit remains operative during Sleep mode
- The WDT, if enabled, is not automatically cleared prior to entering Sleep mode
- Some peripherals can continue to operate at limited functionality in Sleep mode. These peripherals include I/O pins that detect a change in the input signal, WDT, ADC, UART and peripherals that use an external clock input or the internal LPRC oscillator (e.g., RTCC, Timer1 and Input Capture).
- I/O pins continue to sink or source current in the same manner as they do when the device is not in Sleep

The processor will exit, or ‘wake-up’, from Sleep on one of the following events:

- On any interrupt from an enabled source that is operating in Sleep. The interrupt priority must be greater than the current CPU priority.
- On any form of device Reset
- On a WDT time-out

If the interrupt priority is lower than or equal to the current priority, the CPU will remain Halted, but the peripheral bus clocks will start running and the device will enter into Idle mode.

33.2.2 IDLE MODE

In Idle mode, the CPU is Halted; however, all clocks are still enabled. This allows peripherals to continue to operate. Peripherals can be individually configured to Halt when entering Idle by setting their respective SIDL bit. Latency, when exiting Idle mode, is very low due to the CPU oscillator source remaining active.

The device enters Idle mode when the SLPEN bit (OSCCON<4>) is clear and a WAIT instruction is executed.

The processor will wake or exit from Idle mode on the following events:

- On any interrupt event for which the interrupt source is enabled. The priority of the interrupt event must be greater than the current priority of the CPU. If the priority of the interrupt event is lower than or equal to current priority of the CPU, the CPU will remain Halted and the device will remain in Idle mode.
- On any form of device Reset
- On a WDT time-out interrupt

PIC32MZ Embedded Connectivity with Floating Point Unit (EF) Family

33.3 Peripheral Module Disable

The Peripheral Module Disable (PMD) registers provide a method to disable a peripheral module by stopping all clock sources supplied to that module. When a peripheral is disabled using the appropriate PMD control bit, the peripheral is in a minimum power consumption state. The control and status registers associated with the peripheral are also disabled, so writes to those registers do not have effect and read values are invalid.

To disable a peripheral, the associated PMDx bit must be set to '1'. To enable a peripheral, the associated PMDx bit must be cleared (default). See [Table 33-1](#) for more information.

Note: Disabling a peripheral module while its ON bit is set, may result in undefined behavior. The ON bit for the associated peripheral module must be cleared prior to disable a module via the PMDx bits.

TABLE 33-1: PERIPHERAL MODULE DISABLE BITS AND LOCATIONS⁽¹⁾

| Peripheral | PMDx bit Name | Register Name and Bit Location |
|------------------------------|---------------|--------------------------------|
| ADC | ADCMD | PMD1<0> |
| Comparator Voltage Reference | CVRMD | PMD1<12> |
| Comparator 1 | CMP1MD | PMD2<0> |
| Comparator 2 | CMP2MD | PMD2<1> |
| Input Capture 1 | IC1MD | PMD3<0> |
| Input Capture 2 | IC2MD | PMD3<1> |
| Input Capture 3 | IC3MD | PMD3<2> |
| Input Capture 4 | IC4MD | PMD3<3> |
| Input Capture 5 | IC5MD | PMD3<4> |
| Input Capture 6 | IC6MD | PMD3<5> |
| Input Capture 7 | IC7MD | PMD3<6> |
| Input Capture 8 | IC8MD | PMD3<7> |
| Input Capture 9 | IC9MD | PMD3<8> |
| Output Compare 1 | OC1MD | PMD3<16> |
| Output Compare 2 | OC2MD | PMD3<17> |
| Output Compare 3 | OC3MD | PMD3<18> |
| Output Compare 4 | OC4MD | PMD3<19> |
| Output Compare 5 | OC5MD | PMD3<20> |
| Output Compare 6 | OC6MD | PMD3<21> |
| Output Compare 7 | OC7MD | PMD3<22> |
| Output Compare 8 | OC8MD | PMD3<23> |
| Output Compare 9 | OC9MD | PMD3<24> |
| Timer1 | T1MD | PMD4<0> |
| Timer2 | T2MD | PMD4<1> |
| Timer3 | T3MD | PMD4<2> |
| Timer4 | T4MD | PMD4<3> |
| Timer5 | T5MD | PMD4<4> |
| Timer6 | T6MD | PMD4<5> |
| Timer7 | T7MD | PMD4<6> |
| Timer8 | T8MD | PMD4<7> |
| Timer9 | T9MD | PMD4<8> |
| UART1 | U1MD | PMD5<0> |
| UART2 | U2MD | PMD5<1> |

- Note 1:** Not all modules and associated PMDx bits are available on all devices. See [TABLE 1: "PIC32MZ EF Family Features"](#) for the lists of available peripherals.
- 2:** Module must not be busy after clearing the associated ON bit and prior to setting the USBMD bit.

PIC32MZ Embedded Connectivity with Floating Point Unit (EF) Family

TABLE 33-1: PERIPHERAL MODULE DISABLE BITS AND LOCATIONS⁽¹⁾ (CONTINUED)

| Peripheral | PMDx bit Name | Register Name and Bit Location |
|--------------------------|---------------|--------------------------------|
| UART3 | U3MD | PMD5<2> |
| UART4 | U4MD | PMD5<3> |
| UART5 | U5MD | PMD5<4> |
| UART6 | U6MD | PMD5<5> |
| SPI1 | SPI1MD | PMD5<8> |
| SPI2 | SPI2MD | PMD5<9> |
| SPI3 | SPI3MD | PMD5<10> |
| SPI4 | SPI4MD | PMD5<11> |
| SPI5 | SPI5MD | PMD5<12> |
| SPI6 | SPI6MD | PMD5<13> |
| I2C1 | I2C1MD | PMD5<16> |
| I2C2 | I2C2MD | PMD5<17> |
| I2C3 | I2C3MD | PMD5<18> |
| I2C4 | I2C4MD | PMD5<19> |
| I2C5 | I2C5MD | PMD5<20> |
| USB ⁽²⁾ | USBMD | PMD5<24> |
| CAN1 | CAN1MD | PMD5<28> |
| CAN2 | CAN2MD | PMD5<29> |
| RTCC | RTCCMD | PMD6<0> |
| Reference Clock Output 1 | REFO1MD | PMD6<8> |
| Reference Clock Output 2 | REFO2MD | PMD6<9> |
| Reference Clock Output 3 | REFO3MD | PMD6<10> |
| Reference Clock Output 4 | REFO4MD | PMD6<11> |
| PMP | PMPMD | PMD6<16> |
| EBI | EBIMD | PMD6<17> |
| SQI1 | SQI1MD | PMD6<23> |
| Ethernet | ETHMD | PMD6<28> |
| DMA | DMAMD | PMD7<4> |
| Random Number Generator | RNGMD | PMD7<20> |
| Crypto | CRYPTMD | PMD7<22> |

Note 1: Not all modules and associated PMDx bits are available on all devices. See [TABLE 1: “PIC32MZ EF Family Features”](#) for the lists of available peripherals.

2: Module must not be busy after clearing the associated ON bit and prior to setting the USBMD bit.

33.3.1 CONTROLLING CONFIGURATION CHANGES

Because peripherals can be disabled during run time, some restrictions on disabling peripherals are needed to prevent accidental configuration changes. PIC32MZ EF devices include two features to prevent alterations to enabled or disabled peripherals:

- Control register lock sequence
- Configuration bit select lock

33.3.1.1 Control Register Lock

Under normal operation, writes to the PMDx registers are not allowed. Attempted writes appear to execute normally, but the contents of the registers remain unchanged. To change these registers, they must be unlocked in hardware. The register lock is controlled by the PMDLOCK Configuration bit (CFGCON<12>). Setting PMDLOCK prevents writes to the control registers; clearing PMDLOCK allows writes.

To set or clear PMDLOCK, an unlock sequence must be executed. Refer to **Section 42. “Oscillators with Enhanced PLL”** in the *“PIC32 Family Reference Manual”* for details.

33.3.1.2 Configuration Bit Select Lock

As an additional level of safety, the device can be configured to prevent more than one write session to the PMDx registers. The PMDL1WAY Configuration bit (DEVCFG3<28>) blocks the PMDLOCK bit from being cleared after it has been set once. If PMDLOCK remains set, the register unlock procedure does not execute, and the PPS control registers cannot be written to. The only way to clear the bit and re-enable PMD functionality is to perform a device Reset.

TABLE 33-2: PERIPHERAL MODULE DISABLE REGISTER SUMMARY

| Virtual Address (BF80_#) | Register Name ⁽¹⁾ | Bit Range | Bits | | | | | | | | | | | | | | | All Resets | |
|-----------------------------|---------------------------------|-----------|-------|-------|--------|--------|---------|---------|---------|---------|--------|-------|---------|--------|--------|--------|--------|------------|--------|
| | | | 31/15 | 30/14 | 29/13 | 28/12 | 27/11 | 26/10 | 25/9 | 24/8 | 23/7 | 22/6 | 21/5 | 20/4 | 19/3 | 18/2 | 17/1 | | 16/0 |
| 0040 | PMD1 | 31:16 | — | — | — | — | — | — | — | — | — | — | — | — | — | — | — | — | 0000 |
| | | 15:0 | — | — | — | CVRMD | — | — | — | — | — | — | — | — | — | — | — | — | — |
| 0050 | PMD2 | 31:16 | — | — | — | — | — | — | — | — | — | — | — | — | — | — | — | — | 0000 |
| | | 15:0 | — | — | — | — | — | — | — | — | — | — | — | — | — | — | — | CMP2MD | CMP1MD |
| 0060 | PMD3 | 31:16 | — | — | — | — | — | — | — | OC9MD | OC8MD | OC7MD | OC6MD | OC5MD | OC4MD | OC3MD | OC2MD | OC1MD | 0000 |
| | | 15:0 | — | — | — | — | — | — | — | IC9MD | IC8MD | IC7MD | IC6MD | IC5MD | IC4MD | IC3MD | IC2MD | IC1MD | 0000 |
| 0070 | PMD4 | 31:16 | — | — | — | — | — | — | — | — | — | — | — | — | — | — | — | — | 0000 |
| | | 15:0 | — | — | — | — | — | — | — | T9MD | T8MD | T7MD | T6MD | T5MD | T4MD | T3MD | T2MD | T1MD | 0000 |
| 0080 | PMD5 | 31:16 | — | — | CAN2MD | CAN1MD | — | — | — | USBMD | — | — | — | I2C5MD | I2C4MD | I2C3MD | I2C2MD | I2C1MD | 0000 |
| | | 15:0 | — | — | SPI6MD | SPI5MD | SPI4MD | SPI3MD | SPI2MD | SPI1MD | — | — | U6MD | U5MD | U4MD | U3MD | U2MD | U1MD | 0000 |
| 0090 | PMD6 | 31:16 | — | — | — | ETHMD | — | — | — | — | SQI1MD | — | — | — | — | — | EBIMD | PMPMD | 0000 |
| | | 15:0 | — | — | — | — | REFO4MD | REFO3MD | REFO2MD | REFO1MD | — | — | — | — | — | — | — | — | RTCCMD |
| 00A0 | PMD7 | 31:16 | — | — | — | — | — | — | — | — | — | — | CRYPTMD | — | RNGMD | — | — | — | 0000 |
| | | 15:0 | — | — | — | — | — | — | — | — | — | — | — | DMAMD | — | — | — | — | 0000 |

Legend: x = unknown value on Reset; — = unimplemented, read as '0'. Reset values are shown in hexadecimal.

Note 1: All registers have corresponding CLR, SET and INV registers at their virtual addresses, plus offsets of 0x4, 0x8 and 0xC, respectively. See [Section 12.3 “CLR, SET, and INV Registers”](#) for more information.

PIC32MZ Embedded Connectivity with Floating Point Unit (EF) Family

NOTES:

34.0 SPECIAL FEATURES

Note: This data sheet summarizes the features of the PIC32MZ EF family of devices. However, it is not intended to be a comprehensive reference source. To complement the information in this data sheet, refer to **Section 32. “Configuration”** (DS60001124) and **Section 33. “Programming and Diagnostics”** (DS60001129) in the *“PIC32 Family Reference Manual”*, which are available from the Microchip web site (www.microchip.com/PIC32).

PIC32MZ EF devices include several features intended to maximize application flexibility and reliability and minimize cost through elimination of external components. These are:

- Flexible device configuration
- Joint Test Action Group (JTAG) interface
- In-Circuit Serial Programming™ (ICSP™)
- Internal temperature sensor

34.1 Configuration Bits

PIC32MZ EF devices contain two Boot Flash memories (Boot Flash 1 and Boot Flash 2), each with an associated configuration space. These configuration spaces can be programmed to contain various device configurations. Configuration space that is aliased by the Lower Boot Alias memory region is used to provide values for Configuration registers listed below. See **4.1.1 “Boot Flash Sequence and Configuration Spaces”** for more information.

- [DEVSIGN0/ADEVSIGN0: Device Signature Word 0 Register](#)
- [DEVCP0/ADEVCP0: Device Code-Protect 0 Register](#)
- [DEVCFG0/ADEVCFG0: Device Configuration Word 0](#)
- [DEVCFG1/ADEVCFG1: Device Configuration Word 1](#)
- [DEVCFG2/ADEVCFG2: Device Configuration Word 2](#)
- [DEVCFG3/ADEVCFG3: Device Configuration Word 3](#)

The following run-time programmable Configuration registers provide additional configuration control:

- [CFGCON: Configuration Control Register](#)
- [CFGEBIA: External Bus Interface Address Pin Configuration Register](#)
- [CFGEBIC: External Bus Interface Control Pin Configuration Register](#)
- [CFGPG: Permission Group Configuration Register](#)

In addition, the DEVID register (see [Register 34-11](#)) provides device and revision information, and the DEVSNO and DEVSNI registers contain a unique serial number of the device (see [Register 34-12](#)).

Note: Do not use word program operation (NVMOP<3:0> = 0001) when programming the device words that are described in this section.

34.2 Registers

TABLE 34-1: DEVCFG: DEVICE CONFIGURATION WORD SUMMARY

| Virtual Address (BFC0_#) | Register Name | Bit Range | Bits | | | | | | | | | | | | | | | | All Resets | |
|-----------------------------|---------------|-----------|---------------|-------------|---------|----------|---------|----------------|--------------|--------------|---------|---------------|---------------|-------|-------------|---------------|--------|---------------|------------|------|
| | | | 31/15 | 30/14 | 29/13 | 28/12 | 27/11 | 26/10 | 25/9 | 24/8 | 23/7 | 22/6 | 21/5 | 20/4 | 19/3 | 18/2 | 17/1 | 16/0 | | |
| FFC0 | DEVCFG3 | 31:16 | — | FUSBIDIO | IOL1WAY | PMDL1WAY | PGL1WAY | — | FETHIO | FMIEN | — | — | — | — | — | — | — | xxxx | | |
| | | 15:0 | USERID<15:0> | | | | | | | | | | | | | | | | xxxx | |
| FFC4 | DEVCFG2 | 31:16 | — | UPLLFSEL | — | — | — | — | — | — | — | — | — | — | — | — | — | FPLLODIV<2:0> | xxxx | |
| | | 15:0 | FPLLMULT<6:0> | | | | | | | | FPLLCLK | FPLL RNG<2:0> | | | | FPLLIDIV<2:0> | | | | xxxx |
| FFC8 | DEVCFG1 | 31:16 | FDMTEN | DMTCNT<4:0> | | | | FWDTWINSZ<1:0> | | FWDTEN | WINDIS | WDTSPGM | WDTPS<4:0> | | | | xxxx | | | |
| | | 15:0 | FCKSM<1:0> | | — | — | — | OSCI0FNC | POSCMOD<1:0> | | IESO | FSOSCEN | DMTINTV<2:0> | | FNOSC<2:0> | | | xxxx | | |
| FFCC | DEVCFG0 | 31:16 | — | EJTAGBEN | — | — | — | — | — | — | — | POSCBOOST | POSCGAIN<1:0> | | SOSCB00ST | SOSCGAIN<1:0> | | xxxx | | |
| | | 15:0 | SMCLR | DBGPER<2:0> | | | | — | FSLEEP | FECCCON<1:0> | | — | BOOTISA | TRCEN | ICESEL<1:0> | | JTAGEN | DEBUG<1:0> | | xxxx |
| FFD0 | DEVCP3 | 31:16 | — | — | — | — | — | — | — | — | — | — | — | — | — | — | — | — | xxxx | |
| | | 15:0 | — | — | — | — | — | — | — | — | — | — | — | — | — | — | — | — | — | xxxx |
| FFD4 | DEVCP2 | 31:16 | — | — | — | — | — | — | — | — | — | — | — | — | — | — | — | — | — | xxxx |
| | | 15:0 | — | — | — | — | — | — | — | — | — | — | — | — | — | — | — | — | — | — |
| FFD8 | DEVCP1 | 31:16 | — | — | — | — | — | — | — | — | — | — | — | — | — | — | — | — | — | xxxx |
| | | 15:0 | — | — | — | — | — | — | — | — | — | — | — | — | — | — | — | — | — | — |
| FFDC | DEVCP0 | 31:16 | — | — | — | CP | — | — | — | — | — | — | — | — | — | — | — | — | — | xxxx |
| | | 15:0 | — | — | — | — | — | — | — | — | — | — | — | — | — | — | — | — | — | — |
| FFE0 | DEVSIGN3 | 31:16 | — | — | — | — | — | — | — | — | — | — | — | — | — | — | — | — | — | xxxx |
| | | 15:0 | — | — | — | — | — | — | — | — | — | — | — | — | — | — | — | — | — | — |
| FFE4 | DEVSIGN2 | 31:16 | — | — | — | — | — | — | — | — | — | — | — | — | — | — | — | — | — | xxxx |
| | | 15:0 | — | — | — | — | — | — | — | — | — | — | — | — | — | — | — | — | — | — |
| FFE8 | DEVSIGN1 | 31:16 | — | — | — | — | — | — | — | — | — | — | — | — | — | — | — | — | — | xxxx |
| | | 15:0 | — | — | — | — | — | — | — | — | — | — | — | — | — | — | — | — | — | — |
| FFEC | DEVSIGN0 | 31:16 | 0 | — | — | — | — | — | — | — | — | — | — | — | — | — | — | — | — | xxxx |
| | | 15:0 | — | — | — | — | — | — | — | — | — | — | — | — | — | — | — | — | — | — |

Legend: x = unknown value on Reset; — = Reserved, read as '1'. Reset values are shown in hexadecimal.

TABLE 34-2: ADEVCFG: ALTERNATE DEVICE CONFIGURATION WORD SUMMARY

| Virtual Address (BFC0_#) | Register Name | Bit Range | Bits | | | | | | | | | | | | | | | | All Resets | |
|--------------------------|---------------|-----------|---------------|-------------|---------|----------|---------|----------------|----------|--------------|--------|---------|--------------|---------------|-------------|------|--------|---------------|------------|------|
| | | | 31/15 | 30/14 | 29/13 | 28/12 | 27/11 | 26/10 | 25/9 | 24/8 | 23/7 | 22/6 | 21/5 | 20/4 | 19/3 | 18/2 | 17/1 | 16/0 | | |
| FF40 | ADEVCFG3 | 31:16 | — | FUSBIDIO | IOL1WAY | PMDL1WAY | PGL1WAY | — | FETHIO | FMIEN | — | — | — | — | — | — | — | — | xxxx | |
| | | 15:0 | USERID<15:0> | | | | | | | | | | | | | | | | xxxx | |
| FF44 | ADEVCFG2 | 31:16 | — | UPLLFSEL | — | — | — | — | — | — | — | — | — | — | — | — | — | FPLLIDIV<2:0> | xxxx | |
| | | 15:0 | FPLLMULT<6:0> | | | | | | FPLLICK | FPLLRNG<2:0> | | | | FPLLIDIV<2:0> | | | | xxxx | | |
| FF48 | ADEVCFG1 | 31:16 | FDMTEN | DMTCNT<4:0> | | | | FWDTWINSZ<1:0> | | FWDTEN | WINDIS | WDTSPGM | WDTPS<4:0> | | | | xxxx | | | |
| | | 15:0 | FCKSM<1:0> | | — | — | — | — | OSCIOfNC | POSCMOD<1:0> | IESO | FSOSCEN | DMTINTV<2:0> | | FNOSC<2:0> | | xxxx | | | |
| FF4C | ADEVCFG0 | 31:16 | — | EJTAGBEN | — | — | — | — | — | — | — | — | — | — | — | — | — | — | — | xxxx |
| | | 15:0 | SMCLR | DBGPER<2:0> | | | | — | FSLEEP | FECCCON<1:0> | | — | BOOTISA | TRCEN | ICESEL<1:0> | | JTAGEN | DEBUG<1:0> | | xxxx |
| FF50 | ADEVCP3 | 31:16 | — | — | — | — | — | — | — | — | — | — | — | — | — | — | — | — | — | xxxx |
| | | 15:0 | — | — | — | — | — | — | — | — | — | — | — | — | — | — | — | — | — | — |
| FF54 | ADEVCP2 | 31:16 | — | — | — | — | — | — | — | — | — | — | — | — | — | — | — | — | — | xxxx |
| | | 15:0 | — | — | — | — | — | — | — | — | — | — | — | — | — | — | — | — | — | — |
| FF58 | ADEVCP1 | 31:16 | — | — | — | — | — | — | — | — | — | — | — | — | — | — | — | — | — | xxxx |
| | | 15:0 | — | — | — | — | — | — | — | — | — | — | — | — | — | — | — | — | — | — |
| FF5C | ADEVCP0 | 31:16 | — | — | — | CP | — | — | — | — | — | — | — | — | — | — | — | — | — | xxxx |
| | | 15:0 | — | — | — | — | — | — | — | — | — | — | — | — | — | — | — | — | — | — |
| FF60 | ADEVSIGN3 | 31:16 | — | — | — | — | — | — | — | — | — | — | — | — | — | — | — | — | — | xxxx |
| | | 15:0 | — | — | — | — | — | — | — | — | — | — | — | — | — | — | — | — | — | — |
| FF64 | ADEVSIGN2 | 31:16 | — | — | — | — | — | — | — | — | — | — | — | — | — | — | — | — | — | xxxx |
| | | 15:0 | — | — | — | — | — | — | — | — | — | — | — | — | — | — | — | — | — | — |
| FF68 | ADEVSIGN1 | 31:16 | — | — | — | — | — | — | — | — | — | — | — | — | — | — | — | — | — | xxxx |
| | | 15:0 | — | — | — | — | — | — | — | — | — | — | — | — | — | — | — | — | — | — |
| FF6C | ADEVSIGN0 | 31:16 | 0 | — | — | — | — | — | — | — | — | — | — | — | — | — | — | — | — | xxxx |
| | | 15:0 | — | — | — | — | — | — | — | — | — | — | — | — | — | — | — | — | — | — |

Legend: x = unknown value on Reset; — = Reserved, read as '1'. Reset values are shown in hexadecimal.

PIC32MZ Embedded Connectivity with Floating Point Unit (EF) Family

REGISTER 34-1: DEVSIGN0/ADEVSIGN0: DEVICE SIGNATURE WORD 0 REGISTER

| Bit Range | Bit 31/23/15/7 | Bit 30/22/14/6 | Bit 29/21/13/5 | Bit 28/20/12/4 | Bit 27/19/11/3 | Bit 26/18/10/2 | Bit 25/17/9/1 | Bit 24/16/8/0 |
|-----------|----------------|----------------|----------------|----------------|----------------|----------------|---------------|---------------|
| 31:24 | r-0 | r-1 | r-1 | r-1 | r-1 | r-1 | r-1 | r-1 |
| | — | — | — | — | — | — | — | — |
| 23:16 | r-1 | r-1 | r-1 | r-1 | r-1 | r-1 | r-1 | r-1 |
| | — | — | — | — | — | — | — | — |
| 15:8 | r-1 | r-1 | r-1 | r-1 | r-1 | r-1 | r-1 | r-1 |
| | — | — | — | — | — | — | — | — |
| 7:0 | r-1 | r-1 | r-1 | r-1 | r-1 | r-1 | r-1 | r-1 |
| | — | — | — | — | — | — | — | — |

| | | |
|-------------------|------------------|------------------------------------|
| Legend: | r = Reserved bit | U = Unimplemented bit, read as '0' |
| R = Readable bit | W = Writable bit | '0' = Bit is cleared |
| -n = Value at POR | '1' = Bit is set | x = Bit is unknown |

bit 31 **Reserved:** Write as '0'

bit 30-0 **Reserved:** Write as '1'

Note: The DEVSIGN1 through DEVSIGN3 and ADEVSIGN1 through ADEVSIGN3 registers are used for Quad Word programming operation when programming the DEVSIGN0/ADEVSIGN0 registers, and do not contain any valid information.

REGISTER 34-2: DEVCP0/ADEVCP0: DEVICE CODE-PROTECT 0 REGISTER

| Bit Range | Bit 31/23/15/7 | Bit 30/22/14/6 | Bit 29/21/13/5 | Bit 28/20/12/4 | Bit 27/19/11/3 | Bit 26/18/10/2 | Bit 25/17/9/1 | Bit 24/16/8/0 |
|-----------|----------------|----------------|----------------|----------------|----------------|----------------|---------------|---------------|
| 31:24 | r-1 | r-1 | r-1 | R/P | r-1 | r-1 | r-1 | r-1 |
| | — | — | — | CP | — | — | — | — |
| 23:16 | r-1 | r-1 | r-1 | r-1 | r-1 | r-1 | r-1 | r-1 |
| | — | — | — | — | — | — | — | — |
| 15:8 | r-1 | r-1 | r-1 | r-1 | r-1 | r-1 | r-1 | r-1 |
| | — | — | — | — | — | — | — | — |
| 7:0 | r-1 | r-1 | r-1 | r-1 | r-1 | r-1 | r-1 | r-1 |
| | — | — | — | — | — | — | — | — |

| | | |
|-------------------|------------------|------------------------------------|
| Legend: | r = Reserved bit | P = Programmable bit |
| R = Readable bit | W = Writable bit | U = Unimplemented bit, read as '0' |
| -n = Value at POR | '1' = Bit is set | '0' = Bit is cleared |
| | | x = Bit is unknown |

bit 31-29 **Reserved:** Write as '1'

bit 28 **CP:** Code-Protect bit

Prevents boot and program Flash memory from being read or modified by an external programming device.

1 = Protection is disabled

0 = Protection is enabled

bit 27-0 **Reserved:** Write as '1'

Note: The DEVCP1 through DEVCP3 and ADEVCP1 through ADEVCP3 registers are used for Quad Word programming operation when programming the DEVCP0/ADEVCP0 registers, and do not contain any valid information.

PIC32MZ Embedded Connectivity with Floating Point Unit (EF) Family

REGISTER 34-3: DEVCFG0/ADEVCFG0: DEVICE CONFIGURATION WORD 0

| Bit Range | Bit 31/23/15/7 | Bit 30/22/14/6 | Bit 29/21/13/5 | Bit 28/20/12/4 | Bit 27/19/11/3 | Bit 26/18/10/2 | Bit 25/17/9/1 | Bit 24/16/8/0 |
|-----------|----------------|----------------|----------------|----------------|-----------------------|----------------|---------------|---------------|
| 31:24 | r-x | R/P | r-1 | r-1 | r-1 | r-1 | r-1 | r-1 |
| | — | EJTAGBEN | — | — | — | — | — | — |
| 23:16 | r-1 | r-1 | R/P | R/P | R/P | R/P | R/P | R/P |
| | — | — | POSCBOOST | POSCGAIN<1:0> | SOSCBOOST | SOSCGAIN<1:0> | — | — |
| 15:8 | R/P | R/P | R/P | R/P | r-y | R/P | R/P | R/P |
| | SMCLR | DBGPER<2:0> | | | — | FSLEEP | FECCCON<1:0> | |
| 7:0 | r-1 | R/P | R/P | R/P | R/P | R/P | R/P | R/P |
| | — | BOOTISA | TRCEN | ICESEL<1:0> | JTAGEN ⁽¹⁾ | DEBUG<1:0> | | |

| | | |
|-------------------|----------------------|--|
| Legend: | r = Reserved bit | y = Value set from Configuration bits on POR |
| R = Readable bit | P = Programmable bit | U = Unimplemented bit, read as '0' |
| -n = Value at POR | '1' = Bit is set | '0' = Bit is cleared |
| | | x = Bit is unknown |

bit 31 **Reserved:** The reset value of this bit is the same as DEVSIGN0<31>.

bit 30 **EJTAGBEN:** EJTAG Boot Enable bit

- 1 = Normal EJTAG functionality
- 0 = Reduced EJTAG functionality

bit 29-22 **Reserved:** Write as '1'

bit 21 **POSCBOOST:** Primary Oscillator Boost Kick Start Enable bit

- 1 = Boost the kick start of the oscillator
- 0 = Normal start of the oscillator

bit 20-19 **POSCGAIN<1:0>:** Primary Oscillator Gain Control bits

- 11 = 2x gain setting
- 10 = 1.5x gain setting
- 01 = 0.5x gain setting
- 00 = 1x gain setting

bit 18 **SOSCBOOST:** Secondary Oscillator Boost Kick Start Enable bit

- 1 = Boost the kick start of the oscillator
- 0 = Normal start of the oscillator

bit 17-16 **SOSCGAIN<1:0>:** Secondary Oscillator Gain Control bits

- 11 = 2x gain setting
- 10 = 1.5x gain setting
- 01 = 0.5x gain setting
- 00 = 1x gain setting

bit 15 **SMCLR:** Soft Master Clear Enable bit

- 1 = MCLR pin generates a normal system Reset
- 0 = MCLR pin generates a POR Reset

bit 14-12 **DBGPER<2:0>:** Debug Mode CPU Access Permission bits

- 1xx = Allow CPU access to Permission Group 2 permission regions
- x1x = Allow CPU access to Permission Group 1 permission regions
- xx1 = Allow CPU access to Permission Group 0 permission regions
- 0xx = Deny CPU access to Permission Group 2 permission regions
- x0x = Deny CPU access to Permission Group 1 permission regions
- xx0 = Deny CPU access to Permission Group 0 permission regions

When the CPU is in Debug mode and the CPU1PG<1:0> bits (CFGPG<1:0>) are set to a denied permission group as defined by DBGPER<2:0>, the transaction request is assigned Group 3 permissions.

bit 11 **Reserved:** This bit is controlled by debugger/emulator development tools and should not be modified by the user.

Note 1: This bit sets the value of the JTAGEN bit in the CFGCON register.

PIC32MZ Embedded Connectivity with Floating Point Unit (EF) Family

REGISTER 34-3: DEVCFG0/ADEVCFG0: DEVICE CONFIGURATION WORD 0 (CONTINUED)

- bit 10 **FSLEEP:** Flash Sleep Mode bit
1 = Flash is powered down when the device is in Sleep mode
0 = Flash remains powered when the device is in Sleep mode
- bit 9-8 **FECCCON<1:0>:** Dynamic Flash ECC Configuration bits
Upon a device Reset, the value of these bits is copied to the ECCCON<1:0> bits (CFGCON<5:4>).
11 = ECC and dynamic ECC are disabled (ECCCON<1:0> bits are writable)
10 = ECC and dynamic ECC are disabled (ECCCON<1:0> bits are locked)
01 = Dynamic Flash ECC is enabled (ECCCON<1:0> bits are locked)
00 = Flash ECC is enabled (ECCCON<1:0> bits are locked; disables word Flash writes)
- bit 7 **Reserved:** Write as '1'
- bit 6 **BOOTISA:** Boot ISA Selection bit
1 = Boot code and Exception code is MIPS32®
(ISAONEXC bit is set to '0' and the ISA<1:0> bits are set to '10' in the CP0 Config3 register)
0 = Boot code and Exception code is microMIPS™
(ISAONEXC bit is set to '1' and the ISA<1:0> bits are set to '11' in the CP0 Config3 register)
- bit 5 **TRCEN:** Trace Enable bit
1 = Trace features in the CPU are enabled
0 = Trace features in the CPU are disabled
- bit 4-3 **ICESEL<1:0>:** In-Circuit Emulator/Debugger Communication Channel Select bits
11 = PGEC1/PGED1 pair is used
10 = PGEC2/PGED2 pair is used
01 = Reserved
00 = Reserved
- bit 2 **JTAGEN:** JTAG Enable bit⁽¹⁾
1 = JTAG is enabled
0 = JTAG is disabled
- bit 1-0 **DEBUG<1:0>:** Background Debugger Enable bits (forced to '11' if code-protect is enabled)
1x = Debugger is disabled
0x = Debugger is enabled

Note 1: This bit sets the value of the JTAGEN bit in the CFGCON register.

PIC32MZ Embedded Connectivity with Floating Point Unit (EF) Family

REGISTER 34-4: DEVCFG1/ADEVCFG1: DEVICE CONFIGURATION WORD 1

| Bit Range | Bit 31/23/15/7 | Bit 30/22/14/6 | Bit 29/21/13/5 | Bit 28/20/12/4 | Bit 27/19/11/3 | Bit 26/18/10/2 | Bit 25/17/9/1 | Bit 24/16/8/0 | |
|-----------|----------------|----------------|----------------|----------------|----------------|----------------|----------------|---------------|--|
| 31:24 | R/P | R/P | R/P | R/P | R/P | R/P | R/P | R/P | |
| | FDMTEN | DMTCNT<4:0> | | | | | FWDTWINSZ<1:0> | | |
| 23:16 | R/P | R/P | R/P | R/P | R/P | R/P | R/P | R/P | |
| | FWDTEN | WINDIS | WDTSPGM | WDTPS<4:0> | | | | | |
| 15:8 | R/P | R/P | r-1 | r-1 | r-1 | R/P | R/P | R/P | |
| | FCKSM<1:0> | | — | — | — | OSCIOFNC | POSCMOD<1:0> | | |
| 7:0 | R/P | R/P | R/P | R/P | R/P | R/P | R/P | R/P | |
| | IESO | FSOSCEN | DMTINTV<2:0> | | | FNOSC<2:0> | | | |

| | | |
|-------------------|------------------|--|
| Legend: | r = Reserved bit | P = Programmable bit |
| R = Readable bit | W = Writable bit | U = Unimplemented bit, read as '0' |
| -n = Value at POR | '1' = Bit is set | '0' = Bit is cleared x = Bit is unknown |

- bit 31 **FDMTEN:** Deadman Timer enable bit
1 = Deadman Timer is enabled and *cannot* be disabled by software
0 = Deadman Timer is disabled and *can* be enabled by software
- bit 30-26 **DMTCNT<4:0>:** Deadman Timer Count Select bits
11111 = Reserved
•
•
11000 = Reserved
10111 = 2³¹ (2147483648)
10110 = 2³⁰ (1073741824)
10101 = 2²⁹ (536870912)
10100 = 2²⁸ (268435456)
•
•
•
00001 = 2⁹ (512)
00000 = 2⁸ (256)
- bit 25-24 **FWDTWINSZ<1:0>:** Watchdog Timer Window Size bits
11 = Window size is 25%
10 = Window size is 37.5%
01 = Window size is 50%
00 = Window size is 75%
- bit 23 **FWDTEN:** Watchdog Timer Enable bit
1 = Watchdog Timer is enabled and cannot be disabled by software
0 = Watchdog Timer is not enabled; it can be enabled in software
- bit 22 **WINDIS:** Watchdog Timer Window Enable bit
1 = Watchdog Timer is in non-Window mode
0 = Watchdog Timer is in Window mode
- bit 21 **WDTSPGM:** Watchdog Timer Stop During Flash Programming bit
1 = Watchdog Timer stops during Flash programming
0 = Watchdog Timer runs during Flash programming (for read/execute while programming Flash applications)

PIC32MZ Embedded Connectivity with Floating Point Unit (EF) Family

REGISTER 34-4: DEVCFG1/ADEVCFG1: DEVICE CONFIGURATION WORD 1 (CONTINUED)

bit 20-16 **WDTPS<4:0>**: Watchdog Timer Postscale Select bits

10100 = 1:1048576
10011 = 1:524288
10010 = 1:262144
10001 = 1:131072
10000 = 1:65536
01111 = 1:32768
01110 = 1:16384
01101 = 1:8192
01100 = 1:4096
01011 = 1:2048
01010 = 1:1024
01001 = 1:512
01000 = 1:256
00111 = 1:128
00110 = 1:64
00101 = 1:32
00100 = 1:16
00011 = 1:8
00010 = 1:4
00001 = 1:2
00000 = 1:1

All other combinations not shown result in operation = 10100

bit 15-14 **FCKSM<1:0>**: Clock Switching and Monitoring Selection Configuration bits

11 = Clock switching is enabled and clock monitoring is enabled
10 = Clock switching is disabled and clock monitoring is enabled
01 = Clock switching is enabled and clock monitoring is disabled
00 = Clock switching is disabled and clock monitoring is disabled

bit 13-11 **Reserved**: Write as '1'

bit 10 **OSCIOFNC**: CLKO Enable Configuration bit

1 = CLKO output disabled
0 = CLKO output signal active on the OSC2 pin; Primary Oscillator must be disabled or configured for the External Clock mode (EC) for the CLKO to be active (POSCMOD<1:0> = 11 or 00)

bit 9-8 **POSCMOD<1:0>**: Primary Oscillator Configuration bits

11 = Posc disabled
10 = HS Oscillator mode selected
01 = Reserved
00 = EC mode selected

bit 7 **IESO**: Internal External Switchover bit

1 = Internal External Switchover mode is enabled (Two-Speed Start-up is enabled)
0 = Internal External Switchover mode is disabled (Two-Speed Start-up is disabled)

bit 6 **FSOSCEN**: Secondary Oscillator Enable bit

1 = Enable Sosc
0 = Disable Sosc

bit 5-3 **DMTINTV<2:0>**: Deadman Timer Count Window Interval bits

111 = Window/Interval value is 127/128 counter value
110 = Window/Interval value is 63/64 counter value
101 = Window/Interval value is 31/32 counter value
100 = Window/Interval value is 15/16 counter value
011 = Window/Interval value is 7/8 counter value
010 = Window/Interval value is 3/4 counter value
001 = Window/Interval value is 1/2 counter value
000 = Window/Interval value is zero

PIC32MZ Embedded Connectivity with Floating Point Unit (EF) Family

REGISTER 34-4: DEVCFG1/ADEVCFG1: DEVICE CONFIGURATION WORD 1 (CONTINUED)

bit 2-0 **FNOSC<2:0>**: Oscillator Selection bits

- 111 = FRC divided by FRCDIV<2:0> bits (FRCDIV)
- 110 = Reserved
- 101 = LPRC
- 100 = Sosc
- 011 = Reserved
- 010 = Posc (HS, EC)
- 001 = SPLL
- 000 = FRC divided by FRCDIV<2:0> bits (FRCDIV)

PIC32MZ Embedded Connectivity with Floating Point Unit (EF) Family

REGISTER 34-5: DEVCFG2/ADEVCFG2: DEVICE CONFIGURATION WORD 2

| Bit Range | Bit 31/23/15/7 | Bit 30/22/14/6 | Bit 29/21/13/5 | Bit 28/20/12/4 | Bit 27/19/11/3 | Bit 26/18/10/2 | Bit 25/17/9/1 | Bit 24/16/8/0 |
|-----------|----------------|----------------|----------------|----------------|----------------|----------------|---------------|---------------|
| 31:24 | r-1 | R/P | r-1 | r-1 | r-1 | r-1 | r-1 | r-1 |
| | — | UPLLFSEL | — | — | — | — | — | — |
| 23:16 | r-1 | r-1 | r-1 | r-1 | r-1 | R/P | R/P | R/P |
| | — | — | — | — | — | FPLLODIV<2:0> | | |
| 15:8 | r-1 | R/P | R/P | R/P | R/P | R/P | R/P | R/P |
| | — | FPLLMULT<6:0> | | | | | | |
| 7:0 | R/P | R/P | R/P | R/P | r-1 | R/P | R/P | R/P |
| | FPLLICK | FPLLNRNG<2:0> | | | — | FPLLIDIV<2:0> | | |

| | | |
|-------------------|------------------|--|
| Legend: | r = Reserved bit | P = Programmable bit |
| R = Readable bit | W = Writable bit | U = Unimplemented bit, read as '0' |
| -n = Value at POR | '1' = Bit is set | '0' = Bit is cleared x = Bit is unknown |

bit 31 **Reserved:** Write as '1'

bit 30 **UPLLFSEL:** USB PLL Input Frequency Select bit
 1 = UPLL input clock is 24 MHz
 0 = UPLL input clock is 12 MHz

bit 29-19 **Reserved:** Write as '1'

bit 18-16 **FPLLODIV<2:0>:** Default System PLL Output Divisor bits
 111 = PLL output divided by 32
 110 = PLL output divided by 32
 101 = PLL output divided by 32
 100 = PLL output divided by 16
 011 = PLL output divided by 8
 010 = PLL output divided by 4
 001 = PLL output divided by 2
 000 = PLL output divided by 2

bit 15 **Reserved:** Write as '1'

bit 14-8 **FPLLMULT<6:0>:** System PLL Feedback Divider bits
 11111111 = Multiply by 128
 11111110 = Multiply by 127
 11111101 = Multiply by 126
 11111100 = Multiply by 125
 •
 •
 •
 00000000 = Multiply by 1

bit 7 **FPLLICK:** System PLL Input Clock Select bit
 1 = FRC is selected as input to the System PLL
 0 = POSC is selected as input to the System PLL

bit 6-4 **FPLLNRNG<2:0>:** System PLL Divided Input Clock Frequency Range bits
 111 = Reserved
 110 = Reserved
 101 = 34-64 MHz
 100 = 21-42 MHz
 011 = 13-26 MHz
 010 = 8-16 MHz
 001 = 5-10 MHz
 000 = Bypass

PIC32MZ Embedded Connectivity with Floating Point Unit (EF) Family

REGISTER 34-5: DEVCFG2/ADEVCFG2: DEVICE CONFIGURATION WORD 2 (CONTINUED)

bit 3 **Reserved:** Write as '1'

bit 2-0 **FPLLIDIV<2:0>:** PLL Input Divider bits

111 = Divide by 8

110 = Divide by 7

101 = Divide by 6

100 = Divide by 5

011 = Divide by 4

010 = Divide by 3

001 = Divide by 2

000 = Divide by 1

PIC32MZ Embedded Connectivity with Floating Point Unit (EF) Family

REGISTER 34-6: DEVCFG3/ADEVCFG3: DEVICE CONFIGURATION WORD 3

| Bit Range | Bit 31/23/15/7 | Bit 30/22/14/6 | Bit 29/21/13/5 | Bit 28/20/12/4 | Bit 27/19/11/3 | Bit 26/18/10/2 | Bit 25/17/9/1 | Bit 24/16/8/0 |
|-----------|----------------|----------------|----------------|----------------|----------------|----------------|---------------|---------------|
| 31:24 | r-1 | R/P | R/P | R/P | R/P | r-1 | R/P | R/P |
| | — | FUSBIDIO | IOL1WAY | PMDL1WAY | PGL1WAY | — | FETHIO | FMIEN |
| 23:16 | r-1 | r-1 | r-1 | r-1 | r-1 | r-1 | r-1 | r-1 |
| | — | — | — | — | — | — | — | — |
| 15:8 | R/P | R/P | R/P | R/P | R/P | R/P | R/P | R/P |
| | USERID<15:8> | | | | | | | |
| 7:0 | R/P | R/P | R/P | R/P | R/P | R/P | R/P | R/P |
| | USERID<7:0> | | | | | | | |

| | | |
|-------------------|------------------|--|
| Legend: | r = Reserved bit | P = Programmable bit |
| R = Readable bit | W = Writable bit | U = Unimplemented bit, read as '0' |
| -n = Value at POR | '1' = Bit is set | '0' = Bit is cleared x = Bit is unknown |

- bit 31 **Reserved:** Write as '1'
- bit 30 **FUSBIDIO:** USB USBID Selection bit
 - 1 = USBID pin is controlled by the USB module
 - 0 = USBID pin is controlled by the port function
 If USBMD is '1', USBID reverts to port control.
- bit 29 **IOL1WAY:** Peripheral Pin Select Configuration bit
 - 1 = Allow only one reconfiguration
 - 0 = Allow multiple reconfigurations
- bit 28 **PMDL1WAY:** Peripheral Module Disable Configuration bit
 - 1 = Allow only one reconfiguration
 - 0 = Allow multiple reconfigurations
- bit 27 **PGL1WAY:** Permission Group Lock One Way Configuration bit
 - 1 = Allow only one reconfiguration
 - 0 = Allow multiple reconfigurations
- bit 26 **Reserved:** Write as '1'
- bit 25 **FETHIO:** Ethernet I/O Pin Selection Configuration bit
 - 1 = Default Ethernet I/O pins
 - 0 = Alternate Ethernet I/O pins
 This bit is ignored for devices that do not have an alternate Ethernet pin selection.
- bit 24 **FMIEN:** Ethernet MII Enable Configuration bit
 - 1 = MII is enabled
 - 0 = RMII is enabled
- bit 23-16 **Reserved:** Write as '1'
- bit 15-0 **USERID<15:0>:** This is a 16-bit value that is user-defined and is readable via ICSP™ and JTAG

PIC32MZ Embedded Connectivity with Floating Point Unit (EF) Family

REGISTER 34-7: CFGCON: CONFIGURATION CONTROL REGISTER

| Bit Range | Bit 31/23/15/7 | Bit 30/22/14/6 | Bit 29/21/13/5 | Bit 28/20/12/4 | Bit 27/19/11/3 | Bit 26/18/10/2 | Bit 25/17/9/1 | Bit 24/16/8/0 |
|-----------|----------------|----------------|-----------------------|------------------------|-----------------------|----------------|-----------------------|-----------------------|
| 31:24 | U-0 | U-0 | U-0 | U-0 | U-0 | U-0 | R/W-0 | R/W-0 |
| | — | — | — | — | — | — | DMAPRI ⁽¹⁾ | CPUPRI ⁽¹⁾ |
| 23:16 | U-0 | U-0 | U-0 | U-0 | U-0 | U-0 | R/W-0 | R/W-0 |
| | — | — | — | — | — | — | ICACLK ⁽¹⁾ | OCACLK ⁽¹⁾ |
| 15:8 | U-0 | U-0 | R/W-0 | R/W-0 | R/W-0 | U-0 | U-0 | R/W-0 |
| | — | — | IOLOCK ⁽¹⁾ | PMDLOCK ⁽¹⁾ | PGLOCK ⁽¹⁾ | — | — | USBSEN ⁽¹⁾ |
| 7:0 | R/W-0 | U-0 | R/W-1 | R/W-1 | R/W-1 | R/W-0 | U-0 | R/W-1 |
| | IOANCPEN | — | ECCCON<1:0> | | JTAGEN | TROEN | — | TDOEN |

Legend:

R = Readable bit
-n = Value at POR

W = Writable bit
'1' = Bit is set

U = Unimplemented bit, read as '0'
'0' = Bit is cleared
x = Bit is unknown

bit 31-26 **Unimplemented:** Read as '0'

bit 25 **DMAPRI:** DMA Read and DMA Write Arbitration Priority to SRAM bit⁽¹⁾

- 1 = DMA gets High Priority access to SRAM
- 0 = DMA uses Least Recently Serviced Arbitration (same as other initiators)

bit 24 **CPUPRI:** CPU Arbitration Priority to SRAM When Servicing an Interrupt bit⁽¹⁾

- 1 = CPU gets High Priority access to SRAM
- 0 = CPU uses Least Recently Serviced Arbitration (same as other initiators)

bit 23-18 **Unimplemented:** Read as '0'

bit 17 **ICACLK:** Input Capture Alternate Clock Selection bit⁽¹⁾

- 1 = Input Capture modules use an alternative Timer pair as their timebase clock
- 0 = All Input Capture modules use Timer2/3 as their timebase clock

bit 16 **OCACLK:** Output Compare Alternate Clock Selection bit⁽¹⁾

- 1 = Output Compare modules use an alternative Timer pair as their timebase clock
- 0 = All Output Compare modules use Timer2/3 as their timebase clock

bit 15-14 **Unimplemented:** Read as '0'

bit 13 **IOLOCK:** Peripheral Pin Select Lock bit⁽¹⁾

- 1 = Peripheral Pin Select is locked. Writes to PPS registers are not allowed
- 0 = Peripheral Pin Select is not locked. Writes to PPS registers are allowed

bit 12 **PMDLOCK:** Peripheral Module Disable bit⁽¹⁾

- 1 = Peripheral module is locked. Writes to PMD registers are not allowed
- 0 = Peripheral module is not locked. Writes to PMD registers are allowed

bit 11 **PGLOCK:** Permission Group Lock bit⁽¹⁾

- 1 = Permission Group registers are locked. Writes to PG registers are not allowed
- 0 = Permission Group registers are not locked. Writes to PG registers are allowed

bit 10-9 **Unimplemented:** Read as '0'

bit 8 **USBSEN:** USB Suspend Sleep Enable bit⁽¹⁾

- Enables features for USB PHY clock shutdown in Sleep mode.
- 1 = USB PHY clock is shut down when Sleep mode is active
- 0 = USB PHY clock continues to run when Sleep is active

Note 1: To change this bit, the unlock sequence must be performed. Refer to **Section 42. "Oscillators with Enhanced PLL"** in the *"PIC32 Family Reference Manual"* for details.

PIC32MZ Embedded Connectivity with Floating Point Unit (EF) Family

REGISTER 34-7: CFGCON: CONFIGURATION CONTROL REGISTER (CONTINUED)

- bit 7 **IOANCPEN:** I/O Analog Charge Pump Enable bit
The analog IO charge pump improves analog performance when the device is operating at lower voltages. However, the charge pumps consume additional current.
1 = Charge pump enabled
0 = Charge pump disabled
- bit 6 **Unimplemented:** Read as '0'
- bit 5-4 **ECCCON<1:0>:** Flash ECC Configuration bits
11 = ECC and dynamic ECC are disabled (ECCCON<1:0> bits are writable)
10 = ECC and dynamic ECC are disabled (ECCCON<1:0> bits are locked)
01 = Dynamic Flash ECC is enabled (ECCCON<1:0> bits are locked)
00 = Flash ECC is enabled (ECCCON<1:0> bits are locked; disables word Flash writes)
- bit 3 **JTAGEN:** JTAG Port Enable bit
1 = Enable the JTAG port
0 = Disable the JTAG port
- bit 2 **TROEN:** Trace Output Enable bit
1 = Enable trace outputs and start trace clock (trace probe must be present)
0 = Disable trace outputs and stop trace clock
- bit 1 **Unimplemented:** Read as '0'
- bit 0 **TDOEN:** TDO Enable for 2-Wire JTAG
1 = 2-wire JTAG protocol uses TDO
0 = 2-wire JTAG protocol does not use TDO

Note 1: To change this bit, the unlock sequence must be performed. Refer to **Section 42. "Oscillators with Enhanced PLL"** in the *"PIC32 Family Reference Manual"* for details.

PIC32MZ Embedded Connectivity with Floating Point Unit (EF) Family

REGISTER 34-8: CFGEBIA: EXTERNAL BUS INTERFACE ADDRESS PIN CONFIGURATION REGISTER

| Bit Range | Bit 31/23/15/7 | Bit 30/22/14/6 | Bit 29/21/13/5 | Bit 28/20/12/4 | Bit 27/19/11/3 | Bit 26/18/10/2 | Bit 25/17/9/1 | Bit 24/16/8/0 |
|-----------|----------------|----------------|----------------|----------------|----------------|----------------|---------------|---------------|
| 31:24 | R/W-0 | U-0 | U-0 | U-0 | U-0 | U-0 | U-0 | U-0 |
| | EBIPINEN | — | — | — | — | — | — | — |
| 23:16 | R/W-0 | R/W-0 | R/W-0 | R/W-0 | R/W-0 | R/W-0 | R/W-0 | R/W-0 |
| | EBIA23EN | EBIA22EN | EBIA21EN | EBIA20EN | EBIA19EN | EBIA18EN | EBIA17EN | EBIA16EN |
| 15:8 | R/W-0 | R/W-0 | R/W-0 | R/W-0 | R/W-0 | R/W-0 | R/W-0 | R/W-0 |
| | EBIA15EN | EBIA14EN | EBIA13EN | EBIA12EN | EBIA11EN | EBIA10EN | EBIA9EN | EBIA8EN |
| 7:0 | R/W-0 | R/W-0 | R/W-0 | R/W-0 | R/W-0 | R/W-0 | R/W-0 | R/W-0 |
| | EBIA7EN | EBIA6EN | EBIA5EN | EBIA4EN | EBIA3EN | EBIA2EN | EBIA1EN | EBIA0EN |

Legend:

R = Readable bit

W = Writable bit

U = Unimplemented bit, read as '0'

-n = Value at POR

'1' = Bit is set

'0' = Bit is cleared

x = Bit is unknown

bit 31 **EBIPINEN:** EBI Pin Enable bit

1 = EBI controls access of pins shared with PMP

0 = Pins shared with EBI are available for general use

bit 30-24 **Unimplemented:** Read as '0'

bit 23-0 **EBIA23EN:EBIA0EN:** EBI Address Pin Enable bits

1 = EBIAx pin is enabled for use by EBI

0 = EBIAx pin has is available for general use

Note: When EBIMD = 1, the bits in this register are ignored and the pins are available for general use.

PIC32MZ Embedded Connectivity with Floating Point Unit (EF) Family

REGISTER 34-9: CFGEBIC: EXTERNAL BUS INTERFACE CONTROL PIN CONFIGURATION REGISTER

| Bit Range | Bit 31/23/15/7 | Bit 30/22/14/6 | Bit 29/21/13/5 | Bit 28/20/12/4 | Bit 27/19/11/3 | Bit 26/18/10/2 | Bit 25/17/9/1 | Bit 24/16/8/0 |
|-----------|----------------|----------------|----------------|----------------|----------------|----------------|---------------|---------------|
| 31:24 | R/W-0 | R/W-0 | R/W-0 | U-0 | R/W-0 | R/W-0 | R/W-0 | U-0 |
| | EBI RDYINV3 | EBI RDYINV2 | EBI RDYIN1 | — | EBI RDYEN3 | EBI RDYEN2 | EBI RDYEN1 | — |
| 23:16 | U-0 | U-0 | U-0 | U-0 | U-0 | U-0 | R/W-0 | R/W-0 |
| | — | — | — | — | — | — | EBIRDYLVL | EBIRPEN |
| 15:8 | U-0 | U-0 | R/W-0 | R/W-0 | U-0 | U-0 | R/W-0 | R/W-0 |
| | — | — | EBIWEEN | EBIOEEN | — | — | EBIBSEN1 | EBIBSEN0 |
| 7:0 | R/W-0 | R/W-0 | R/W-0 | R/W-0 | U-0 | U-0 | R/W-0 | R/W-0 |
| | EBICSEN3 | EBICSEN2 | EBICSEN1 | EBICSEN0 | — | — | EBIDEN1 | EBIDEN0 |

Legend:

R = Readable bit
-n = Value at POR

W = Writable bit
'1' = Bit is set

U = Unimplemented bit, read as '0'
'0' = Bit is cleared
x = Bit is unknown

- bit 31 **EBIRDYINV3:** EBIRDY3 Inversion Control bit
1 = Invert EBIRDY3 pin before use
0 = Do not invert EBIRDY3 pin before use
- bit 30 **EBIRDYINV2:** EBIRDY3 Inversion Control bit
1 = Invert EBIRDY3 pin before use
0 = Do not invert EBIRDY3 pin before use
- bit 29 **EBIRDYINV1:** EBIRDY2 Inversion Control bit
1 = Invert EBIRDY2 pin before use
0 = Do not invert EBIRDY2 pin before use
- bit 28 **Unimplemented:** Read as '0'
- bit 27 **EBIRDYEN3:** EBIRDY3 Pin Enable bit
1 = EBIRDY3 pin is enabled for use by the EBI module
0 = EBIRDY3 pin is available for general use
- bit 26 **EBIRDYEN2:** EBIRDY3 Pin Enable bit
1 = EBIRDY3 pin is enabled for use by the EBI module
0 = EBIRDY3 pin is available for general use
- bit 25 **EBIRDYEN1:** EBIRDY2 Pin Enable bit
1 = EBIRDY2 pin is enabled for use by the EBI module
0 = EBIRDY2 pin is available for general use
- bit 24-18 **Unimplemented:** Read as '0'
- bit 17 **EBIRDYLVL:** EBIRDYx Pin Sensitivity Control bit
1 = Use level detect for EBIRDYx pins
0 = Use edge detect for EBIRDYx pins
- bit 16 **EBIRPEN:** $\overline{\text{EBIRP}}$ Pin Sensitivity Control bit
1 = $\overline{\text{EBIRP}}$ pin is enabled for use by the EBI module
0 = $\overline{\text{EBIRP}}$ pin is available for general use
- bit 15-14 **Unimplemented:** Read as '0'
- bit 13 **EBIWEEN:** $\overline{\text{EBIWE}}$ Pin Enable bit
1 = $\overline{\text{EBIWE}}$ pin is enabled for use by the EBI module
0 = $\overline{\text{EBIWE}}$ pin is available for general use

Note: When EBIMD = 1, the bits in this register are ignored and the pins are available for general use.

PIC32MZ Embedded Connectivity with Floating Point Unit (EF) Family

REGISTER 34-9: CFGEBIC: EXTERNAL BUS INTERFACE CONTROL PIN CONFIGURATION REGISTER (CONTINUED)

- bit 12 **EBIOEEN:** $\overline{\text{EBIOE}}$ Pin Enable bit
1 = $\overline{\text{EBIOE}}$ pin is enabled for use by the EBI module
0 = $\overline{\text{EBIOE}}$ pin is available for general use
- bit 11-10 **Unimplemented:** Read as '0'
- bit 9 **EBIBSEN1:** $\overline{\text{EBIBS1}}$ Pin Enable bit
1 = $\overline{\text{EBIBS1}}$ pin is enabled for use by the EBI module
0 = $\overline{\text{EBIBS1}}$ pin is available for general use
- bit 8 **EBIBSEN0:** $\overline{\text{EBIBS0}}$ Pin Enable bit
1 = $\overline{\text{EBIBS0}}$ pin is enabled for use by the EBI module
0 = $\overline{\text{EBIBS0}}$ pin is available for general use
- bit 7 **EBICS3EN:** $\overline{\text{EBICS3}}$ Pin Enable bit
1 = $\overline{\text{EBICS3}}$ pin is enabled for use by the EBI module
0 = $\overline{\text{EBICS3}}$ pin is available for general use
- bit 6 **EBICS2EN:** $\overline{\text{EBICS2}}$ Pin Enable bit
1 = $\overline{\text{EBICS2}}$ pin is enabled for use by the EBI module
0 = $\overline{\text{EBICS2}}$ pin is available for general use
- bit 5 **EBICS1EN:** $\overline{\text{EBICS1}}$ Pin Enable bit
1 = $\overline{\text{EBICS1}}$ pin is enabled for use by the EBI module
0 = $\overline{\text{EBICS1}}$ pin is available for general use
- bit 4 **EBICS0EN:** $\overline{\text{EBICS0}}$ Pin Enable bit
1 = $\overline{\text{EBICS0}}$ pin is enabled for use by the EBI module
0 = $\overline{\text{EBICS0}}$ pin is available for general use
- bit 3-2 **Unimplemented:** Read as '0'
- bit 1 **EBIDEN1:** EBI Data Upper Byte Pin Enable bit
1 = EBID<15:8> pins are enabled for use by the EBI module
0 = EBID<15:8> pins have reverted to general use
- bit 0 **EBIDEN0:** EBI Data Lower Byte Pin Enable bit
1 = EBID<7:0> pins are enabled for use by the EBI module
0 = EBID<7:0> pins have reverted to general use

Note: When EBIMD = 1, the bits in this register are ignored and the pins are available for general use.

PIC32MZ Embedded Connectivity with Floating Point Unit (EF) Family

REGISTER 34-10: CFGPG: PERMISSION GROUP CONFIGURATION REGISTER

| Bit Range | Bit 31/23/15/7 | Bit 30/22/14/6 | Bit 29/21/13/5 | Bit 28/20/12/4 | Bit 27/19/11/3 | Bit 26/18/10/2 | Bit 25/17/9/1 | Bit 24/16/8/0 |
|-----------|----------------|----------------|----------------|----------------|----------------|----------------|---------------|---------------|
| 31:24 | U-0 | U-0 | U-0 | U-0 | U-0 | U-0 | R/W-0 | R/W-0 |
| | — | — | — | — | — | — | CRYPTPG<1:0> | |
| 23:16 | R/W-0 | R/W-0 | R/W-0 | R/W-0 | U-0 | U-0 | R/W-0 | R/W-0 |
| | FCPG<1:0> | | SQI1PG<1:0> | | — | — | ETHPG<1:0> | |
| 15:8 | R/W-0 | R/W-0 | R/W-0 | R/W-0 | U-0 | U-0 | R/W-0 | R/W-0 |
| | CAN2PG<1:0> | | CAN1PG<1:0> | | — | — | USBPG<1:0> | |
| 7:0 | U-0 | U-0 | R/W-0 | R/W-0 | U-0 | U-0 | R/W-0 | R/W-0 |
| | — | — | DMPG<1:0> | | — | — | CPUPG<1:0> | |

Legend:

R = Readable bit
-n = Value at POR

W = Writable bit
'1' = Bit is set

U = Unimplemented bit, read as '0'
'0' = Bit is cleared

- bit 31-26 **Unimplemented:** Read as '0'
- bit 25-24 **CRYPTPG<1:0>**: Crypto Engine Permission Group bits
 - 11 = Initiator is assigned to Permission Group 3
 - 10 = Initiator is assigned to Permission Group 2
 - 01 = Initiator is assigned to Permission Group 1
 - 00 = Initiator is assigned to Permission Group 0
- bit 23-22 **FCPG<1:0>**: Flash Control Permission Group bits
Same definition as bits 25-24.
- bit 21-20 **SQI1PG<1:0>**: SQI Module Permission Group bits
Same definition as bits 25-24.
- bit 19-18 **Unimplemented:** Read as '0'
- bit 17-16 **ETHPG<1:0>**: Ethernet Module Permission Group bits
Same definition as bits 25-24.
- bit 15-14 **CAN2PG<1:0>**: CAN2 Module Permission Group bits
Same definition as bits 25-24.
- bit 13-12 **CAN1PG<1:0>**: CAN1 Module Permission Group bits
Same definition as bits 25-24.
- bit 11-10 **Unimplemented:** Read as '0'
- bit 9-8 **USBPG<1:0>**: USB Module Permission Group bits
Same definition as bits 25-24.
- bit 7-6 **Unimplemented:** Read as '0'
- bit 5-4 **DMPG<1:0>**: DMA Module Permission Group bits
Same definition as bits 25-24.
- bit 3-2 **Unimplemented:** Read as '0'
- bit 1-0 **CPUPG<1:0>**: CPU Permission Group bits
Same definition as bits 25-24.

PIC32MZ Embedded Connectivity with Floating Point Unit (EF) Family

REGISTER 34-11: DEVID: DEVICE AND REVISION ID REGISTER

| Bit Range | Bit 31/23/15/7 | Bit 30/22/14/6 | Bit 29/21/13/5 | Bit 28/20/12/4 | Bit 27/19/11/3 | Bit 26/18/10/2 | Bit 25/17/9/1 | Bit 24/16/8/0 |
|-----------|-----------------------------|----------------|----------------|----------------|-----------------------------|----------------|---------------|---------------|
| 31:24 | R | R | R | R | R | R | R | R |
| | VER<3:0> ⁽¹⁾ | | | | DEVID<27:24> ⁽¹⁾ | | | |
| 23:16 | R | R | R | R | R | R | R | R |
| | DEVID<23:16> ⁽¹⁾ | | | | | | | |
| 15:8 | R | R | R | R | R | R | R | R |
| | DEVID<15:8> ⁽¹⁾ | | | | | | | |
| 7:0 | R | R | R | R | R | R | R | R |
| | DEVID<7:0> ⁽¹⁾ | | | | | | | |

Legend:

R = Readable bit W = Writable bit U = Unimplemented bit, read as '0'
 -n = Value at POR '1' = Bit is set '0' = Bit is cleared x = Bit is unknown

bit 31-28 **VER<3:0>**: Revision Identifier bits⁽¹⁾

bit 27-0 **DEVID<27:0>**: Device ID⁽¹⁾

Note 1: See the "PIC32 Flash Programming Specification" (DS60001145) for a list of Revision and Device ID values.

REGISTER 34-12: DEVS_N: DEVICE SERIAL NUMBER REGISTER 'x' ('x' = 0, 1)

| Bit Range | Bit 31/23/15/7 | Bit 30/22/14/6 | Bit 29/21/13/5 | Bit 28/20/12/4 | Bit 27/19/11/3 | Bit 26/18/10/2 | Bit 25/17/9/1 | Bit 24/16/8/0 |
|-----------|----------------|----------------|----------------|----------------|----------------|----------------|---------------|---------------|
| 31:24 | R | R | R | R | R | R | R | R |
| | SN<31:24> | | | | | | | |
| 23:16 | R | R | R | R | R | R | R | R |
| | SN<23:16> | | | | | | | |
| 15:8 | R | R | R | R | R | R | R | R |
| | SN<15:8> | | | | | | | |
| 7:0 | R | R | R | R | R | R | R | R |
| | SN<7:0> | | | | | | | |

Legend:

R = Readable bit W = Writable bit U = Unimplemented bit, read as '0'
 -n = Value at POR '1' = Bit is set '0' = Bit is cleared x = Bit is unknown

bit 31-0 **SN<31:0>**: Device Unique Serial Number bits

34.3 On-Chip Voltage Regulator

The core and digital logic for all PIC32MZ EF devices is designed to operate at a nominal 1.8V. To simplify system designs, devices in the PIC32MZ EF family incorporate an on-chip regulator providing the required core logic voltage from VDD.

34.3.1 ON-CHIP REGULATOR AND POR

It takes a fixed delay for the on-chip regulator to generate an output. During this time, designated as TPU, code execution is disabled. TPU is applied every time the device resumes operation after any power-down, including Sleep mode.

34.3.2 ON-CHIP REGULATOR AND BOR

PIC32MZ EF devices also have a simple brown-out capability. If the voltage supplied to the regulator is inadequate to maintain a regulated level, the regulator Reset circuitry will generate a Brown-out Reset. This event is captured by the BOR flag bit (RCON<1>). The brown-out voltage levels are specific in [Section 37.1 “DC Characteristics”](#).

34.4 On-chip Temperature Sensor

PIC32MZ EF devices include a temperature sensor that provides accurate measurement of a device’s junction temperature (see [Section 37.2 “AC Characteristics and Timing Parameters”](#) for more information).

The temperature sensor is connected to the ADC module and can be measured using the shared S&H circuit (see [Section 28.0 “12-bit High-Speed Successive Approximation Register \(SAR\) Analog-to-Digital Converter \(ADC\)”](#) for more information).

34.5 Programming and Diagnostics

PIC32MZ EF devices provide a complete range of programming and diagnostic features that can increase the flexibility of any application using them. These features allow system designers to include:

- Simplified field programmability using two-wire In-Circuit Serial Programming™ (ICSP™) interfaces
- Debugging using ICSP
- Programming and debugging capabilities using the EJTAG extension of JTAG
- JTAG boundary scan testing for device and board diagnostics

PIC32 devices incorporate two programming and diagnostic modules, and a trace controller, that provide a range of functions to the application developer.

FIGURE 34-1: BLOCK DIAGRAM OF PROGRAMMING, DEBUGGING AND TRACE PORTS

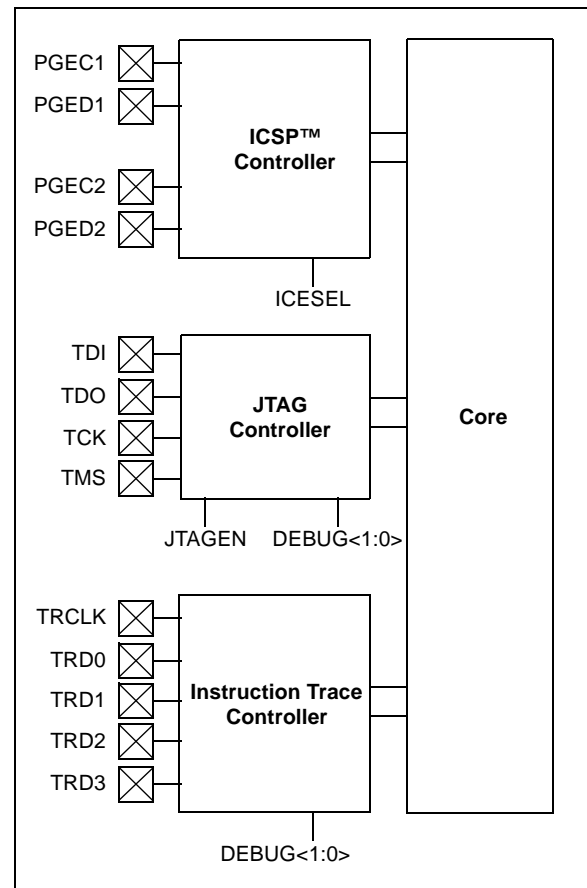

PIC32MZ Embedded Connectivity with Floating Point Unit (EF) Family

NOTES:

35.0 INSTRUCTION SET

The PIC32MZ EF family instruction set complies with the MIPS32[®] Release 5 instruction set architecture. The PIC32MZ EF device family *does not* support the following features:

- Core extend instructions
- Coprocessor 2 instructions

Note: Refer to “MIPS32[®] Architecture for Programmers Volume II: The MIPS32[®] Instruction Set” at www.imgtec.com for more information.

PIC32MZ Embedded Connectivity with Floating Point Unit (EF) Family

NOTES:

36.0 DEVELOPMENT SUPPORT

The PIC[®] microcontrollers (MCU) and dsPIC[®] digital signal controllers (DSC) are supported with a full range of software and hardware development tools:

- Integrated Development Environment
 - MPLAB[®] X IDE Software
- Compilers/Assemblers/Linkers
 - MPLAB XC Compiler
 - MPASM[™] Assembler
 - MPLINK[™] Object Linker/
MPLIB[™] Object Librarian
 - MPLAB Assembler/Linker/Librarian for Various Device Families
- Simulators
 - MPLAB X SIM Software Simulator
- Emulators
 - MPLAB REAL ICE[™] In-Circuit Emulator
- In-Circuit Debuggers/Programmers
 - MPLAB ICD 3
 - PICKit[™] 3
- Device Programmers
 - MPLAB PM3 Device Programmer
- Low-Cost Demonstration/Development Boards, Evaluation Kits and Starter Kits
- Third-party development tools

36.1 MPLAB X Integrated Development Environment Software

The MPLAB X IDE is a single, unified graphical user interface for Microchip and third-party software, and hardware development tool that runs on Windows[®], Linux and Mac OS[®] X. Based on the NetBeans IDE, MPLAB X IDE is an entirely new IDE with a host of free software components and plug-ins for high-performance application development and debugging. Moving between tools and upgrading from software simulators to hardware debugging and programming tools is simple with the seamless user interface.

With complete project management, visual call graphs, a configurable watch window and a feature-rich editor that includes code completion and context menus, MPLAB X IDE is flexible and friendly enough for new users. With the ability to support multiple tools on multiple projects with simultaneous debugging, MPLAB X IDE is also suitable for the needs of experienced users.

Feature-Rich Editor:

- Color syntax highlighting
- Smart code completion makes suggestions and provides hints as you type
- Automatic code formatting based on user-defined rules
- Live parsing

User-Friendly, Customizable Interface:

- Fully customizable interface: toolbars, toolbar buttons, windows, window placement, etc.
- Call graph window

Project-Based Workspaces:

- Multiple projects
- Multiple tools
- Multiple configurations
- Simultaneous debugging sessions

File History and Bug Tracking:

- Local file history feature
- Built-in support for Bugzilla issue tracker

36.2 MPLAB XC Compilers

The MPLAB XC Compilers are complete ANSI C compilers for all of Microchip's 8, 16, and 32-bit MCU and DSC devices. These compilers provide powerful integration capabilities, superior code optimization and ease of use. MPLAB XC Compilers run on Windows, Linux or MAC OS X.

For easy source level debugging, the compilers provide debug information that is optimized to the MPLAB X IDE.

The free MPLAB XC Compiler editions support all devices and commands, with no time or memory restrictions, and offer sufficient code optimization for most applications.

MPLAB XC Compilers include an assembler, linker and utilities. The assembler generates relocatable object files that can then be archived or linked with other relocatable object files and archives to create an executable file. MPLAB XC Compiler uses the assembler to produce its object file. Notable features of the assembler include:

- Support for the entire device instruction set
- Support for fixed-point and floating-point data
- Command-line interface
- Rich directive set
- Flexible macro language
- MPLAB X IDE compatibility

36.3 MPASM Assembler

The MPASM Assembler is a full-featured, universal macro assembler for PIC10/12/16/18 MCUs.

The MPASM Assembler generates relocatable object files for the MPLINK Object Linker, Intel® standard HEX files, MAP files to detail memory usage and symbol reference, absolute LST files that contain source lines and generated machine code, and COFF files for debugging.

The MPASM Assembler features include:

- Integration into MPLAB X IDE projects
- User-defined macros to streamline assembly code
- Conditional assembly for multipurpose source files
- Directives that allow complete control over the assembly process

36.4 MPLINK Object Linker/ MPLIB Object Librarian

The MPLINK Object Linker combines relocatable objects created by the MPASM Assembler. It can link relocatable objects from precompiled libraries, using directives from a linker script.

The MPLIB Object Librarian manages the creation and modification of library files of precompiled code. When a routine from a library is called from a source file, only the modules that contain that routine will be linked in with the application. This allows large libraries to be used efficiently in many different applications.

The object linker/library features include:

- Efficient linking of single libraries instead of many smaller files
- Enhanced code maintainability by grouping related modules together
- Flexible creation of libraries with easy module listing, replacement, deletion and extraction

36.5 MPLAB Assembler, Linker and Librarian for Various Device Families

MPLAB Assembler produces relocatable machine code from symbolic assembly language for PIC24, PIC32 and dsPIC DSC devices. MPLAB XC Compiler uses the assembler to produce its object file. The assembler generates relocatable object files that can then be archived or linked with other relocatable object files and archives to create an executable file. Notable features of the assembler include:

- Support for the entire device instruction set
- Support for fixed-point and floating-point data
- Command-line interface
- Rich directive set
- Flexible macro language
- MPLAB X IDE compatibility

36.6 MPLAB X SIM Software Simulator

The MPLAB X SIM Software Simulator allows code development in a PC-hosted environment by simulating the PIC MCUs and dsPIC DSCs on an instruction level. On any given instruction, the data areas can be examined or modified and stimuli can be applied from a comprehensive stimulus controller. Registers can be logged to files for further run-time analysis. The trace buffer and logic analyzer display extend the power of the simulator to record and track program execution, actions on I/O, most peripherals and internal registers.

The MPLAB X SIM Software Simulator fully supports symbolic debugging using the MPLAB XC Compilers, and the MPASM and MPLAB Assemblers. The software simulator offers the flexibility to develop and debug code outside of the hardware laboratory environment, making it an excellent, economical software development tool.

36.7 MPLAB REAL ICE In-Circuit Emulator System

The MPLAB REAL ICE In-Circuit Emulator System is Microchip's next generation high-speed emulator for Microchip Flash DSC and MCU devices. It debugs and programs all 8, 16 and 32-bit MCU, and DSC devices with the easy-to-use, powerful graphical user interface of the MPLAB X IDE.

The emulator is connected to the design engineer's PC using a high-speed USB 2.0 interface and is connected to the target with either a connector compatible with in-circuit debugger systems (RJ-11) or with the new high-speed, noise tolerant, Low-Voltage Differential Signal (LVDS) interconnection (CAT5).

The emulator is field upgradable through future firmware downloads in MPLAB X IDE. MPLAB REAL ICE offers significant advantages over competitive emulators including full-speed emulation, run-time variable watches, trace analysis, complex breakpoints, logic probes, a ruggedized probe interface and long (up to three meters) interconnection cables.

36.8 MPLAB ICD 3 In-Circuit Debugger System

The MPLAB ICD 3 In-Circuit Debugger System is Microchip's most cost-effective, high-speed hardware debugger/programmer for Microchip Flash DSC and MCU devices. It debugs and programs PIC Flash microcontrollers and dsPIC DSCs with the powerful, yet easy-to-use graphical user interface of the MPLAB IDE.

The MPLAB ICD 3 In-Circuit Debugger probe is connected to the design engineer's PC using a high-speed USB 2.0 interface and is connected to the target with a connector compatible with the MPLAB ICD 2 or MPLAB REAL ICE systems (RJ-11). MPLAB ICD 3 supports all MPLAB ICD 2 headers.

36.9 PICkit 3 In-Circuit Debugger/Programmer

The MPLAB PICkit 3 allows debugging and programming of PIC and dsPIC Flash microcontrollers at a most affordable price point using the powerful graphical user interface of the MPLAB IDE. The MPLAB PICkit 3 is connected to the design engineer's PC using a full-speed USB interface and can be connected to the target via a Microchip debug (RJ-11) connector (compatible with MPLAB ICD 3 and MPLAB REAL ICE). The connector uses two device I/O pins and the Reset line to implement in-circuit debugging and In-Circuit Serial Programming™ (ICSP™).

36.10 MPLAB PM3 Device Programmer

The MPLAB PM3 Device Programmer is a universal, CE compliant device programmer with programmable voltage verification at VDDMIN and VDDMAX for maximum reliability. It features a large LCD display (128 x 64) for menus and error messages, and a modular, detachable socket assembly to support various package types. The ICSP cable assembly is included as a standard item. In Stand-Alone mode, the MPLAB PM3 Device Programmer can read, verify and program PIC devices without a PC connection. It can also set code protection in this mode. The MPLAB PM3 connects to the host PC via an RS-232 or USB cable. The MPLAB PM3 has high-speed communications and optimized algorithms for quick programming of large memory devices, and incorporates an MMC card for file storage and data applications.

36.11 Demonstration/Development Boards, Evaluation Kits, and Starter Kits

A wide variety of demonstration, development and evaluation boards for various PIC MCUs and dsPIC DSCs allows quick application development on fully functional systems. Most boards include prototyping areas for adding custom circuitry and provide application firmware and source code for examination and modification.

The boards support a variety of features, including LEDs, temperature sensors, switches, speakers, RS-232 interfaces, LCD displays, potentiometers and additional EEPROM memory.

The demonstration and development boards can be used in teaching environments, for prototyping custom circuits and for learning about various microcontroller applications.

In addition to the PICDEM™ and dsPICDEM™ demonstration/development board series of circuits, Microchip has a line of evaluation kits and demonstration software for analog filter design, KEELOQ® security ICs, CAN, IrDA®, PowerSmart battery management, SEEVAL® evaluation system, Sigma-Delta ADC, flow rate sensing, plus many more.

Also available are starter kits that contain everything needed to experience the specified device. This usually includes a single application and debug capability, all on one board.

Check the Microchip web page (www.microchip.com) for the complete list of demonstration, development and evaluation kits.

36.12 Third-Party Development Tools

Microchip also offers a great collection of tools from third-party vendors. These tools are carefully selected to offer good value and unique functionality.

- Device Programmers and Gang Programmers from companies, such as SoftLog and CCS
- Software Tools from companies, such as Gimpel and Trace Systems
- Protocol Analyzers from companies, such as Saleae and Total Phase
- Demonstration Boards from companies, such as MikroElektronika, Digilent® and Olimex
- Embedded Ethernet Solutions from companies, such as EZ Web Lynx, WIZnet and IPLogika®

PIC32MZ Embedded Connectivity with Floating Point Unit (EF) Family

37.0 ELECTRICAL CHARACTERISTICS

This section provides an overview of the PIC32MZ EF electrical characteristics. Additional information will be provided in future revisions of this document as it becomes available.

Absolute maximum ratings for the PIC32MZ EF devices are listed below. Exposure to these maximum rating conditions for extended periods may affect device reliability. Functional operation of the device at these or any other conditions, above the parameters indicated in the operation listings of this specification, is not implied.

Absolute Maximum Ratings

(See Note 1)

| | |
|---|---------------------------|
| Ambient temperature under bias | -40°C to +125°C |
| Storage temperature | -65°C to +150°C |
| Voltage on VDD with respect to VSS | -0.3V to +4.0V |
| Voltage on any pin that is not 5V tolerant, with respect to VSS (Note 3)..... | -0.3V to (VDD + 0.3V) |
| Voltage on any 5V tolerant pin with respect to VSS when VDD ≥ 2.1V (Note 3)..... | -0.3V to +5.5V |
| Voltage on any 5V tolerant pin with respect to VSS when VDD < 2.1V (Note 3)..... | -0.3V to +3.6V |
| Voltage on D+ or D- pin with respect to VUSB3V3 | -0.3V to (VUSB3V3 + 0.3V) |
| Voltage on VBUS with respect to VSS | -0.3V to +5.5V |
| Maximum current out of VSS pin(s) | 200 mA |
| Maximum current into VDD pin(s) (Note 2)..... | 200 mA |
| Maximum current sunk/sourced by any 4x I/O pin (Note 4)..... | 15 mA |
| Maximum current sunk/sourced by any 8x I/O pin (Note 4)..... | 25 mA |
| Maximum current sunk/sourced by any 12x I/O pin (Note 4)..... | 33 mA |
| Maximum current sunk by all ports | 150 mA |
| Maximum current sourced by all ports (Note 2)..... | 150 mA |

- Note 1:** Stresses above those listed under “**Absolute Maximum Ratings**” may cause permanent damage to the device. This is a stress rating only and functional operation of the device at those or any other conditions, above those indicated in the operation listings of this specification, is not implied. Exposure to maximum rating conditions for extended periods may affect device reliability.
- 2:** Maximum allowable current is a function of device maximum power dissipation (see [Table 37-2](#)).
- 3:** See the pin name tables ([Table 2](#) through [Table 4](#)) for the 5V tolerant pins.
- 4:** Characterized, but not tested. Refer to parameters [DO10](#), [DO20](#), and [DO20a](#) for the 4x, 8x, and 12x I/O pin lists.

PIC32MZ Embedded Connectivity with Floating Point Unit (EF) Family

37.1 DC Characteristics

TABLE 37-1: OPERATING MIPS VS. VOLTAGE

| Characteristic | VDD Range (in Volts) (Note 1) | Temp. Range (in °C) | Max. Frequency | Comment |
|----------------|-------------------------------------|------------------------|--------------------|---------|
| | | | PIC32MZ EF Devices | |
| DC5 | 2.1V-3.6V | -40°C to +85°C | 200 MHz | — |
| DC5b | 2.1V-3.6V | -40°C to +125°C | 180 MHz | Planned |

Note 1: Overall functional device operation at $V_{BORMIN} < V_{DD} < V_{DDMIN}$ is guaranteed, but not characterized. All device Analog modules, such as ADC, etc., will function, but with degraded performance below V_{DDMIN} . Refer to parameter BO10 in [Table 37-5](#) for BOR values.

TABLE 37-2: THERMAL OPERATING CONDITIONS

| Rating | Symbol | Min. | Typical | Max. | Unit |
|--|--------|-----------------------------|---------|------|------|
| Industrial Temperature Devices | | | | | |
| Operating Junction Temperature Range | TJ | -40 | — | +125 | °C |
| Operating Ambient Temperature Range | TA | -40 | — | +85 | °C |
| Extended Temperature Devices | | | | | |
| Operating Junction Temperature Range | TJ | -40 | — | +140 | °C |
| Operating Ambient Temperature Range | TA | -40 | — | +125 | °C |
| Power Dissipation: Internal Chip Power Dissipation: $P_{INT} = V_{DD} \times (I_{DD} - S_{IOH})$ I/O Pin Power Dissipation: $P_{I/O} = S \left((V_{DD} - V_{OH}) \times I_{OH} \right) + S \left(V_{OL} \times I_{OL} \right)$ | PD | PINT + PI/O | | | W |
| Maximum Allowed Power Dissipation | PDMAX | $(T_J - T_A) / \theta_{JA}$ | | | W |

TABLE 37-3: THERMAL PACKAGING CHARACTERISTICS

| Characteristics | Symbol | Typical | Max. | Unit | Notes |
|---|---------------|---------|------|------|-------|
| Package Thermal Resistance, 64-pin QFN (9x9x0.9 mm) | θ_{JA} | 28 | — | °C/W | 1 |
| Package Thermal Resistance, 64-pin TQFP (10x10x1 mm) | θ_{JA} | 49 | — | °C/W | 1 |
| Package Thermal Resistance, 100-pin TQFP (12x12x1 mm) | θ_{JA} | 43 | — | °C/W | 1 |
| Package Thermal Resistance, 100-pin TQFP (14x14x1 mm) | θ_{JA} | 40 | — | °C/W | 1 |
| Package Thermal Resistance, 124-pin VTLA (9x9x0.9 mm) | θ_{JA} | 30 | — | °C/W | 1 |
| Package Thermal Resistance, 144-pin TQFP (16x16x1 mm) | θ_{JA} | 42 | — | °C/W | 1 |
| Package Thermal Resistance, 144-pin LQFP (20x20x1.4 mm) | θ_{JA} | 39 | — | °C/W | 1 |

Note 1: Junction to ambient thermal resistance, Theta-JA (θ_{JA}) numbers are achieved by package simulations.

PIC32MZ Embedded Connectivity with Floating Point Unit (EF) Family

TABLE 37-4: DC TEMPERATURE AND VOLTAGE SPECIFICATIONS

| DC CHARACTERISTICS | | | Standard Operating Conditions: 2.1V to 3.6V (unless otherwise stated) Operating temperature $-40^{\circ}\text{C} \leq T_A \leq +85^{\circ}\text{C}$ for Industrial $-40^{\circ}\text{C} \leq T_A \leq +125^{\circ}\text{C}$ for Extended | | | | |
|--------------------------|--------|---|---|---------|------|------------------|----------------------------------|
| Param. No. | Symbol | Characteristics | Min. | Typical | Max. | Units | Conditions |
| Operating Voltage | | | | | | | |
| DC10 | VDD | Supply Voltage (Note 1) | 2.1 | — | 3.6 | V | — |
| DC12 | VDR | RAM Data Retention Voltage (Note 2) | 2.0 | — | — | V | — |
| DC16 | VPOR | VDD Start Voltage to Ensure Internal Power-on Reset Signal (Note 3) | 1.75 | — | — | V | — |
| DC17 | SVDD | VDD Rise Rate to Ensure Internal Power-on Reset Signal | 0.000011 | — | 1.1 | V/ μs | 300 ms to 3 μs @ 3.3V |

Note 1: Overall functional device operation at $V_{BORMIN} < V_{DD} < V_{DDMIN}$ is guaranteed, but not characterized. All device Analog modules, such as ADC, etc., will function, but with degraded performance below V_{DDMIN} . Refer to parameter BO10 in [Table 37-5](#) for BOR values.

2: This is the limit to which V_{DD} can be lowered without losing RAM data.

3: This is the limit to which V_{DD} must be lowered to ensure Power-on Reset.

TABLE 37-5: ELECTRICAL CHARACTERISTICS: BOR

| DC CHARACTERISTICS | | | Standard Operating Conditions: 2.1V to 3.6V (unless otherwise stated) Operating temperature $-40^{\circ}\text{C} \leq T_A \leq +85^{\circ}\text{C}$ for Industrial $-40^{\circ}\text{C} \leq T_A \leq +125^{\circ}\text{C}$ for Extended | | | | |
|--------------------|--------|---|---|---------|------|-------|------------|
| Param. No. | Symbol | Characteristics | Min. ⁽¹⁾ | Typical | Max. | Units | Conditions |
| BO10 | VBOR | BOR Event on V_{DD} transition high-to-low (Note 2) | 1.88 | — | 2.02 | V | — |

Note 1: Parameters are for design guidance only and are not tested in manufacturing.

2: Overall functional device operation at $V_{BORMIN} < V_{DD} < V_{DDMIN}$ is tested, but not characterized. All device Analog modules, such as ADC, etc., will function, but with degraded performance below V_{DDMIN} .

PIC32MZ Embedded Connectivity with Floating Point Unit (EF) Family

TABLE 37-6: DC CHARACTERISTICS: OPERATING CURRENT (IDD)

| DC CHARACTERISTICS | | | Standard Operating Conditions: 2.1V to 3.6V (unless otherwise stated) Operating temperature -40°C ≤ TA ≤ +85°C for Industrial -40°C ≤ TA ≤ +125°C for Extended | |
|--|------------------------|------------------------|---|--------------------|
| Parameter No. | Typical ⁽³⁾ | Maximum ⁽⁶⁾ | Units | Conditions |
| Operating Current (IDD)⁽¹⁾ | | | | |
| DC20 | 8 | 25 | mA | 4 MHz (Note 4,5) |
| DC21 | 10 | 30 | mA | 10 MHz (Note 5) |
| DC22 | 32 | 65 | mA | 60 MHz (Note 2,4) |
| DC23 | 40 | 75 | mA | 80 MHz (Note 2,4) |
| DC25 | 61 | 95 | mA | 130 MHz (Note 2,4) |
| DC26 | 72 | 110 | mA | 160 MHz (Note 2,4) |
| DC28 | 81 | 120 | mA | 180 MHz (Note 2,4) |
| DC27a | 92 | 130 | mA | 200 MHz (Note 2) |
| DC27b | 78 | 100 | mA | 200 MHz (Note 4,5) |

- Note 1:** A device's IDD supply current is mainly a function of the operating voltage and frequency. Other factors, such as PBCLK (Peripheral Bus Clock) frequency, number of peripheral modules enabled, internal code execution pattern, I/O pin loading and switching rate, oscillator type, as well as temperature, can have an impact on the current consumption.
- 2:** The test conditions for IDD measurements are as follows:
- Oscillator mode is EC (for 8 MHz and below) and EC+PLL (for above 8 MHz) with OSC1 driven by external square wave from rail-to-rail, (OSC1 input clock input over/undershoot < 100 mV required)
 - OSC2/CLKO is configured as an I/O input pin
 - USB PLL is disabled (USBMD = 1), VUSB3V3 is connected to VSS
 - CPU, Program Flash, and SRAM data memory are operational, Program Flash memory Wait states are equal to two
 - L1 Cache and Prefetch modules are enabled
 - No peripheral modules are operating, (ON bit = 0), and the associated PMD bit is set. All clocks are disabled ON bit (PBxDIV<15>) = 0 (x ≠ 1,7)
 - WDT, DMT, Clock Switching, Fail-Safe Clock Monitor, and Secondary Oscillator are disabled
 - All I/O pins are configured as inputs and pulled to VSS
 - MCLR = VDD
 - CPU executing `while(1)` statement from Flash
 - RTCC and JTAG are disabled
- 3:** Data in "Typical" column is at 3.3V, +25°C at specified operating frequency unless otherwise stated. Parameters are for design guidance only and are not tested.
- 4:** This parameter is characterized, but not tested in manufacturing.
- 5:** Note 2 applies with the following exceptions: L1 Cache and Prefetch modules are disabled, Program Flash memory Wait states are equal to seven.
- 6:** Data in the "Maximum" column is at 3.3V, +85°C at specified operating frequency, unless otherwise stated. Parameters are for design guidance only and are not tested.

PIC32MZ Embedded Connectivity with Floating Point Unit (EF) Family

TABLE 37-7: DC CHARACTERISTICS: IDLE CURRENT (IDLE)

| DC CHARACTERISTICS | | | Standard Operating Conditions: 2.1V to 3.6V (unless otherwise stated) Operating temperature -40°C ≤ TA ≤ +85°C for Industrial -40°C ≤ TA ≤ +125°C for Extended | |
|--|------------------------|------------------------|---|------------------|
| Parameter No. | Typical ⁽²⁾ | Maximum ⁽⁴⁾ | Units | Conditions |
| Idle Current (IDLE): Core Off, Clock on Base Current (Note 1) | | | | |
| DC30a | 7 | 22 | mA | 4 MHz (Note 3) |
| DC31a | 8 | 24 | mA | 10 MHz |
| DC32a | 13 | 32 | mA | 60 MHz (Note 3) |
| DC33a | 21 | 42 | mA | 130 MHz (Note 3) |
| DC34 | 26 | 48 | mA | 180 MHz (Note 3) |
| DC35 | 28 | 52 | mA | 200 MHz |

Note 1: The test conditions for IDLE current measurements are as follows:

- Oscillator mode is EC (for 8 MHz and below) and EC+PLL (for above 8 MHz) with OSC1 driven by external square wave from rail-to-rail, (OSC1 input clock input over/undershoot < 100 mV required)
 - OSC2/CLKO is configured as an I/O input pin
 - USB PLL is disabled (USBPMD = 1), VUSB3V3 is connected to VSS, PBCLKx divisor = 1:128 ('x' ≠ 7)
 - CPU is in Idle mode (CPU core Halted)
 - L1 Cache and Prefetch modules are disabled
 - No peripheral modules are operating, (ON bit = 0), but the associated PMD bit is cleared (except USBPMD)
 - WDT, DMT, Clock Switching, Fail-Safe Clock Monitor, and Secondary Oscillator are disabled
 - All I/O pins are configured as inputs and pulled to VSS
 - $\overline{\text{MCLR}} = \text{VDD}$
 - RTCC and JTAG are disabled
- 2:** Data in "Typical" column is at 3.3V, +25°C unless otherwise stated. Parameters are for design guidance only and are not tested.
- 3:** This parameter is characterized, but not tested in manufacturing.
- 4:** Data in the "Maximum" column is at 3.3V, +85°C at specified operating frequency, unless otherwise stated. Parameters are for design guidance only and are not tested.

PIC32MZ Embedded Connectivity with Floating Point Unit (EF) Family

TABLE 37-8: DC CHARACTERISTICS: POWER-DOWN CURRENT (IPD)

| DC CHARACTERISTICS | | Standard Operating Conditions: 2.1V to 3.6V (unless otherwise stated) Operating temperature -40°C ≤ TA ≤ +85°C for Industrial -40°C ≤ TA ≤ +125°C for Extended | | |
|--|------------------------|--|-------|--|
| Param. No. | Typical ⁽²⁾ | Maximum ⁽⁵⁾ | Units | Conditions |
| Power-Down Current (IPD) (Note 1) | | | | |
| DC40k | 0.7 | 7 | mA | -40°C |
| DC40l | 1.5 | 7 | mA | +25°C |
| DC40n | 7 | 20 | mA | +85°C |
| DC40m | 20 | — | mA | +125°C |
| Base Power-Down Current | | | | |
| Module Differential Current | | | | |
| DC41e | 15 | 50 | μA | 3.6V Watchdog Timer Current: ΔI _{WDT} (Note 3) |
| DC42e | 25 | 50 | μA | 3.6V RTCC + Timer1 w/32 kHz Crystal: ΔI _{RTCC} (Note 3) |
| DC43d | 3 | 3.8 | mA | 3.6V ADC: ΔI _{ADC} (Notes 3, 4) |
| DC44 | 15 | 50 | μA | 3.6V Deadman Timer Current: ΔI _{DMT} (Note 3) |

Note 1: The test conditions for IPD current measurements are as follows:

- Oscillator mode is EC (for 8 MHz and below) and EC+PLL (for above 8 MHz) with OSC1 driven by external square wave from rail-to-rail, (OSC1 input clock input over/undershoot < 100 mV required)
 - OSC2/CLKO is configured as an I/O input pin
 - USB PLL is disabled (USBMD = 1), V_{USB3V3} is connected to V_{SS}
 - CPU is in Sleep mode
 - L1 Cache and Prefetch modules are disabled
 - No peripheral modules are operating, (ON bit = 0), and the associated PMD bit is set. All clocks are disabled ON bit (PBxDIV<15>) = 0 (x ≠ 1,7)
 - WDT, DMT, Clock Switching, Fail-Safe Clock Monitor, and Secondary Oscillator are disabled
 - All I/O pins are configured as inputs and pulled to V_{SS}
 - MCLR = V_{DD}
 - RTCC and JTAG are disabled
 - Voltage regulator is in Stand-by mode (VREGS = 0)
- 2:** Data in the “Typical” column is at 3.3V, +25°C unless otherwise stated. Parameters are for design guidance only and are not tested.
- 3:** The Δ current is the additional current consumed when the module is enabled. This current should be added to the base IPD current.
- 4:** Voltage regulator is operational (VREGS = 1).
- 5:** Data in the “Maximum” column is at 3.3V, +85°C at specified operating frequency, unless otherwise stated. Parameters are for design guidance only and are not tested.

PIC32MZ Embedded Connectivity with Floating Point Unit (EF) Family

TABLE 37-9: DC CHARACTERISTICS: I/O PIN INPUT SPECIFICATIONS

| DC CHARACTERISTICS | | | Standard Operating Conditions: 2.1V to 3.6V (unless otherwise stated) | | | | |
|---|------------|--|---|---------------------|---|-------|---|
| | | | Operating temperature -40°C ≤ TA ≤ +85°C for Industrial -40°C ≤ TA ≤ +125°C for Extended | | | | |
| Param. No. | Symbol | Characteristics | Min. | Typ. ⁽¹⁾ | Max. | Units | Conditions |
| DI10 DI18 DI19 | VIL | Input Low Voltage | | | | | |
| | | I/O Pins with PMP | VSS | — | 0.15 * VDD | V | SMBus disabled (Note 4) |
| | | I/O Pins | VSS | — | 0.2 * VDD | V | |
| | | SDAx, SCLx | VSS | — | 0.3 * VDD | V | |
| SDAx, SCLx | VSS | — | 0.8 | V | SMBus enabled (Note 4) | | |
| DI20 DI28a DI29a DI28b DI29b | VIH | Input High Voltage | | | | | |
| | | I/O Pins not 5V-tolerant ⁽⁵⁾ | 0.80 * VDD | — | VDD | V | (Note 4,6) |
| | | I/O Pins 5V-tolerant with PMP ⁽⁵⁾ | 0.80 * VDD | — | 5.5 | V | (Note 4,6) |
| | | I/O Pins 5V-tolerant ⁽⁵⁾ | 0.80 * VDD | — | 5.5 | V | SMBus disabled (Note 4,6) |
| | | SDAx, SCLx on non-5V tolerant pins ⁽⁵⁾ | 0.80 * VDD | — | VDD | V | |
| | | SDAx, SCLx on non-5V tolerant pins ⁽⁵⁾ | 2.1 | — | VDD | V | SMBus enabled, 2.1V ≤ VPIN ≤ 5.5 (Note 4,6) |
| SDAx, SCLx on 5V tolerant pins ⁽⁵⁾ | 0.80 * VDD | — | 5.5 | V | SMBus disabled (Note 4,6) | | |
| SDAx, SCLx on 5V tolerant pins ⁽⁵⁾ | 2.1 | — | 5.5 | V | SMBus enabled, 2.1V ≤ VPIN ≤ 5.5 (Note 4,6) | | |
| DI30 | ICNPU | Change Notification Pull-up Current | — | — | -40 | µA | VDD = 3.3V, VPIN = VSS (Note 3,6) |
| DI31 | ICNPD | Change Notification Pull-down Current⁽⁴⁾ | 40 | — | — | µA | VDD = 3.3V, VPIN = VDD |
| DI50 DI51 DI55 DI56 | IIL | Input Leakage Current (Note 3) | | | | | |
| | | I/O Ports | — | — | ±1 | µA | VSS ≤ VPIN ≤ VDD, Pin at high-impedance |
| | | Analog Input Pins | — | — | ±1 | µA | VSS ≤ VPIN ≤ VDD, Pin at high-impedance |
| | | $\overline{\text{MCLR}}^{(2)}$ | — | — | ±1 | µA | VSS ≤ VPIN ≤ VDD |
| | | OSC1 | — | — | ±1 | µA | VSS ≤ VPIN ≤ VDD, HS mode |

Note 1: Data in “Typical” column is at 3.3V, +25°C unless otherwise stated. Parameters are for design guidance only and are not tested.

- 2:** The leakage current on the $\overline{\text{MCLR}}$ pin is strongly dependent on the applied voltage level. The specified levels represent normal operating conditions. Higher leakage current may be measured at different input voltages.
- 3:** Negative current is defined as current sourced by the pin.
- 4:** This parameter is characterized, but not tested in manufacturing.
- 5:** See the pin name tables (Table 2 through Table 4) for the 5V-tolerant pins.
- 6:** The VIH specifications are only in relation to externally applied inputs, and not with respect to the user-selectable internal pull-ups. External open drain input signals utilizing the internal pull-ups of the PIC32 device are guaranteed to be recognized only as a logic “high” internally to the PIC32 device, provided that the external load does not exceed the minimum value of ICNPU. For External “input” logic inputs that require a pull-up source, to guarantee the minimum VIH of those components, it is recommended to use an external pull-up resistor rather than the internal pull-ups of the PIC32 device.

PIC32MZ Embedded Connectivity with Floating Point Unit (EF) Family

TABLE 37-10: DC CHARACTERISTICS: I/O PIN INPUT INJECTION CURRENT SPECIFICATIONS

| DC CHARACTERISTICS | | | Standard Operating Conditions: 2.1V to 3.6V (unless otherwise stated) Operating temperature -40°C ≤ TA ≤ +85°C for Industrial -40°C ≤ TA ≤ +125°C for Extended | | | | |
|--------------------|--------|--|--|------------------------|-----------------------|-------|---|
| Param. No. | Symbol | Characteristics | Min. | Typical ⁽¹⁾ | Max. | Units | Conditions |
| DI60a | IICL | Input Low Injection Current | 0 | — | -5 ^(2,5) | mA | This parameter applies to all pins, with the exception of RB10. Maximum IICH current for this exception is 0 mA. |
| DI60b | IICH | Input High Injection Current | 0 | — | +5 ^(3,4,5) | mA | This parameter applies to all pins, with the exception of all 5V tolerant pins, OSC1, OSC0, SOSCI, SOSCO, D+, D- and RB10. Maximum IICH current for these exceptions is 0 mA. |
| DI60c | ΣIICT | Total Input Injection Current (sum of all I/O and control pins) | -20 ⁽⁶⁾ | — | +20 ⁽⁶⁾ | mA | Absolute instantaneous sum of all ± input injection currents from all I/O pins (IICL + IICH) ≤ ΣIICT |

Note 1: Data in “Typical” column is at 3.3V, +25°C unless otherwise stated. Parameters are for design guidance only and are not tested.

2: VIL source < (VSS - 0.3). Characterized but not tested.

3: VIH source > (VDD + 0.3) for non-5V tolerant pins only.

4: Digital 5V tolerant pins do not have an internal high side diode to VDD, and therefore, cannot tolerate any “positive” input injection current.

5: Injection currents > | 0 | can affect the ADC results by approximately 4 to 6 counts (i.e., VIH Source > (VDD + 0.3) or VIL source < (VSS - 0.3)).

6: Any number and/or combination of I/O pins not excluded under IICL or IICH conditions are permitted provided the “absolute instantaneous” sum of the input injection currents from all pins do not exceed the specified limit. If **Note 2**, IICL = ((VSS - 0.3) - VIL source) / RS. If **Note 3**, IICH = ((IICH source - (VDD + 0.3)) / RS). RS = Resistance between input source voltage and device pin. If (VSS - 0.3) ≤ VSOURCE ≤ (VDD + 0.3), injection current = 0.

PIC32MZ Embedded Connectivity with Floating Point Unit (EF) Family

TABLE 37-11: DC CHARACTERISTICS: I/O PIN OUTPUT SPECIFICATIONS

| DC CHARACTERISTICS | | | Standard Operating Conditions: 2.1V to 3.6V (unless otherwise stated) Operating temperature $-40^{\circ}\text{C} \leq T_A \leq +85^{\circ}\text{C}$ for Industrial $-40^{\circ}\text{C} \leq T_A \leq +125^{\circ}\text{C}$ for Extended | | | | |
|--------------------|------|--|---|------|------|-------|--|
| Param. | Sym. | Characteristic | Min. | Typ. | Max. | Units | Conditions ⁽¹⁾ |
| DO10 | VOL | Output Low Voltage I/O Pins 4x Sink Driver Pins - RA3, RA9, RA10, RA14, RA15 RB0-RB2, RB4, RB6, RB7, RB11, RB13 RC12-RC15 RD0, RD6-RD7, RD11, RD14 RE8, RE9 RF2, RF3, RF8 RG15 RH0, RH1, RH4-RH6, RH8-RH13 RJ0-RJ2, RJ8, RJ9, RJ11 | — | — | 0.4 | V | $I_{OL} \leq 10 \text{ mA}$, $V_{DD} = 3.3\text{V}$ |
| | | Output Low Voltage I/O Pins: 8x Sink Driver Pins - RA0-RA2, RA4, RA5 RB3, RB5, RB8-RB10, RB12, RB14, RB15 RC1-RC4 RD1-RD5, RD9, RD10, RD12, RD13, RD15 RE4-RE7 RF0, RF4, RF5, RF12, RF13 RG0, RG1, RG6-RG9 RH2, RH3, RH7, RH14, RH15 RJ3-RJ7, RJ10, RJ12-RJ15 RK0-RK7 | — | — | 0.4 | V | $I_{OL} \leq 15 \text{ mA}$, $V_{DD} = 3.3\text{V}$ |
| | | Output Low Voltage I/O Pins: 12x Sink Driver Pins - RA6, RA7 RE0-RE3 RF1 RG12-RG14 | — | — | 0.4 | V | $I_{OL} \leq 20 \text{ mA}$, $V_{DD} = 3.3\text{V}$ |

Note 1: Parameters are characterized, but not tested.

PIC32MZ Embedded Connectivity with Floating Point Unit (EF) Family

TABLE 37-11: DC CHARACTERISTICS: I/O PIN OUTPUT SPECIFICATIONS (CONTINUED)

| DC CHARACTERISTICS | | | Standard Operating Conditions: 2.1V to 3.6V (unless otherwise stated) Operating temperature $-40^{\circ}\text{C} \leq T_A \leq +85^{\circ}\text{C}$ for Industrial $-40^{\circ}\text{C} \leq T_A \leq +125^{\circ}\text{C}$ for Extended | | | | |
|--------------------|------|---|---|------|------|-------|---|
| Param. | Sym. | Characteristic | Min. | Typ. | Max. | Units | Conditions ⁽¹⁾ |
| DO20 | VOH | Output High Voltage I/O Pins: 4x Source Driver Pins - RA3, RA9, RA10, RA14, RA15 RB0-RB2, RB4, RB6-RB7, RB11, RB13 RC12-RC15 RD0, RD6-RD7, RD11, RD14 RE8, RE9 RF2, RF3, RF8 RG15 RH0, RH1, RH4-RH6, RH8-RH13 RJ0-RJ2, RJ8, RJ9, RJ11 | 2.4 | — | — | V | $I_{OH} \geq -10 \text{ mA}$, $V_{DD} = 3.3\text{V}$ |
| | | Output High Voltage I/O Pins: 8x Source Driver Pins - RA0-RA2, RA4, RA5 RB3, RB5, RB8-RB10, RB12, RB14, RB15 RC1-RC4 RD1-RD5, RD9, RD10, RD12, RD13, RD15 RE4-RE7 RF0, RF4, RF5, RF12, RF13 RG0, RG1, RG6-RG9 RH2, RH3, RH7, RH14, RH15 RJ3-RJ7, RJ10, RJ12-RJ15 RK0-RK7 | 2.4 | — | — | V | $I_{OH} \geq -15 \text{ mA}$, $V_{DD} = 3.3\text{V}$ |
| | | Output High Voltage I/O Pins: 12x Source Driver Pins - RA6, RA7 RE0-RE3 RF1 RG12-RG14 | 2.4 | — | — | V | $I_{OH} \geq -20 \text{ mA}$, $V_{DD} = 3.3\text{V}$ |

Note 1: Parameters are characterized, but not tested.

PIC32MZ Embedded Connectivity with Floating Point Unit (EF) Family

TABLE 37-11: DC CHARACTERISTICS: I/O PIN OUTPUT SPECIFICATIONS (CONTINUED)

| DC CHARACTERISTICS | | | Standard Operating Conditions: 2.1V to 3.6V (unless otherwise stated) Operating temperature $-40^{\circ}\text{C} \leq T_A \leq +85^{\circ}\text{C}$ for Industrial $-40^{\circ}\text{C} \leq T_A \leq +125^{\circ}\text{C}$ for Extended | | | | |
|--------------------|------|---|---|------|------|-------|---|
| Param. | Sym. | Characteristic | Min. | Typ. | Max. | Units | Conditions ⁽¹⁾ |
| DO20a | VOH1 | Output High Voltage I/O Pins: 4x Source Driver Pins - RA3, RA9, RA10, RA14, RA15 RB0-RB2, RB4, RB6-RB7, RB11, RB13 RC12-RC15 RD0, RD6-RD7, RD11, RD14 RE8, RE9 RF2, RF3, RF8 RG15 RH0, RH1, RH4-RH6, RH8-RH13 RJ0-RJ2, RJ8, RJ9, RJ11 | 1.5 | — | — | V | $I_{OH} \geq -14 \text{ mA}$, $V_{DD} = 3.3\text{V}$ |
| | | | 2.0 | — | — | V | $I_{OH} \geq -12 \text{ mA}$, $V_{DD} = 3.3\text{V}$ |
| | | | 3.0 | — | — | V | $I_{OH} \geq -7 \text{ mA}$, $V_{DD} = 3.3\text{V}$ |
| | | Output High Voltage I/O Pins: 8x Source Driver Pins - RA0-RA2, RA4, RA5 RB3, RB5, RB8-RB10, RB12, RB14, RB15 RC1-RC4 RD1-RD5, RD9, RD10, RD12, RD13, RD15 RE4-RE7 RF0, RF4, RF5, RF12, RF13 RG0, RG1, RG6-RG9 RH2, RH3, RH7, RH14, RH15 RJ3-RJ7, RJ10, RJ12-RJ15 RK0-RK7 | 1.5 | — | — | V | $I_{OH} \geq -22 \text{ mA}$, $V_{DD} = 3.3\text{V}$ |
| | | | 2.0 | — | — | V | $I_{OH} \geq -18 \text{ mA}$, $V_{DD} = 3.3\text{V}$ |
| | | | 3.0 | — | — | V | $I_{OH} \geq -10 \text{ mA}$, $V_{DD} = 3.3\text{V}$ |
| | | Output High Voltage I/O Pins: 12x Source Driver Pins - RA6, RA7 RE0-RE3 RF1 RG12-RG14 | 1.5 | — | — | V | $I_{OH} \geq -32 \text{ mA}$, $V_{DD} = 3.3\text{V}$ |
| | | | 2.0 | — | — | V | $I_{OH} \geq -25 \text{ mA}$, $V_{DD} = 3.3\text{V}$ |
| | | | 3.0 | — | — | V | $I_{OH} \geq -14 \text{ mA}$, $V_{DD} = 3.3\text{V}$ |

Note 1: Parameters are characterized, but not tested.

PIC32MZ Embedded Connectivity with Floating Point Unit (EF) Family

TABLE 37-12: DC CHARACTERISTICS: PROGRAM MEMORY⁽³⁾

| DC CHARACTERISTICS | | | Standard Operating Conditions: 2.1V to 3.6V (unless otherwise stated) Operating temperature -40°C ≤ TA ≤ +85°C for Industrial -40°C ≤ TA ≤ +125°C for Extended | | | | |
|--------------------|-------|---|---|---------------------|--------|------------|-------------|
| Param. No. | Sym. | Characteristics | Min. | Typ. ⁽¹⁾ | Max. | Units | Conditions |
| D130a | EP | Cell Endurance | 10,000 | — | — | E/W | Without ECC |
| D130b | | | 20,000 | — | — | E/W | With ECC |
| D131 | VPR | VDD for Read | VDDMIN | — | VDDMAX | V | — |
| D132 | VPEW | VDD for Erase or Write | VDDMIN | — | VDDMAX | V | — |
| D134a | TRETD | Characteristic Retention | 10 | — | — | Year | Without ECC |
| D134b | | | 20 | — | — | Year | With ECC |
| D135 | IDDP | Supply Current during Programming | — | — | 30 | mA | — |
| D136 | TRW | Row Write Cycle Time (Notes 2, 4) | — | 66813 | — | FRC Cycles | — |
| D137 | TQWW | Quad Word Write Cycle Time (Note 4) | — | 773 | — | FRC Cycles | — |
| D138 | TWW | Word Write Cycle Time (Note 4) | — | 383 | — | FRC Cycles | — |
| D139 | TCE | Chip Erase Cycle Time (Note 4) | — | 515373 | — | FRC Cycles | — |
| D140 | TPFE | All Program Flash (Upper and Lower regions) Erase Cycle Time (Note 4) | — | 256909 | — | FRC Cycles | — |
| D141 | TPBE | Program Flash (Upper or Lower regions) Erase Cycle Time (Note 4) | — | 128453 | — | FRC Cycles | — |
| D142 | TPGE | Page Erase Cycle Time (Note 4) | — | 128453 | — | FRC Cycles | — |

- Note 1:** Data in “Typical” column is at 3.3V, +25°C unless otherwise stated.
Note 2: The minimum PBCLK5 for row programming is 4 MHz.
Note 3: Refer to the “PIC32 Flash Programming Specification” (DS60001145) for operating conditions during programming and erase cycles.
Note 4: This parameter depends on FRC accuracy (see Table 37-20) and FRC tuning values (see the OSCTUN register: Register 8-2).

TABLE 37-13: DC CHARACTERISTICS: PROGRAM FLASH MEMORY WAIT STATES

| DC CHARACTERISTICS | | Standard Operating Conditions: 2.1V to 3.6V (unless otherwise stated) Operating temperature -40°C ≤ TA ≤ +85°C for Industrial -40°C ≤ TA ≤ +125°C for Extended | | |
|---|--------------------|---|------------|--|
| Required Flash Wait States ⁽¹⁾ | SYSClk | Units | Conditions | |
| With ECC: | | | | |
| 0 Wait states | 0 < SYSClk ≤ 66 | MHz | — | |
| 1 Wait state | 66 < SYSClk ≤ 133 | | | |
| 2 Wait states | 133 < SYSClk ≤ 200 | | | |
| Without ECC: | | | | |
| 0 Wait states | 0 < SYSClk ≤ 83 | MHz | — | |
| 1 Wait state | 83 < SYSClk ≤ 166 | | | |
| 2 Wait states | 166 < SYSClk ≤ 200 | | | |

- Note 1:** To use Wait states, the Prefetch module must be enabled (PREFEN<1:0> ≠ 00) and the PFMWS<2:0> bits must be written with the desired Wait state value.

PIC32MZ Embedded Connectivity with Floating Point Unit (EF) Family

TABLE 37-14: COMPARATOR SPECIFICATIONS

| DC CHARACTERISTICS | | | Standard Operating Conditions (see Note 3): 2.1V to 3.6V (unless otherwise stated) Operating temperature -40°C ≤ TA ≤ +85°C for Industrial -40°C ≤ TA ≤ +125°C for Extended | | | | |
|--------------------|--------|------------------------------------|---|---------|-------|-------|---|
| Param. No. | Symbol | Characteristics | Min. | Typical | Max. | Units | Comments |
| D300 | VIOFF | Input Offset Voltage | — | ±10 | — | mV | AVDD = VDD, AVSS = VSS |
| D301 | VICM | Input Common Mode Voltage | 0 | — | VDD | V | AVDD = VDD, AVSS = VSS (Note 2) |
| D302 | CMRR | Common Mode Rejection Ratio | 55 | — | — | dB | Max VICM = (VDD – 1)V (Note 2, 4) |
| D303 | TRESP | Response Time | — | 150 | — | ns | AVDD = VDD, AVSS = VSS (Notes 1, 2) |
| D304 | ON2OV | Comparator Enabled to Output Valid | — | — | 10 | µs | Comparator module is configured before setting the comparator ON bit (Note 2) |
| D305 | IVREF | Internal Voltage Reference | 1.194 | 1.2 | 1.206 | V | — |

- Note 1:** Response time measured with one comparator input at (VDD – 1.5)/2, while the other input transitions from VSS to VDD.
- 2:** These parameters are characterized but not tested.
- 3:** The Comparator module is functional at VBORMIN < VDD < VDDMIN, but with degraded performance. Unless otherwise stated, module functionality is guaranteed, but not characterized.
- 4:** CMRR measurement characterized with a 1 MΩ resistor in parallel with a 25 pF capacitor to VSS.

TABLE 37-15: COMPARATOR VOLTAGE REFERENCE SPECIFICATIONS

| DC CHARACTERISTICS | | | Standard Operating Conditions (see Note 3): 2.1V to 3.6V (unless otherwise stated) Operating temperature -40°C ≤ TA ≤ +85°C for Industrial -40°C ≤ TA ≤ +125°C for Extended | | | | |
|--------------------|---------|---|---|------|-----------------|-------|---|
| Param. No. | Symbol | Characteristics | Min. | Typ. | Max. | Units | Comments |
| D312 | TSET | Internal 4-bit DAC Comparator Reference Settling time | — | — | 10 | µs | See Note 1 |
| D313 | DACREFH | CVREF Input Voltage Reference Range | AVSS | — | AVDD | V | CVRSRC with CVRSS = 0 |
| | | | VREF- | — | VREF+ | V | CVRSRC with CVRSS = 1 |
| D314 | DVREF | CVREF Programmable Output Range | 0 | — | 0.625 x DACREFH | V | 0 to 0.625 DACREFH with DACREFH/24 step size |
| | | | 0.25 x DACREFH | — | 0.719 x DACREFH | V | 0.25 x DACREFH to 0.719 DACREFH with DACREFH/32 step size |
| D315 | DACRES | Resolution | — | — | DACREFH/24 | | CVRCON<CVRR> = 1 |
| | | | — | — | DACREFH/32 | | CVRCON<CVRR> = 0 |
| D316 | DACACC | Absolute Accuracy ⁽²⁾ | — | — | 1/4 | LSB | DACREFH/24, CVRCON<CVRR> = 1 |
| | | | — | — | 1/2 | LSB | DACREFH/32, CVRCON<CVRR> = 0 |

- Note 1:** Settling time was measured while CVRR = 1 and CVR<3:0> transitions from '0000' to '1111'. This parameter is characterized, but is not tested in manufacturing.
- 2:** These parameters are characterized but not tested.

PIC32MZ Embedded Connectivity with Floating Point Unit (EF) Family

37.2 AC Characteristics and Timing Parameters

The information contained in this section defines PIC32MZ EF device AC characteristics and timing parameters.

FIGURE 37-1: LOAD CONDITIONS FOR DEVICE TIMING SPECIFICATIONS

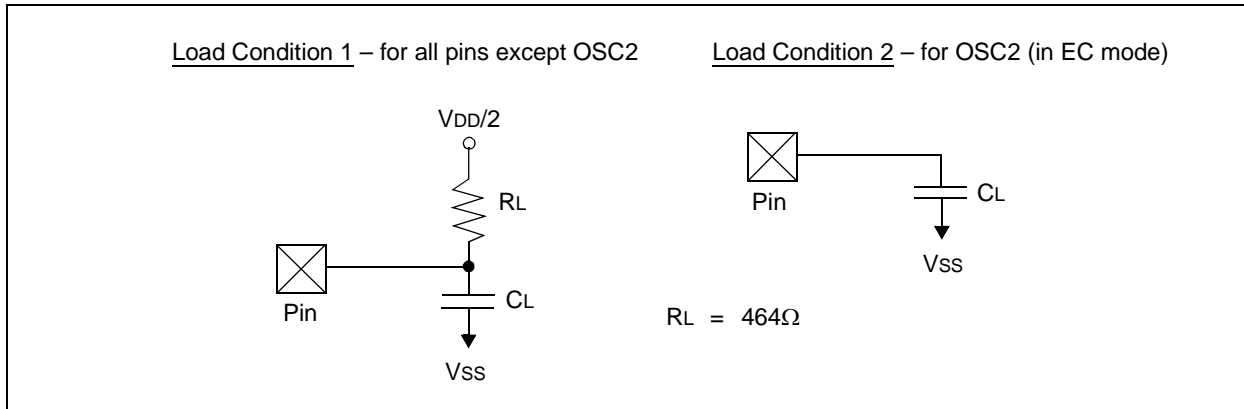

TABLE 37-16: CAPACITIVE LOADING REQUIREMENTS ON OUTPUT PINS

| AC CHARACTERISTICS | | | Standard Operating Conditions: 2.1V to 3.6V (unless otherwise stated) Operating temperature $-40^\circ\text{C} \leq T_A \leq +85^\circ\text{C}$ for Industrial $-40^\circ\text{C} \leq T_A \leq +125^\circ\text{C}$ for Extended | | | | |
|--------------------|--------|--|---|------------------------|------|-------|--|
| Param. No. | Symbol | Characteristics | Min. | Typical ⁽¹⁾ | Max. | Units | Conditions |
| DO50 | Cosco | OSC2 Pin | — | — | 15 | pF | In HS mode when the external clock is used to drive OSC1 |
| DO56 | CL | All I/O pins (except pins used as CxOUT) | — | — | 50 | pF | EC mode for OSC2 |
| DO58 | CB | SCLx, SDAx | — | — | 400 | pF | In I ² C™ mode |
| DO59 | CSQI | All SQI pins | — | — | 10 | pF | — |

Note 1: Data in "Typical" column is at 3.3V, +25°C unless otherwise stated. Parameters are for design guidance only and are not tested.

PIC32MZ Embedded Connectivity with Floating Point Unit (EF) Family

FIGURE 37-2: EXTERNAL CLOCK TIMING

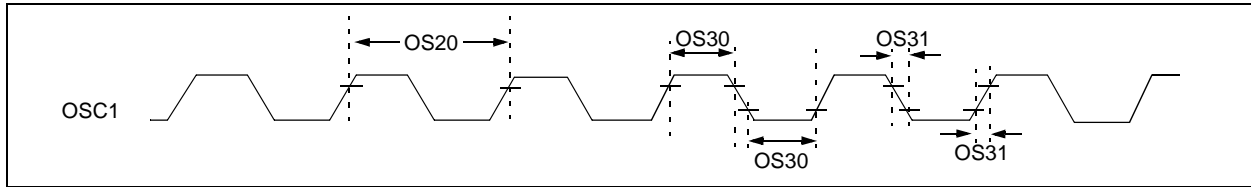

TABLE 37-17: EXTERNAL CLOCK TIMING REQUIREMENTS

| AC CHARACTERISTICS | | | Standard Operating Conditions: 2.1V to 3.6V (unless otherwise stated) Operating temperature -40°C ≤ TA ≤ +85°C for Industrial -40°C ≤ TA ≤ +125°C for Extended | | | | |
|--------------------|---------------|--|---|------------------------|---------|-------|---|
| Param. No. | Symbol | Characteristics | Minimum | Typical ⁽¹⁾ | Maximum | Units | Conditions |
| OS10 | Fosc | External CLKI Frequency (External clocks allowed only in EC and ECPLL modes) | DC | — | 64 | MHz | EC (Note 2,3) |
| OS13 | Fosc | Oscillator Crystal Frequency | 4 | — | 32 | MHz | HS (Note 2,3) |
| OS15 | | | 32 | 32.768 | 100 | kHz | Sosc (Note 2) |
| OS20 | Tosc | Tosc = 1/Fosc | — | — | — | — | See parameter OS10 for Fosc value |
| OS30 | TosL, TosH | External Clock In (OSC1) High or Low Time | 0.375 x Tosc | — | — | ns | EC (Note 2) |
| OS31 | TosR, TosF | External Clock In (OSC1) Rise or Fall Time | — | — | 7.5 | ns | EC (Note 2) |
| OS40 | TOST | Oscillator Start-up Timer Period (Only applies to HS, HSPLL, and Sosc Clock Oscillator modes) | — | 1024 | — | Tosc | (Note 2) |
| OS41 | TFSCM | Primary Clock Fail Safe Time-out Period | — | 2 | — | ms | (Note 2) |
| OS42 | GM | External Oscillator Transconductance | — | 400 | — | μA/V | VDD = 3.3V, TA = +25°C, HS (Note 2) |

Note 1: Data in "Typical" column is at 3.3V, +25°C unless otherwise stated. Parameters are characterized but are not tested.

2: This parameter is characterized, but not tested in manufacturing.

3: See parameter [OS50](#) for PLL input frequency limitations.

PIC32MZ Embedded Connectivity with Floating Point Unit (EF) Family

TABLE 37-18: SYSTEM TIMING REQUIREMENTS

| AC CHARACTERISTICS | | | Standard Operating Conditions: 2.1V to 3.6V (unless otherwise stated) Operating temperature -40°C ≤ TA ≤ +85°C for Industrial -40°C ≤ TA ≤ +125°C for Extended | | | | |
|--------------------|--------|---------------------------|---|---------|---------|-------|--|
| Param. No. | Symbol | Characteristics | Minimum | Typical | Maximum | Units | Conditions |
| OS51 | FSYS | System Frequency | DC | — | 200 | MHz | USB module disabled |
| | | | 30 | — | 200 | MHz | USB module enabled |
| OS55a | FPB | Peripheral Bus Frequency | DC | — | 100 | MHz | For PBCLKx, 'x' ≠ 7 |
| OS55b | | | DC | — | 200 | MHz | For PBCLK7 |
| OS56 | FREF | Reference Clock Frequency | — | — | 50 | MHz | For REFCLK1, 3, 4 and REFCLK0, 3, 4 pins |

TABLE 37-19: PLL CLOCK TIMING SPECIFICATIONS

| AC CHARACTERISTICS | | | Standard Operating Conditions: 2.1V to 3.6V (unless otherwise stated) Operating temperature -40°C ≤ TA ≤ +85°C for Industrial -40°C ≤ TA ≤ +125°C for Extended | | | | |
|--------------------|--------|--|---|---------|-------|-------|-----------------------------|
| Param. No. | Symbol | Characteristics ⁽¹⁾ | Min. | Typical | Max. | Units | Conditions |
| OS50 | FIN | PLL Input Frequency Range | 5 | — | 64 | MHz | ECPLL, HSPLL, FRCPLL modes |
| OS52 | TLOCK | PLL Start-up Time (Lock Time) | — | — | 100 | µs | — |
| OS53 | DCLK | CLKO Stability ⁽²⁾ (Period Jitter or Cumulative) | -0.25 | — | +0.25 | % | Measured over 100 ms period |
| OS54 | FVCO | PLL VCO Frequency Range | 350 | — | 700 | MHz | — |
| OS54a | FPLL | PLL Output Frequency Range | 10 | — | 200 | MHz | — |

Note 1: These parameters are characterized, but not tested in manufacturing.

2: This jitter specification is based on clock-cycle by clock-cycle measurements. To get the effective jitter for individual time-bases on communication clocks, use the following formula:

$$EffectiveJitter = \frac{D_{CLK}}{\sqrt{\frac{PBCLK2}{CommunicationClock}}}$$

For example, if PBCLK2 = 100 MHz and SPI bit rate = 50 MHz, the effective jitter is as follows:

$$EffectiveJitter = \frac{D_{CLK}}{\sqrt{\frac{100}{50}}} = \frac{D_{CLK}}{1.41}$$

PIC32MZ Embedded Connectivity with Floating Point Unit (EF) Family

TABLE 37-20: INTERNAL FRC ACCURACY

| AC CHARACTERISTICS | | Standard Operating Conditions: 2.1V to 3.6V (unless otherwise stated) Operating temperature -40°C ≤ TA ≤ +85°C for Industrial -40°C ≤ TA ≤ +125°C for Extended | | | | |
|---|-----------------|---|------|------|-------|--------------------|
| Param. No. | Characteristics | Min. | Typ. | Max. | Units | Conditions |
| Internal FRC Accuracy @ 8.00 MHz⁽¹⁾ | | | | | | |
| F20 | FRC | -5 | — | +5 | % | 0°C ≤ TA ≤ +85°C |
| | | -8 | — | +8 | % | -40°C ≤ TA ≤ +85°C |

Note 1: Frequency calibrated at +25°C and 3.3V. The TUN bits (OSCTUN<5:0>) can be used to compensate for temperature drift.

TABLE 37-21: INTERNAL LPRC ACCURACY

| AC CHARACTERISTICS | | Standard Operating Conditions: 2.1V to 3.6V (unless otherwise stated) Operating temperature -40°C ≤ TA ≤ +85°C for Industrial -40°C ≤ TA ≤ +125°C for Extended | | | | |
|---|-----------------|---|------|------|-------|--------------------|
| Param. No. | Characteristics | Min. | Typ. | Max. | Units | Conditions |
| Internal LPRC @ 32.768 kHz⁽¹⁾ | | | | | | |
| F21 | LPRC | -8 | — | +8 | % | 0°C ≤ TA ≤ +85°C |
| | | -25 | — | +25 | % | -40°C ≤ TA ≤ +85°C |

Note 1: Change of LPRC frequency as VDD changes.

TABLE 37-22: INTERNAL BACKUP FRC (BFRC) ACCURACY

| AC CHARACTERISTICS | | Standard Operating Conditions: 2.1V to 3.6V (unless otherwise stated) Operating temperature -40°C ≤ TA ≤ +85°C for Industrial -40°C ≤ TA ≤ +125°C for Extended | | | | |
|---|-----------------|---|------|------|-------|------------|
| Param. No. | Characteristics | Min. | Typ. | Max. | Units | Conditions |
| Internal BFRC Accuracy @ 8 MHz¹ | | | | | | |
| F22 | BFRC | — | ±30 | — | % | — |

FIGURE 37-3: I/O TIMING CHARACTERISTICS

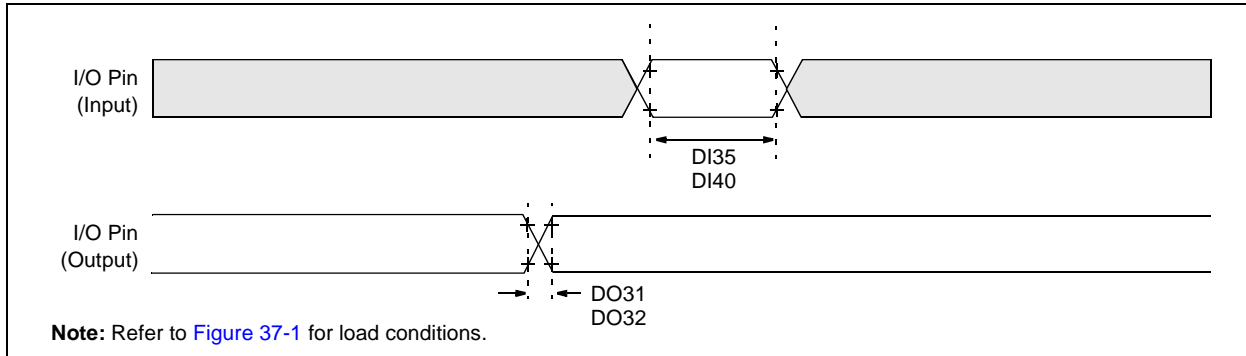

PIC32MZ Embedded Connectivity with Floating Point Unit (EF) Family

TABLE 37-23: I/O TIMING REQUIREMENTS

| AC CHARACTERISTICS | | Standard Operating Conditions: 2.1V to 3.6V (unless otherwise stated) Operating temperature -40°C ≤ TA ≤ +85°C for Industrial -40°C ≤ TA ≤ +125°C for Extended | | | | | |
|--------------------|--------|---|------|---------------------|------|-------|---------------|
| Param. No. | Symbol | Characteristics ⁽²⁾ | Min. | Typ. ⁽¹⁾ | Max. | Units | Conditions |
| DO31 | TioR | Port Output Rise Time I/O Pins: 4x Source Driver Pins - RA3, RA9, RA10, RA14, RA15 RB0-RB2, RB4, RB6-RB7, RB11, RB13 RC12-RC15 RD0, RD6-RD7, RD11, RD14 RE8, RE9 RF2, RF3, RF8 RG15 RH0, RH1, RH4-RH6, RH8-RH13 RJ0-RJ2, RJ8, RJ9, RJ11 | — | — | 9.5 | ns | CLOAD = 50 pF |
| | | Port Output Rise Time I/O Pins: 8x Source Driver Pins - RA0-RA2, RA4, RA5 RB3, RB5, RB8-RB10, RB12, RB14, RB15 RC1-RC4 RD1-RD5, RD9, RD10, RD12, RD13, RD15 RE4-RE7 RF0, RF4, RF5, RF12, RF13 RG0, RG1, RG6-RG9 RH2, RH3, RH7, RH14, RH15 RJ3-RJ7, RJ10, RJ12-RJ15 RK0-RK7 | — | — | 8 | ns | CLOAD = 50 pF |
| | | Port Output Rise Time I/O Pins: 12x Source Driver Pins - RA6, RA7 RE0-RE3 RF1 RG12-RG14 | — | — | 3.5 | ns | CLOAD = 50 pF |
| | | | — | — | 2 | ns | CLOAD = 20 pF |
| | | | — | — | 6 | ns | CLOAD = 20 pF |

Note 1: Data in "Typical" column is at 3.3V, +25°C unless otherwise stated.

Note 2: This parameter is characterized, but not tested in manufacturing.

PIC32MZ Embedded Connectivity with Floating Point Unit (EF) Family

TABLE 37-23: I/O TIMING REQUIREMENTS (CONTINUED)

| AC CHARACTERISTICS | | Standard Operating Conditions: 2.1V to 3.6V (unless otherwise stated) Operating temperature -40°C ≤ TA ≤ +85°C for Industrial -40°C ≤ TA ≤ +125°C for Extended | | | | | |
|--------------------|--------|---|------|---------------------|------|-------|---------------|
| Param. No. | Symbol | Characteristics ⁽²⁾ | Min. | Typ. ⁽¹⁾ | Max. | Units | Conditions |
| DO32 | TioF | Port Output Fall Time I/O Pins: 4x Source Driver Pins - RA3, RA9, RA10, RA14, RA15 RB0-RB2, RB4, RB6-RB7, RB11, RB13 RC12-RC15 RD0, RD6-RD7, RD11, RD14 RE8, RE9 RF2, RF3, RF8 RG15 RH0, RH1, RH4-RH6, RH8-RH13 RJ0-RJ2, RJ8, RJ9, RJ11 | — | — | 9.5 | ns | CLOAD = 50 pF |
| | | Port Output Fall Time I/O Pins: 8x Source Driver Pins - RA0-RA2, RA4, RA5 RB3, RB5, RB8-RB10, RB12, RB14, RB15 RC1-RC4 RD1-RD5, RD9, RD10, RD12, RD13, RD15 RE4-RE7 RF0, RF4, RF5, RF12, RF13 RG0, RG1, RG6-RG9 RH2, RH3, RH7, RH14, RH15 RJ3-RJ7, RJ10, RJ12-RJ15 RK0-RK7 | — | — | 6 | ns | CLOAD = 20 pF |
| | | Port Output Fall Time I/O Pins: 8x Source Driver Pins - RA0-RA2, RA4, RA5 RB3, RB5, RB8-RB10, RB12, RB14, RB15 RC1-RC4 RD1-RD5, RD9, RD10, RD12, RD13, RD15 RE4-RE7 RF0, RF4, RF5, RF12, RF13 RG0, RG1, RG6-RG9 RH2, RH3, RH7, RH14, RH15 RJ3-RJ7, RJ10, RJ12-RJ15 RK0-RK7 | — | — | 8 | ns | CLOAD = 50 pF |
| | | Port Output Fall Time I/O Pins: 12x Source Driver Pins - RA6, RA7 RE0-RE3 RF1 RG12-RG14 | — | — | 3.5 | ns | CLOAD = 50 pF |
| | | Port Output Fall Time I/O Pins: 12x Source Driver Pins - RA6, RA7 RE0-RE3 RF1 RG12-RG14 | — | — | 2 | ns | CLOAD = 20 pF |
| DI35 | TINP | INTx Pin High or Low Time | 5 | — | — | ns | — |
| DI40 | TRBP | CNx High or Low Time (input) | 5 | — | — | ns | — |

Note 1: Data in "Typical" column is at 3.3V, +25°C unless otherwise stated.

Note 2: This parameter is characterized, but not tested in manufacturing.

PIC32MZ Embedded Connectivity with Floating Point Unit (EF) Family

FIGURE 37-4: POWER-ON RESET TIMING CHARACTERISTICS

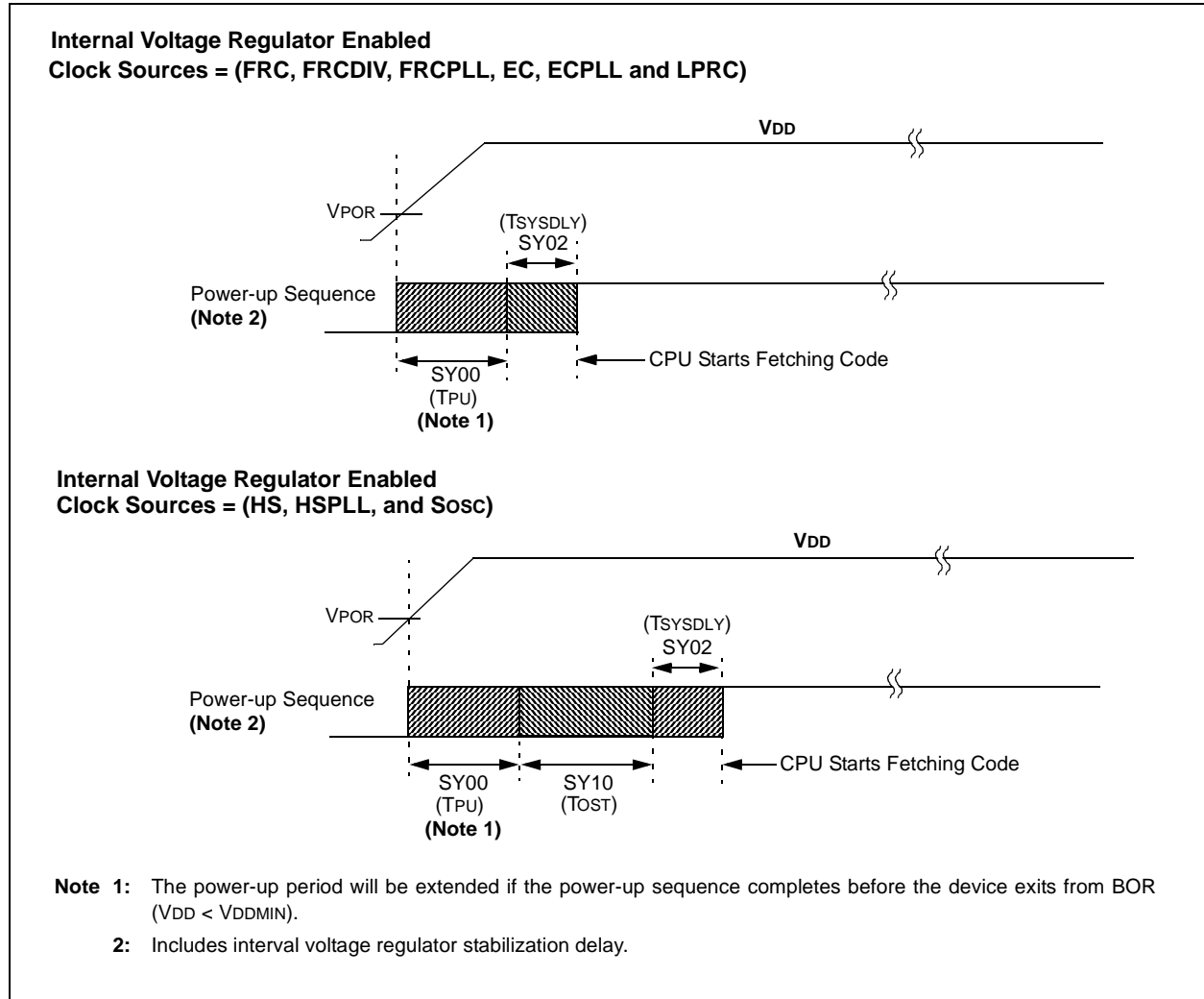

PIC32MZ Embedded Connectivity with Floating Point Unit (EF) Family

FIGURE 37-5: EXTERNAL RESET TIMING CHARACTERISTICS

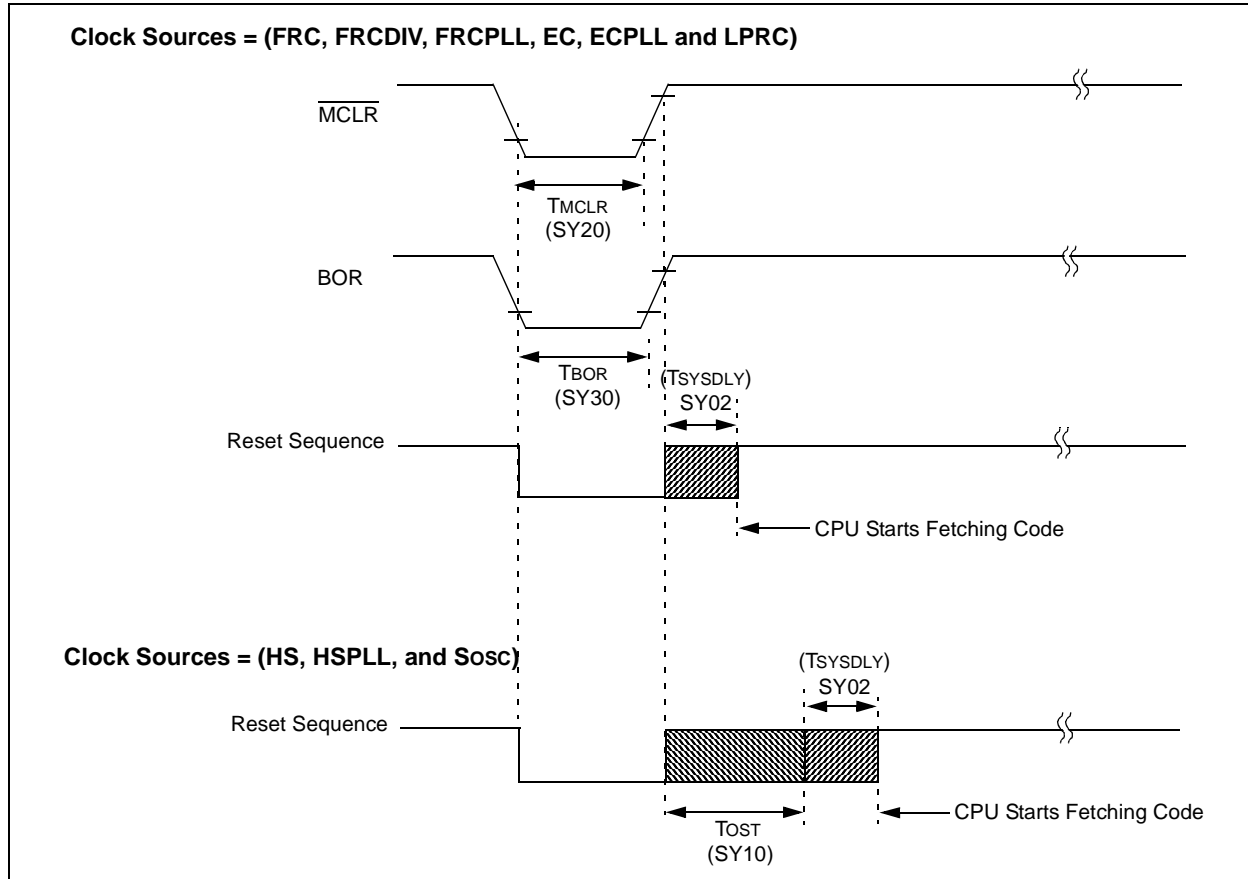

TABLE 37-24: RESETS TIMING

| AC CHARACTERISTICS | | | Standard Operating Conditions: 2.1V to 3.6V (unless otherwise stated) Operating temperature $-40^{\circ}\text{C} \leq T_A \leq +85^{\circ}\text{C}$ for Industrial $-40^{\circ}\text{C} \leq T_A \leq +125^{\circ}\text{C}$ for Extended | | | | |
|--------------------|---------|--|---|---|------|---------------|------------|
| Param. No. | Symbol | Characteristics ⁽¹⁾ | Min. | Typical ⁽²⁾ | Max. | Units | Conditions |
| SY00 | TPU | Power-up Period Internal Voltage Regulator Enabled | — | 400 | 600 | μs | — |
| SY02 | TSYSDLY | System Delay Period: Time Required to Reload Device Configuration Fuses plus SYSCLOCK Delay before First instruction is Fetched. | — | $1 \mu\text{s} +$ 8 SYSCLOCK cycles | — | — | — |
| SY20 | TMCLR | MCLR Pulse Width (low) | 2 | — | — | μs | — |
| SY30 | TBOR | BOR Pulse Width (low) | — | 1 | — | μs | — |

Note 1: These parameters are characterized, but not tested in manufacturing.

Note 2: Data in "Typ" column is at 3.3V, +25°C unless otherwise stated. Characterized by design but not tested.

PIC32MZ Embedded Connectivity with Floating Point Unit (EF) Family

FIGURE 37-6: TIMER1-TIMER9 EXTERNAL CLOCK TIMING CHARACTERISTICS

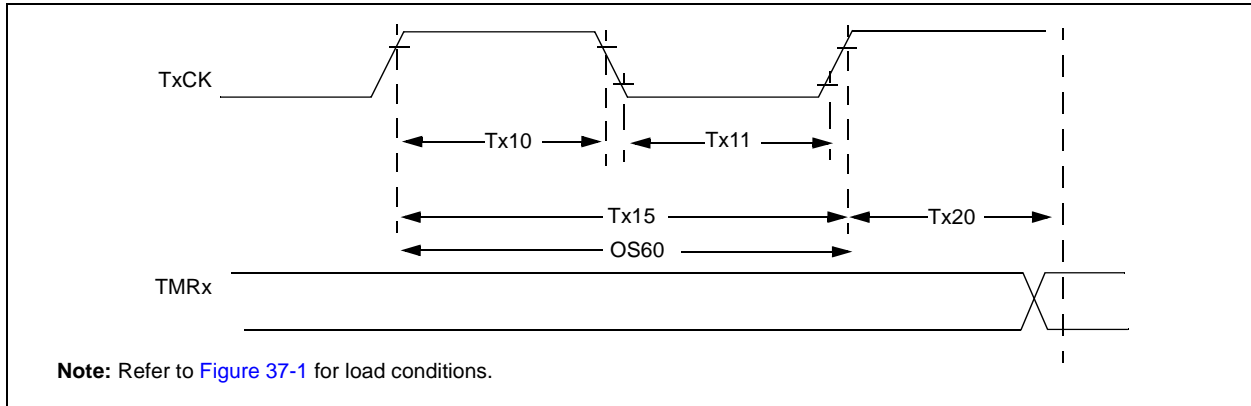

TABLE 37-25: TIMER1 EXTERNAL CLOCK TIMING REQUIREMENTS⁽¹⁾

| AC CHARACTERISTICS | | | Standard Operating Conditions: 2.1V to 3.6V (unless otherwise stated) Operating temperature -40°C ≤ TA ≤ +85°C for Industrial -40°C ≤ TA ≤ +125°C for Extended | | | | | |
|--------------------|-----------|--|---|---|------|---------------------|------------|--|
| Param. No. | Symbol | Characteristics ⁽²⁾ | Min. | Typ. | Max. | Units | Conditions | |
| TA10 | TtxH | TxCK High Time | Synchronous, with prescaler | $[(12.5 \text{ ns or } 1 \text{ TPBCLK}_3) / N] + 20 \text{ ns}$ | — | — | ns | Must also meet parameter TA15 (Note 3) |
| | | Asynchronous, with prescaler | 10 | — | — | ns | — | |
| TA11 | TtxL | TxCK Low Time | Synchronous, with prescaler | $[(12.5 \text{ ns or } 1 \text{ TPBCLK}_3) / N] + 20 \text{ ns}$ | — | — | ns | Must also meet parameter TA15 (Note 3) |
| | | Asynchronous, with prescaler | 10 | — | — | ns | — | |
| TA15 | TtxP | TxCK Input Period | Synchronous, with prescaler | $[(\text{Greater of } 20 \text{ ns or } 2 \text{ TPBCLK}_3) / N] + 30 \text{ ns}$ | — | — | ns | VDD > 2.7V (Note 3) |
| | | | Asynchronous, with prescaler | $[(\text{Greater of } 20 \text{ ns or } 2 \text{ TPBCLK}_3) / N] + 50 \text{ ns}$ | — | — | ns | VDD < 2.7V (Note 3) |
| | | Asynchronous, with prescaler | 20 | — | — | ns | VDD > 2.7V | |
| OS60 | Ft1 | SOSC1/T1CK Oscillator Input Frequency Range (oscillator enabled by setting TCS bit (T1CON<1>)) | 32 | — | 50 | kHz | — | |
| TA20 | TCKEXTMRL | Delay from External TxCK Clock Edge to Timer Increment | — | — | 1 | TPBCLK ₃ | — | |

Note 1: Timer1 is a Type A timer.

2: This parameter is characterized, but not tested in manufacturing.

3: N = Prescale Value (1, 8, 64, 256).

PIC32MZ Embedded Connectivity with Floating Point Unit (EF) Family

TABLE 37-26: TIMER2-TIMER9 EXTERNAL CLOCK TIMING REQUIREMENTS

| AC CHARACTERISTICS | | Standard Operating Conditions: 2.1V to 3.6V (unless otherwise stated) Operating temperature -40°C ≤ TA ≤ +85°C for Industrial -40°C ≤ TA ≤ +125°C for Extended | | | | | |
|--------------------|-----------------------|---|-----------------------------|---|------|---------------------|---|
| Param. No. | Symbol | Characteristics ⁽¹⁾ | | Min. | Max. | Units | Conditions |
| TB10 | T _{TXH} | TxCK High Time | Synchronous, with prescaler | $[(12.5 \text{ ns or } 1 \text{ TPBCLK}_3) / N] + 25 \text{ ns}$ | — | ns | Must also meet parameter TB15 N = prescale value (1, 2, 4, 8, 16, 32, 64, 256) |
| TB11 | T _{TXL} | TxCK Low Time | Synchronous, with prescaler | $[(12.5 \text{ ns or } 1 \text{ TPBCLK}_3) / N] + 25 \text{ ns}$ | — | ns | Must also meet parameter TB15 |
| TB15 | T _{TXP} | TxCK Input Period | Synchronous, with prescaler | $[(\text{Greater of } [(25 \text{ ns or } 2 \text{ TPBCLK}_3) / N] + 30 \text{ ns})]$ | — | ns | V _{DD} > 2.7V |
| | | | | $[(\text{Greater of } [(25 \text{ ns or } 2 \text{ TPBCLK}_3) / N] + 50 \text{ ns})]$ | — | ns | V _{DD} < 2.7V |
| TB20 | T _{CKEXTMRL} | Delay from External TxCK Clock Edge to Timer Increment | | — | 1 | TPBCLK ₃ | — |

Note 1: These parameters are characterized, but not tested in manufacturing.

FIGURE 37-7: INPUT CAPTURE (CAP_x) TIMING CHARACTERISTICS

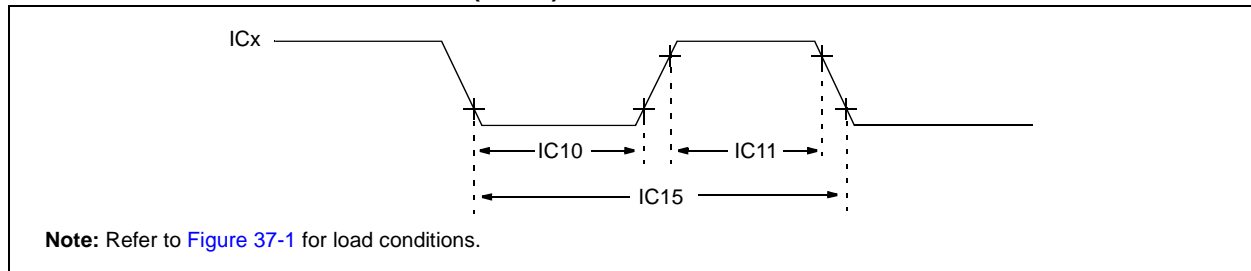

TABLE 37-27: INPUT CAPTURE MODULE TIMING REQUIREMENTS

| AC CHARACTERISTICS | | Standard Operating Conditions: 2.1V to 3.6V (unless otherwise stated) Operating temperature -40°C ≤ TA ≤ +85°C for Industrial -40°C ≤ TA ≤ +125°C for Extended | | | | | |
|--------------------|------------------|---|--|--|------|-------|---|
| Param. No. | Symbol | Characteristics ⁽¹⁾ | | Min. | Max. | Units | Conditions |
| IC10 | T _{cCL} | IC _x Input Low Time | | $[(12.5 \text{ ns or } 1 \text{ TPBCLK}_3) / N] + 25 \text{ ns}$ | — | ns | Must also meet parameter IC15. N = prescale value (1, 4, 16) |
| IC11 | T _{cCH} | IC _x Input High Time | | $[(12.5 \text{ ns or } 1 \text{ TPBCLK}_3) / N] + 25 \text{ ns}$ | — | ns | Must also meet parameter IC15. |
| IC15 | T _{cCP} | IC _x Input Period | | $[(25 \text{ ns or } 2 \text{ TPBCLK}_3) / N] + 50 \text{ ns}$ | — | ns | — |

Note 1: These parameters are characterized, but not tested in manufacturing.

PIC32MZ Embedded Connectivity with Floating Point Unit (EF) Family

FIGURE 37-8: OUTPUT COMPARE MODULE (OCx) TIMING CHARACTERISTICS

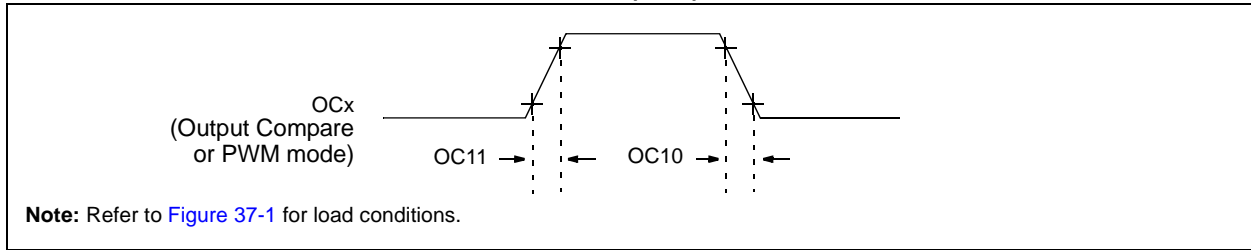

TABLE 37-28: OUTPUT COMPARE MODULE TIMING REQUIREMENTS

| AC CHARACTERISTICS | | | Standard Operating Conditions: 2.1V to 3.6V (unless otherwise stated) Operating temperature $-40^{\circ}\text{C} \leq T_A \leq +85^{\circ}\text{C}$ for Industrial $-40^{\circ}\text{C} \leq T_A \leq +125^{\circ}\text{C}$ for Extended | | | | |
|--------------------|--------|--------------------------------|---|------------------------|------|-------|--------------------|
| Param. No. | Symbol | Characteristics ⁽¹⁾ | Min. | Typical ⁽²⁾ | Max. | Units | Conditions |
| OC10 | TccF | OCx Output Fall Time | — | — | — | ns | See parameter DO32 |
| OC11 | TccR | OCx Output Rise Time | — | — | — | ns | See parameter DO31 |

Note 1: These parameters are characterized, but not tested in manufacturing.

Note 2: Data in “Typical” column is at 3.3V, +25°C unless otherwise stated. Parameters are for design guidance only and are not tested.

FIGURE 37-9: OCx/PWM MODULE TIMING CHARACTERISTICS

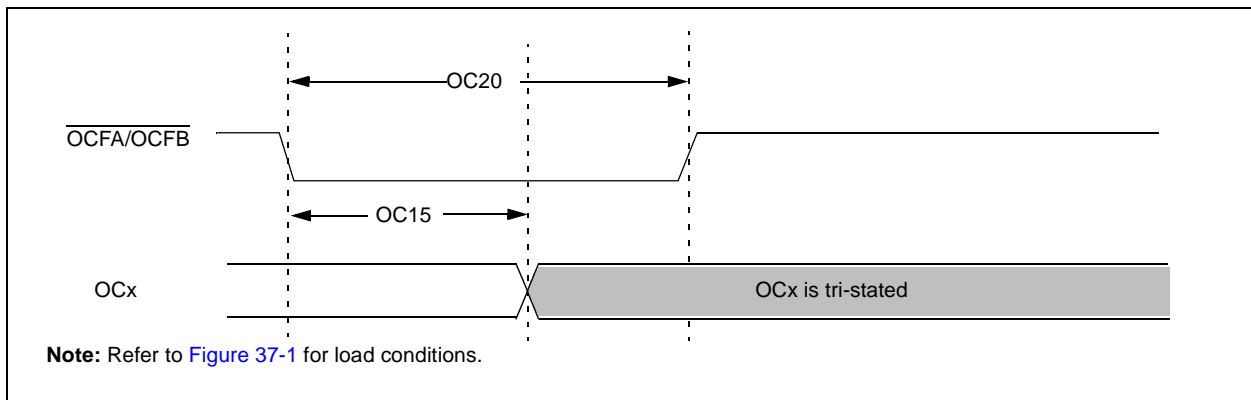

TABLE 37-29: SIMPLE OCx/PWM MODE TIMING REQUIREMENTS

| AC CHARACTERISTICS | | | Standard Operating Conditions: 2.1V to 3.6V (unless otherwise stated) Operating temperature $-40^{\circ}\text{C} \leq T_A \leq +85^{\circ}\text{C}$ for Industrial $-40^{\circ}\text{C} \leq T_A \leq +125^{\circ}\text{C}$ for Extended | | | | |
|--------------------|--------|--------------------------------|---|------------------------|-----|-------|------------|
| Param No. | Symbol | Characteristics ⁽¹⁾ | Min | Typical ⁽²⁾ | Max | Units | Conditions |
| OC15 | TFD | Fault Input to PWM I/O Change | — | — | 50 | ns | — |
| OC20 | TFLT | Fault Input Pulse Width | 50 | — | — | ns | — |

Note 1: These parameters are characterized, but not tested in manufacturing.

Note 2: Data in “Typical” column is at 3.3V, +25°C unless otherwise stated. Parameters are for design guidance only and are not tested.

FIGURE 37-10: SPIx MODULE MASTER MODE (CKE = 0) TIMING CHARACTERISTICS

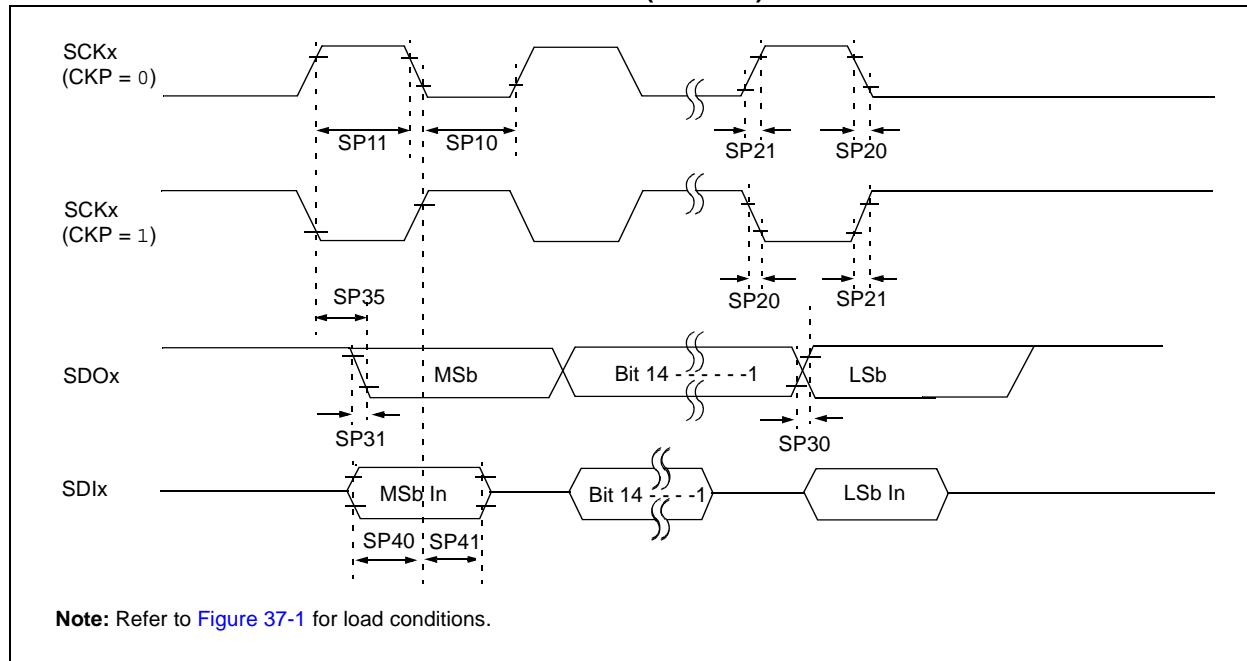

PIC32MZ Embedded Connectivity with Floating Point Unit (EF) Family

TABLE 37-30: SPIx MASTER MODE (CKE = 0) TIMING REQUIREMENTS

| AC CHARACTERISTICS | | | Standard Operating Conditions: 2.1V to 3.6V (unless otherwise stated) Operating temperature -40°C ≤ TA ≤ +85°C for Industrial -40°C ≤ TA ≤ +125°C for Extended | | | | |
|--------------------|-----------------------|---|---|----------------------------|------|---------------------------------|--|
| Param. No. | Symbol | Characteristics ⁽¹⁾ | Min. | Typ. ⁽²⁾ | Max. | Units | Conditions |
| SP10 | TsCL | SCKx Output Low Time (Note 3) | TsCK/2 | — | — | ns | — |
| SP11 | TsCH | SCKx Output High Time (Note 3) | TsCK/2 | — | — | ns | — |
| SP15 | TsCK | SPI Clock Speed (Note 5) | — | 25 50 25 50 25 | — | MHz MHz MHz MHz MHz | SPI1, SPI4 through SPI6 SPI2 on RPB3, RPB5 SPI2 on other I/O SPI3 on RPB10, RPB9, RPF0 SPI3 on other I/O |
| SP20 | TsCF | SCKx Output Fall Time (Note 4) | — | — | — | ns | See parameter DO32 |
| SP21 | TsCR | SCKx Output Rise Time (Note 4) | — | — | — | ns | See parameter DO31 |
| SP30 | TdOF | SDOx Data Output Fall Time (Note 4) | — | — | — | ns | See parameter DO32 |
| SP31 | TdOR | SDOx Data Output Rise Time (Note 4) | — | — | — | ns | See parameter DO31 |
| SP35 | TsCH2DoV, TsCL2DoV | SDOx Data Output Valid after SCKx Edge | — | — | 7 | ns | VDD > 2.7V |
| | | | — | — | 10 | ns | VDD < 2.7V |
| SP40 | TdIV2sCH, TdIV2sCL | Setup Time of SDIx Data Input to SCKx Edge | 5 | — | — | ns | — |
| SP41 | TsCH2dIL, TsCL2dIL | Hold Time of SDIx Data Input to SCKx Edge | 5 | — | — | ns | — |

- Note 1:** These parameters are characterized, but not tested in manufacturing.
- Note 2:** Data in “Typical” column is at 3.3V, +25°C unless otherwise stated. Parameters are for design guidance only and are not tested.
- Note 3:** The minimum clock period for SCKx is 20 ns. Therefore, the clock generated in Master mode must not violate this specification.
- Note 4:** Assumes 30 pF load on all SPIx pins.
- Note 5:** To achieve maximum data rate, SMP must be set to ‘1’.

FIGURE 37-11: SPIx MODULE MASTER MODE (CKE = 1) TIMING CHARACTERISTICS

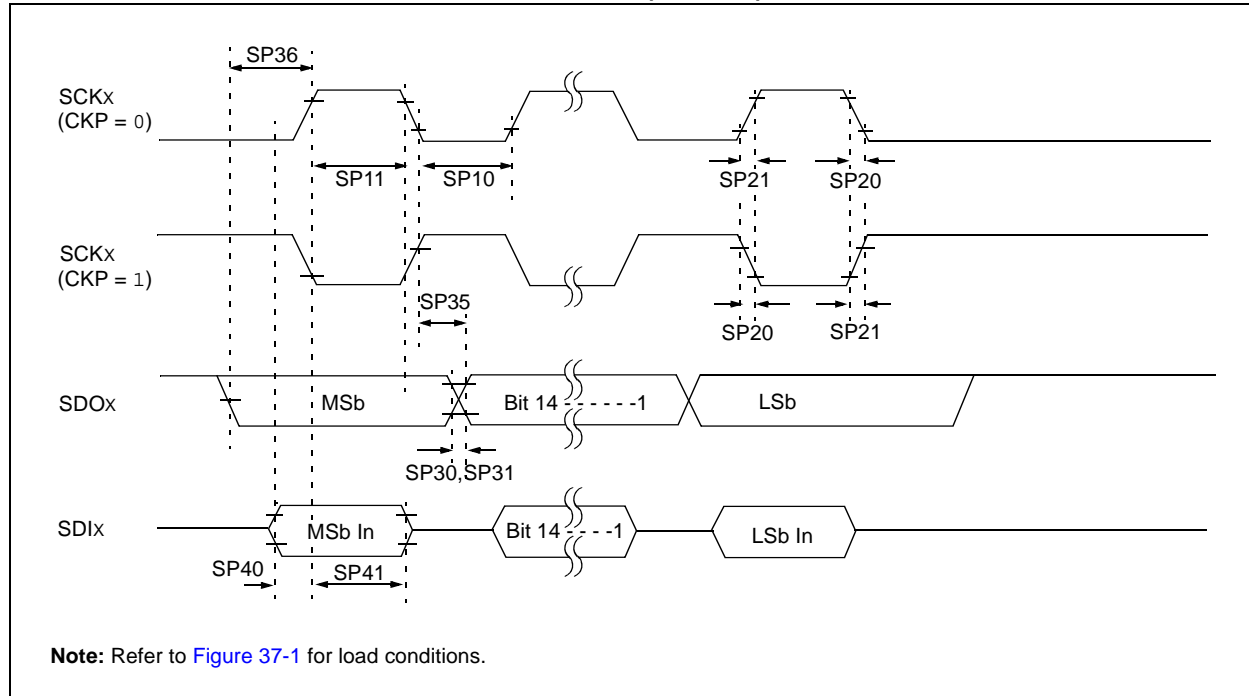

PIC32MZ Embedded Connectivity with Floating Point Unit (EF) Family

TABLE 37-31: SPIx MODULE MASTER MODE (CKE = 1) TIMING REQUIREMENTS

| AC CHARACTERISTICS | | | Standard Operating Conditions: 2.1V to 3.6V (unless otherwise stated) Operating temperature -40°C ≤ TA ≤ +85°C for Industrial -40°C ≤ TA ≤ +125°C for Extended | | | | |
|--------------------|-----------------------|---|---|----------------------------|------|---------------------------------|--|
| Param. No. | Symbol | Characteristics ⁽¹⁾ | Min. | Typ. ⁽²⁾ | Max. | Units | Conditions |
| SP10 | TscL | SCKx Output Low Time (Note 3) | Tsck/2 | — | — | ns | — |
| SP11 | TscH | SCKx Output High Time (Note 3) | Tsck/2 | — | — | ns | — |
| SP15 | Tsck | SPI Clock Speed (Note 5) | — | 25 50 25 50 25 | — | MHz MHz MHz MHz MHz | SPI1, SPI4 through SPI6 SPI2 on RPB3, RPB5 SPI2 on other I/O SPI3 on RPB10, RPB9, RPF0 SPI3 on other I/O |
| SP20 | TscF | SCKx Output Fall Time (Note 4) | — | — | — | ns | See parameter DO32 |
| SP21 | TscR | SCKx Output Rise Time (Note 4) | — | — | — | ns | See parameter DO31 |
| SP30 | TdoF | SDOx Data Output Fall Time (Note 4) | — | — | — | ns | See parameter DO32 |
| SP31 | TdoR | SDOx Data Output Rise Time (Note 4) | — | — | — | ns | See parameter DO31 |
| SP35 | Tsch2doV, TscL2doV | SDOx Data Output Valid after SCKx Edge | — | — | 7 | ns | VDD > 2.7V |
| | | | — | — | 10 | ns | VDD < 2.7V |
| SP36 | TdoV2sc, TdoV2scL | SDOx Data Output Setup to First SCKx Edge | 7 | — | — | ns | — |
| SP40 | TdiV2sch, TdiV2scL | Setup Time of SDIx Data Input to SCKx Edge | 7 | — | — | ns | VDD > 2.7V |
| | | | 10 | — | — | ns | VDD < 2.7V |
| SP41 | Tsch2diL, TscL2diL | Hold Time of SDIx Data Input to SCKx Edge | 7 | — | — | ns | VDD > 2.7V |
| | | | 10 | — | — | ns | VDD < 2.7V |

- Note 1:** These parameters are characterized, but not tested in manufacturing.
- 2:** Data in “Typical” column is at 3.3V, +25°C unless otherwise stated. Parameters are for design guidance only and are not tested.
- 3:** The minimum clock period for SCKx is 20 ns. Therefore, the clock generated in Master mode must not violate this specification.
- 4:** Assumes 30 pF load on all SPIx pins.
- 5:** To achieve maximum data rate, SMP must be set to ‘1’.

PIC32MZ Embedded Connectivity with Floating Point Unit (EF) Family

FIGURE 37-12: SPIx MODULE SLAVE MODE (CKE = 0) TIMING CHARACTERISTICS

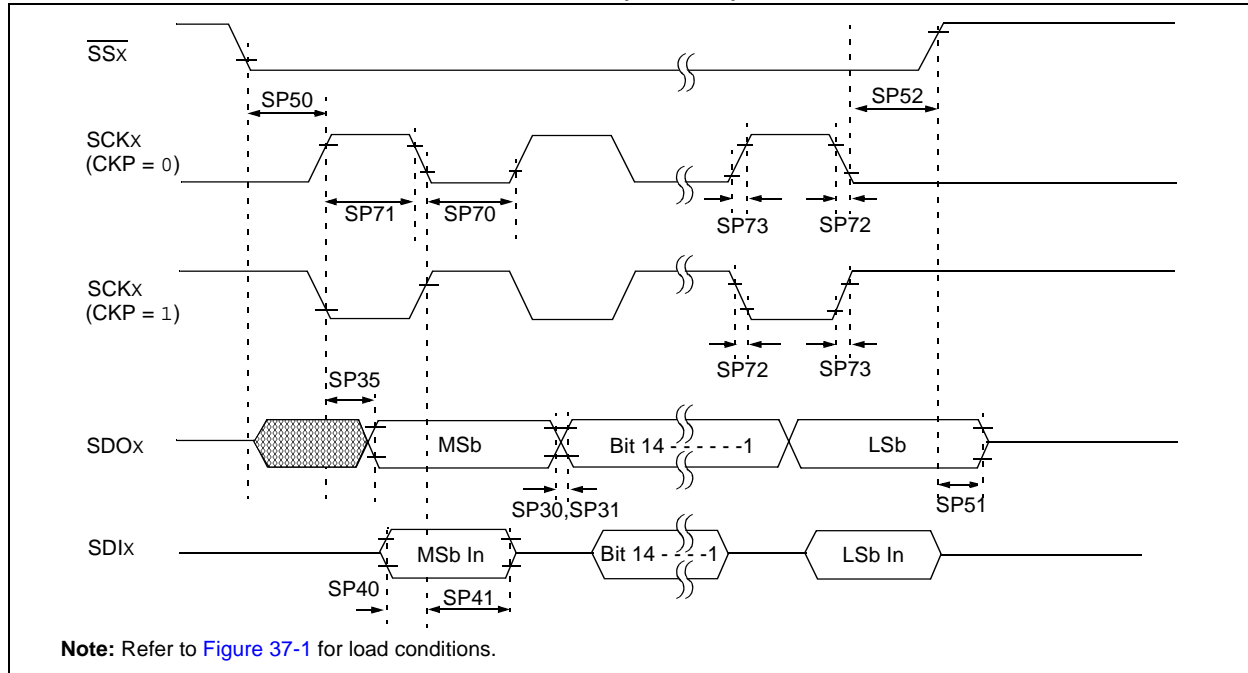

TABLE 37-32: SPIx MODULE SLAVE MODE (CKE = 0) TIMING REQUIREMENTS

| AC CHARACTERISTICS | | | Standard Operating Conditions: 2.1V to 3.6V (unless otherwise stated) Operating temperature $-40^{\circ}\text{C} \leq T_A \leq +85^{\circ}\text{C}$ for Industrial $-40^{\circ}\text{C} \leq T_A \leq +125^{\circ}\text{C}$ for Extended | | | | |
|--------------------|-----------------------|---|---|---------------------|------|-------|------------------------------------|
| Param. No. | Symbol | Characteristics ⁽¹⁾ | Min. | Typ. ⁽²⁾ | Max. | Units | Conditions |
| SP70 | TscL | SCKx Input Low Time (Note 3) | $T_{\text{SCK}}/2$ | — | — | ns | — |
| SP71 | Tsch | SCKx Input High Time (Note 3) | $T_{\text{SCK}}/2$ | — | — | ns | — |
| SP72 | TscF | SCKx Input Fall Time | — | — | — | ns | See parameter DO32 |
| SP73 | TscR | SCKx Input Rise Time | — | — | — | ns | See parameter DO31 |
| SP30 | TdoF | SDOx Data Output Fall Time (Note 4) | — | — | — | ns | See parameter DO32 |
| SP31 | TdoR | SDOx Data Output Rise Time (Note 4) | — | — | — | ns | See parameter DO31 |
| SP35 | Tsch2boV, TscL2boV | SDOx Data Output Valid after SCKx Edge | — | — | 7 | ns | $V_{\text{DD}} > 2.7\text{V}$ |
| | | | — | — | 10 | ns | $V_{\text{DD}} < 2.7\text{V}$ |
| SP40 | TdiV2sch, TdiV2scl | Setup Time of SDIx Data Input to SCKx Edge | 5 | — | — | ns | — |
| SP41 | Tsch2dil, TscL2dil | Hold Time of SDIx Data Input to SCKx Edge | 5 | — | — | ns | — |
| SP50 | Tssl2sch, Tssl2scl | $\overline{\text{SSx}} \downarrow$ to SCKx \uparrow or SCKx Input | 88 | — | — | ns | — |
| SP51 | Tssh2doZ | $\overline{\text{SSx}} \uparrow$ to SDOx Output High-Impedance (Note 3) | 2.5 | — | 12 | ns | — |
| SP52 | Tsch2ssh, TscL2ssh | $\overline{\text{SSx}}$ after SCKx Edge | 10 | — | — | ns | — |

Note 1: These parameters are characterized, but not tested in manufacturing.

Note 2: Data in “Typical” column is at 3.3V, +25°C unless otherwise stated. Parameters are for design guidance only and are not tested.

Note 3: The minimum clock period for SCKx is 20 ns.

Note 4: Assumes 30 pF load on all SPIx pins.

PIC32MZ Embedded Connectivity with Floating Point Unit (EF) Family

FIGURE 37-13: SPIx MODULE SLAVE MODE (CKE = 1) TIMING CHARACTERISTICS

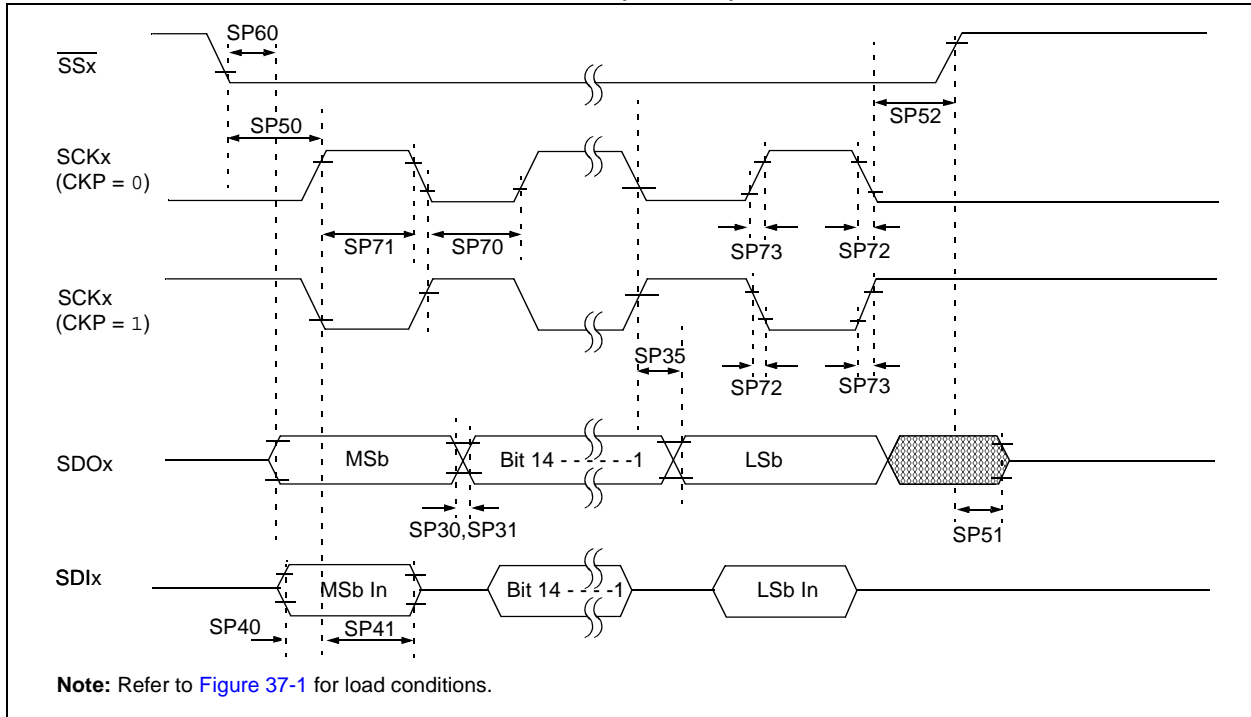

TABLE 37-33: SPIx MODULE SLAVE MODE (CKE = 1) TIMING REQUIREMENTS

| AC CHARACTERISTICS | | | Standard Operating Conditions: 2.1V to 3.6V (unless otherwise stated) Operating temperature -40°C ≤ TA ≤ +85°C for Industrial -40°C ≤ TA ≤ +125°C for Extended | | | | |
|--------------------|-----------------------|--|---|------------------------|------|-------|------------------------------------|
| Param. No. | Symbol | Characteristics ⁽¹⁾ | Min. | Typical ⁽²⁾ | Max. | Units | Conditions |
| SP70 | TscL | SCKx Input Low Time (Note 3) | Tsck/2 | — | — | ns | — |
| SP71 | TscH | SCKx Input High Time (Note 3) | Tsck/2 | — | — | ns | — |
| SP72 | TscF | SCKx Input Fall Time | — | — | 10 | ns | — |
| SP73 | TscR | SCKx Input Rise Time | — | — | 10 | ns | — |
| SP30 | TdoF | SDOx Data Output Fall Time (Note 4) | — | — | — | ns | See parameter DO32 |
| SP31 | TdoR | SDOx Data Output Rise Time (Note 4) | — | — | — | ns | See parameter DO31 |
| SP35 | Tsch2doV, TscL2doV | SDOx Data Output Valid after SCKx Edge | — | — | 10 | ns | VDD > 2.7V |
| | | | — | — | 15 | ns | VDD < 2.7V |
| SP40 | TdIV2sch, TdIV2scl | Setup Time of SDIx Data Input to SCKx Edge | 0 | — | — | ns | — |
| SP41 | Tsch2dIL, TscL2dIL | Hold Time of SDIx Data Input to SCKx Edge | 7 | — | — | ns | — |

Note 1: These parameters are characterized, but not tested in manufacturing.

Note 2: Data in "Typical" column is at 3.3V, +25°C unless otherwise stated. Parameters are for design guidance only and are not tested.

Note 3: The minimum clock period for SCKx is 20 ns.

Note 4: Assumes 30 pF load on all SPIx pins.

PIC32MZ Embedded Connectivity with Floating Point Unit (EF) Family

TABLE 37-33: SPIx MODULE SLAVE MODE (CKE = 1) TIMING REQUIREMENTS (CONTINUED)

| AC CHARACTERISTICS | | | Standard Operating Conditions: 2.1V to 3.6V (unless otherwise stated) Operating temperature -40°C ≤ TA ≤ +85°C for Industrial -40°C ≤ TA ≤ +125°C for Extended | | | | |
|--------------------|-----------------------|---|---|------------------------|------|-------|------------|
| Param. No. | Symbol | Characteristics ⁽¹⁾ | Min. | Typical ⁽²⁾ | Max. | Units | Conditions |
| SP50 | TssL2sCH, TssL2sCL | \overline{SSx} ↓ to SCKx ↓ or SCKx ↑ Input | 88 | — | — | ns | — |
| SP51 | TssH2doZ | \overline{SSx} ↑ to SDOx Output High-Impedance (Note 4) | 2.5 | — | 12 | ns | — |
| SP52 | Tsch2ssH TscL2ssH | \overline{SSx} ↑ after SCKx Edge | 10 | — | — | ns | — |
| SP60 | TssL2boV | SDOx Data Output Valid after \overline{SSx} Edge | — | — | 12.5 | ns | — |

- Note 1:** These parameters are characterized, but not tested in manufacturing.
- 2:** Data in “Typical” column is at 3.3V, +25°C unless otherwise stated. Parameters are for design guidance only and are not tested.
- 3:** The minimum clock period for SCKx is 20 ns.
- 4:** Assumes 30 pF load on all SPIx pins.

FIGURE 37-14: SQI SERIAL INPUT TIMING CHARACTERISTICS

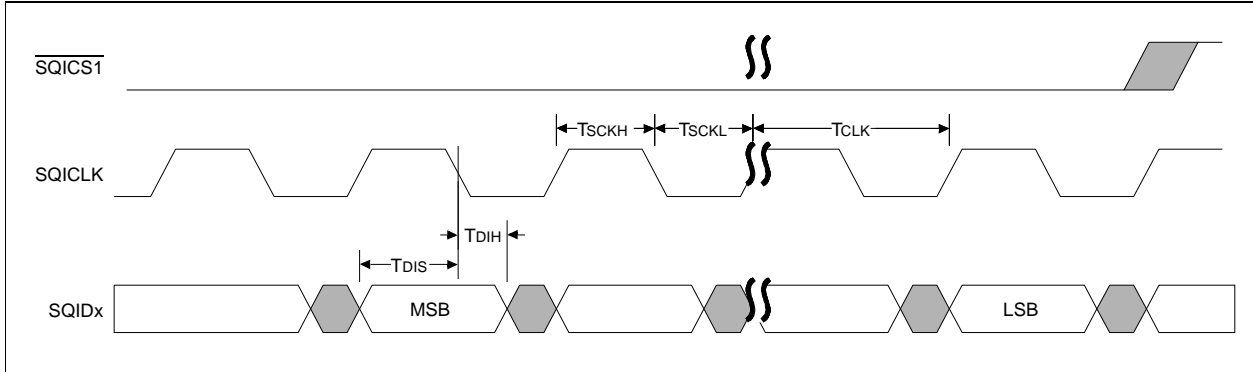
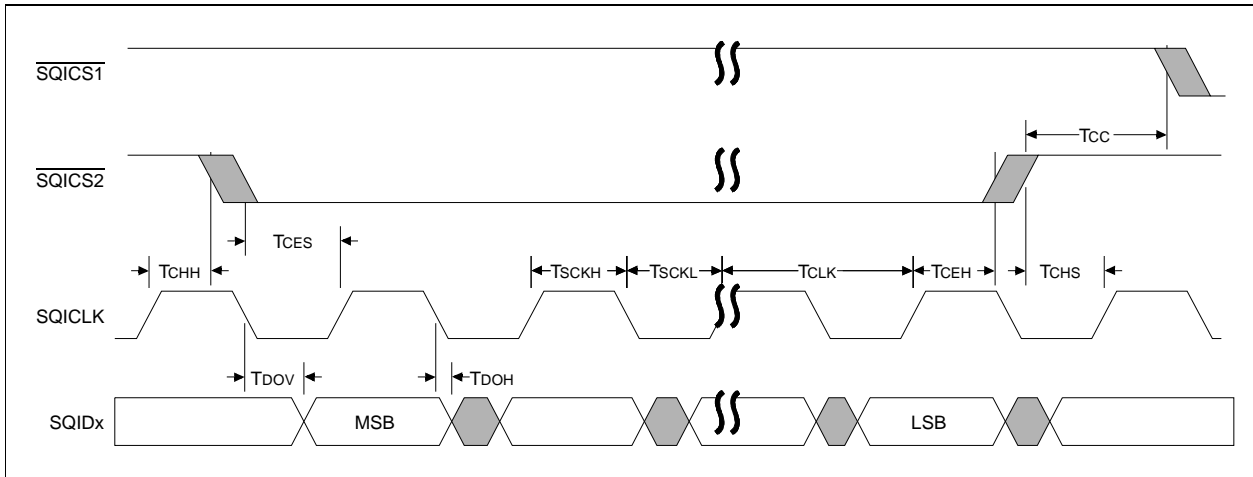

FIGURE 37-15: SQI SERIAL OUTPUT TIMING CHARACTERISTICS



PIC32MZ Embedded Connectivity with Floating Point Unit (EF) Family

TABLE 37-34: SQI TIMING REQUIREMENTS

| AC CHARACTERISTICS | | | Standard Operating Conditions: 2.1V to 3.6V (unless otherwise stated) Operating temperature -40°C ≤ TA ≤ +85°C for Industrial -40°C ≤ TA ≤ +125°C for Extended | | | | |
|--------------------|-------------|---------------------------------------|---|---------------------|------|-------|------------------------------------|
| Param. No. | Symbol | Characteristic ^(1,3) | Min. | Typ. ⁽²⁾ | Max. | Units | Conditions |
| SQ10 | FCLK | Serial Clock Frequency (1/Tsqi) | — | 66 | — | MHz | DMA mode Read, SPI mode 0 |
| | | | — | 33 | — | MHz | DMA mode Read, SPI mode 3 |
| | | | — | 100 | — | MHz | PIO mode Write |
| SQ11 | TSCKH | Serial Clock High Time | 5 | — | — | ns | — |
| SQ12 | TSCKL | Serial Clock Low Time | 5 | — | — | ns | — |
| SQ13 | TSCKR | Serial Clock Rise Time | — | — | — | ns | See parameter DO31 |
| SQ14 | TSCKF | Serial Clock Fall Time | — | — | — | ns | See parameter DO32 |
| SQ15 | Tcss (TCES) | \overline{CS} Active Setup Time | 5 | — | — | ns | — |
| SQ16 | Tcsh (TCEH) | \overline{CS} Active Hold Time | 5 | — | — | ns | — |
| SQ17 | Tchs | \overline{CS} Not Active Setup Time | 3 | — | — | ns | — |
| SQ18 | Tchh | \overline{CS} Not Active Hold Time | 3 | — | — | ns | — |
| SQ22 | Tdis | Data In Setup Time | 6 | — | — | ns | — |
| SQ23 | tdih | Data In Hold Time | 3 | — | — | ns | — |
| SQ24 | Tdoh | Data Out Hold | 0 | — | — | ns | — |
| SQ25 | Tdov | Data Out Valid | — | — | 6 | ns | — |

Note 1: These parameters are characterized, but not tested in manufacturing.

2: Data in the Typical column is at 3.3V, +25°C unless otherwise stated. Parameters are for design guidance only and are not tested.

3: Assumes 10 pF load on all SQIx pins

PIC32MZ Embedded Connectivity with Floating Point Unit (EF) Family

FIGURE 37-16: I2Cx BUS START/STOP BITS TIMING CHARACTERISTICS (MASTER MODE)

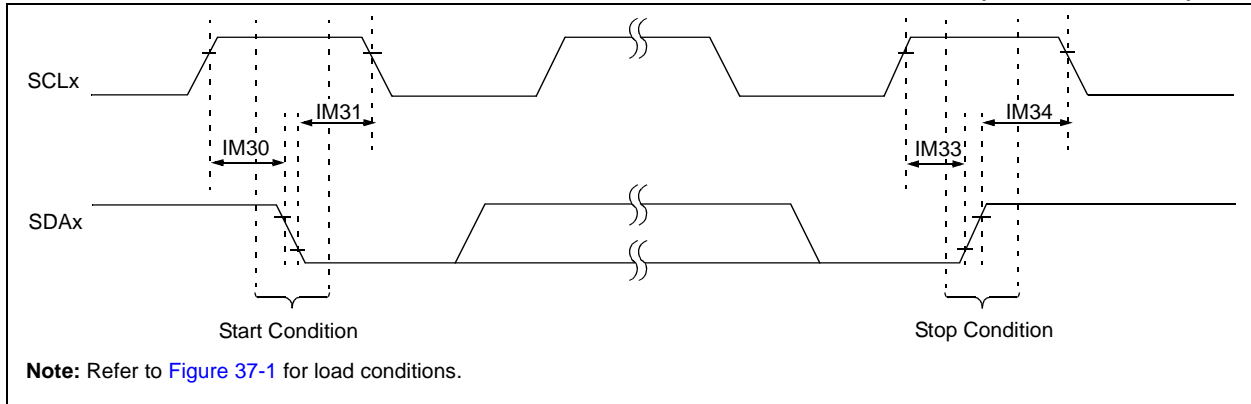

FIGURE 37-17: I2Cx BUS DATA TIMING CHARACTERISTICS (MASTER MODE)

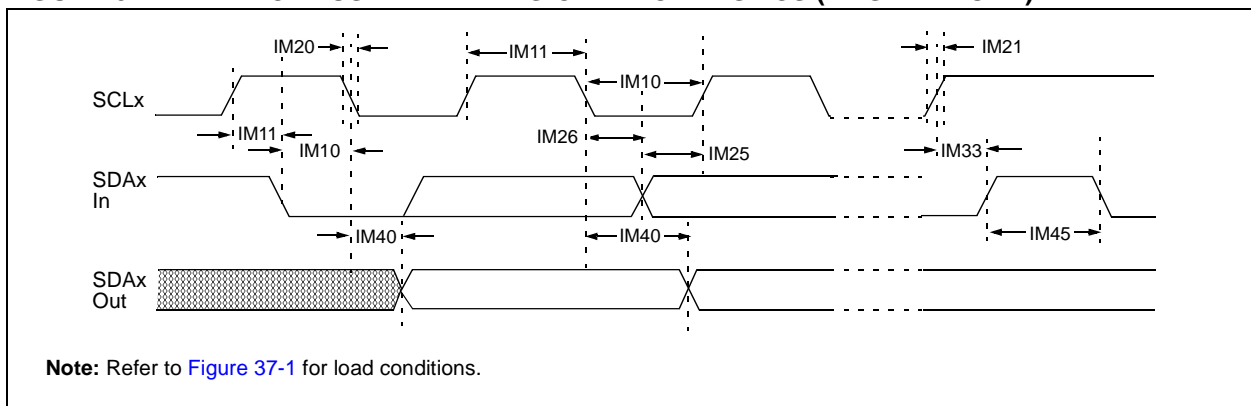

TABLE 37-35: I2Cx BUS DATA TIMING REQUIREMENTS (MASTER MODE)

| AC CHARACTERISTICS | | | Standard Operating Conditions: 2.1V to 3.6V (unless otherwise stated) Operating temperature $-40^{\circ}\text{C} \leq T_A \leq +85^{\circ}\text{C}$ for Industrial $-40^{\circ}\text{C} \leq T_A \leq +125^{\circ}\text{C}$ for Extended | | | | |
|--------------------|---------|----------------------------|---|---------------------|-------|---------------|--|
| Param. No. | Symbol | Characteristics | Min. ⁽¹⁾ | Max. | Units | Conditions | |
| IM10 | TLO:SCL | Clock Low Time | 100 kHz mode | TPBCLK2 * (BRG + 2) | — | μs | — |
| | | | 400 kHz mode | TPBCLK2 * (BRG + 2) | — | μs | — |
| | | | 1 MHz mode (Note 2) | TPBCLK2 * (BRG + 2) | — | μs | — |
| IM11 | THI:SCL | Clock High Time | 100 kHz mode | TPBCLK2 * (BRG + 2) | — | μs | — |
| | | | 400 kHz mode | TPBCLK2 * (BRG + 2) | — | μs | — |
| | | | 1 MHz mode (Note 2) | TPBCLK2 * (BRG + 2) | — | μs | — |
| IM20 | TF:SCL | SDAx and SCLx Fall Time | 100 kHz mode | — | 300 | ns | Cb is specified to be from 10 to 400 pF |
| | | | 400 kHz mode | $20 + 0.1 C_b$ | 300 | ns | |
| | | | 1 MHz mode (Note 2) | — | 100 | ns | |

Note 1: BRG is the value of the I²C™ Baud Rate Generator.

Note 2: Maximum pin capacitance = 10 pF for all I2Cx pins (for 1 MHz mode only).

Note 3: The typical value for this parameter is 104 ns.

PIC32MZ Embedded Connectivity with Floating Point Unit (EF) Family

TABLE 37-35: I2Cx BUS DATA TIMING REQUIREMENTS (MASTER MODE) (CONTINUED)

| AC CHARACTERISTICS | | | Standard Operating Conditions: 2.1V to 3.6V (unless otherwise stated) Operating temperature -40°C ≤ TA ≤ +85°C for Industrial -40°C ≤ TA ≤ +125°C for Extended | | | | |
|--------------------|---------|----------------------------|---|---------------------|-------|------------------------------------|---|
| Param. No. | Symbol | Characteristics | Min. ⁽¹⁾ | Max. | Units | Conditions | |
| IM21 | TR:SCL | SDAx and SCLx Rise Time | 100 kHz mode | — | 1000 | ns | Cb is specified to be from 10 to 400 pF |
| | | | 400 kHz mode | 20 + 0.1 Cb | 300 | ns | |
| | | | 1 MHz mode (Note 2) | — | 300 | ns | |
| IM25 | TSU:DAT | Data Input Setup Time | 100 kHz mode | 250 | — | ns | — |
| | | | 400 kHz mode | 100 | — | ns | |
| | | | 1 MHz mode (Note 2) | 100 | — | ns | |
| IM26 | THD:DAT | Data Input Hold Time | 100 kHz mode | 0 | — | µs | — |
| | | | 400 kHz mode | 0 | 0.9 | µs | |
| | | | 1 MHz mode (Note 2) | 0 | 0.3 | µs | |
| IM30 | TSU:STA | Start Condition Setup Time | 100 kHz mode | TPBCLK2 * (BRG + 2) | — | µs | Only relevant for Repeated Start condition |
| | | | 400 kHz mode | TPBCLK2 * (BRG + 2) | — | µs | |
| | | | 1 MHz mode (Note 2) | TPBCLK2 * (BRG + 2) | — | µs | |
| IM31 | THD:STA | Start Condition Hold Time | 100 kHz mode | TPBCLK2 * (BRG + 2) | — | µs | After this period, the first clock pulse is generated |
| | | | 400 kHz mode | TPBCLK2 * (BRG + 2) | — | µs | |
| | | | 1 MHz mode (Note 2) | TPBCLK2 * (BRG + 2) | — | µs | |
| IM33 | TSU:STO | Stop Condition Setup Time | 100 kHz mode | TPBCLK2 * (BRG + 2) | — | µs | — |
| | | | 400 kHz mode | TPBCLK2 * (BRG + 2) | — | µs | |
| | | | 1 MHz mode (Note 2) | TPBCLK2 * (BRG + 2) | — | µs | |
| IM34 | THD:STO | Stop Condition Hold Time | 100 kHz mode | TPBCLK2 * (BRG + 2) | — | ns | — |
| | | | 400 kHz mode | TPBCLK2 * (BRG + 2) | — | ns | |
| | | | 1 MHz mode (Note 2) | TPBCLK2 * (BRG + 2) | — | ns | |
| IM40 | TAA:SCL | Output Valid from Clock | 100 kHz mode | — | 3500 | ns | — |
| | | | 400 kHz mode | — | 1000 | ns | |
| | | | 1 MHz mode (Note 2) | — | 350 | ns | |
| IM45 | TBF:SDA | Bus Free Time | 100 kHz mode | 4.7 | — | µs | The amount of time the bus must be free before a new transmission can start |
| | | | 400 kHz mode | 1.3 | — | µs | |
| | | | 1 MHz mode (Note 2) | 0.5 | — | µs | |
| IM50 | Cb | Bus Capacitive Loading | — | — | pF | See parameter DO58 | |
| IM51 | TPGD | Pulse Gobbler Delay | 52 | 312 | ns | See Note 3 | |

Note 1: BRG is the value of the I²C™ Baud Rate Generator.

2: Maximum pin capacitance = 10 pF for all I2Cx pins (for 1 MHz mode only).

3: The typical value for this parameter is 104 ns.

PIC32MZ Embedded Connectivity with Floating Point Unit (EF) Family

FIGURE 37-18: I2Cx BUS START/STOP BITS TIMING CHARACTERISTICS (SLAVE MODE)

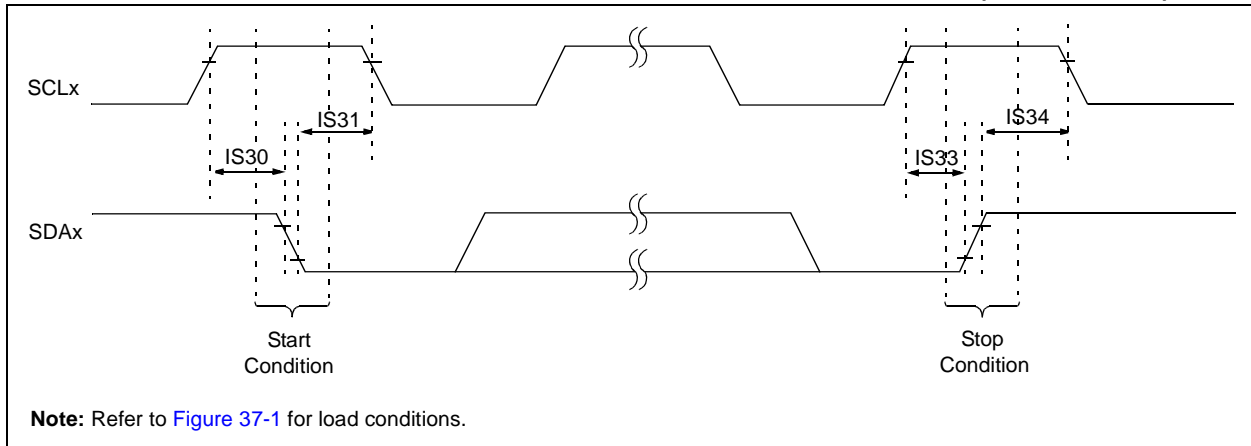

FIGURE 37-19: I2Cx BUS DATA TIMING CHARACTERISTICS (SLAVE MODE)

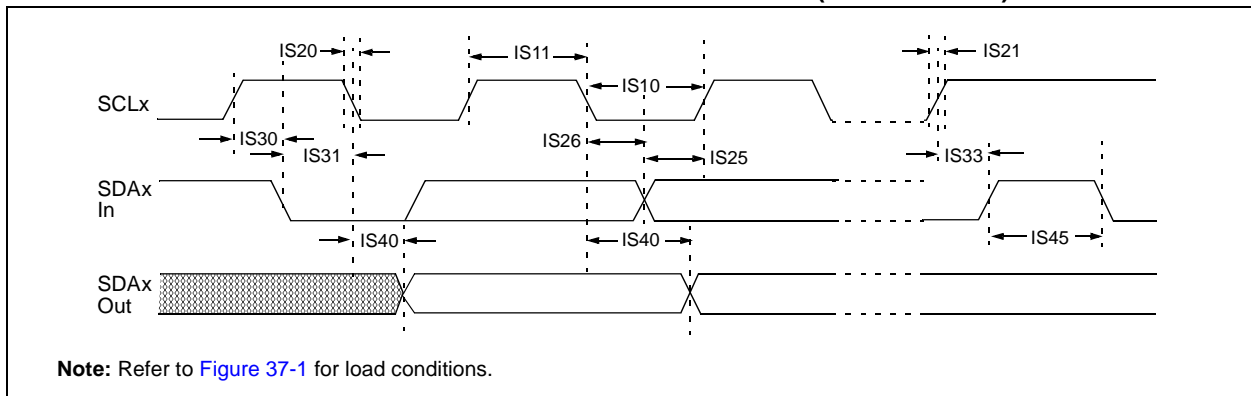

TABLE 37-36: I2Cx BUS DATA TIMING REQUIREMENTS (SLAVE MODE)

| AC CHARACTERISTICS | | | | Standard Operating Conditions: 2.1V to 3.6V (unless otherwise stated) Operating temperature -40°C ≤ Ta ≤ +85°C for Industrial -40°C ≤ Ta ≤ +125°C for Extended | | | |
|--------------------|---------|-----------------|------------------------|---|------|-------|--|
| Param. No. | Symbol | Characteristics | | Min. | Max. | Units | Conditions |
| IS10 | TLO:SCL | Clock Low Time | 100 kHz mode | 4.7 | — | μs | PBCLK must operate at a minimum of 800 kHz |
| | | | 400 kHz mode | 1.3 | — | μs | PBCLK must operate at a minimum of 3.2 MHz |
| | | | 1 MHz mode (Note 1) | 0.5 | — | μs | — |
| IS11 | THI:SCL | Clock High Time | 100 kHz mode | 4.0 | — | μs | PBCLK must operate at a minimum of 800 kHz |
| | | | 400 kHz mode | 0.6 | — | μs | PBCLK must operate at a minimum of 3.2 MHz |
| | | | 1 MHz mode (Note 1) | 0.5 | — | μs | — |

Note 1: Maximum pin capacitance = 10 pF for all I2Cx pins (for 1 MHz mode only).

PIC32MZ Embedded Connectivity with Floating Point Unit (EF) Family

TABLE 37-36: I2Cx BUS DATA TIMING REQUIREMENTS (SLAVE MODE) (CONTINUED)

| AC CHARACTERISTICS | | | | Standard Operating Conditions: 2.1V to 3.6V (unless otherwise stated) Operating temperature -40°C ≤ TA ≤ +85°C for Industrial -40°C ≤ TA ≤ +125°C for Extended | | | |
|--------------------|---------|-------------------------------|------------------------|---|-------|------------------------------------|---|
| Param. No. | Symbol | Characteristics | Min. | Max. | Units | Conditions | |
| IS20 | TF:SCL | SDAx and SCLx Fall Time | 100 kHz mode | — | 300 | ns | CB is specified to be from 10 to 400 pF |
| | | | 400 kHz mode | 20 + 0.1 CB | 300 | ns | |
| | | | 1 MHz mode (Note 1) | — | 100 | ns | |
| IS21 | TR:SCL | SDAx and SCLx Rise Time | 100 kHz mode | — | 1000 | ns | CB is specified to be from 10 to 400 pF |
| | | | 400 kHz mode | 20 + 0.1 CB | 300 | ns | |
| | | | 1 MHz mode (Note 1) | — | 300 | ns | |
| IS25 | TSU:DAT | Data Input Setup Time | 100 kHz mode | 250 | — | ns | — |
| | | | 400 kHz mode | 100 | — | ns | |
| | | | 1 MHz mode (Note 1) | 100 | — | ns | |
| IS26 | THD:DAT | Data Input Hold Time | 100 kHz mode | 0 | — | ns | — |
| | | | 400 kHz mode | 0 | 0.9 | µs | |
| | | | 1 MHz mode (Note 1) | 0 | 0.3 | µs | |
| IS30 | TSU:STA | Start Condition Setup Time | 100 kHz mode | 4700 | — | ns | Only relevant for Repeated Start condition |
| | | | 400 kHz mode | 600 | — | ns | |
| | | | 1 MHz mode (Note 1) | 250 | — | ns | |
| IS31 | THD:STA | Start Condition Hold Time | 100 kHz mode | 4000 | — | ns | After this period, the first clock pulse is generated |
| | | | 400 kHz mode | 600 | — | ns | |
| | | | 1 MHz mode (Note 1) | 250 | — | ns | |
| IS33 | TSU:STO | Stop Condition Setup Time | 100 kHz mode | 4000 | — | ns | — |
| | | | 400 kHz mode | 600 | — | ns | |
| | | | 1 MHz mode (Note 1) | 600 | — | ns | |
| IS34 | THD:STO | Stop Condition Hold Time | 100 kHz mode | 4000 | — | ns | — |
| | | | 400 kHz mode | 600 | — | ns | |
| | | | 1 MHz mode (Note 1) | 250 | — | ns | |
| IS40 | TAA:SCL | Output Valid from Clock | 100 kHz mode | 0 | 3500 | ns | — |
| | | | 400 kHz mode | 0 | 1000 | ns | |
| | | | 1 MHz mode (Note 1) | 0 | 350 | ns | |
| IS45 | TBF:SDA | Bus Free Time | 100 kHz mode | 4.7 | — | µs | The amount of time the bus must be free before a new transmission can start |
| | | | 400 kHz mode | 1.3 | — | µs | |
| | | | 1 MHz mode (Note 1) | 0.5 | — | µs | |
| IS50 | CB | Bus Capacitive Loading | — | — | pF | See parameter DO58 | |

Note 1: Maximum pin capacitance = 10 pF for all I2Cx pins (for 1 MHz mode only).

PIC32MZ Embedded Connectivity with Floating Point Unit (EF) Family

FIGURE 37-20: CANx MODULE I/O TIMING CHARACTERISTICS

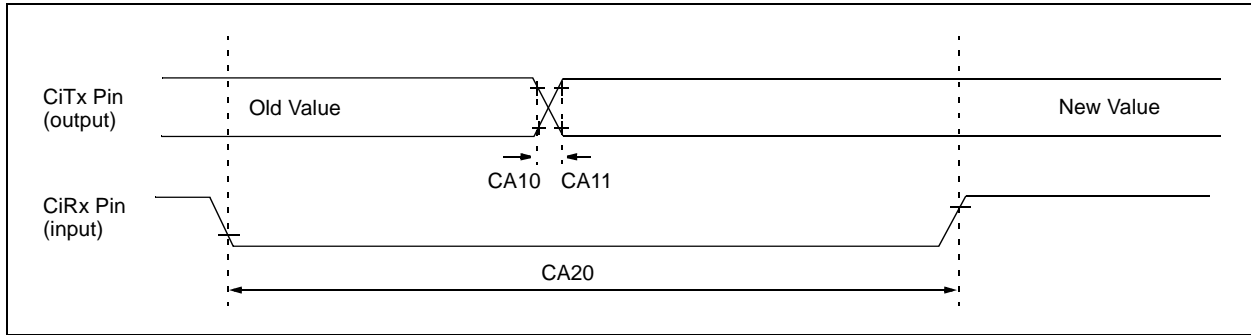

TABLE 37-37: CANx MODULE I/O TIMING REQUIREMENTS

| AC CHARACTERISTICS | | | Standard Operating Conditions: 2.1V to 3.6V (unless otherwise stated) Operating temperature $-40^{\circ}\text{C} \leq T_A \leq +85^{\circ}\text{C}$ for Industrial $-40^{\circ}\text{C} \leq T_A \leq +125^{\circ}\text{C}$ for Extended | | | | |
|--------------------|--------|---|---|--------------------|-----|-------|------------------------------------|
| Param No. | Symbol | Characteristic ⁽¹⁾ | Min | Typ ⁽²⁾ | Max | Units | Conditions |
| CA10 | TioF | Port Output Fall Time | — | — | — | ns | See parameter DO32 |
| CA11 | TioR | Port Output Rise Time | — | — | — | ns | See parameter DO31 |
| CA20 | Tcwf | Pulse Width to Trigger CAN Wake-up Filter | 700 | — | — | ns | — |

Note 1: These parameters are characterized but not tested in manufacturing.

Note 2: Data in "Typ" column is at 3.3V, +25°C unless otherwise stated. Parameters are for design guidance only and are not tested.

PIC32MZ Embedded Connectivity with Floating Point Unit (EF) Family

TABLE 37-38: ADC MODULE SPECIFICATIONS

| AC CHARACTERISTICS | | | Standard Operating Conditions: 2.1V to 3.6V (unless otherwise stated) Operating temperature $-40^{\circ}\text{C} \leq T_A \leq +85^{\circ}\text{C}$ for Industrial $-40^{\circ}\text{C} \leq T_A \leq +125^{\circ}\text{C}$ for Extended | | | | |
|--|-----------|--|---|---------|----------------------------|---------------|---|
| Param. No. | Symbol | Characteristics | Min. | Typ. | Max. | Units | Conditions |
| Device Supply | | | | | | | |
| AD01 | AVDD | Module VDD Supply | Greater of VDD – 0.3 or 2.1 | — | Lesser of VDD + 0.3 or 3.6 | V | — |
| AD02 | AVSS | Module VSS Supply | VSS | — | VSS + 0.3 | V | — |
| Reference Inputs | | | | | | | |
| AD05 | VREFH | Reference Voltage High | VREFL + 1.8 | — | AVDD | V | (Note 1) |
| AD06 | VREFL | Reference Voltage Low | AVSS | — | VREFH – 1.8 | V | (Note 1) |
| AD07 | VREF | Absolute Reference Voltage (VREFH – VREFL) | 1.8 | — | AVDD | V | (Note 2) |
| AD08 | IREF | Current Drain | — | 102 | — | μA | Per ADCx ('x' = 0-4, 7) |
| Analog Input | | | | | | | |
| AD12 | VINH-VINL | Full-Scale Input Span | VREFL | — | VREFH | V | — |
| AD13 | VINL | Absolute VINL Input Voltage | AVSS | — | VREFL | V | — |
| AD14 | VINH | Absolute VINH Input Voltage | AVSS | — | VREFH | V | — |
| ADC Accuracy – Measurements with External VREF+/VREF- | | | | | | | |
| AD20c | Nr | Resolution | 6 | — | 12 | bits | Selectable 6, 8, 10, 12 Resolution Ranges |
| AD21c | INL | Integral Nonlinearity | — | ± 3 | — | LSb | VINL = AVSS = VREFL = 0V, AVDD = VREFH = 3.3V |
| AD22c | DNL | Differential Nonlinearity | — | ± 1 | — | LSb | VINL = AVSS = VREFL = 0V, AVDD = VREFH = 3.3V |
| AD23c | GERR | Gain Error | — | ± 8 | — | LSb | VINL = AVSS = VREFL = 0V, AVDD = VREFH = 3.3V |
| AD24c | EOFF | Offset Error | — | ± 2 | — | LSb | VINL = AVSS = 0V, AVDD = 3.3V |
| Dynamic Performance | | | | | | | |
| AD31b | SINAD | Signal to Noise and Distortion | — | 67 | — | dB | Single-ended (Notes 2,3) |
| AD34b | ENOB | Effective Number of bits | — | 10.5 | — | bits | (Notes 2,3) |

- Note 1:** These parameters are not characterized or tested in manufacturing.
Note 2: These parameters are characterized, but not tested in manufacturing.
Note 3: Characterized with a 1 kHz sine wave.
Note 4: The ADC module is functional at $V_{BORMIN} < V_{DD} < V_{DDMIN}$, but with degraded performance. Unless otherwise stated, module functionality is guaranteed, but not characterized.

PIC32MZ Embedded Connectivity with Floating Point Unit (EF) Family

TABLE 37-39: ANALOG-TO-DIGITAL CONVERSION TIMING REQUIREMENTS

| AC CHARACTERISTICS ⁽²⁾ | | | Standard Operating Conditions: 2.1V to 3.6V (unless otherwise stated) Operating temperature -40°C ≤ TA ≤ +85°C for Industrial -40°C ≤ TA ≤ +125°C for Extended | | | | |
|---|---|---|---|---------------------|--|---|--|
| Param. No. | Symbol | Characteristics | Min. | Typ. ⁽¹⁾ | Max. | Units | Conditions |
| Clock Parameters | | | | | | | |
| AD50 | TAD | ADC Clock Period | 20 | — | 6250 | ns | — |
| Throughput Rate | | | | | | | |
| AD51 | FTP | Sample Rate for ADC0-ADC4 (Class 1 Inputs) | — | — | 3.125 | Msp | 12-bit resolution Source Impedance ≤ 200Ω |
| | | | — | — | 3.57 | Msp | 10-bit resolution Source Impedance ≤ 200Ω |
| | | | — | — | 4.16 | Msp | 8-bit resolution Source Impedance ≤ 200Ω |
| | | | — | — | 5 | Msp | 6-bit resolution Source Impedance ≤ 200Ω |
| | Sample Rate for ADC7 (Class 2 and Class 3 Inputs) | — | — | 2.94 | Msp | 12-bit resolution Source Impedance ≤ 200Ω | |
| | | — | — | 3.33 | Msp | 10-bit resolution Source Impedance ≤ 200Ω | |
| | | | — | — | 3.84 | Msp | 8-bit resolution Source Impedance ≤ 200Ω |
| | | | — | — | 4.55 | Msp | 6-bit resolution Source Impedance ≤ 200Ω |
| Timing Parameters | | | | | | | |
| AD60 | TSAMP | Sample Time for ADC0-ADC4 (Class 1 Inputs) | 3 | — | — | TAD | Source Impedance ≤ 200Ω, Max ADC clock Source Impedance ≤ 500Ω, Max ADC clock Source Impedance ≤ 1 KΩ, Max ADC clock Source Impedance ≤ 5 KΩ, Max ADC clock |
| | | | 4 | — | — | | |
| | | | 5 | | | | |
| 13 | | | | | | | |
| Sample Time for ADC7 (Class 2 and 3 Inputs) | 4 | — | — | TAD | Source Impedance ≤ 200Ω, Max ADC clock Source Impedance ≤ 500Ω, Max ADC clock Source Impedance ≤ 1 KΩ, Max ADC clock Source Impedance ≤ 5 KΩ, Max ADC clock | | |
| | 5 | | | | | | |
| | 6 | | | | | | |
| Sample Time for ADC7 (Class 2 and 3 Inputs) | 14 | See Table 37-40 | — | — | TAD | CVDEN (ADCCON1<11>) = 1 | |
| | — | | | | | | |
| AD62 | TCONV | Conversion Time (after sample time is complete) | — | — | 13 | TAD | 12-bit resolution |
| | | | — | — | 11 | | 10-bit resolution |
| | | | — | — | 9 | | 8-bit resolution |
| | | | — | — | 7 | | 6-bit resolution |
| AD65 | TWAKE | Wake-up time from Low-Power Mode | — | 500 | — | TAD | Lesser of 500 TAD or 20 μs. |
| | | | — | 20 | — | μs | |

Note 1: These parameters are characterized, but not tested in manufacturing.

Note 2: The ADC module is functional at VBORMIN < VDD < VDDMIN, but with degraded performance. Unless otherwise stated, module functionality is guaranteed, but not characterized.

PIC32MZ Embedded Connectivity with Floating Point Unit (EF) Family

TABLE 37-40: ADC SAMPLE TIMES WITH CVD ENABLED

| AC CHARACTERISTICS ⁽²⁾ | | | Standard Operating Conditions: 2.1V to 3.6V (unless otherwise stated) Operating temperature -40°C ≤ TA ≤ +85°C for Industrial -40°C ≤ TA ≤ +125°C for Extended | | | | |
|-----------------------------------|--------|--|---|---|------|-----------------|---|
| Param. No. | Symbol | Characteristics | Min. | Typ. ⁽¹⁾ | Max. | Units | Conditions |
| AD60a | TSAMP | Sample Time for ADC7 (Class 2 and Class 3 Inputs) with the CVDEN bit (ADCCON1<11>) = 1 | 8 | — | — | T _{AD} | Source Impedance ≤ 200Ω CVDCPL<2:0> (ADCCON2<28:26>) = 001 CVDCPL<2:0> (ADCCON2<28:26>) = 010 CVDCPL<2:0> (ADCCON2<28:26>) = 011 CVDCPL<2:0> (ADCCON2<28:26>) = 100 CVDCPL<2:0> (ADCCON2<28:26>) = 101 CVDCPL<2:0> (ADCCON2<28:26>) = 110 CVDCPL<2:0> (ADCCON2<28:26>) = 111 |
| | | | 9 | | | | |
| | | | 11 | | | | |
| | | | 12 | | | | |
| | | | 14 | | | | |
| | | | 16 | | | | |
| | | | 17 | | | | |
| | | | 17 | | | | |
| | | | 10 | — | — | T _{AD} | Source Impedance ≤ 500Ω CVDCPL<2:0> (ADCCON2<28:26>) = 001 CVDCPL<2:0> (ADCCON2<28:26>) = 010 CVDCPL<2:0> (ADCCON2<28:26>) = 011 CVDCPL<2:0> (ADCCON2<28:26>) = 100 CVDCPL<2:0> (ADCCON2<28:26>) = 101 CVDCPL<2:0> (ADCCON2<28:26>) = 110 CVDCPL<2:0> (ADCCON2<28:26>) = 111 |
| | | | 12 | | | | |
| | | | 14 | | | | |
| | | | 16 | | | | |
| | | | 18 | | | | |
| | | | 19 | | | | |
| | | | 21 | | | | |
| | | | 13 | — | — | T _{AD} | Source Impedance ≤ 1 KΩ CVDCPL<2:0> (ADCCON2<28:26>) = 001 CVDCPL<2:0> (ADCCON2<28:26>) = 010 CVDCPL<2:0> (ADCCON2<28:26>) = 011 CVDCPL<2:0> (ADCCON2<28:26>) = 100 CVDCPL<2:0> (ADCCON2<28:26>) = 101 CVDCPL<2:0> (ADCCON2<28:26>) = 110 CVDCPL<2:0> (ADCCON2<28:26>) = 111 |
| 16 | | | | | | | |
| 18 | | | | | | | |
| 21 | | | | | | | |
| 23 | | | | | | | |
| 26 | | | | | | | |
| 28 | | | | | | | |
| 41 | — | — | T _{AD} | Source Impedance ≤ 5 KΩ CVDCPL<2:0> (ADCCON2<28:26>) = 001 CVDCPL<2:0> (ADCCON2<28:26>) = 010 CVDCPL<2:0> (ADCCON2<28:26>) = 011 CVDCPL<2:0> (ADCCON2<28:26>) = 100 CVDCPL<2:0> (ADCCON2<28:26>) = 101 CVDCPL<2:0> (ADCCON2<28:26>) = 110 CVDCPL<2:0> (ADCCON2<28:26>) = 111 | | | |
| 48 | | | | | | | |
| 56 | | | | | | | |
| 63 | | | | | | | |
| 70 | | | | | | | |
| 78 | | | | | | | |
| 85 | | | | | | | |

Note 1: These parameters are characterized, but not tested in manufacturing.

Note 2: The ADC module is functional at VBORMIN < VDD < VDDMIN, but with degraded performance. Unless otherwise stated, module functionality is guaranteed, but not characterized.

PIC32MZ Embedded Connectivity with Floating Point Unit (EF) Family

TABLE 37-41: TEMPERATURE SENSOR SPECIFICATIONS

| AC CHARACTERISTICS | | | Standard Operating Conditions (see Note 1): 2.1V to 3.6V (unless otherwise stated) Operating temperature -40°C ≤ TA ≤ +85°C for Industrial -40°C ≤ TA ≤ +125°C for Extended | | | | |
|--------------------|--------|---------------------|--|---------|------|-------|---------------|
| Param. No. | Symbol | Characteristics | Min. | Typical | Max. | Units | Conditions |
| TS10 | VTS | Rate of Change | — | -5 | — | mV/°C | — |
| TS11 | TR | Resolution | -2 | — | +2 | °C | — |
| TS12 | IVTEMP | Voltage Range | 0.2 | — | 1.2 | V | — |
| TS13 | TMIN | Minimum Temperature | — | -40 | — | °C | IVTEMP = 1.2V |
| TS14 | TMAX | Maximum Temperature | — | 160 | — | °C | IVTEMP = 0.2V |

Note 1: The temperature sensor is functional at VBORMIN < VDD < VDDMIN, but with degraded performance. Unless otherwise stated, module functionality is tested, but not characterized.

PIC32MZ Embedded Connectivity with Floating Point Unit (EF) Family

FIGURE 37-21: PARALLEL SLAVE PORT TIMING

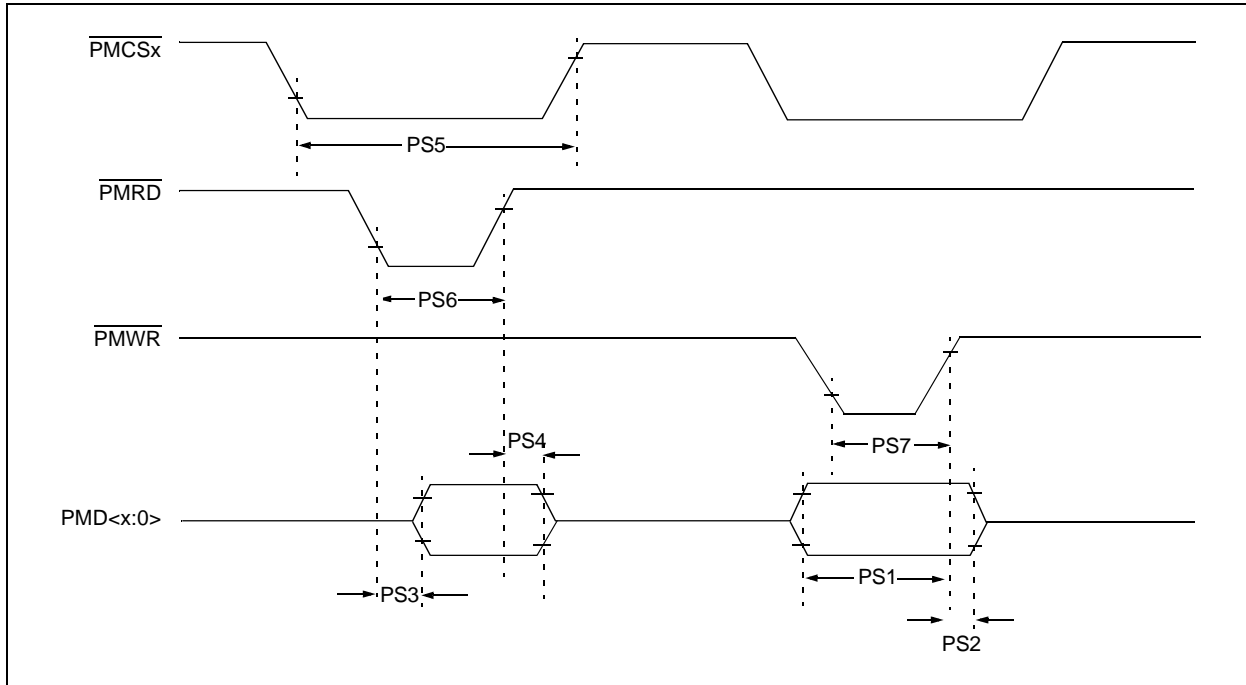

TABLE 37-42: PARALLEL SLAVE PORT REQUIREMENTS

| AC CHARACTERISTICS | | | Standard Operating Conditions: 2.1V to 3.6V (unless otherwise stated) Operating temperature $-40^{\circ}\text{C} \leq T_A \leq +85^{\circ}\text{C}$ for Industrial $-40^{\circ}\text{C} \leq T_A \leq +125^{\circ}\text{C}$ for Extended | | | | |
|--------------------|----------|--|---|------|------|-------|------------|
| Param. No. | Symbol | Characteristics ⁽¹⁾ | Min. | Typ. | Max. | Units | Conditions |
| PS1 | TdtV2wrH | Data In Valid before $\overline{\text{PMWR}}$ or $\overline{\text{PMCSx}}$ Inactive (setup time) | 20 | — | — | ns | — |
| PS2 | TwrH2dtI | $\overline{\text{PMWR}}$ or $\overline{\text{PMCSx}}$ Inactive to Data-in Invalid (hold time) | 40 | — | — | ns | — |
| PS3 | TrdL2dtV | $\overline{\text{PMRD}}$ and $\overline{\text{PMCSx}}$ Active to Data-out Valid | — | — | 60 | ns | — |
| PS4 | TrdH2dtI | $\overline{\text{PMRD}}$ Active or $\overline{\text{PMCSx}}$ Inactive to Data-out Invalid | 0 | — | 10 | ns | — |
| PS5 | Tcs | $\overline{\text{PMCSx}}$ Active Time | $T_{\text{PBCLK2}} + 40$ | — | — | ns | — |
| PS6 | TWR | $\overline{\text{PMWR}}$ Active Time | $T_{\text{PBCLK2}} + 25$ | — | — | ns | — |
| PS7 | TRD | $\overline{\text{PMRD}}$ Active Time | $T_{\text{PBCLK2}} + 25$ | — | — | ns | — |

Note 1: These parameters are characterized, but not tested in manufacturing.

PIC32MZ Embedded Connectivity with Floating Point Unit (EF) Family

FIGURE 37-22: PARALLEL MASTER PORT READ TIMING DIAGRAM

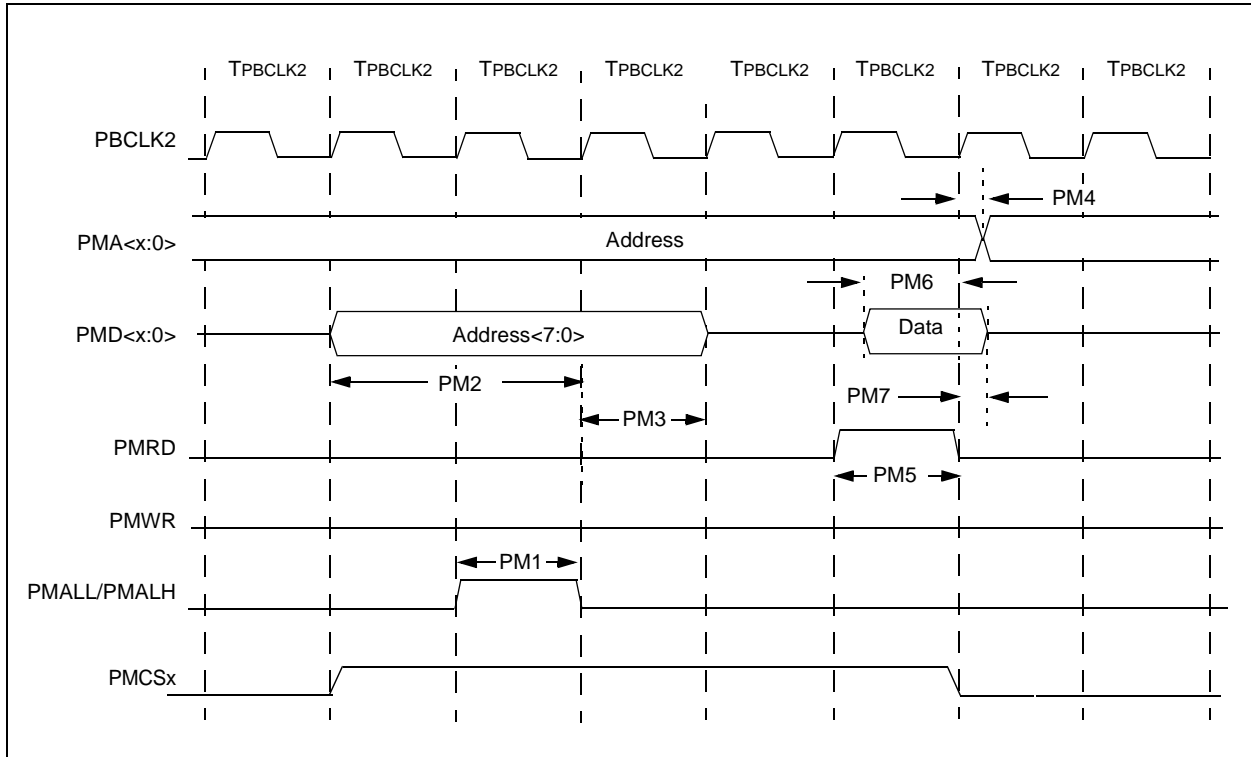

TABLE 37-43: PARALLEL MASTER PORT READ TIMING REQUIREMENTS

| AC CHARACTERISTICS | | | Standard Operating Conditions: 2.1V to 3.6V (unless otherwise stated) Operating temperature -40°C ≤ TA ≤ +85°C for Industrial -40°C ≤ TA ≤ +125°C for Extended | | | | |
|--------------------|---------|--|---|-----------|------|-------|------------|
| Param. No. | Symbol | Characteristics ⁽¹⁾ | Min. | Typ. | Max. | Units | Conditions |
| PM1 | TLAT | PMALL/PMALH Pulse Width | — | 1 TPBCLK2 | — | — | — |
| PM2 | TADSU | Address Out Valid to PMALL/PMALH Invalid (address setup time) | — | 2 TPBCLK2 | — | — | — |
| PM3 | TADHOLD | PMALL/PMALH Invalid to Address Out Invalid (address hold time) | — | 1 TPBCLK2 | — | — | — |
| PM4 | TAHOLD | PMRD Inactive to Address Out Invalid (address hold time) | 5 | — | — | ns | — |
| PM5 | TRD | PMRD Pulse Width | — | 1 TPBCLK2 | — | — | — |
| PM6 | TDSU | PMRD or PMENB Active to Data In Valid (data setup time) | 15 | — | — | ns | — |
| PM7 | TDHOLD | PMRD or PMENB Inactive to Data In Invalid (data hold time) | — | 80 | — | ns | — |

Note 1: These parameters are characterized, but not tested in manufacturing.

PIC32MZ Embedded Connectivity with Floating Point Unit (EF) Family

FIGURE 37-23: PARALLEL MASTER PORT WRITE TIMING DIAGRAM

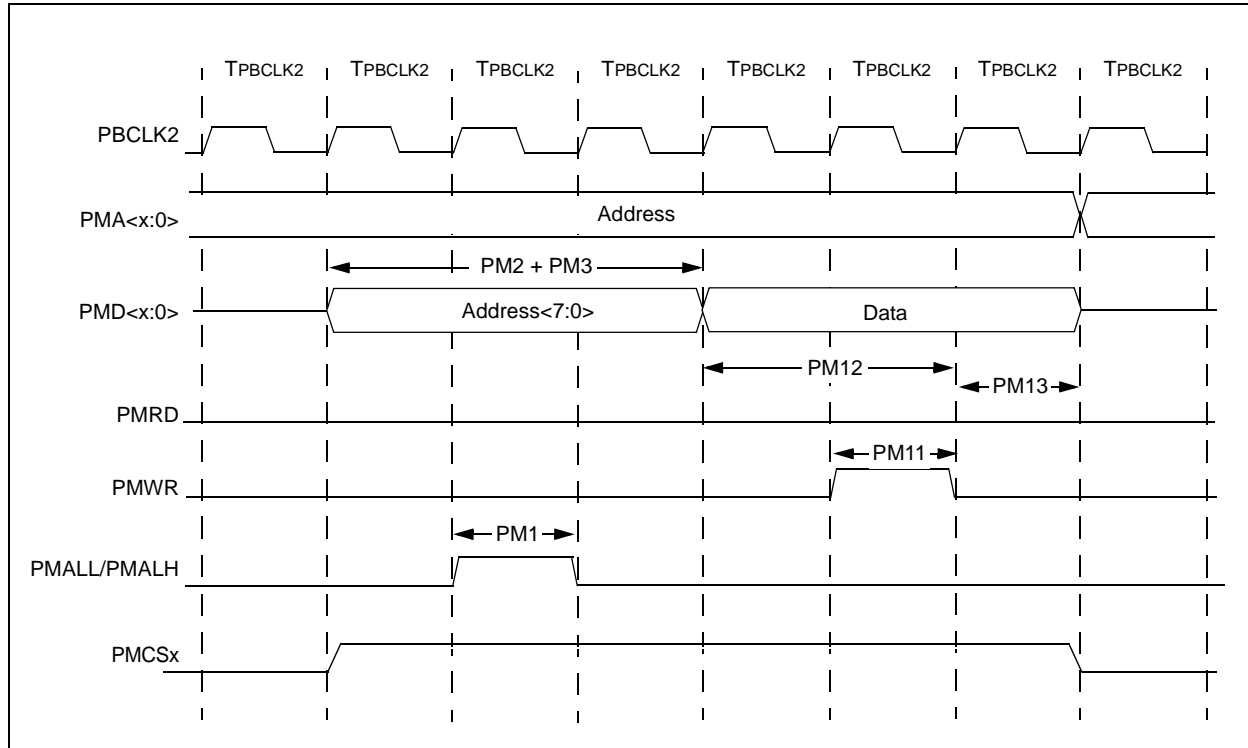

TABLE 37-44: PARALLEL MASTER PORT WRITE TIMING REQUIREMENTS

| AC CHARACTERISTICS | | | Standard Operating Conditions: 2.1V to 3.6V (unless otherwise stated) Operating temperature $-40^{\circ}\text{C} \leq T_A \leq +85^{\circ}\text{C}$ for Industrial $-40^{\circ}\text{C} \leq T_A \leq +125^{\circ}\text{C}$ for Extended | | | | |
|--------------------|--------|---|---|-----------|------|-------|------------|
| Param. No. | Symbol | Characteristics ⁽¹⁾ | Min. | Typ. | Max. | Units | Conditions |
| PM11 | TWR | PMWR Pulse Width | — | 1 TPBCLK2 | — | — | — |
| PM12 | Tdvsu | Data Out Valid before PMWR or PMENB goes Inactive (data setup time) | — | 2 TPBCLK2 | — | — | — |
| PM13 | Tdvhld | PMWR or PMEMB Invalid to Data Out Invalid (data hold time) | — | 1 TPBCLK2 | — | — | — |

Note 1: These parameters are characterized, but not tested in manufacturing.

PIC32MZ Embedded Connectivity with Floating Point Unit (EF) Family

TABLE 37-45: USB OTG ELECTRICAL SPECIFICATIONS

| AC CHARACTERISTICS | | | Standard Operating Conditions: 2.1V to 3.6V (unless otherwise stated) Operating temperature -40°C ≤ TA ≤ +85°C for Industrial -40°C ≤ TA ≤ +125°C for Extended | | | | |
|---------------------------------------|---------|-----------------------------------|---|------|------|-------|--|
| Param. No. | Symbol | Characteristics ⁽¹⁾ | Min. | Typ. | Max. | Units | Conditions |
| USB313 | VUSB3V3 | USB Voltage | 3.0 | — | 3.6 | V | Voltage on VUSB3V3 must be in this range for proper USB operation |
| Low-Speed and Full-Speed Modes | | | | | | | |
| USB315 | VILUSB | Input Low Voltage for USB Buffer | — | — | 0.8 | V | — |
| USB316 | VIHUSB | Input High Voltage for USB Buffer | 2.0 | — | — | V | — |
| USB318 | VDIFS | Differential Input Sensitivity | 0.2 | — | — | V | The difference between D+ and D- must exceed this value while VCM is met |
| USB319 | VCM | Differential Common Mode Range | 0.8 | — | 2.5 | V | — |
| USB321 | VoL | Voltage Output Low | 0.0 | — | 0.3 | V | 1.425 kΩ load connected to VUSB3V3 |
| USB322 | VoH | Voltage Output High | 2.8 | — | 3.6 | V | 14.25 kΩ load connected to ground |
| Hi-Speed Mode | | | | | | | |
| USB323 | VHSDI | Differential input signal level | 150 | — | — | mV | — |
| USB324 | VHSSQ | SQ detection threshold | 100 | — | 150 | mV | — |
| USB325 | VHSCM | Common mode voltage range | -50 | — | 500 | mV | — |
| USB326 | VHSOH | Data signaling high | 360 | — | 440 | mV | — |
| USB327 | VHSOL | Data signaling low | -10 | — | 10 | mV | — |
| USB328 | VCHIRPJ | Chirp J level | 700 | — | 1100 | mV | — |
| USB329 | VCHIRPK | Chirp K level | -900 | — | -500 | mV | — |
| USB330 | ZHSDRV | Driver output resistance | — | 45 | — | Ω | — |

Note 1: These parameters are characterized, but not tested in manufacturing.

PIC32MZ Embedded Connectivity with Floating Point Unit (EF) Family

TABLE 37-46: ETHERNET MODULE SPECIFICATIONS

| AC CHARACTERISTICS | | Standard Operating Conditions: 2.1V to 3.6V (unless otherwise stated) Operating temperature -40°C ≤ TA ≤ +85°C for Industrial -40°C ≤ TA ≤ +125°C for Extended | | | | |
|---------------------------------|-------------------------------------|---|---------|------|-------|----------------------------------|
| Param. No. | Characteristic | Min. | Typical | Max. | Units | Conditions |
| MIIM Timing Requirements | | | | | | |
| ET1 | MDC Duty Cycle | 40 | — | 60 | % | — |
| ET2 | MDC Period | 400 | — | — | ns | — |
| ET3 | MDIO Output Setup and Hold | 10 | — | 10 | ns | See Figure 37-24 |
| ET4 | MDIO Input Setup and Hold | 0 | — | 300 | ns | See Figure 37-25 |
| MII Timing Requirements | | | | | | |
| ET5 | TX Clock Frequency | — | 25 | — | MHz | — |
| ET6 | TX Clock Duty Cycle | 35 | — | 65 | % | — |
| ET7 | ETXDx, ETEN, ETXERR Output Delay | 0 | — | 25 | ns | See Figure 37-26 |
| ET8 | RX Clock Frequency | — | 25 | — | MHz | — |
| ET9 | RX Clock Duty Cycle | 35 | — | 65 | % | — |
| ET10 | ERXDx, ERXDV, ERXERR Setup and Hold | 10 | — | 30 | ns | See Figure 37-27 |
| RMII Timing Requirements | | | | | | |
| ET11 | Reference Clock Frequency | — | 50 | — | MHz | — |
| ET12 | Reference Clock Duty Cycle | 35 | — | 65 | % | — |
| ET13 | ETXDx, ETEN, Setup and Hold | 2 | — | 4 | ns | — |
| ET14 | ERXDx, ERXDV, ERXERR Setup and Hold | 2 | — | 4 | ns | — |

FIGURE 37-24: MDIO SOURCED BY THE PIC32 DEVICE

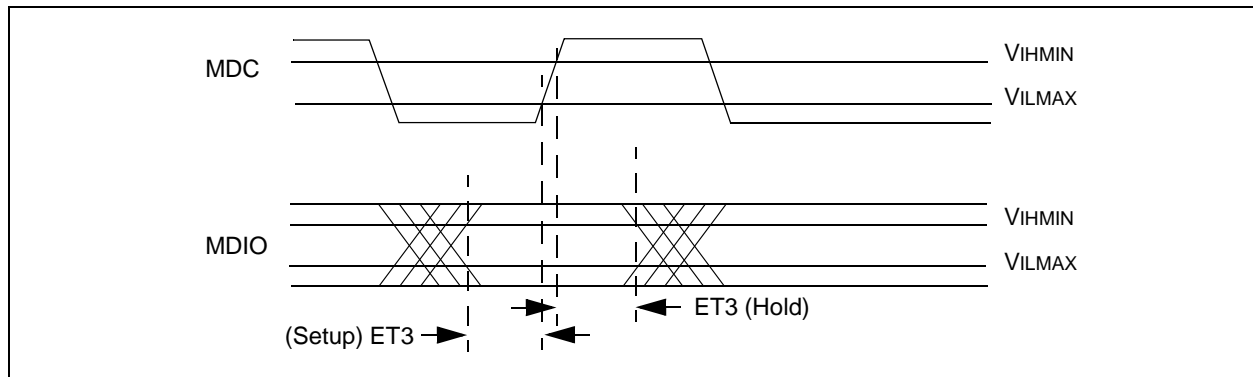
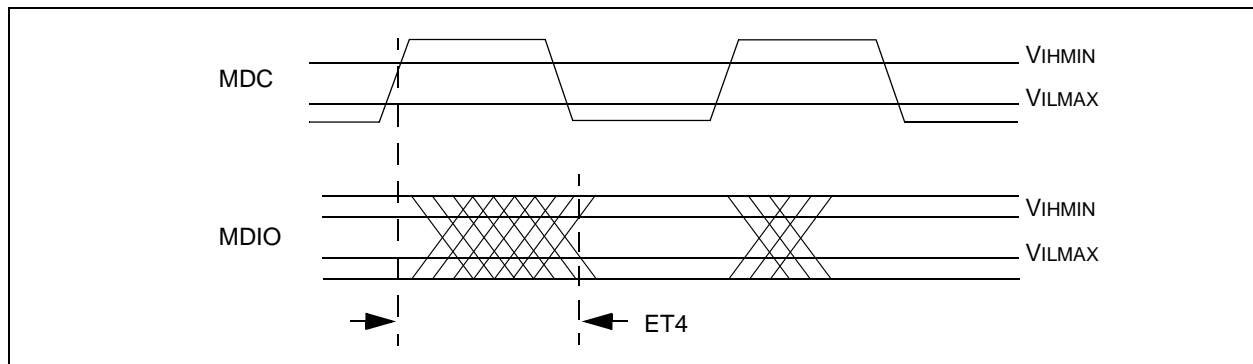

FIGURE 37-25: MDIO SOURCED BY THE PHY



PIC32MZ Embedded Connectivity with Floating Point Unit (EF) Family

FIGURE 37-26: TRANSMIT SIGNAL TIMING RELATIONSHIPS AT THE MII

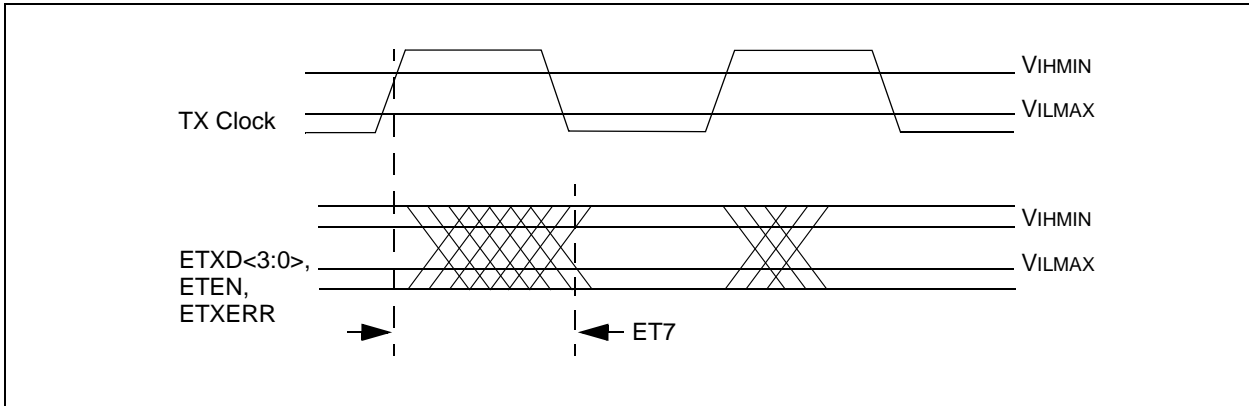

FIGURE 37-27: RECEIVE SIGNAL TIMING RELATIONSHIPS AT THE MII

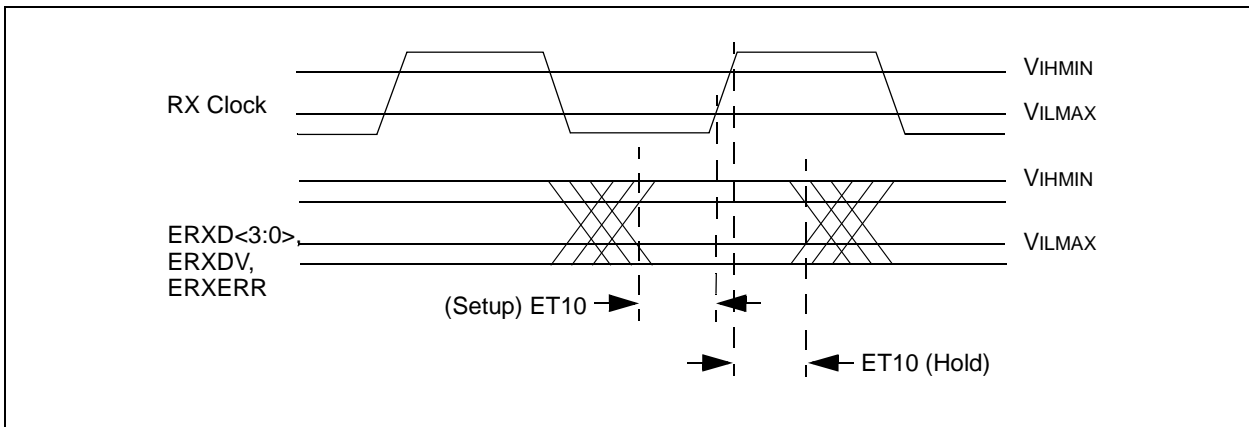

FIGURE 37-28: EBI PAGE READ TIMING

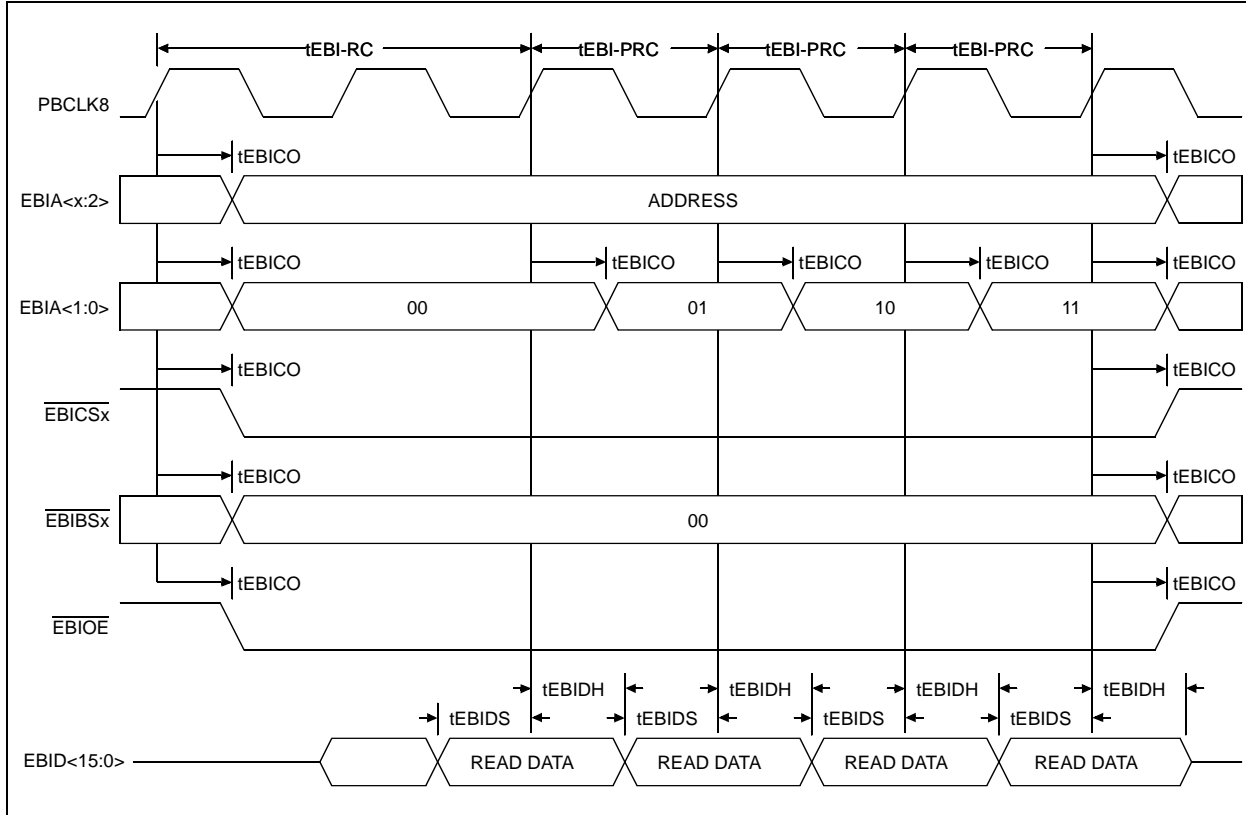
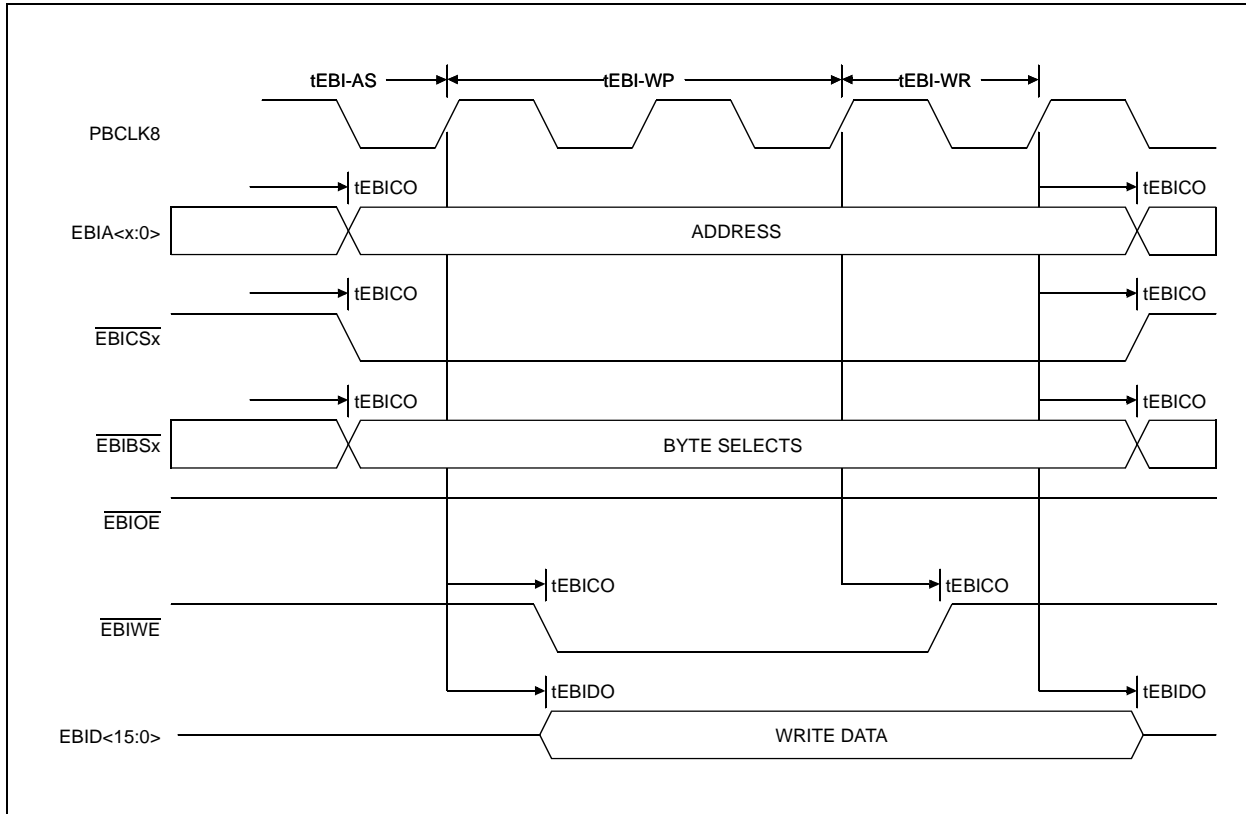

FIGURE 37-29: EBI WRITE TIMING



PIC32MZ Embedded Connectivity with Floating Point Unit (EF) Family

TABLE 37-47: EBI TIMING REQUIREMENTS

| AC CHARACTERISTICS | | | Standard Operating Conditions: 2.1V to 3.6V (unless otherwise stated) Operating temperature $-40^{\circ}\text{C} \leq T_A \leq +85^{\circ}\text{C}$ for Industrial $-40^{\circ}\text{C} \leq T_A \leq +125^{\circ}\text{C}$ for Extended | | | | |
|--------------------|---------|--------------------------------------|---|------|------|-------|----------------------|
| Param. No. | Symbol | Characteristic | Min. | Typ. | Max. | Units | Conditions |
| EB10 | TEBICK | Internal EBI Clock Period (PBCLK8) | 10 | — | — | ns | — |
| EB11 | TEBIRC | EBI Read Cycle Time (TRC<5:0>) | 20 | — | — | ns | — |
| EB12 | TEBIPRC | EBI Page Read Cycle Time (TPRC<3:0>) | 20 | — | — | ns | — |
| EB13 | TEBIAS | EBI Write Address Setup (TAS<1:0>) | 10 | — | — | ns | — |
| EB14 | TEBIWP | EBI Write Pulse Width (TWP<5:0>) | 10 | — | — | ns | — |
| EB15 | TEBIWR | EBI Write Recovery Time (TWR<1:0>) | 10 | — | — | ns | — |
| EB16 | TEBICO | EBI Output Control Signal Delay | — | — | 5 | ns | See Note 1 |
| EB17 | TEBIDO | EBI Output Data Signal Delay | — | — | 5 | ns | See Note 1 |
| EB18 | TEBIDS | EBI Input Data Setup | 5 | — | — | ns | See Note 1 |
| EB19 | TEBIDH | EBI Input Data Hold | 3 | — | — | ns | See Note 1, 2 |

Note 1: Maximum pin capacitance = 10 pF.

2: Hold time from EBI Address change is 0 ns.

TABLE 37-48: EBI THROUGHPUT REQUIREMENTS

| AC CHARACTERISTICS | | Standard Operating Conditions: 2.1V to 3.6V (unless otherwise stated) Operating temperature $-40^{\circ}\text{C} \leq T_A \leq +85^{\circ}\text{C}$ for Industrial $-40^{\circ}\text{C} \leq T_A \leq +125^{\circ}\text{C}$ for Extended | | | | |
|--------------------|-------------------------|---|------|------|-------|------------|
| Param. No. | Characteristic | Min. | Typ. | Max. | Units | Conditions |
| EB20 | Asynchronous SRAM Read | — | 100 | — | Mbps | — |
| EB21 | Asynchronous SRAM Write | — | 533 | — | Mbps | — |

Note 1: Maximum pin capacitance = 10 pF.

2: Hold time from EBI Address change is 0 ns.

PIC32MZ Embedded Connectivity with Floating Point Unit (EF) Family

FIGURE 37-30: EJTAG TIMING CHARACTERISTICS

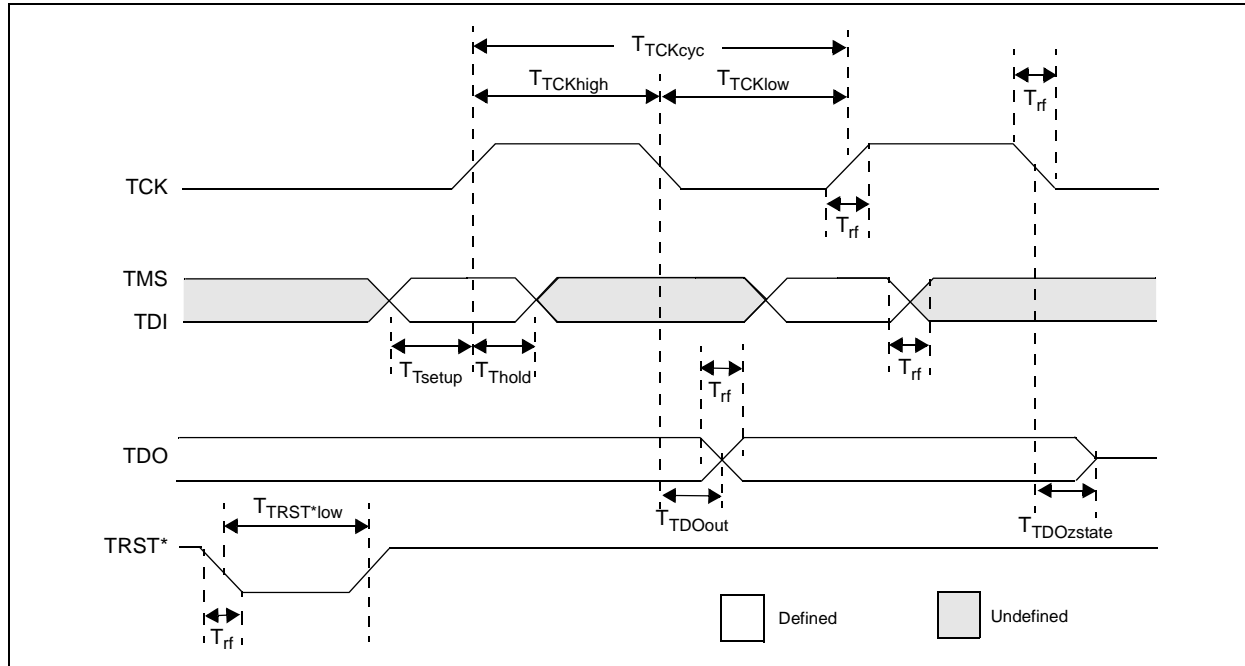

TABLE 37-49: EJTAG TIMING REQUIREMENTS

| AC CHARACTERISTICS | | | Standard Operating Conditions: 2.1V to 3.6V (unless otherwise stated) Operating temperature $-40^{\circ}\text{C} \leq T_A \leq +85^{\circ}\text{C}$ for Industrial $-40^{\circ}\text{C} \leq T_A \leq +125^{\circ}\text{C}$ for Extended | | | |
|--------------------|------------|--|---|------|-------|------------|
| Param. No. | Symbol | Description ⁽¹⁾ | Min. | Max. | Units | Conditions |
| EJ1 | TTCKCYC | TCK Cycle Time | 25 | — | ns | — |
| EJ2 | TTCKHIGH | TCK High Time | 10 | — | ns | — |
| EJ3 | TTCKLOW | TCK Low Time | 10 | — | ns | — |
| EJ4 | TTSETUP | TAP Signals Setup Time Before Rising TCK | 5 | — | ns | — |
| EJ5 | TTHOLD | TAP Signals Hold Time After Rising TCK | 3 | — | ns | — |
| EJ6 | TTDOOUT | TDO Output Delay Time from Falling TCK | — | 5 | ns | — |
| EJ7 | TTDOZSTATE | TDO 3-State Delay Time from Falling TCK | — | 5 | ns | — |
| EJ8 | TTRSTLOW | TRST Low Time | 25 | — | ns | — |
| EJ9 | TRF | TAP Signals Rise/Fall Time, All Input and Output | — | — | ns | — |

Note 1: These parameters are characterized, but not tested in manufacturing.

38.0 AC AND DC CHARACTERISTICS GRAPHS

Note: The graphs provided are a statistical summary based on a limited number of samples and are provided for design guidance purposes only. The performance characteristics listed herein are not tested or guaranteed. In some graphs, the data presented may be outside the specified operating range (e.g., outside specified power supply range) and therefore, outside the warranted range.

FIGURE 38-1: V_{OH} – 4x DRIVER PINS

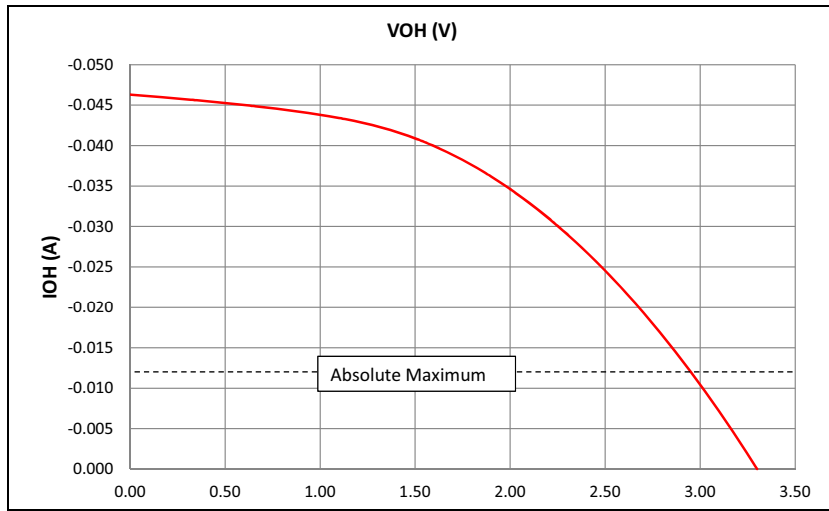

FIGURE 38-3: V_{OH} – 8x DRIVER PINS

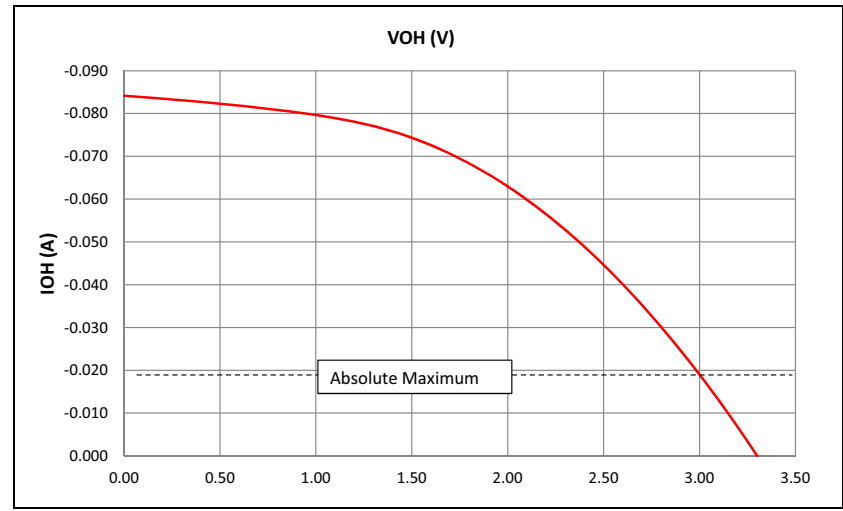

FIGURE 38-2: V_{OL} – 4x DRIVER PINS

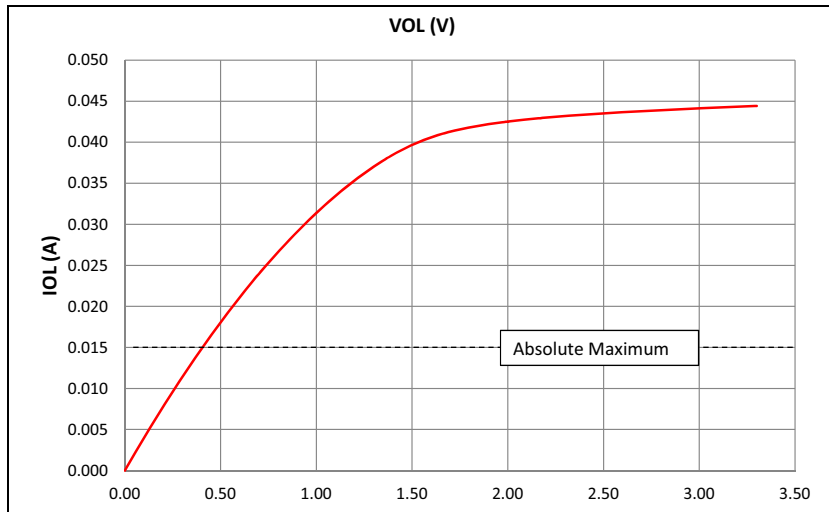

FIGURE 38-4: V_{OL} – 8x DRIVER PINS

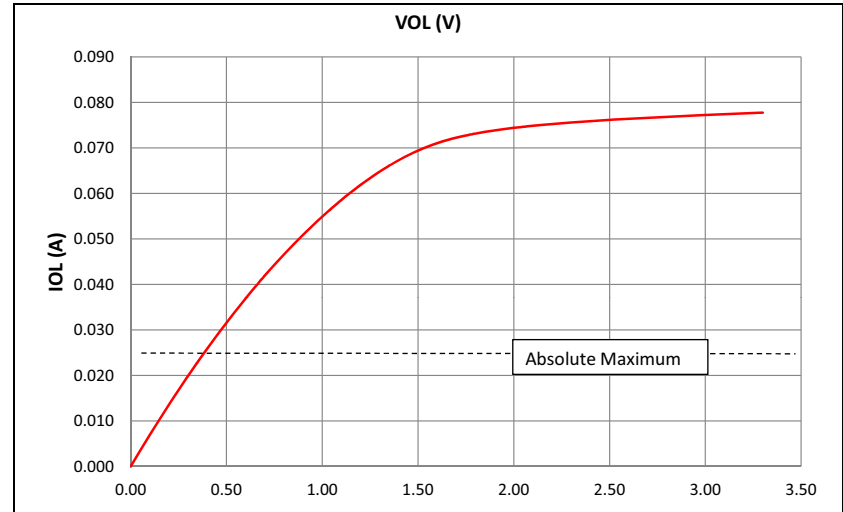

FIGURE 38-5: V_{OH} – 12x DRIVER PINS

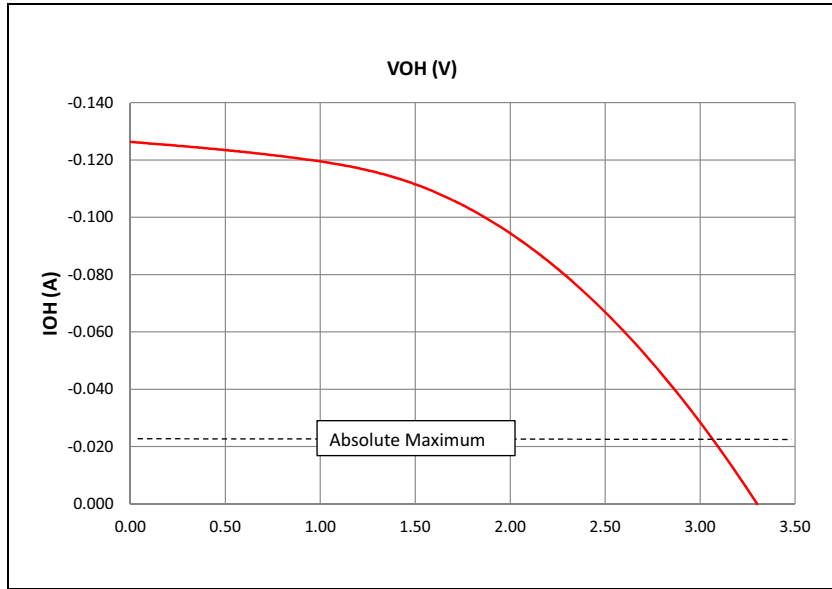

FIGURE 38-7: TYPICAL TEMPERATURE SENSOR VOLTAGE

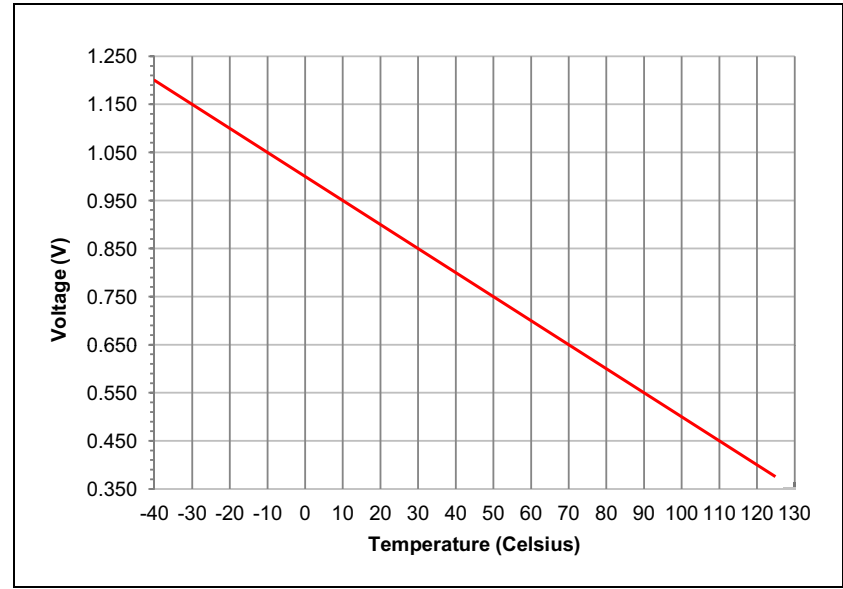
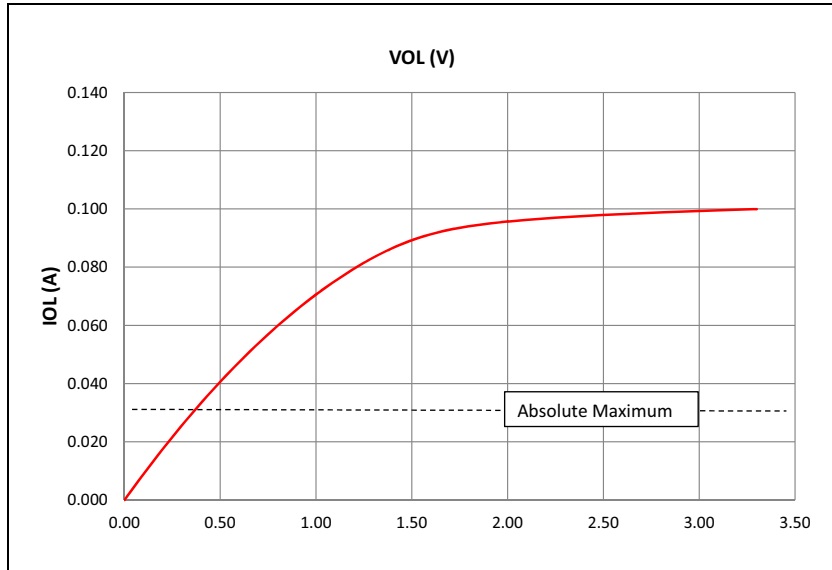

FIGURE 38-6: V_{OL} – 12x DRIVER PINS



PIC32MZ Embedded Connectivity with Floating Point Unit (EF) Family

39.0 PACKAGING INFORMATION

39.1 Package Marking Information

64-Lead QFN (9x9x0.9 mm)

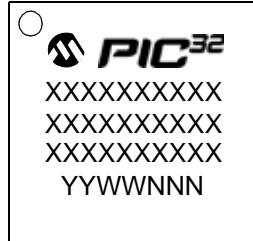

Example

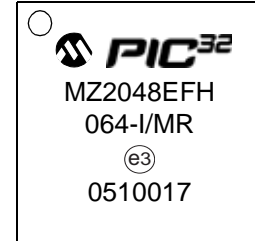

64-Lead TQFP (10x10x1 mm)

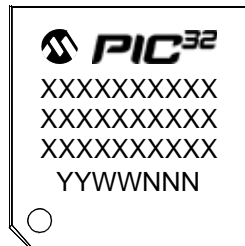

Example

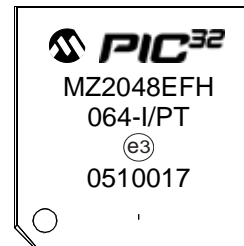

100-Lead TQFP (14x14x1 mm)

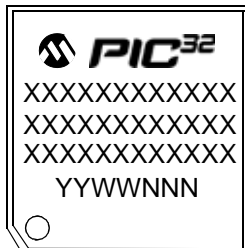

Example

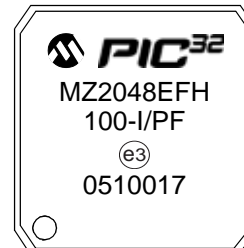

| | | |
|----------------|--------|--|
| Legend: | XX...X | Customer-specific information |
| | Y | Year code (last digit of calendar year) |
| | YY | Year code (last 2 digits of calendar year) |
| | WW | Week code (week of January 1 is week '01') |
| | NNN | Alphanumeric traceability code |
| | * | Pb-free JEDEC designator for Matte Tin (Sn) |
| | | This package is Pb-free. The Pb-free JEDEC designator (e3) can be found on the outer packaging for this package. |

Note: In the event the full Microchip part number cannot be marked on one line, it will be carried over to the next line, thus limiting the number of available characters for customer-specific information.

PIC32MZ Embedded Connectivity with Floating Point Unit (EF) Family

39.1 Package Marking Information (Continued)

100-Lead TQFP (12x12x1 mm)

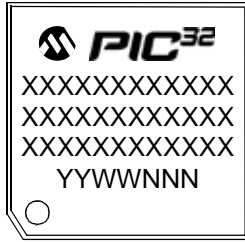

Example

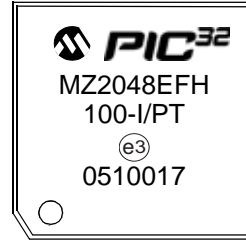

124-Lead VTLA (9x9x0.9 mm)

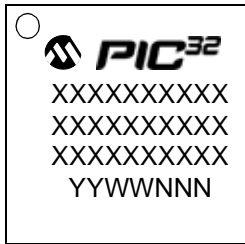

Example



144-Lead TQFP (16x16x1 mm)



Example



144-Lead LQFP (20x20x1.40 mm)



Example



| | | |
|----------------|---|--|
| Legend: | XX...X | Customer-specific information |
| | Y | Year code (last digit of calendar year) |
| | YY | Year code (last 2 digits of calendar year) |
| | WW | Week code (week of January 1 is week '01') |
| | NNN | Alphanumeric traceability code |
| | * | Pb-free JEDEC designator for Matte Tin (Sn) |
| | | This package is Pb-free. The Pb-free JEDEC designator (e3) can be found on the outer packaging for this package. |
| Note: | In the event the full Microchip part number cannot be marked on one line, it will be carried over to the next line, thus limiting the number of available characters for customer-specific information. | |

PIC32MZ Embedded Connectivity with Floating Point Unit (EF) Family

39.2 Package Details

64-Lead Plastic Quad Flat, No Lead Package (MR) – 9x9x0.9 mm Body with 5.40 x 5.40 Exposed Pad [QFN]

Note: For the most current package drawings, please see the Microchip Packaging Specification located at <http://www.microchip.com/packaging>

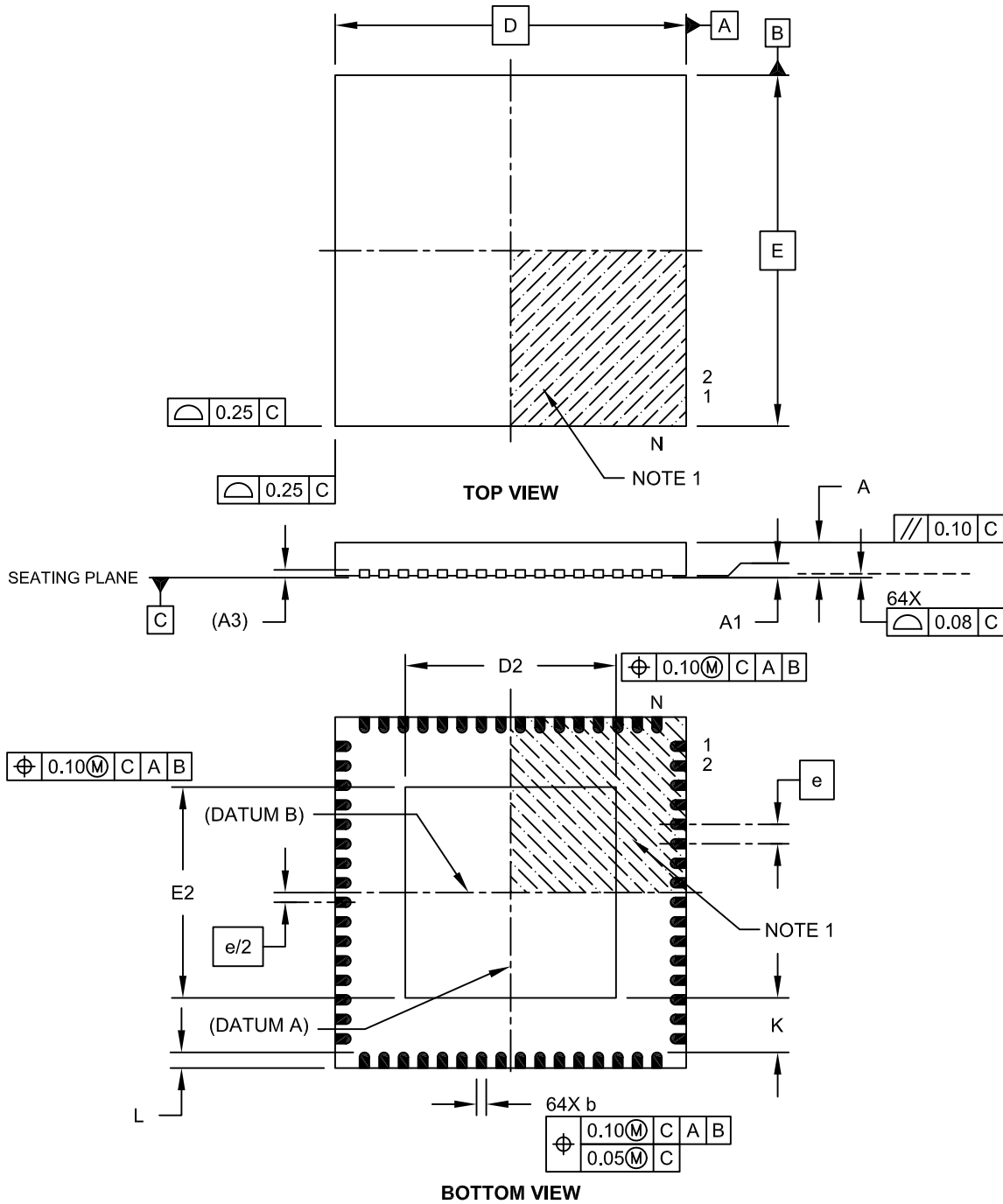

Microchip Technology Drawing C04-154A Sheet 1 of 2

PIC32MZ Embedded Connectivity with Floating Point Unit (EF) Family

64-Lead Plastic Quad Flat, No Lead Package (MR) – 9x9x0.9 mm Body with 5.40 x 5.40 Exposed Pad [QFN]

Note: For the most current package drawings, please see the Microchip Packaging Specification located at <http://www.microchip.com/packaging>

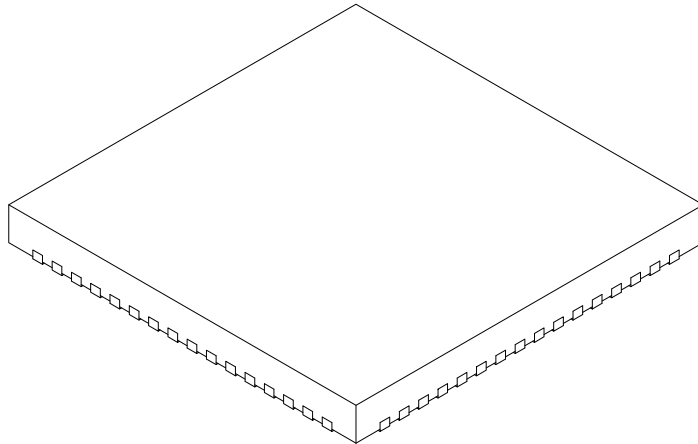

| Dimension Limits | Units | MILLIMETERS | | |
|------------------------|-------|-------------|------|------|
| | | MIN | NOM | MAX |
| Number of Pins | N | 64 | | |
| Pitch | e | 0.50 BSC | | |
| Overall Height | A | 0.80 | 0.90 | 1.00 |
| Standoff | A1 | 0.00 | 0.02 | 0.05 |
| Contact Thickness | A3 | 0.20 REF | | |
| Overall Width | E | 9.00 BSC | | |
| Exposed Pad Width | E2 | 5.30 | 5.40 | 5.50 |
| Overall Length | D | 9.00 BSC | | |
| Exposed Pad Length | D2 | 5.30 | 5.40 | 5.50 |
| Contact Width | b | 0.20 | 0.25 | 0.30 |
| Contact Length | L | 0.30 | 0.40 | 0.50 |
| Contact-to-Exposed Pad | K | 0.20 | - | - |

Notes:

1. Pin 1 visual index feature may vary, but must be located within the hatched area.
2. Package is saw singulated.
3. Dimensioning and tolerancing per ASME Y14.5M.

BSC: Basic Dimension. Theoretically exact value shown without tolerances.

REF: Reference Dimension, usually without tolerance, for information purposes only.

Microchip Technology Drawing C04-154A Sheet 2 of 2

PIC32MZ Embedded Connectivity with Floating Point Unit (EF) Family

64-Lead Plastic Quad Flat, No Lead Package (MR) – 9x9x0.9 mm Body [QFN]
With 0.40 mm Contact Length

Note: For the most current package drawings, please see the Microchip Packaging Specification located at <http://www.microchip.com/packaging>

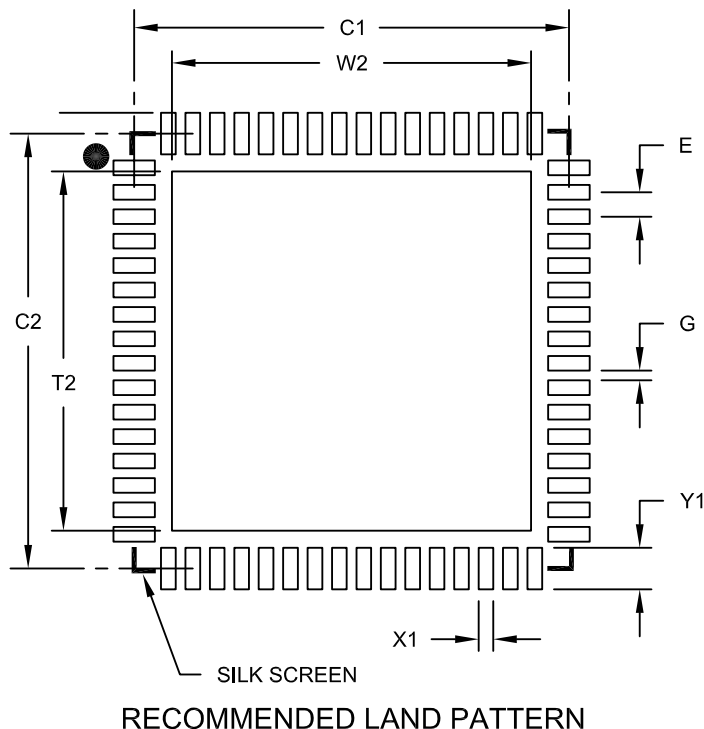

| Dimension Limits | Units | MILLIMETERS | | |
|----------------------------|-------|-------------|------|------|
| | | MIN | NOM | MAX |
| Contact Pitch | E | 0.50 BSC | | |
| Optional Center Pad Width | W2 | | | 7.35 |
| Optional Center Pad Length | T2 | | | 7.35 |
| Contact Pad Spacing | C1 | | 8.90 | |
| Contact Pad Spacing | C2 | | 8.90 | |
| Contact Pad Width (X64) | X1 | | | 0.30 |
| Contact Pad Length (X64) | Y1 | | | 0.85 |
| Distance Between Pads | G | 0.20 | | |

Notes:

1. Dimensioning and tolerancing per ASME Y14.5M

BSC: Basic Dimension. Theoretically exact value shown without tolerances.

Microchip Technology Drawing No. C04-2149A

PIC32MZ Embedded Connectivity with Floating Point Unit (EF) Family

64-Lead Plastic Thin Quad Flatpack (PT)-10x10x1 mm Body, 2.00 mm Footprint [TQFP]

Note: For the most current package drawings, please see the Microchip Packaging Specification located at <http://www.microchip.com/packaging>

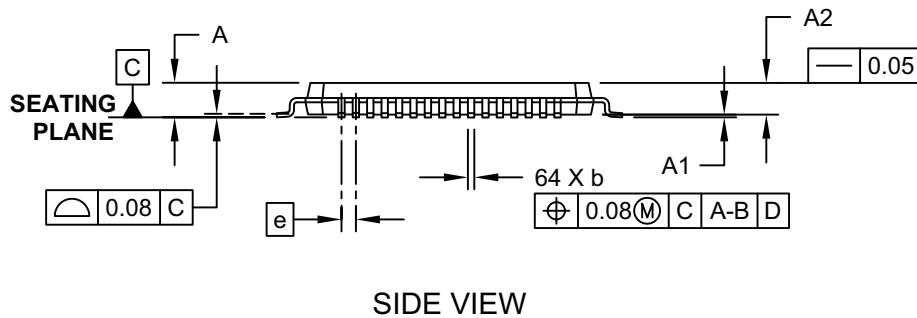
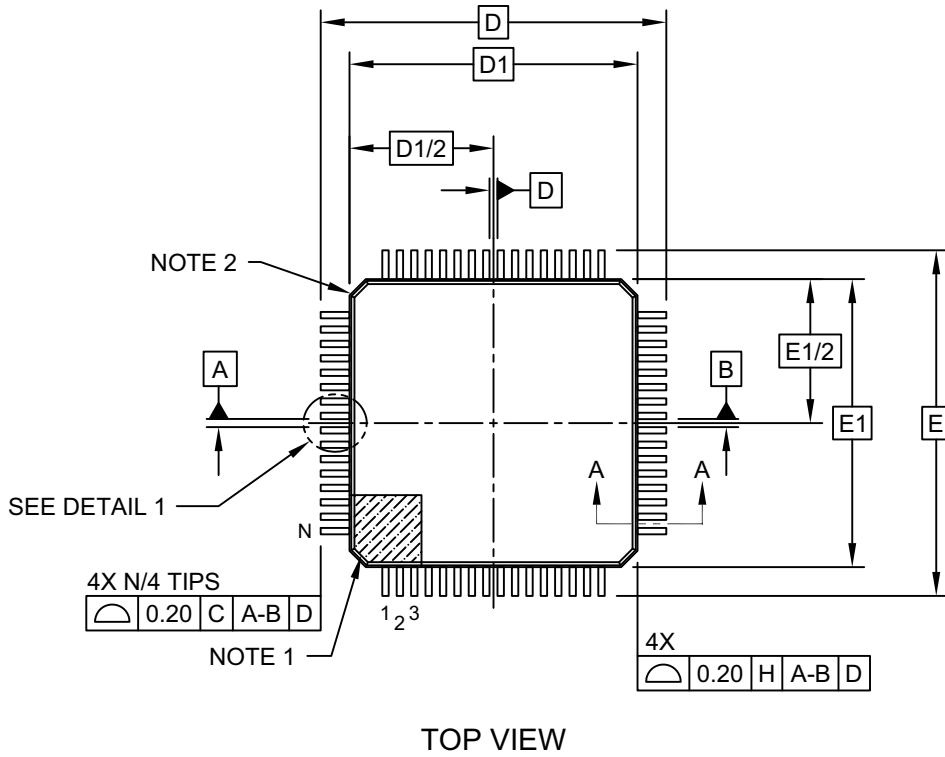

Microchip Technology Drawing C04-085C Sheet 1 of 2

PIC32MZ Embedded Connectivity with Floating Point Unit (EF) Family

64-Lead Plastic Thin Quad Flatpack (PT)-10x10x1 mm Body, 2.00 mm Footprint [TQFP]

Note: For the most current package drawings, please see the Microchip Packaging Specification located at <http://www.microchip.com/packaging>

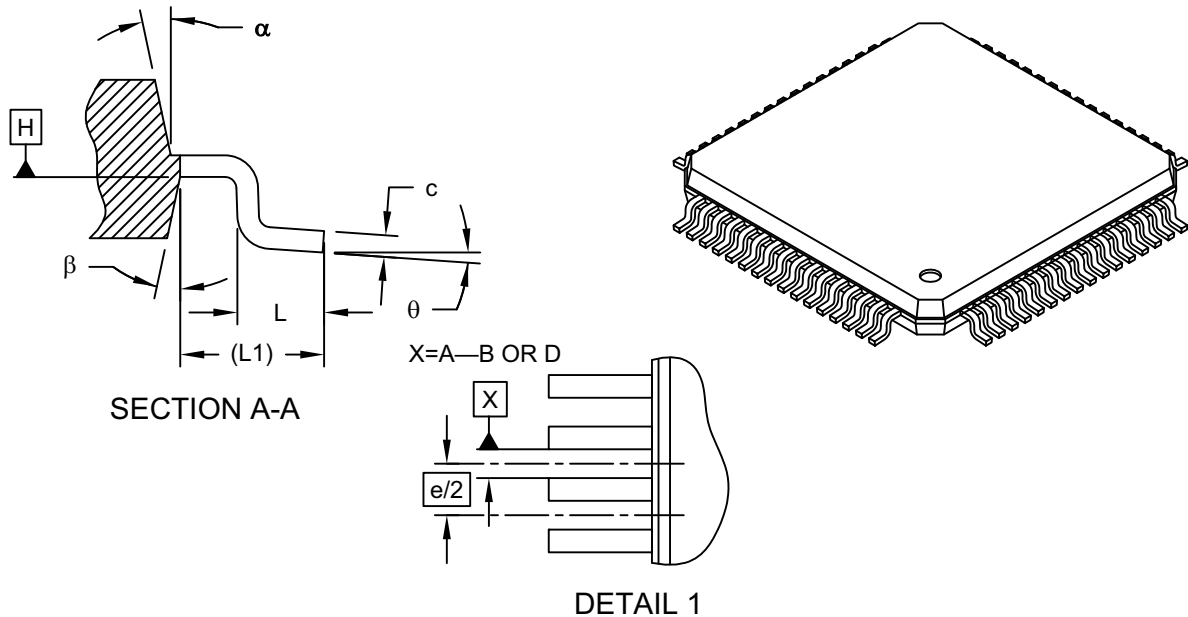

| Dimension Limits | Units | MILLIMETERS | | |
|--------------------------|----------|-------------|------|------|
| | | MIN | NOM | MAX |
| Number of Leads | N | 64 | | |
| Lead Pitch | e | 0.50 BSC | | |
| Overall Height | A | - | - | 1.20 |
| Molded Package Thickness | A2 | 0.95 | 1.00 | 1.05 |
| Standoff | A1 | 0.05 | - | 0.15 |
| Foot Length | L | 0.45 | 0.60 | 0.75 |
| Footprint | L1 | 1.00 REF | | |
| Foot Angle | ϕ | 0° | 3.5° | 7° |
| Overall Width | E | 12.00 BSC | | |
| Overall Length | D | 12.00 BSC | | |
| Molded Package Width | E1 | 10.00 BSC | | |
| Molded Package Length | D1 | 10.00 BSC | | |
| Lead Thickness | c | 0.09 | - | 0.20 |
| Lead Width | b | 0.17 | 0.22 | 0.27 |
| Mold Draft Angle Top | α | 11° | 12° | 13° |
| Mold Draft Angle Bottom | β | 11° | 12° | 13° |

Notes:

1. Pin 1 visual index feature may vary, but must be located within the hatched area.
2. Chamfers at corners are optional; size may vary.
3. Dimensions D1 and E1 do not include mold flash or protrusions. Mold flash or protrusions shall not exceed 0.25mm per side.
4. Dimensioning and tolerancing per ASME Y14.5M

BSC: Basic Dimension. Theoretically exact value shown without tolerances.

REF: Reference Dimension, usually without tolerance, for information purposes only.

Microchip Technology Drawing C04-085C Sheet 2 of 2

PIC32MZ Embedded Connectivity with Floating Point Unit (EF) Family

64-Lead Plastic Thin Quad Flatpack (PT)-10x10x1 mm Body, 2.00 mm Footprint [TQFP]

Note: For the most current package drawings, please see the Microchip Packaging Specification located at <http://www.microchip.com/packageing>

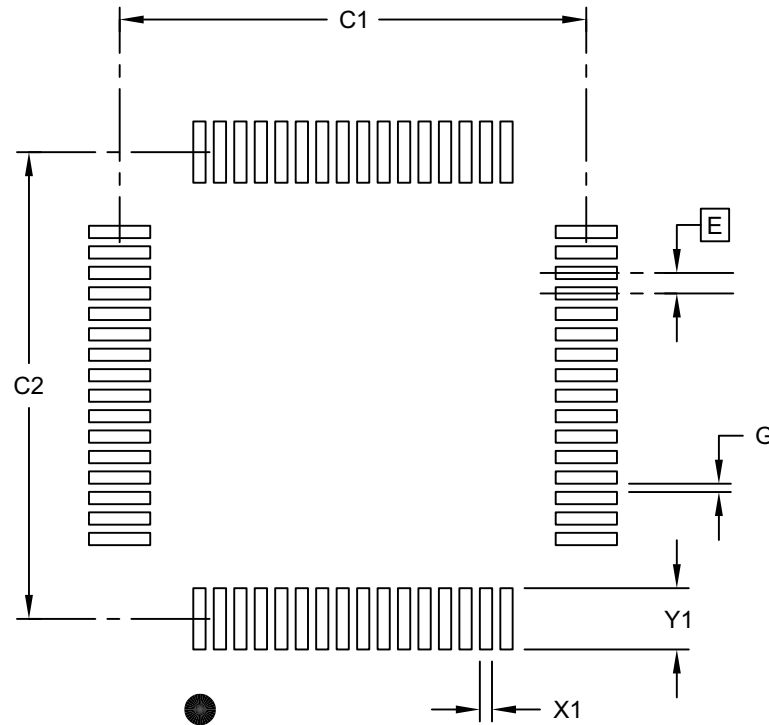

RECOMMENDED LAND PATTERN

| Dimension Limits | Units | MILLIMETERS | | |
|--------------------------|-------|-------------|-------|------|
| | | MIN | NOM | MAX |
| Contact Pitch | E | 0.50 BSC | | |
| Contact Pad Spacing | C1 | | 11.40 | |
| Contact Pad Spacing | C2 | | 11.40 | |
| Contact Pad Width (X28) | X1 | | | 0.30 |
| Contact Pad Length (X28) | Y1 | | | 1.50 |
| Distance Between Pads | G | 0.20 | | |

Notes:

1. Dimensioning and tolerancing per ASME Y14.5M

BSC: Basic Dimension. Theoretically exact value shown without tolerances.

Microchip Technology Drawing C04-2085B Sheet 1 of 1

PIC32MZ Embedded Connectivity with Floating Point Unit (EF) Family

100-Lead Plastic Thin Quad Flatpack (PF) – 14x14x1 mm Body, 2.00 mm [TQFP]

Note: For the most current package drawings, please see the Microchip Packaging Specification located at <http://www.microchip.com/packaging>

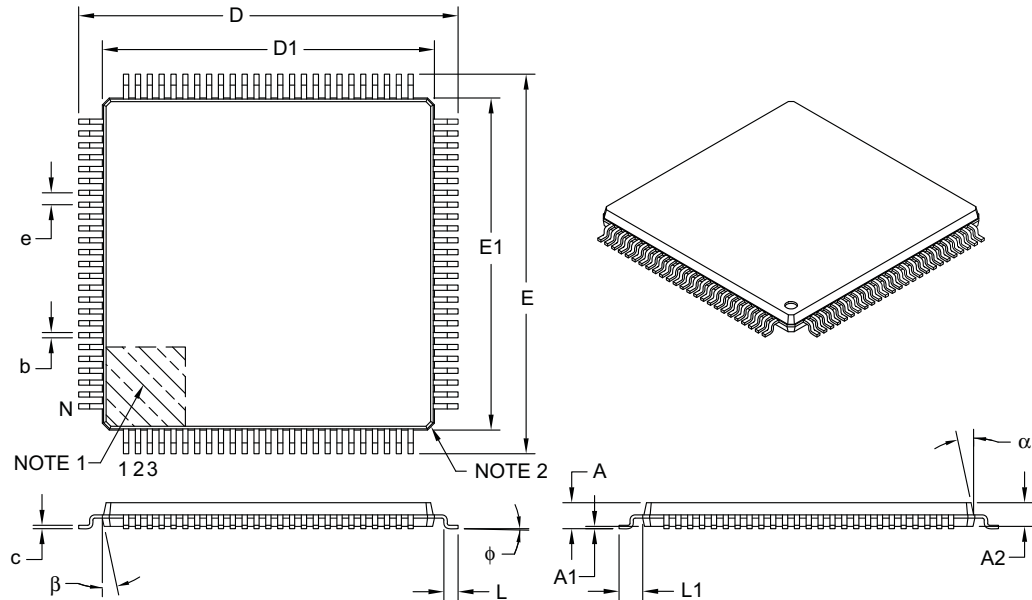

| | | Units | MILLIMETERS | | |
|--------------------------|----------|-------|-------------|------|------|
| Dimension Limits | | | MIN | NOM | MAX |
| Number of Leads | N | | 100 | | |
| Lead Pitch | e | | 0.50 BSC | | |
| Overall Height | A | – | – | – | 1.20 |
| Molded Package Thickness | A2 | | 0.95 | 1.00 | 1.05 |
| Standoff | A1 | | 0.05 | – | 0.15 |
| Foot Length | L | | 0.45 | 0.60 | 0.75 |
| Footprint | L1 | | 1.00 REF | | |
| Foot Angle | ϕ | | 0° | 3.5° | 7° |
| Overall Width | E | | 16.00 BSC | | |
| Overall Length | D | | 16.00 BSC | | |
| Molded Package Width | E1 | | 14.00 BSC | | |
| Molded Package Length | D1 | | 14.00 BSC | | |
| Lead Thickness | c | | 0.09 | – | 0.20 |
| Lead Width | b | | 0.17 | 0.22 | 0.27 |
| Mold Draft Angle Top | α | | 11° | 12° | 13° |
| Mold Draft Angle Bottom | β | | 11° | 12° | 13° |

Notes:

- Pin 1 visual index feature may vary, but must be located within the hatched area.
- Chamfers at corners are optional; size may vary.
- Dimensions D1 and E1 do not include mold flash or protrusions. Mold flash or protrusions shall not exceed 0.25 mm per side.
- Dimensioning and tolerancing per ASME Y14.5M.

BSC: Basic Dimension. Theoretically exact value shown without tolerances.

REF: Reference Dimension, usually without tolerance, for information purposes only.

Microchip Technology Drawing C04-110B

PIC32MZ Embedded Connectivity with Floating Point Unit (EF) Family

100-Lead Plastic Thin Quad Flatpack (PF) - 14x14x1 mm Body 2.00 mm Footprint [TQFP]

Note: For the most current package drawings, please see the Microchip Packaging Specification located at <http://www.microchip.com/packageing>

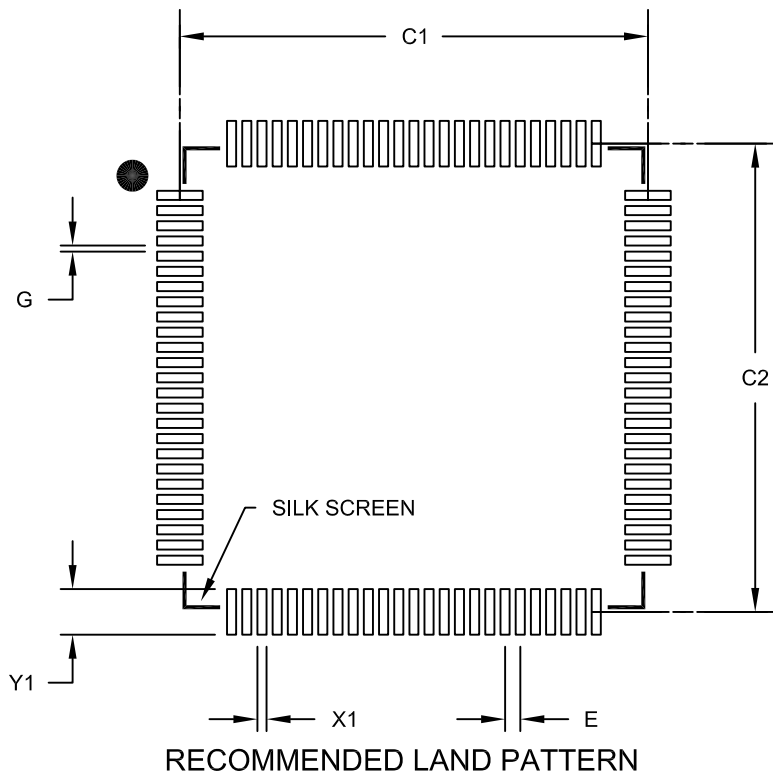

| Dimension Limits | Units | MILLIMETERS | | |
|---------------------------|-------|-------------|-------|------|
| | | MIN | NOM | MAX |
| Contact Pitch | E | 0.50 BSC | | |
| Contact Pad Spacing | C1 | | 15.40 | |
| Contact Pad Spacing | C2 | | 15.40 | |
| Contact Pad Width (X100) | X1 | | | 0.30 |
| Contact Pad Length (X100) | Y1 | | | 1.50 |
| Distance Between Pads | G | 0.20 | | |

Notes:

1. Dimensioning and tolerancing per ASME Y14.5M

BSC: Basic Dimension. Theoretically exact value shown without tolerances.

Microchip Technology Drawing No. C04-2110B

PIC32MZ Embedded Connectivity with Floating Point Unit (EF) Family

100-Lead Plastic Thin Quad Flatpack (PT) – 12x12x1 mm Body, 2.00 mm [TQFP]

Note: For the most current package drawings, please see the Microchip Packaging Specification located at <http://www.microchip.com/packaging>

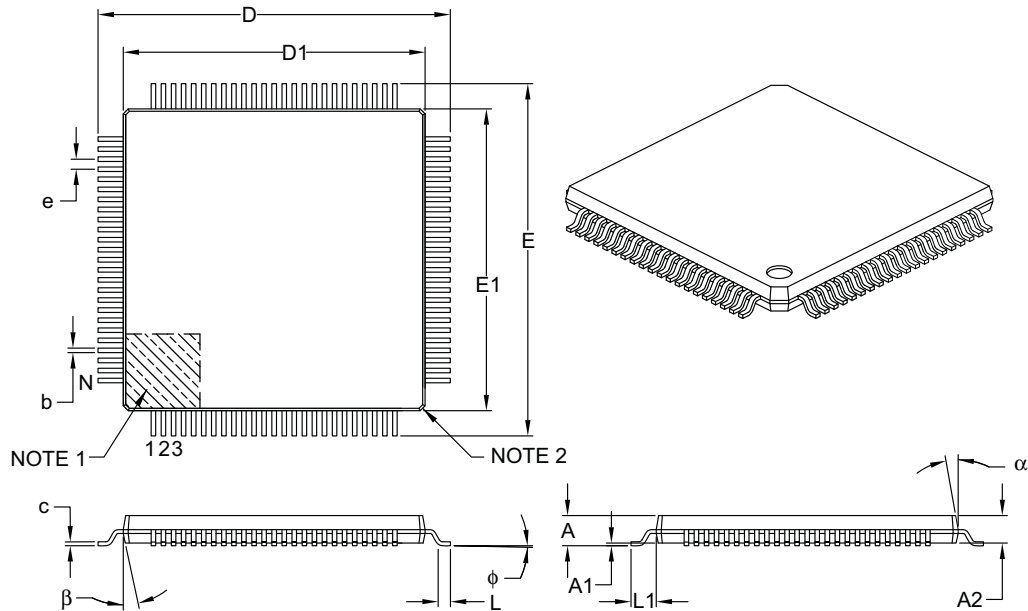

| Dimension Limits | Units | MILLIMETERS | | |
|--------------------------|-------|-------------|------|------|
| | | MIN | NOM | MAX |
| Number of Leads | N | 100 | | |
| Lead Pitch | e | 0.40 BSC | | |
| Overall Height | A | – | – | 1.20 |
| Molded Package Thickness | A2 | 0.95 | 1.00 | 1.05 |
| Standoff | A1 | 0.05 | – | 0.15 |
| Foot Length | L | 0.45 | 0.60 | 0.75 |
| Footprint | L1 | 1.00 REF | | |
| Foot Angle | φ | 0° | 3.5° | 7° |
| Overall Width | E | 14.00 BSC | | |
| Overall Length | D | 14.00 BSC | | |
| Molded Package Width | E1 | 12.00 BSC | | |
| Molded Package Length | D1 | 12.00 BSC | | |
| Lead Thickness | c | 0.09 | – | 0.20 |
| Lead Width | b | 0.13 | 0.18 | 0.23 |
| Mold Draft Angle Top | α | 11° | 12° | 13° |
| Mold Draft Angle Bottom | β | 11° | 12° | 13° |

Notes:

1. Pin 1 visual index feature may vary, but must be located within the hatched area.
2. Chamfers at corners are optional; size may vary.
3. Dimensions D1 and E1 do not include mold flash or protrusions. Mold flash or protrusions shall not exceed 0.25 mm per side.
4. Dimensioning and tolerancing per ASME Y14.5M.

BSC: Basic Dimension. Theoretically exact value shown without tolerances.

REF: Reference Dimension, usually without tolerance, for information purposes only.

Microchip Technology Drawing C04-100B

PIC32MZ Embedded Connectivity with Floating Point Unit (EF) Family

100-Lead Plastic Thin Quad Flatpack (PT)-12x12x1mm Body, 2.00 mm Footprint [TQFP]

Note: For the most current package drawings, please see the Microchip Packaging Specification located at <http://www.microchip.com/packaging>

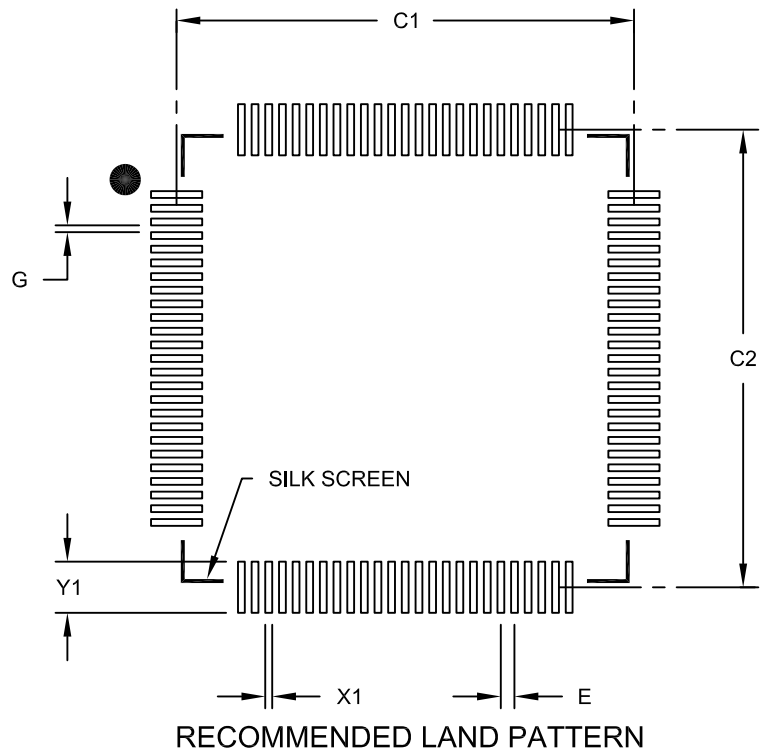

| Dimension Limits | Units | MILLIMETERS | | |
|---------------------------|-------|-------------|-------|------|
| | | MIN | NOM | MAX |
| Contact Pitch | E | 0.40 BSC | | |
| Contact Pad Spacing | C1 | | 13.40 | |
| Contact Pad Spacing | C2 | | 13.40 | |
| Contact Pad Width (X100) | X1 | | | 0.20 |
| Contact Pad Length (Y100) | Y1 | | | 1.50 |
| Distance Between Pads | G | 0.20 | | |

Notes:

1. Dimensioning and tolerancing per ASME Y14.5M

BSC: Basic Dimension. Theoretically exact value shown without tolerances.

Microchip Technology Drawing No. C04-2100B

PIC32MZ Embedded Connectivity with Floating Point Unit (EF) Family

124-Terminal Very Thin Leadless Array Package (TL) – 9x9x0.9 mm Body [VTLA]

Note: For the most current package drawings, please see the Microchip Packaging Specification located at <http://www.microchip.com/packaging>

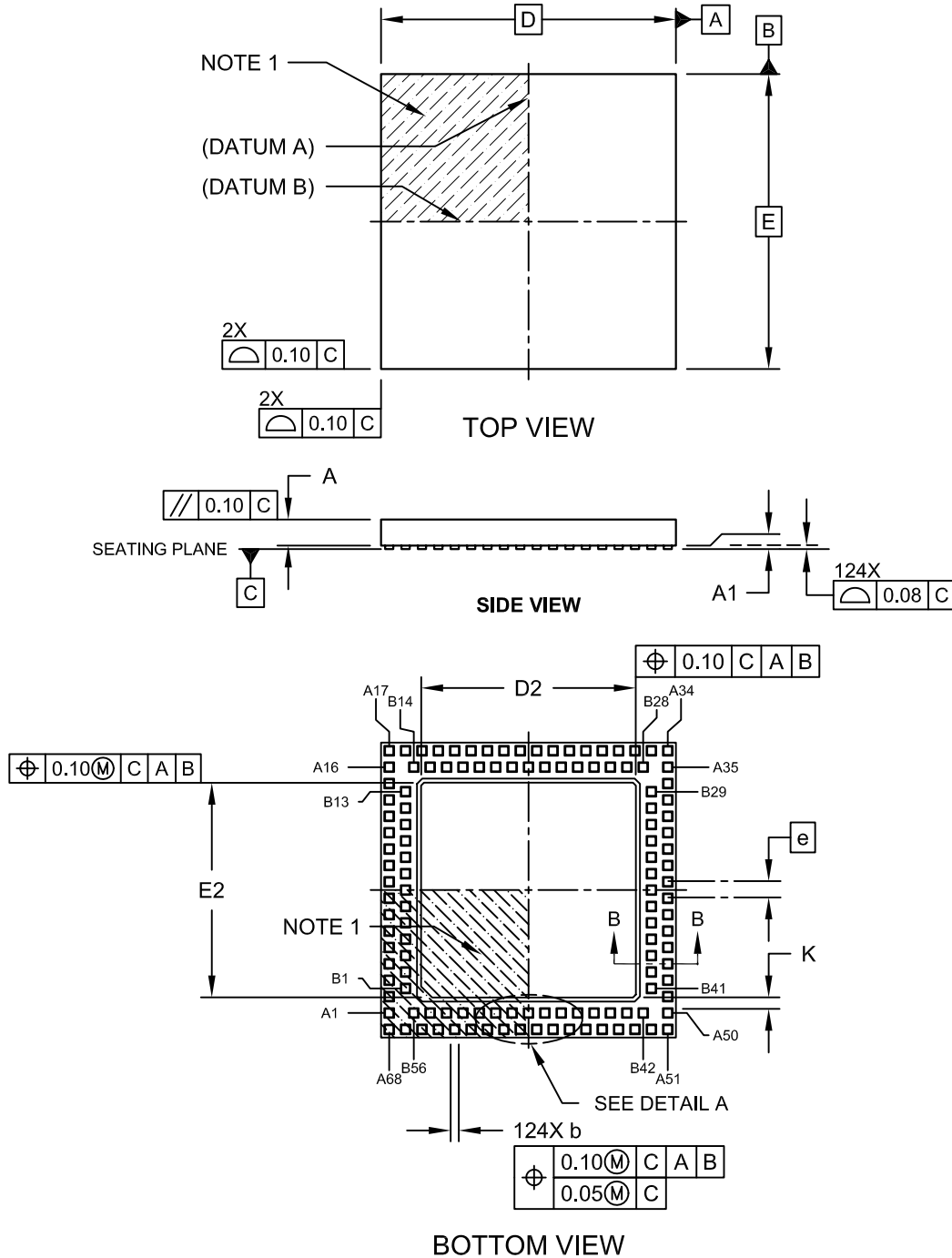

Microchip Technology Drawing C04-193A Sheet 1 of 2

PIC32MZ Embedded Connectivity with Floating Point Unit (EF) Family

124-Terminal Very Thin Leadless Array Package (TL) – 9x9x0.9 mm Body [VTLA]

Note: For the most current package drawings, please see the Microchip Packaging Specification located at <http://www.microchip.com/packaging>

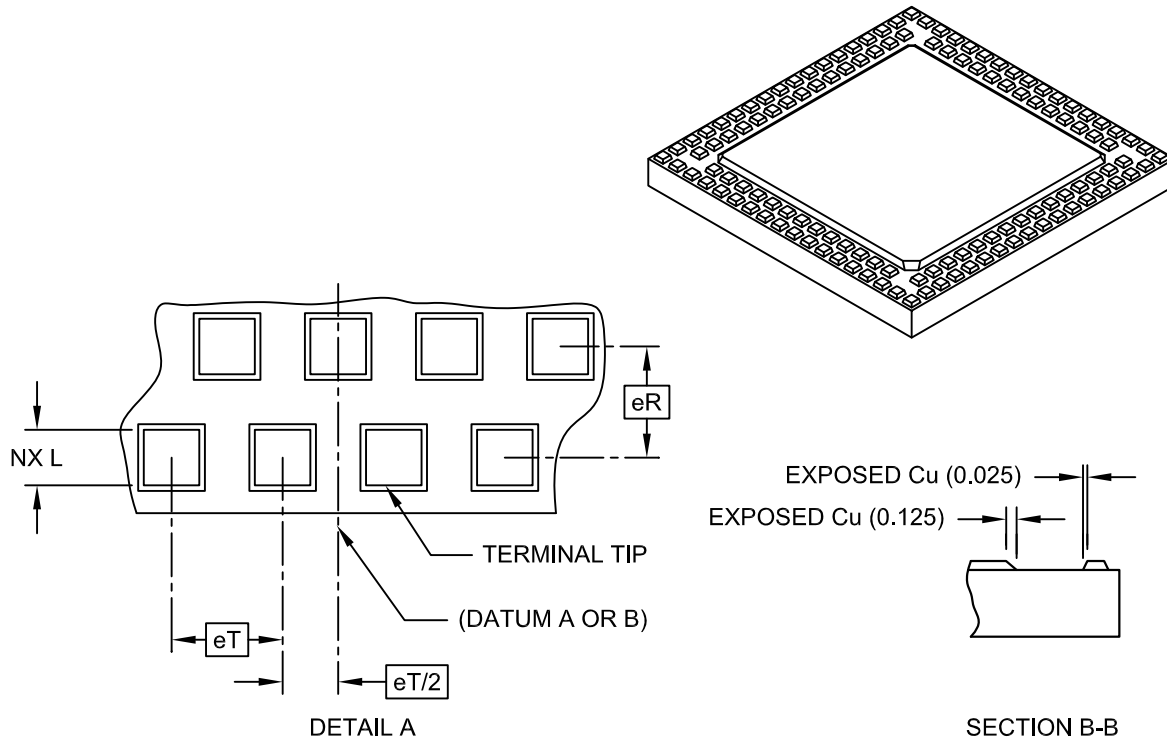

| Dimension Limits | Units | MILLIMETERS | | |
|--------------------------------------|-------|-------------|------|------|
| | | MIN | NOM | MAX |
| Number of Pins | N | 124 | | |
| Pitch | eT | 0.50 BSC | | |
| Pitch (Inner to outer terminal ring) | eR | 0.50 BSC | | |
| Overall Height | A | 0.80 | 0.85 | 0.90 |
| Standoff | A1 | 0.00 | - | 0.05 |
| Overall Width | E | 9.00 BSC | | |
| Exposed Pad Width | E2 | 6.40 | 6.55 | 6.70 |
| Overall Length | D | 9.00 BSC | | |
| Exposed Pad Length | D2 | 6.40 | 6.55 | 6.70 |
| Contact Width | b | 0.20 | 0.25 | 0.30 |
| Contact Length | L | 0.20 | 0.25 | 0.30 |
| Contact-to-Exposed Pad | K | 0.20 | - | - |

Notes:

- Pin 1 visual index feature may vary, but must be located within the hatched area.
- Package is saw singulated.
- Dimensioning and tolerancing per ASME Y14.5M.
 BSC: Basic Dimension. Theoretically exact value shown without tolerances.
 REF: Reference Dimension, usually without tolerance, for information purposes only.

Microchip Technology Drawing C04-193A Sheet 2 of 2

PIC32MZ Embedded Connectivity with Floating Point Unit (EF) Family

124-Very Thin Leadless Array Package (TL) – 9x9x0.9 mm Body [VTLA]

Note: For the most current package drawings, please see the Microchip Packaging Specification located at <http://www.microchip.com/packaging>

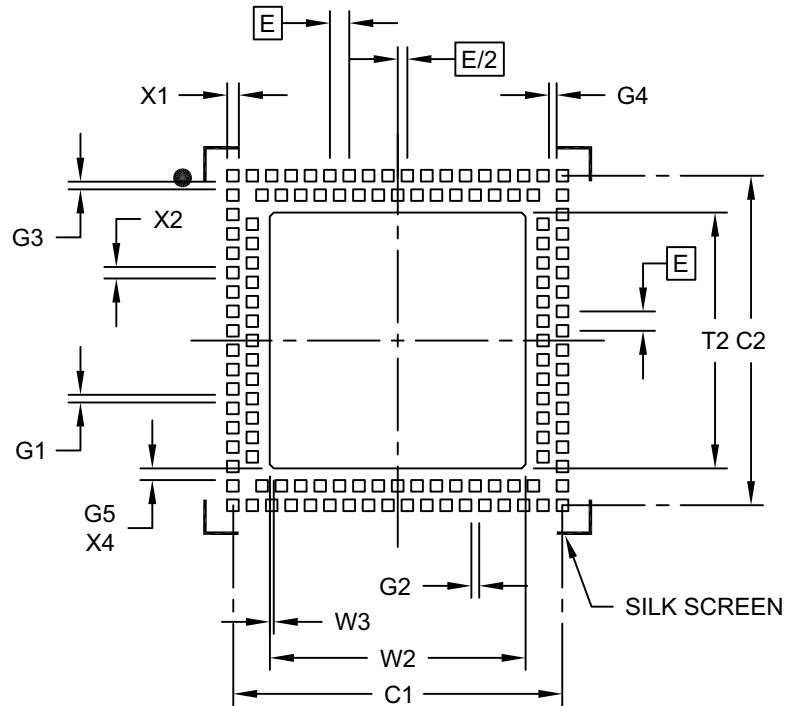

RECOMMENDED LAND PATTERN

| Dimension Limits | Units | MILLIMETERS | | |
|--------------------------------------|-------|-------------|------|------|
| | | MIN | NOM | MAX |
| Contact Pitch | E | 0.50 BSC | | |
| Pad Clearance | G1 | 0.20 | | |
| Pad Clearance | G2 | 0.20 | | |
| Pad Clearance | G3 | 0.20 | | |
| Pad Clearance | G4 | 0.20 | | |
| Contact to Center Pad Clearance (X4) | G5 | 0.30 | | |
| Optional Center Pad Width | T2 | | | 6.60 |
| Optional Center Pad Length | W2 | | | 6.60 |
| Optional Center Pad Chamfer (X4) | W3 | | 0.10 | |
| Contact Pad Spacing | C1 | | 8.50 | |
| Contact Pad Spacing | C2 | | 8.50 | |
| Contact Pad Width (X124) | X1 | | | 0.30 |
| Contact Pad Length (X124) | X2 | | | 0.30 |

Notes:

1. Dimensioning and tolerancing per ASME Y14.5M

BSC: Basic Dimension. Theoretically exact value shown without tolerances.

Microchip Technology Drawing No. C04-2193A

PIC32MZ Embedded Connectivity with Floating Point Unit (EF) Family

144-Lead Plastic Thin Quad Flatpack (PH)-16x16x1mm Body, 2.00 mm Footprint [TQFP]

Note: For the most current package drawings, please see the Microchip Packaging Specification located at <http://www.microchip.com/packaging>

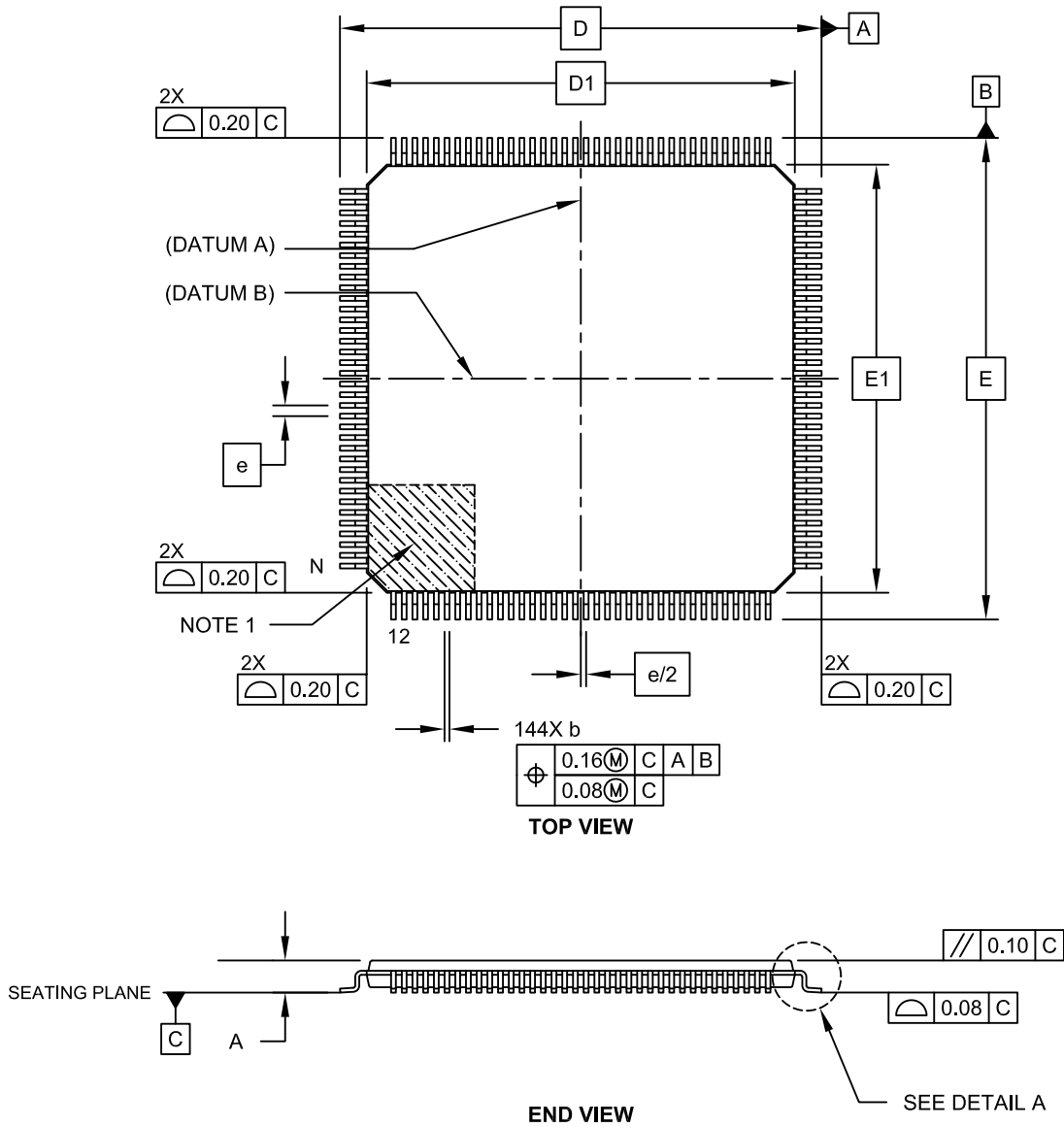

Microchip Technology Drawing C04-155B Sheet 1 of 2

PIC32MZ Embedded Connectivity with Floating Point Unit (EF) Family

144-Lead Plastic Thin Quad Flatpack (PH)-16x16x1mm Body, 2.00 mm Footprint [TQFP]

Note: For the most current package drawings, please see the Microchip Packaging Specification located at <http://www.microchip.com/packaging>

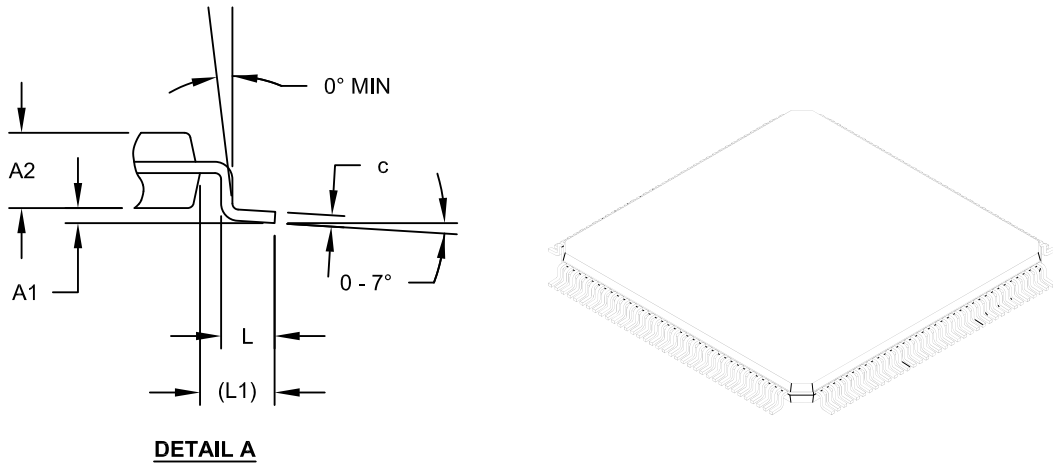

| Dimension | Units | MILLIMETERS | | |
|--------------------------|-------|-------------|------|------|
| | | MIN | NOM | MAX |
| Number of Pins | N | 144 | | |
| Lead Pitch | e | 0.40 BSC | | |
| Overall Height | A | - | - | 1.20 |
| Molded Package Thickness | A2 | 0.95 | 1.00 | 1.05 |
| Standoff | A1 | 0.05 | - | 0.15 |
| Foot Length | L | 0.45 | 0.60 | 0.75 |
| Footprint | L1 | 1.00 REF | | |
| Overall Width | D | 18.00 BSC | | |
| Overall Length | E | 18.00 BSC | | |
| Molded Body Width | D1 | 16.00 BSC | | |
| Molded Body Length | E1 | 16.00 BSC | | |
| Lead Thickness | c | 0.09 | - | 0.20 |
| Lead Width | b | 0.13 | - | 0.23 |

Notes:

1. Pin 1 visual index feature may vary, but must be located within the hatched area.
2. Package is saw singulated.
3. Dimensioning and tolerancing per ASME Y14.5M.
BSC: Basic Dimension. Theoretically exact value shown without tolerances.
REF: Reference Dimension, usually without tolerance, for information purposes only.

Microchip Technology Drawing C04-155B Sheet 2 of 2

PIC32MZ Embedded Connectivity with Floating Point Unit (EF) Family

144-Lead Plastic Thin Quad Flat Pack (PH) - 16x16 mm Body, 2.00 mm Footprint [TQFP]

Note: For the most current package drawings, please see the Microchip Packaging Specification located at <http://www.microchip.com/packaging>

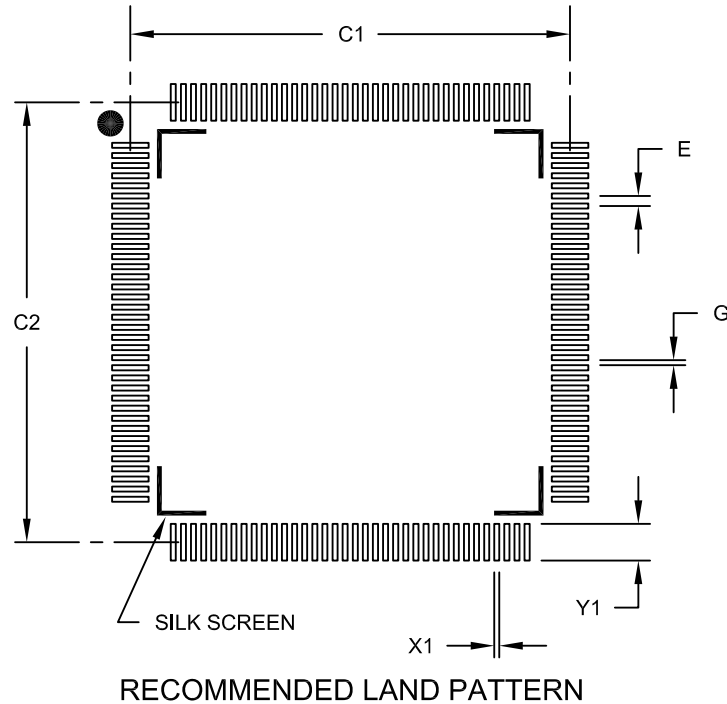

| Units | | MILLIMETERS | | |
|---------------------------|----|-------------|-------|------|
| Dimension Limits | | MIN | NOM | MAX |
| Contact Pitch | E | 0.40 BSC | | |
| Contact Pad Spacing | C1 | | 17.40 | |
| Contact Pad Spacing | C2 | | 17.40 | |
| Contact Pad Width (X144) | X1 | | | 0.20 |
| Contact Pad Length (X144) | Y1 | | | 1.45 |
| Distance Between Pads | G | 0.20 | | |

Notes:

1. Dimensioning and tolerancing per ASME Y14.5M

BSC: Basic Dimension. Theoretically exact value shown without tolerances.

Microchip Technology Drawing No. C04-2155B

PIC32MZ Embedded Connectivity with Floating Point Unit (EF) Family

144-Lead Plastic Low Profile Quad Flatpack (PL) – 20x20x1.40 mm Body, with 2.00 mm Footprint [LQFP]

Note: For the most current package drawings, please see the Microchip Packaging Specification located at <http://www.microchip.com/packaging>

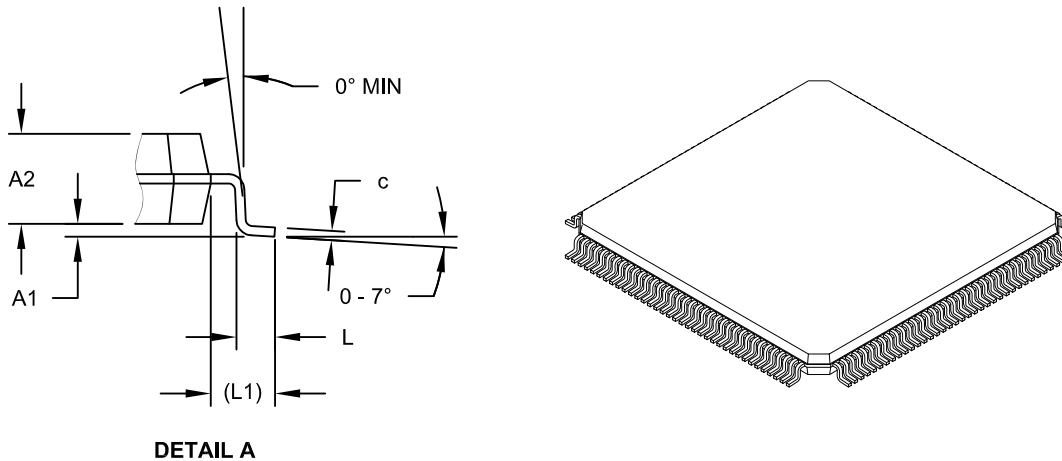

| Dimension Limits | Units | MILLIMETERS | | |
|-----------------------|-------|-------------|----------|------|
| | | MIN | NOM | MAX |
| Number of Leads | N | | 144 | |
| Lead Pitch | e | | 0.50 BSC | |
| Overall Height | A | - | - | 1.60 |
| Molded Package Height | A2 | 1.35 | 1.40 | 1.45 |
| Standoff | A1 | 0.05 | - | 0.15 |
| Foot Length | L | 0.45 | 0.60 | 0.75 |
| Footprint | L1 | 1.00 (REF) | | |
| Overall Width | E | 22.00 BSC | | |
| Overall Length | D | 22.00 BSC | | |
| Molded Body Width | E1 | 20.00 BSC | | |
| Molded Body Length | D1 | 20.00 BSC | | |
| Lead Thickness | c | 0.09 | - | 0.20 |
| Lead Width | b | 0.17 | 0.22 | 0.27 |

Notes:

- Pin 1 visual index feature may vary, but must be located within the hatched area.
- Package is saw singulated.
- Dimensioning and tolerancing per ASME Y14.5M.
 BSC: Basic Dimension. Theoretically exact value shown without tolerances.
 REF: Reference Dimension, usually without tolerance, for information purposes only.

Microchip Technology Drawing C04-044B Sheet 2 of 2

PIC32MZ Embedded Connectivity with Floating Point Unit (EF) Family

144-Lead Plastic Low Profile Quad Flatpack (PL) - 20x20x1.40 mm Body [LQFP]
2.00 mm Footprint

Note: For the most current package drawings, please see the Microchip Packaging Specification located at <http://www.microchip.com/packaging>

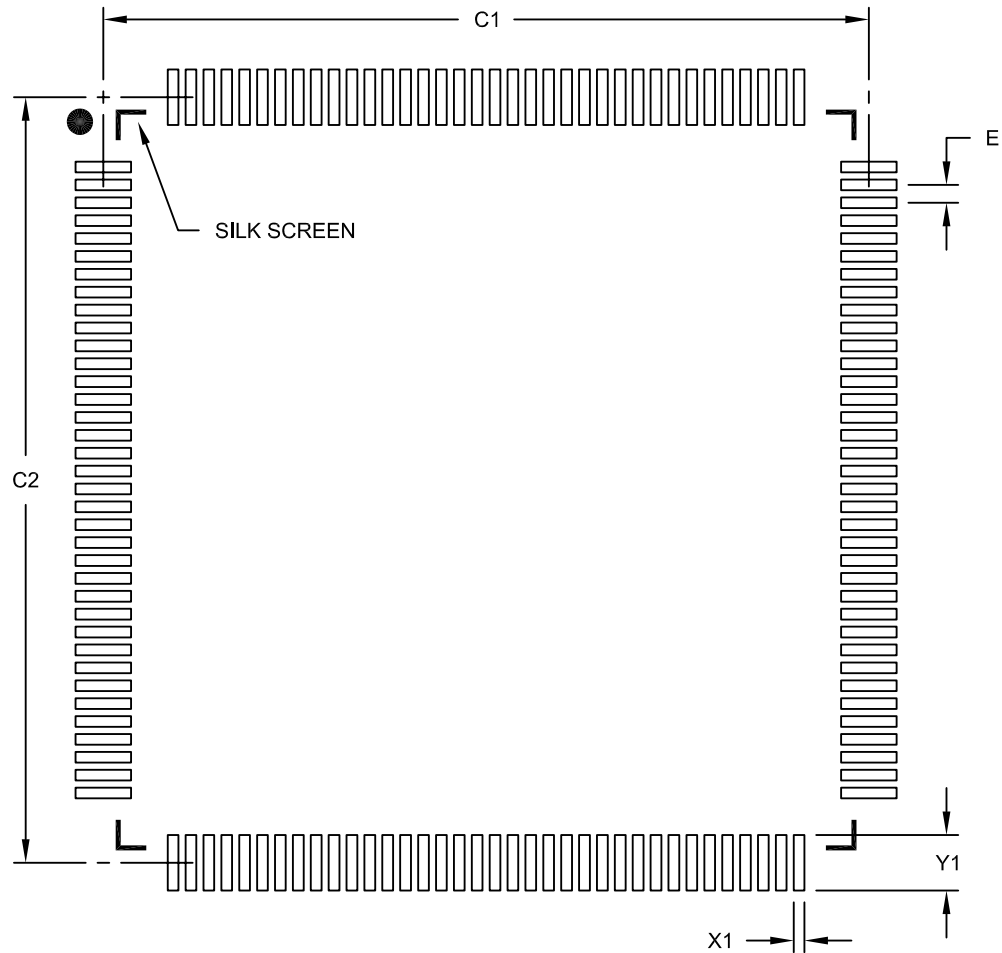

RECOMMENDED LAND PATTERN

| Dimension Limits | Units | MILLIMETERS | | |
|---------------------------|-------|-------------|----------|------|
| | | MIN | NOM | MAX |
| Contact Pitch | E | | 0.50 BSC | |
| Contact Pad Spacing | C1 | | 21.40 | |
| Contact Pad Spacing | C2 | | 21.40 | |
| Contact Pad Width (X144) | X1 | | | 0.30 |
| Contact Pad Length (X144) | Y1 | | | 1.55 |

Notes:

1. Dimensioning and tolerancing per ASME Y14.5M

BSC: Basic Dimension. Theoretically exact value shown without tolerances.

Microchip Technology Drawing No. C04-2044B

PIC32MZ Embedded Connectivity with Floating Point Unit (EF) Family

NOTES:

PIC32MZ Embedded Connectivity with Floating Point Unit (EF) Family

APPENDIX A: MIGRATING FROM PIC32MX5XX/6XX/7XX TO PIC32MZ EF

This appendix provides an overview of considerations for migrating from PIC32MX5XX/6XX/7XX devices to the PIC32MZ EF family of devices. The code developed for PIC32MX5XX/6XX/7XX devices can be ported to PIC32MZ EF devices after making the appropriate changes outlined in the following sections.

The PIC32MZ EF devices are based on a new architecture, and feature many improvements and new capabilities over PIC32MX5XX/6XX/7XX devices.

A.1 Oscillator and PLL Configuration

Because the maximum speed of the PIC32MZ EF family is 200 MHz, the configuration of the oscillator is different from prior PIC32MX5XX/6XX/7XX devices.

[Table A-1](#) summarizes the differences (indicated by **Bold type**) between the family devices for the oscillator.

TABLE A-1: OSCILLATOR CONFIGURATION DIFFERENCES

| PIC32MX5XX/6XX/7XX Feature | PIC32MZ EF Feature |
|--|---|
| Primary Oscillator Configuration | |
| <p>On PIC32MX devices, XT mode had to be selected if the input frequency was in the 3 MHz to 10 MHz range (4-10 for PLL), and HS mode had to be selected if the input frequency was in the 10 MHz to 20 MHz range.</p> <p>POSCMOD<1:0> (DEVCFG1<9:8>) 11 = Primary Oscillator disabled 10 = HS Oscillator mode selected 01 = XT Oscillator mode selected 00 = External Clock mode selected</p> | <p>On PIC32MZ EF devices, HS mode has a wider input frequency range (4 MHz to 12 MHz). The bit setting of '01' is Reserved.</p> <p>POSCMOD<1:0> (DEVCFG1<9:8>) 11 = Primary Oscillator disabled 10 = HS Oscillator mode selected 01 = Reserved 00 = External Clock mode selected</p> |
| Oscillator Selection | |
| <p>On PIC32MX devices, clock selection choices are as follows:</p> <p>FNOSC<2:0> (DEVCFG1<2:0>) NOSC<2:0> (OSCCON<10:8>) 111 = FRCDIV 110 = FRCDIV16 101 = LPRC 100 = SOSC 011 = POSC with PLL module 010 = POSC (XT, HS, EC) 001 = FRCDIV+PLL 000 = FRC</p> <p>COSC<2:0> (OSCCON<14:12>) 111 = FRC divided by FRCDIV 110 = FRC divided by 16 101 = LPRC 100 = SOSC 011 = POSC + PLL module 010 = POSC 001 = FRCPLL 000 = FRC</p> | <p>On PIC32MZ EF devices, clock selection choices are as follows:</p> <p>FNOSC<2:0> (DEVCFG1<2:0>) NOSC<2:0> (OSCCON<10:8>) 111 = FRCDIV 110 = Reserved 101 = LPRC 100 = SOSC 011 = Reserved 010 = POSC (HS or EC) 001 = System PLL (SPLL) 000 = FRCDIV</p> <p>COSC<2:0> (OSCCON<14:12>) 111 = FRC divided by FRCDIV 110 = BFRC 101 = LPRC 100 = SOSC 011 = Reserved 010 = POSC 001 = System PLL 000 = FRC divided by FRCDIV</p> |
| Secondary Oscillator Enable | |
| <p>FSOSCEN (DEVCFG1<5>)</p> | <p>The location of the SOSCCEN bit in the Flash Configuration Words has moved.</p> <p>FSOSCEN (DEVCFG1<6>)</p> |

PIC32MZ Embedded Connectivity with Floating Point Unit (EF) Family

TABLE A-1: OSCILLATOR CONFIGURATION DIFFERENCES (CONTINUED)

| PIC32MX5XX/6XX/7XX Feature | PIC32MZ EF Feature |
|---|---|
| PLL Configuration | |
| <p>The FNOSC<2:0> and NOSC<2:0> bits select between POSC and FRC.</p> <p>FNOSC<2:0> (DEVCFG1<2:0>) NOSC<2:0> (OSCCON<10:8>)</p> | <p>Selection of which input clock (POSC or FRC) is now done through the FPLLICK/PLLICK bits.</p> <p>FPLLICK (DEVCFG2<7>) PLLICK (SPLLCON<7>)</p> |
| <p>On PIC32MX devices, the input frequency to the PLL had to be between 4 MHz and 5 MHz. FPLLIDIV selected how to divide the input frequency to give it the appropriate range.</p> <p>FPLLIDIV<2:0> (DEVCFG2<2:0>) 111 = 12x divider 110 = 10x divider 101 = 6x divider 100 = 5x divider 011 = 4x divider 010 = 3x divider 001 = 2x divider 000 = 1x divider</p> | <p>On PIC32MZ EF devices, the input range for the PLL is wider (5 MHz to 64 MHz). The input divider values have changed, and new FPLLNRNG/PLLNRNG bits have been added to indicate under what range the input frequency falls.</p> <p>FPLLIDIV<2:0> (DEVCFG2<2:0>) PLLIDIV<2:0> (SPLLCON<2:0>) 111 = Divide by 8 110 = Divide by 7 101 = Divide by 6 100 = Divide by 5 011 = Divide by 4 010 = Divide by 3 001 = Divide by 2 000 = Divide by 1</p> <p>FPLLNRNG<2:0> (DEVCFG2<6:4>) PLLNRNG<2:0> (SPLLCON<2:0>) 111 = Reserved 110 = Reserved 101 = 34-64 MHz 100 = 21-42 MHz 011 = 13-26 MHz 010 = 8-16 MHz 001 = 5-10 MHz 000 = Bypass</p> |
| <p>On PIC32MX devices, the output frequency of PLL is between 60 MHz and 120 MHz. The PLL multiplier and divider bits configure the PLL for this range.</p> <p>FPLLMULT<2:0> (DEVCFG2<6:4>) PLLMULT<2:0> (OSCCON<18:16>) 111 = 24x multiplier 110 = 21x multiplier 101 = 20x multiplier 100 = 19x multiplier 011 = 18x multiplier 010 = 17x multiplier 001 = 16x multiplier 000 = 15x multiplier</p> <p>FPLLODIV<2:0> (DEVCFG2<18:16>) PLLODIV<2:0> (OSCCON<29:27>) 111 = 24x multiplier 110 = 21x multiplier 101 = 20x multiplier 100 = 19x multiplier 011 = 18x multiplier 010 = 17x multiplier 001 = 16x multiplier 000 = 15x multiplier</p> | <p>The PLL multiplier and divider on PIC32MZ EF devices have a wider range to accommodate the wider PLL specification range of 10 MHz to 200 MHz.</p> <p>FPLLMULT<6:0> (DEVCFG2<14:8>) PLLMULT<6:0> (SPLLCON<22:16>) 1111111 = Multiply by 128 1111110 = Multiply by 127 1111101 = Multiply by 126 1111100 = Multiply by 125 • • • 0000000 = Multiply by 1</p> <p>FPLLODIV<2:0> (DEVCFG2<18:16>) PLLODIV<2:0> (SPLLCON<26:24>) 111 = PLL Divide by 32 110 = PLL Divide by 32 101 = PLL Divide by 32 100 = PLL Divide by 16 011 = PLL Divide by 8 010 = PLL Divide by 4 001 = PLL Divide by 2 000 = PLL Divide by 2</p> |

PIC32MZ Embedded Connectivity with Floating Point Unit (EF) Family

TABLE A-1: OSCILLATOR CONFIGURATION DIFFERENCES (CONTINUED)

| PIC32MX5XX/6XX/7XX Feature | PIC32MZ EF Feature |
|--|---|
| Crystal/Oscillator Selection for USB | |
| Any frequency that can be divided down to 4 MHz using UPLLIDIV, including 4, 8, 12, 16, 20, 40, and 48 MHz. | If the USB module is used, the Primary Oscillator is limited to either 12 MHz or 24 MHz. Which frequency is used is selected using the UPLLFSEL (DEVCFG2<30>) bit. |
| USB PLL Configuration | |
| On PIC32MX devices, the PLL for the USB requires an input frequency of 4 MHz. UPLLIDIV<2:0> (DEVCFG2<10:8>) 111 = 12x divider 110 = 10x divider 101 = 6x divider 100 = 5x divider 011 = 4x divider 010 = 3x divider 010 = 3x divider 001 = 2x divider 000 = 1x divider | On PIC32MZ EF devices, the HS USB PHY requires an input frequency of 12 MHz or 24 MHz. UPLLIDIV has been replaced with UPLLFSEL. UPLLFSEL (DEVCFG2<30>) 1 = UPLL input clock is 24 MHz 0 = UPLL input clock is 12 MHz |
| Peripheral Bus Clock Configuration | |
| On PIC32MX devices, there is one peripheral bus, and the clock for that bus is divided from the SYSCLK using FPBDIV/PBDIV. In addition, the maximum PBCLK frequency is the same as SYSCLK. FPBDIV<1:0> (DEVCFG1<5:4>) PBDIV<1:0> (OSCCON<20:19>) 11 = PBCLK is SYSCLK divided by 8 10 = PBCLK is SYSCLK divided by 4 01 = PBCLK is SYSCLK divided by 2 00 = PBCLK is SYSCLK divided by 1 | On PIC32MZ EF devices, there are eight peripheral buses with their own clocks. FPBDIV is removed, and each PBDIV is in its own register for each PBCLK. The initial PBCLK speed is fixed at reset, and the maximum PBCLK speed is limited to 100 MHz for all buses, with the exception of PBCLK7, which is 200 MHz. PBDIV<6:0> (PBxDIV<6:0>) 1111111 = PBCLKx is SYSCLK divided by 128 1111110 = PBCLKx is SYSCLK divided by 127 • • • 0000011 = PBCLKx is SYSCLK divided by 4 0000010 = PBCLKx is SYSCLK divided by 3 0000001 = PBCLKx is SYSCLK divided by 2 (default value for x < 7) 0000000 = PBCLKx is SYSCLK divided by 1 (default value for x ≥ 7) |
| CPU Clock Configuration | |
| On PIC32MX devices, the CPU clock is derived from SYSCLK. | On PIC32MZ EF devices, the CPU clock is derived from PBCLK7. |
| FRCDIV Default | |
| On PIC32MX devices, the default value for FRCDIV was to divide the FRC clock by two. FRCDIV<2:0> (OSCCON<26:24>) 111 = FRC divided by 256 110 = FRC divided by 64 101 = FRC divided by 32 100 = FRC divided by 16 011 = FRC divided by 8 010 = FRC divided by 4 001 = FRC divided by 2 (default) 000 = FRC divided by 1 | On PIC32MZ EF devices, the default has been changed to divide by one. FRCDIV<2:0> (OSCCON<26:24>) 111 = FRC divided by 256 110 = FRC divided by 64 101 = FRC divided by 32 100 = FRC divided by 16 011 = FRC divided by 8 010 = FRC divided by 4 001 = FRC divided by 2 000 = FRC divided by 1 (default) |

PIC32MZ Embedded Connectivity with Floating Point Unit (EF) Family

TABLE A-1: OSCILLATOR CONFIGURATION DIFFERENCES (CONTINUED)

| PIC32MX5XX/6XX/7XX Feature | PIC32MZ EF Feature |
|---|---|
| Fail-Safe Clock Monitor (FSCM) | |
| On PIC32MX devices, the internal FRC became the clock source on a failure of the clock source. | On PIC32MZ EF devices, a separate internal Backup FRC (BFRC) becomes the clock source upon a failure at the clock source. |
| On PIC32MX devices, a clock failure resulted in the triggering of a specific interrupt when the switchover was complete. FSCM generates an interrupt. | On PIC32MZ EF devices, a NMI is triggered instead, and must be handled by the NMI routine. FSCM generates a NMI. |
| FCKSM<1:0> (DEVCFG1<15:14>) 1x = Clock switching is disabled, FSCM is disabled 01 = Clock switching is enabled, FSCM is disabled 00 = Clock switching is enabled, FSCM is enabled | The definitions of the FCKSM<1:0> bits has changed on PIC32MZ EF devices. FCKSM<1:0> (DEVCFG1<15:14>) 11 = Clock switching is enabled and clock monitoring is enabled 10 = Clock switching is disabled and clock monitoring is enabled 01 = Clock switching is enabled and clock monitoring is disabled 00 = Clock switching is disabled and clock monitoring is disabled |
| On PIC32MX devices, the CF (OSCCON<3>) bit indicates a clock failure. Writing to this bit initiates a FSCM event. | On PIC32MZ EF devices, the CF (OSCCON<3>) bit has the same functionality as that of PIC32MX device; however, an additional CF(RNMICON<1>) bit is available to indicate a NMI event. Writing to this bit causes a NMI event, but not a FSCM event. |
| On PIC32MX devices, the CLKLOCK (OSCCON<7>) bit is controlled by the FSCM. CLKLOCK (OSCCON<7>) If clock switching and monitoring is disabled (FCKSM<1:0> = 1x): 1 = Clock and PLL selections are locked 0 = Clock and PLL selections are not locked and may be modified If clock switching and monitoring is enabled (FCKSM<1:0> = 0x): Clock and PLL selections are never locked and may be modified. | On PIC32MZ EF devices, the CLKLOCK (OSCCON<7>) bit is not impacted by the FSCM. CLKLOCK (OSCCON<7>) 1 = Clock and PLL selections are locked 0 = Clock and PLL selections are not locked and may be modified |

Table A-2 illustrates the difference in code setup of the respective parts for maximum speed using an external 24 MHz crystal.

TABLE A-2: CODE DIFFERENCES FOR MAXIMUM SPEED USING AN EXTERNAL 24 MHz CRYSTAL

| PIC32MX5XX/6XX/7XX @ 80 Hz | PIC32MZ EF @ 200 MHz |
|--|--|
| <pre>#include <xc.h> #pragma config POSCMOD = HS #pragma config FNOSC = PRIPLL #pragma config FPLLIDIV = DIV_6 #pragma config FPLLMUL = MUL_20 #pragma config FPLLODIV = DIV_1 #define SYSFREQ (80000000L)</pre> | <pre>#include <xc.h> #pragma config POSCMOD = HS #pragma config FNOSC = SPLL #pragma config FPLLICLK = PLL_POSC #pragma config FPLLIDIV = DIV_3 #pragma config FPLL RNG = RANGE_5_10_MHZ #pragma config FPLLMULT = MUL_50 #pragma config FPLLODIV = DIV_2 #define SYSFREQ (200000000L)</pre> |

PIC32MZ Embedded Connectivity with Floating Point Unit (EF) Family

A.2 Analog-to-Digital Converter (ADC)

The PIC32MZ EF family of devices has a new Pipelined ADC module that replaces the 10-bit ADC module in PIC32MX5XX/6XX/7XX devices; therefore, the use of **Bold** type to show differences is *not* used in the following table. Note that not all register differences are described in this section; however, the key feature differences are listed in [Table A-3](#).

TABLE A-3: ADC DIFFERENCES

| PIC32MX5XX/6XX/7XX Feature | PIC32MZ EF Feature |
|---|--|
| Clock Selection and Operating Frequency (TAD) | |
| <p>On PIC32MX devices, the ADC clock was derived from either the FRC or from the PBCLK.</p> <p>ADRC (AD1CON3<15>) 1 = FRC clock 0 = Clock derived from Peripheral Bus Clock (PBCLK)</p> | <p>On PIC32MZ EF devices, the three possible sources of the ADC clock are FRC, REFCLKO3, and SYSCLK.</p> <p>ADCSEL<1:0> (ADCCON3<31:30>) 11 = FRC 10 = REFCLKO3 01 = SYSCLK 00 = Reserved</p> |
| <p>On PIC32MX devices, if the ADC clock was derived from the PBCLK, that frequency was divided further down, with a maximum divisor of 512, and a minimum divisor of two.</p> <p>ADCS<7:0> (AD1CON3<7:0>) 11111111 = 512 * TPB = TAD • • • 00000001 = 4 * TPB = TAD 00000000 = 2 * TPB = TAD</p> | <p>On PIC32MZ EF devices, any ADC clock source can be divided down separately for each dedicated ADC and the shared ADC, with a maximum divisor of 254. The input clock can also be fed directly to the ADC.</p> <p>ADCDIV<6:0> (ADCTIMEx<22:16>) ADCDIV<6:0> (ADCCON2<6:0>) 11111111 = 254 * TQ = TAD • • • 0000011 = 6 * TQ = TAD 0000010 = 4 * TQ = TAD 0000001 = 2 * TQ = TAD 0000000 = TQ = TAD</p> |
| Scan Trigger Source | |
| <p>On PIC32MX devices, there are four sources that can trigger a scan conversion in the ADC module: Auto, Timer3, INT0, and clearing the SAMP bit.</p> <p>SSRC<2:0> (AD1CON1<7:5>) 111 = Auto convert 110 = Reserved 101 = Reserved 100 = Reserved 011 = Reserved 010 = Timer3 period match 001 = Active transition on INT0 pin 000 = Clearing SAMP bit</p> | <p>On PIC32MZ EF devices, the list of sources for triggering a scan conversion has been expanded to include the comparators, Output Compare, and two additional Timers. In addition, trigger sources can be simulated by setting the RQCNVRT (ADCCON3<8>) bit.</p> <p>STRGSRC<4:0> (ADCCON1<20:16>) 11111 = Reserved • • • 01101 = Reserved 01100 = Comparator 2 COUT 01011 = Comparator 1 COUT 01010 = OCMP5 01001 = OCMP3 01000 = OCMP1 00111 = TMR5 match 00110 = TMR3 match 00101 = TMR1 match 00100 = INT0 00011 = Reserved 00010 = Global level software trigger (GLSWTRG) 00001 = Global software trigger (GSWTRG) 00000 = No trigger</p> |

PIC32MZ Embedded Connectivity with Floating Point Unit (EF) Family

TABLE A-3: ADC DIFFERENCES (CONTINUED)

| PIC32MX5XX/6XX/7XX Feature | PIC32MZ EF Feature |
|--|--|
| Output Format | |
| <p>On PIC32MX devices, the output format was decided for all ADC channels based on the setting of the FORM<2:0> bits.</p> <p>FORM<2:0> (AD1CON1<10:8>)</p> <p>011 = Signed Fractional 16-bit 010 = Fractional 16-bit 001 = Signed Integer 16-bit 000 = Integer 16-bit 111 = Signed Fractional 32-bit 110 = Fractional 32-bit 101 = Signed Integer 32-bit 100 = Integer 32-bit</p> | <p>On PIC32MZ EF devices, the FRACT bit determines whether fractional or integer format is used. Then, each input can have its own setting for input (differential or single-ended) and sign (signed or unsigned) using the DIFFx and SIGNx bits in the ADCIMODx registers.</p> <p>FRACT (ADCCON1<23>)</p> <p>1 = Fractional 0 = Integer</p> <p>DIFFx (ADCIMODy)</p> <p>1 = Channel x is using Differential mode 0 = Channel x is using Single-ended mode</p> <p>SIGNx (ADCMODy)</p> <p>1 = Channel x is using Signed Data mode 0 = Channel x is using Unsigned Data mode</p> |
| Interrupts | |
| <p>On PIC32MX devices, an interrupt is triggered from the ADC module when a certain number of conversions have taken place, irrespective of which channel was converted.</p> <p>SMPI<3:0> (AD1CON2<5:2>)</p> <p>1111 = Interrupt for each 16th sample/convert sequence 1110 = Interrupt for each 15th sample/convert sequence • • 0001 = Interrupt for each 2nd sample/convert sequence 0000 = Interrupt for each sample/convert sequence</p> | <p>On PIC32MZ EF devices, the ADC module can trigger an interrupt for each channel when it is converted. Use the Interrupt Controller bits, IEC1<31:27>, IEC2<31:0>, and IEC3<7:0>, to enable/disable them.</p> <p>In addition, the ADC support one global interrupt to indicate conversion on any number of channels.</p> <p>AGIENxx (ADCGIRQENx<y>)</p> <p>1 = Data ready event will generate a Global ADC interrupt 0 = No global interrupt</p> <p>In addition, interrupts can be generated for filter and comparator events.</p> |
| I/O Pin Analog Function Selection | |
| <p>On PIC32MX devices, the analog function of an I/O pin was determined by the PCFGx bit in the AD1PCFG register.</p> <p>PCFGx (AD1PCFG<x>)</p> <p>1 = Analog input pin in Digital mode 0 = Analog input pin in Analog mode</p> | <p>On PIC32MZ EF devices, the analog selection function has been moved into a separate register on each I/O port. Note that the sense of the bit is different.</p> <p>ANSxy (ANSELx<y>)</p> <p>1 = Analog input pin in Analog mode 0 = Analog input pin in Digital mode</p> |
| Electrical Specifications and Timing Requirements | |
| <p>Refer to “Section 31. Electrical Characteristics” in the PIC32MX5XX/6XX/7XX Data Sheet for ADC module specifications and timing requirements.</p> | <p>On PIC32MZ EF devices, the ADC module sampling and conversion time and other specifications have changed. Refer to 37.0 “Electrical Characteristics” for more information.</p> |

PIC32MZ Embedded Connectivity with Floating Point Unit (EF) Family

A.3 CPU

The CPU in the PIC32MZ EF family of devices has been changed to the MIPS32 M-Class MPU architecture. This CPU includes DSP ASE, internal data and instruction L1 caches, and a TLB-based MMU.

Table A-4 summarizes some of the key differences (indicated by **Bold** type) in the internal CPU registers.

TABLE A-4: CPU DIFFERENCES

| PIC32MX5XX/6XX/7XX Feature | PIC32MZ EF Feature |
|--|---|
| L1 Data and Instruction Cache and Prefetch Wait States | |
| <p>On PIC32MX devices, the cache was included in the prefetch module outside the CPU.</p> <p>PREFEN<1:0> (CHECON<5:4>) 11 = Enable predictive prefetch for both cacheable and non-cacheable regions 10 = Enable predictive prefetch for non-cacheable regions only 01 = Enable predictive prefetch for cacheable regions only 00 = Disable predictive prefetch</p> <p>DCSZ<1:0> (CHECON<9:8>) Changing these bits causes all lines to be reinitialized to the "invalid" state. 11 = Enable data caching with a size of 4 lines 10 = Enable data caching with a size of 2 lines 01 = Enable data caching with a size of 1 line 00 = Disable data caching</p> <p>CHECOH (CHECON<16>) 1 = Invalidate all data and instruction lines 0 = Invalidate all data and instruction lines that are not locked</p> | <p>On PIC32MZ EF devices, the CPU has a separate L1 instruction and data cache in the core. The PREFEN<1:0> bits still enable the prefetch module; however, the K0<2:0> bits in the CP0 registers controls the internal L1 cache for the designated regions.</p> <p>PREFEN<1:0> (PRECON<5:4>) 11 = Enable predictive prefetch for any address 10 = Enable predictive prefetch for CPU instructions and CPU data 01 = Enable predictive prefetch for CPU instructions only 00 = Disable predictive prefetch</p> <p>K0<2:0> (CP0 Reg 16, Select 0) 011 = Cacheable, non-coherent, write-back, write allocate 010 = Uncached 001 = Cacheable, non-coherent, write-through, write allocate 000 = Cacheable, non-coherent, write-through, no write allocate</p> |
| <p>PFMWS<2:0> (CHECON<2:0>) 111 = Seven Wait states 110 = Six Wait states 101 = Five Wait states 100 = Four Wait states 011 = Three Wait states 010 = Two Wait states (61-80 MHz) 001 = One Wait state (31-60 MHz) 000 = Zero Wait state (0-30 MHz)</p> | <p>The Program Flash Memory read wait state frequency points have changed in PIC32MZ EF devices. The register for accessing the PFMWS field has changed from CHECON to PRECON.</p> <p>PFMWS<2:0> (PRECON<2:0>) 111 = Seven Wait states • • • 011 = Three Wait states 010 = Two Wait states (133-200 MHz) 001 = One Wait state (66-133 MHz) 000 = Zero Wait states (0-66 MHz)</p> <p>Note: Wait states listed are for ECC enabled.</p> |
| Core Instruction Execution | |
| <p>On PIC32MX devices, the CPU can execute MIPS16e instructions and uses a 16-bit instruction set, which reduces memory size.</p> <p>MIPS16e®</p> | <p>On PIC32MZ EF devices, the CPU can operate a mode called microMIPS. microMIPS mode is an enhanced MIPS32® instruction set that uses both 16-bit and 32-bit opcodes. This mode of operation reduces memory size with minimum performance impact.</p> <p>microMIPS™ The BOOTISA (DEVCFG0<6>) Configuration bit controls the MIPS32 and microMIPS modes for boot and exception code. 1 = Boot code and Exception code is MIPS32® (ISAONEXC bit is set to '0' and the ISA<1:0> bits are set to '10' in the CP0 Config3 register) 0 = Boot code and Exception code is microMIPS™ (ISAONEXC bit is set to '1' and the ISA<1:0> bits are set to '11' in the CP0 Config3 register)</p> |

PIC32MZ Embedded Connectivity with Floating Point Unit (EF) Family

A.4 Resets

The PIC32MZ EF family of devices has updated the resets modules to incorporate the new handling of NMI resets from the WDT, DMT, and the FSCM. In addition, some bits have been moved, as summarized in [Table A-5](#).

TABLE A-5: RESET DIFFERENCES

| PIC32MX5XX/6XX/7XX Feature | PIC32MZ EF Feature |
|--|--|
| Power Reset | |
| VREGS (RCON<8>) 1 = Regulator is enabled and is on during Sleep mode 0 = Regulator is disabled and is off during Sleep mode | The VREGS bit, which controls whether the internal regulator is enabled in Sleep mode, has been moved from RCON in PIC32MX5XX/6XX/7XX devices to a new PWRCON register in PIC32MZ EF devices. VREGS (PWRCON<0>) 1 = Voltage regulator will remain active during Sleep 0 = Voltage regulator will go to Stand-by mode during Sleep |
| Watchdog Timer Reset | |
| On PIC32MX devices, a WDT expiration immediately triggers a device reset. WDT expiration immediately causes a device reset. | On PIC32MZ EF devices, the WDT expiration now causes a NMI. The WDTO bit in RNMICON indicates that the WDT caused the NMI. A new timer, NMICNT, runs when the WDT NMI is triggered, and if it expires, the device is reset. WDT expiration causes a NMI, which can then trigger the device reset. WDTO (RNMICON<24>) 1 = WDT time-out has occurred and caused a NMI 0 = WDT time-out has not occurred NMICNT<7:0> (RNMICON<7:0>) |

A.5 USB

The PIC32MZ EF family of devices has a new Hi-Speed USB module, which requires the updated USB stack from Microchip. In addition, the USB PLL was also updated. See [Section A.1 “Oscillator and PLL Configuration”](#) for more information and [Table A-6](#) for a list of additional differences.

TABLE A-6: USB DIFFERENCES

| PIC32MX5XX/6XX/7XX Feature | PIC32MZ EF Feature |
|---|---|
| Debug Mode | |
| On PIC32MX devices, when stopping on a breakpoint during debugging, the USB module can be configured to stop or continue execution from the Freeze Peripherals dialog in MPLAB X IDE. | On PIC32MZ EF devices, the USB module continues operating when stopping on a breakpoint during debugging. |
| VBUSON Pin | |
| PIC32MX devices feature a VBUSON pin for controlling the external transceiver power supply. | On PIC32MZ EF devices, the VBUSON pin is not available. A port pin can be used to achieve the same functionality. |

PIC32MZ Embedded Connectivity with Floating Point Unit (EF) Family

A.6 DMA

The DMA controller in PIC32MZ EF devices is similar to the DMA controller in PIC32MX5XX/6XX/7XX devices. New features include the extension of pattern matching to two by bytes and the addition of the optional Pattern Ignore mode. [Table A-7](#) lists differences (indicated by **Bold** type) that will affect software migration.

TABLE A-7: DMA DIFFERENCES

| PIC32MX5XX/6XX/7XX Feature | PIC32MZ EF Feature |
|---|---|
| Read/Write Status on Error | |
| RDWR (DMASTAT<3>) 1 = Last DMA bus access when an error was detected was a read 0 = Last DMA bus access when an error was detected was a write | The RDWR bit has moved from DMASTAT<3> in PIC32MX5XX/6XX/7XX devices to DMASTAT<31> in PIC32MZ EF devices. RDWR (DMASTAT<31>) 1 = Last DMA bus access when an error was detected was a read 0 = Last DMA bus access when an error was detected was a write |
| Source-to-Destination Transfer | |
| On PIC32MX devices, a DMA channel performs a read of the source data and completes the transfer of this data into the destination address before it is ready to read the next data from the source. | On PIC32MZ EF devices, the DMA implements a 4-deep queue for data transfers. A DMA channel reads the source data and places it into the queue, regardless of whether previous data in the queue has been delivered to the destination address. |

PIC32MZ Embedded Connectivity with Floating Point Unit (EF) Family

A.7 Interrupts and Exceptions

The key difference between Interrupt Controllers in PIC32MX5XX/6XX/7XX devices and PIC32MZ EF devices concerns vector spacing. Previous PIC32MX devices had fixed vector spacing, which is adjustable in set increments, and every interrupt had the same amount of space. PIC32MZ EF devices replace this with a variable offset spacing, where each interrupt has an offset register to determine where to begin execution.

In addition, the IFSx, IECx, and IPCx registers for old peripherals have shifted to different registers due to new peripherals. Please refer to [Section 7.0 “CPU Exceptions and Interrupt Controller”](#) to determine where the interrupts are now located.

[Table A-8](#) lists differences (indicated by **Bold** type) in the registers that will affect software migration.

TABLE A-8: INTERRUPT DIFFERENCES

| PIC32MX5XX/6XX/7XX Feature | PIC32MZ EF Feature |
|---|---|
| Vector Spacing | |
| <p>On PIC32MX devices, the vector spacing was determined by the VS field in the CPU core.</p> <p>VS<4:0> (IntCtl<9:5>: CP0 Register 12, Select 1) 10000 = 512-byte vector spacing 01000 = 256-byte vector spacing 00100 = 128-byte vector spacing 00010 = 64-byte vector spacing 00001 = 32-byte vector spacing 00000 = 0-byte vector spacing</p> | <p>On PIC32MZ EF devices, the vector spacing is variable and determined by the Interrupt controller. The VOFFx<17:1> bits in the OFFx register are set to the offset from EBASE where the interrupt service routine is located.</p> <p>VOFFx<17:1> (OFFx<17:1>) Interrupt Vector ‘x’ Address Offset bits</p> |
| Shadow Register Sets | |
| <p>On PIC32MX devices, there was one shadow register set which could be used during interrupt processing. Which interrupt priority could use the shadow register set was determined by the FSRSEL field in DEVCFG3 and SS0 on INTCON.</p> <p>FSRSSEL<2:0> (DEVCFG3<18:16>) 111 = Assign Interrupt Priority 7 to a shadow register set 110 = Assign Interrupt Priority 6 to a shadow register set • • • 001 = Assign Interrupt Priority 1 to a shadow register set 000 = All interrupt priorities are assigned to a shadow register set</p> <p>SS0 (INTCON<16>) 1 = Single vector is presented with a shadow register set 0 = Single vector is not presented with a shadow register set</p> | <p>On PIC32MZ EF devices, there are seven shadow register sets, and each priority level can be assigned a shadow register set to use via the PRIxSS<3:0> bits in the PRISS register. The SS0 bit is also moved to PRISS<0>.</p> <p>PRIxSS<3:0> PRISS<y:z> 1xxx = Reserved (by default, an interrupt with a priority level of x uses Shadow Set 0) 0111 = Interrupt with a priority level of x uses Shadow Set 7 0110 = Interrupt with a priority level of x uses Shadow Set 6 • • • 0001 = Interrupt with a priority level of x uses Shadow Set 1 0000 = Interrupt with a priority level of x uses Shadow Set 0</p> <p>SS0 (PRISS<0>) 1 = Single vector is presented with a shadow register set 0 = Single vector is not presented with a shadow register set</p> |
| Status | |
| <p>PIC32MX devices, the VEC<5:0> bits show which interrupt is being serviced.</p> <p>VEC<5:0> (INTSTAT<5:0>) 11111-00000 = The interrupt vector that is presented to the CPU</p> | <p>On PIC32MZ EF devices, the SIRQ<7:0> bits show the IRQ number of the interrupt last serviced.</p> <p>SIRQ<7:0> (INTSTAT<7:0>) 11111111-00000000 = The last interrupt request number serviced by the CPU</p> |

PIC32MZ Embedded Connectivity with Floating Point Unit (EF) Family

A.8 Flash Programming

The PIC32MZ EF family of devices incorporates a new Flash memory technology. Applications ported from PIC32MX5XX/6XX/7XX devices that take advantage of Run-time Self Programming will need to adjust the Flash programming steps to incorporate these changes.

Table A-9 lists the differences (indicated by **Bold** type) that will affect software migration.

TABLE A-9: FLASH PROGRAMMING DIFFERENCES

| PIC32MX5XX/6XX/7XX Feature | PIC32MZ EF Feature |
|---|---|
| Program Flash Write Protection | |
| <p>On PIC32MX devices, the Program Flash write-protect bits are part of the Flash Configuration words (DEVCFG0).</p> <p>PWP<7:0> (DEVCFG0<19:12>) 11111111 = Disabled 11111110 = 0xBD000FFF 11111101 = 0xBD001FFF 11111100 = 0xBD002FFF 11111011 = 0xBD003FFF 11111010 = 0xBD004FFF 11111001 = 0xBD005FFF 11111000 = 0xBD006FFF 11110111 = 0xBD007FFF 11110110 = 0xBD008FFF 11110101 = 0xBD009FFF 11110100 = 0xBD00AFFF 11110011 = 0xBD00BFFF 11110010 = 0xBD00CFFF 11110001 = 0xBD00DFFF 11110000 = 0xBD00EFFF 11101111 = 0xBD00FFFF • • • 01111111 = 0xBD07FFFF</p> | <p>On PIC32MZ EF devices, the write-protect register is contained separately as the NVMPWP register. It has been expanded to 24 bits, and now represents the address below, which all Flash memory is protected. Note that the lower 14 bits are forced to zero, so that all memory locations in the page are protected.</p> <p>PWP<23:0> (NVMPWP<23:0>) Physical memory below address 0x1Dxxxxxx is write protected, where 'xxxxxx' is specified by PWP<23:0>. When PWP<23:0> has a value of '0', write protection is disabled for the entire program Flash. If the specified address falls within the page, the entire page and all pages below the current page will be protected.</p> |
| Code Protection | |
| <p>On PIC32MX devices, code protection is enabled by the CP (DEVCFG<28>) bit.</p> | <p>On PIC32MZ EF devices, code protection is enabled by the CP (DEVCP0<28>) bit.</p> |
| Boot Flash Write Protection | |
| <p>On PIC32MX devices, Boot Flash write protection is enable by the BWP (DEVCFG<24>) bit and protects the entire Boot Flash memory.</p> | <p>On PIC32MZ EF devices, Boot Flash write protection is divided into pages and is enable by the LBWPx and UBWPx bits in the NVMBWP register.</p> |
| Low-Voltage Detect Status | |
| <p>LVDSTAT (NVMCON<11>) 1 = Low-voltage event is active 0 = Low-voltage event is not active</p> | <p>The LVDSTAT bit is not available in PIC32MZ EF devices.</p> |

PIC32MZ Embedded Connectivity with Floating Point Unit (EF) Family

TABLE A-9: FLASH PROGRAMMING DIFFERENCES (CONTINUED)

| PIC32MX5XX/6XX/7XX Feature | PIC32MZ EF Feature |
|---|---|
| Flash Programming | |
| <p>NVMOP<3:0> (NVMCON<3:0>)</p> <p>1111 = Reserved</p> <p>•</p> <p>•</p> <p>•</p> <p>0111 = Reserved</p> <p>0110 = No operation</p> <p>0101 = Program Flash (PFM) erase operation</p> <p>0100 = Page erase operation</p> <p>0011 = Row program operation</p> <p>0010 = No operation</p> <p>0001 = Word program operation</p> <p>0000 = No operation</p> | <p>The op codes for programming the Flash memory have been changed to accommodate the new quad-word programming and dual-panel features. The row size has changed to 2 KB (512 IW) from 128 IW. The page size has changed to 16 KB (4K IW) from 4 KB (1K IW). Note that the NVMOP register is now protected, and requires the WREN bit be set to enable modification.</p> <p>NVMOP<3:0> (NVMCON<3:0>)</p> <p>1111 = Reserved</p> <p>•</p> <p>•</p> <p>•</p> <p>1000 = Reserved</p> <p>0111 = Program erase operation</p> <p>0110 = Upper program Flash memory erase operation</p> <p>0101 = Lower program Flash memory erase operation</p> <p>0100 = Page erase operation</p> <p>0011 = Row program operation</p> <p>0010 = Quad Word (128-bit) program operation</p> <p>0001 = Word program operation</p> <p>0000 = No operation</p> |
| <p>PIC32MX devices feature a single NVMDATA register for word programming.</p> <p>NVMDATA</p> | <p>On PIC32MZ EF devices, to support quad word programming, the NVMDATA register has been expanded to four words.</p> <p>NVMDATA_x, where 'x' = 0 through 3</p> |
| Flash Endurance and Retention | |
| <p>PIC32MX devices support Flash endurance and retention of up to 20K E/W cycles and 20 years.</p> | <p>On PIC32MZ EF devices, ECC must be enabled to support the same endurance and retention as PIC32MX devices.</p> |
| Configuration Words | |
| <p>On PIC32MX devices, Configuration Words can be programmed with Word or Row program operation.</p> | <p>On PIC32MZ EF devices, all Configuration Words must be programmed with Quad Word operation.</p> |
| Configuration Words Reserved Bit | |
| <p>On PIC32MX devices, the DEVCFG0<15> bit is Reserved and must be programmed to '0'.</p> | <p>On PIC32MZ EF devices, this bit is DEVSIGN0<31>.</p> |

PIC32MZ Embedded Connectivity with Floating Point Unit (EF) Family

A.9 Other Peripherals and Features

Most of the remaining peripherals on PIC32MZ EF devices act identical to their counterparts on PIC32MX-5XX/6XX/7XX devices. The main differences have to do with handling the increased peripheral bus clock speed and additional clock sources.

Table A-10 lists the differences (indicated by **Bold** type) that will affect software and hardware migration.

TABLE A-10: PERIPHERAL DIFFERENCES

| PIC32MX5XX/6XX/7XX Feature | PIC32MZ EF Feature |
|--|---|
| I²C™ | |
| On PIC32MX devices, all pins are 5V-tolerant. | On PIC32MZ EF devices, the I2C4 port uses non-5V tolerant pins, and will have different VOL/VOH specifications. |
| I2CxBRG<11:0> | The Baud Rate Generator register has been expanded from 12 bits to 16 bits. I2CxBRG< 15:0 > |
| Watchdog Timer | |
| Clearing the Watchdog Timer on PIC32MX5XX/6XX/7XX devices required writing a '1' to the WDTCLR bit. | On PIC32MZ EF devices, the WDTCLR bit has been replaced with the 16-bit WDTCLRKEY, which must be written with a specific value (0x5743) to clear the Watchdog Timer. In addition, the WDTSPGM (DEVCFG1<21>) bit is used to control operation of the Watchdog Timer during Flash programming. |
| WDTCLR (WDTCON<0>) | WDTCLRKEY<15:0> (WDTCON<31:16>) |
| RTCC | |
| On PIC32MX devices, the output of the RTCC pin was selected between the Seconds Clock or the Alarm Pulse. RTCSECSEL (RTCCON<7>) 1 = RTCC Seconds Clock is selected for the RTCC pin 0 = RTCC Alarm Pulse is selected for the RTCC pin | On PIC32MZ EF devices, the RTCC Clock is added as an option. RTCSECSEL has been renamed RTCOUTSEL and expanded to two bits. RTCOUTSEL<1:0> (RTCCON<8:7>) 11 = Reserved 10 = RTCC Clock is presented on the RTCC pin 01 = Seconds Clock is presented on the RTCC pin 00 = Alarm Pulse is presented on the RTCC pin when the alarm interrupt is triggered |
| On PIC32MX devices, the Secondary Oscillator (SOSC) serves as the input clock for the RTCC module. | On PIC32MZ EF devices, an additional clock source, LPRC, is available as a choice for the input clock. RTCCLKSEL<1:0> (RTCCON<10:9>) 11 = Reserved 10 = Reserved 01 = RTCC uses the external 32.768 kHz Sosc 00 = RTCC uses the internal 32 kHz oscillator (LPRC) |

PIC32MZ Embedded Connectivity with Floating Point Unit (EF) Family

TABLE A-10: PERIPHERAL DIFFERENCES (CONTINUED)

| PIC32MX5XX/6XX/7XX Feature | PIC32MZ EF Feature |
|--|---|
| Ethernet | |
| <p>CLKSEL<3:0> (EMAC1MCFG<5:2>)</p> <p>1000 = SYSCLK divided by 40 0111 = SYSCLK divided by 28 0110 = SYSCLK divided by 20 0101 = SYSCLK divided by 14 0100 = SYSCLK divided by 10 0011 = SYSCLK divided by 8 0010 = SYSCLK divided by 6 000x = SYSCLK divided by 4</p> | <p>On PIC32MZ EF devices, the input clock divider for the Ethernet module has expanded options to accommodate the faster peripheral bus clock.</p> <p>CLKSEL<3:0> (EMAC1MCFG<5:2>)</p> <p>1010 = PBCLK5 divided by 50 1001 = PBCLK5 divided by 48 1000 = PBCLK5 divided by 40 0111 = PBCLK5 divided by 28 0110 = PBCLK5 divided by 20 0101 = PBCLK5 divided by 14 0100 = PBCLK5 divided by 10 0011 = PBCLK5 divided by 8 0010 = PBCLK5 divided by 6 000x = PBCLK5 divided by 4</p> |
| Comparator/Comparator Voltage Reference | |
| <p>On PIC32MX devices, it was possible to select the VREF+ pin as the output to the CVREFOUT pin.</p> <p>VREFSEL (CVRCON<10>)</p> <p>1 = CVREF = VREF+ 0 = CVREF is generated by the resistor network</p> | <p>On PIC32MZ EF devices, the CVREFOUT pin must come from the resistor network.</p> <p>This bit is not available.</p> |
| <p>On PIC32MX devices, the internal voltage reference (IVREF) could be chosen by the BGSEL<1:0> bits.</p> <p>BGSEL<1:0> (CVRCON<9:8>)</p> <p>11 = IVREF = VREF+ 10 = Reserved 01 = IVREF = 0.6V (nominal, default) 00 = IVREF = 1.2V (nominal)</p> | <p>On PIC32MZ EF devices, IVREF is fixed and cannot be changed.</p> <p>These bits are not available.</p> |
| Change Notification | |
| <p>On PIC32MX devices, Change Notification is controlled by the CNCON, CNEN, and CNPUE registers.</p> | <p>On PIC32MZ EF devices, Change Notification functionality has been relocated into each I/O port and is controlled by the CNPUx, CNPDx, CNCONx, CNENx, and CNSTATx registers.</p> |
| System Bus | |
| <p>On PIC32MX devices, the System Bus registers can be used to configure RAM memory for data and program memory partitions, cacheability of Flash memory, and RAM Wait states. These registers are: BMXCON, BMXDKPBA, BMXDUDBA, BMXDUPBA, BMXPUPBA, BMXDRMSZ, BMXPFMSZ, and BMXBOOTSZ.</p> | <p>On PIC32MZ EF devices, a new System Bus is utilized that supports using RAM memory for program or data without the need for special configuration. Therefore, no special registers are associated with the System Bus to configure these features.</p> |
| <p>On PIC32MX devices, various arbitration modes are used as initiators on the System Bus. These modes can be selected by the BMXARB<2:0> (BMXCON<2:0>) bits.</p> | <p>On PIC32MZ EF devices, a new arbitration scheme has been implemented on the System Bus. All initiators use the Least Recently Served (LRS) scheme, with the exception of the DMA, CPU, and the Flash Controller.</p> <p>The Flash Controller always has High priority over LRS initiators.</p> <p>The DMA and CPU (when servicing an interrupt) can be selected to have LRS or High priority using the DMAPRI (CFGCON<25>) and CPUPRI (CFGCON<24>) bits.</p> |

PIC32MZ Embedded Connectivity with Floating Point Unit (EF) Family

A.10 Package Differences

In general, PIC32MZ EF devices are mostly pin compatible with PIC32MX5XX/6XX/7XX devices; however, some pins are not. In particular, the VDD and VSS pins have been added and moved to different pins. In addition, I/O functions that were on fixed pins now will largely be on remappable pins.

TABLE A-11: PACKAGE DIFFERENCES

| PIC32MX5XX/6XX/7XX Feature | PIC32MZ EF Feature |
|---|--|
| VCAP Pin | |
| On PIC32MX devices, an external capacitor is required between a VCAP pin and GND, which provides a filtering capacitor for the internal voltage regulator. A low-ESR capacitor (typically 10 μ F) is required on the VCAP pin. | On PIC32MZ EF devices, this requirement has been removed. No VCAP pin. |
| VDD and VSS Pins | |
| VDD on 64-pin packages: 10, 26, 38, 57 VDD on 100-pin packages: 2, 16, 37, 46, 62, 86 | There are more VDD pins on PIC32MZ EF devices, and many are located on different pins. VDD on 64-pin packages: 8, 26, 39, 54, 60 VDD on 100-pin packages: 14, 37, 46, 62, 74, 83, 93 |
| VSS on 64-pin packages: 9, 25, 41 VSS on 100-pin packages: 15, 36, 45, 65, 75 | There are more VSS pins on PIC32MZ EF devices, and many are located on different pins. VSS on 64-pin packages: 7, 25, 35, 40, 55, 59 VSS on 100-pin packages: 13, 36, 45, 53, 63, 75, 84, 92 |
| PPS I/O Pins | |
| All peripheral functions are fixed as to what pin upon which they operate. | Peripheral functions on PIC32MZ EF devices are now routed through a PPS module, which routes the signals to the desired pins. When migrating software, it is necessary to initialize the PPS I/O functions in order to get the signal to and from the correct pin. PPS functionality for the following peripherals: <ul style="list-style-type: none"> • CAN • UART • SPI (except SCK) • Input Capture • Output Compare • External Interrupt (except INT0) • Timer Clocks (except Timer1) • Reference Clocks (except REFCLK2) |

PIC32MZ Embedded Connectivity with Floating Point Unit (EF) Family

APPENDIX B: MIGRATING FROM PIC32MZ EC TO PIC32MZ EF

This appendix provides an overview of considerations for migrating from PIC32MZ EC devices to the PIC32MZ EF family of devices. The code developed for PIC32MZ EC devices can be ported to PIC32MZ EF devices after making the appropriate changes outlined in the following sections.

The PIC32MZ EF devices are similar to PIC32MZ EC devices, with many feature improvements and new capabilities.

B.1 Oscillator and PLL Configuration

A number of new features have been added to the oscillator and PLL to enhance their ability to work with crystals and to change frequencies.

[Table B-1](#) summarizes the differences (indicated by **Bold** type) between the family differences for the oscillator.

TABLE B-1: OSCILLATOR DIFFERENCES

| PIC32MZ EC Feature | PIC32MZ EF Feature |
|---|--|
| Primary Oscillator Crystal Power | |
| On PIC32MZ EC devices, the crystal HS Posc mode is only functional with crystals that have certain characteristics, such as very low ESR. | On PIC32MZ EF devices, some DEVCFG0 bits have been added to allow control over the strength of the oscillator and to add a kick start boost. POSCBOOST (DEVCFG0<21>) 1 = Boost the kick start of the oscillator 0 = Normal start of the oscillator POSCGAIN<1:0> (DEVCFG0<20:19>) 11 = 2x gain setting 10 = 1.5x gain setting 01 = 0.5x gain setting 00 = 1x gain setting Note that the default for POSCGAIN (2x gain setting) may over-drive crystals and shorten their life. It is the responsibility of the designer to ensure crystals are operated properly. |
| Secondary Oscillator Crystal Power | |
| On PIC32MZ EC devices, the Secondary Oscillator (SOSC) is not functional. | On PIC32MZ EF devices, the Secondary Oscillator is now functional, and provides similar strength and kick start boost features as the POSC. SOSCBOST (DEVCFG0<18>) 1 = Boost the kick start of the oscillator 0 = Normal start of the oscillator SOSCGAIN<1:0> (DEVCFG0<17:16>) 11 = 2x gain setting 10 = 1.5x gain setting 01 = 0.5x gain setting 00 = 1x gain setting Note that the default for SOSCGAIN (2x gain setting) may over-drive crystals and shorten their life. It is the responsibility of the designer to ensure crystals are operated properly. |
| Clock Status Bits | |
| On PIC32MZ EC devices, the SOSCRDY bit (OSCCON<22>) indicates when the Secondary Oscillator is ready. There are no indications of other oscillator status. | A new register, CLKSTAT, has been added, which includes the SOSCRDY bit (CLKSTAT<4>). In addition, new status bits are available: <ul style="list-style-type: none"> • LPRCRDY (CLKSTAT<5>) • POSCRDY (CLKSTAT<2>) • DIVSPLLRDY (CLKSTAT<1>) • FRCRDY (CLKSTAT<0>) |
| Clock Switching | |
| On PIC32MZ EC devices, clock switches occur as soon as the switch command is issued. Also, the only clock sources that can be divided are the output of the PLL, and the FRC. | To reduce power spikes during clock switches, PIC32MZ EF devices add a clock slewing feature, so that clock switches can be controlled in their rate and size. The SLEWCON register controls this feature. The SLEWCON register also features a SYSCLK divider, so that all of the possible clock sources may be divided further as needed. |

PIC32MZ Embedded Connectivity with Floating Point Unit (EF) Family

B.2 Analog-to-Digital Converter (ADC)

The PIC32MZ EC family features a Pipelined ADC module, while the PIC32MZ EF family of devices has an entirely new 12-bit High-Speed SAR ADC module. Nearly all registers in this new ADC module differ from the registers in PIC32MZ EC devices. Due to this difference, code will not port from PIC32MZ EC devices to PIC32MZ EF devices. [Table B-2](#) lists some of the differences in registers to note to adapt code as quickly as possible.

TABLE B-2: ADC DIFFERENCES

| PIC32MZ EC Feature | PIC32MZ EF Feature |
|---|---|
| Clock Selection and Operating Frequency (TAD) | |
| <p>On PIC32MZ EC devices, there are three possible sources of the ADC clock: FRC, REFCLKO3, and SYSCLK.</p> <p>ADCSEL<1:0> (AD1CON1<9:8>) 11 = FRC 10 = REFCLKO3 01 = SYSCLK 00 = Reserved</p> | <p>On PIC32MZ EF devices, there are four sources for the ADC clock. In addition to the ones for PIC32MZ EC, PBCLK4 is added as a source. Also, the clock source selection is in a different register.</p> <p>ADCSEL<1:0> (ADCCON3<31:30>) 11 = FRC 10 = REFCLKO3 01 = SYSCLK 00 = PBCLK4</p> |
| Scan Trigger Sources | |
| <p>On PIC32MZ EC devices, there are 10 available trigger sources for starting ADC sampling and conversion.</p> <p>STRGSRC<4:0> (AD1CON1<26:22>) 11111 = Reserved • • • 01101 = Reserved 01100 = Comparator 2 COUT 01011 = Comparator 1 COUT 01010 = OCMP5 01001 = OCMP3 01000 = OCMP1 00111 = TMR5 match 00110 = TMR3 match 00101 = TMR1 match 00100 = INTO 00011 = Reserved 00010 = Reserved 00001 = Global Software Trigger (GSWTRG) 00000 = No trigger</p> | <p>On PIC32MZ EF devices, two new sources have been added. One is a shared trigger source (STRIG). The other is a Global Level Software Trigger (GLSWTRG). With the GLSWTRG, the conversions continue until the bit is cleared in software.</p> <p>TRGSRC<4:0> (ADCTRGx<y:z>) 11111 = Reserved • • • 01101 = Reserved 01100 = Comparator 2 COUT 01011 = Comparator 1 COUT 01010 = OCMP5 01001 = OCMP3 01000 = OCMP1 00111 = TMR5 match 00110 = TMR3 match 00101 = TMR1 match 00100 = INTO 00011 = STRIG 00010 = Global Level Software Trigger (GLSWTRG) 00001 = Global Software Trigger (GSWTRG) 00000 = No trigger</p> |
| ADC Calibration | |
| <p>PIC32MZ EC devices require calibration values be copied into the AD1CALx registers before turning on the ADC. These values come from the DEVADCx registers.</p> | <p>PIC32MZ EF devices do not require this step, and the corresponding registers are not available.</p> |
| Debug Mode | |
| <p>On PIC32MZ EC devices, the ADC module continues operating when stopping on a breakpoint during debugging.</p> | <p>On PIC32MZ EF devices, the ADC module will stop during debugging when stopping on a breakpoint.</p> |
| Electrical Specifications and Timing Requirements | |
| <p>Refer to the “Electrical Characteristics” chapter in the PIC32MZ EC data sheet for ADC module specifications and timing requirements.</p> | <p>On PIC32MZ EF devices, the ADC module sampling and conversion time and other specifications have changed. Refer to 37.0 “Electrical Characteristics” for more information.</p> |

PIC32MZ Embedded Connectivity with Floating Point Unit (EF) Family

B.3 CPU

The CPU in PIC32MZ EC devices is the microAptiv™ MPU architecture. The CPU in the PIC32MZ EF devices is the Series 5 Warrior M-Class M5150 MPU architecture. Most PIC32MZ EF M-Class core features are identical to the microAptiv™ core in PIC32MZ EC devices. The main differences are that in PIC32MZ EF devices, a floating-point unit (FPU) is included for improved math performance, and PC Sampling for performance measurement.

B.4 System Bus

The system bus on PIC32MZ EF devices is similar to the system bus on PIC32MZ EC devices. There are two key differences listed in [Table B-3](#).

TABLE B-3: SYSTEM BUS DIFFERENCES

| PIC32MZ EC Feature | PIC32MZ EF Feature |
|---|---|
| Permission Groups during NMI | |
| On PIC32MZ EC devices, the permission group in which the CPU is part of is lost during NMI handling, and must be manually restored. | On PIC32MZ EF devices, the prior permission group is preserved, and is restored when the CPU returns from the NMI handler. |
| DMA Access | |
| The DMA can access the peripheral registers on Peripheral Bus 1. | On PIC32MZ EF devices, the DMA no longer has access to registers on Peripheral Bus 1. Refer to Table 4-4 for details on which peripherals are now excluded. |

B.5 Flash Controller

The Flash controller on PIC32MZ EF devices adds the ability both to control boot Flash aliasing, and for locking the current swap settings. [Table B-4](#) lists these differences.

TABLE B-4: FLASH CONTROLLER DIFFERENCES

| PIC32MZ EC Feature | PIC32MZ EF Feature |
|---|--|
| Boot Flash Aliasing | |
| On PIC32MZ EC devices, boot flash aliasing is done through the DEVSEQ0 register, but no further changes are possible without rebooting the processor. | On PIC32MZ EF devices, the initial boot flash aliasing is still determined by the DEVSEQ0 register, but the BFSWAP bit (NVMCON<6>) reflects the state of the aliasing, and can be modified to change it during run-time. BFSWAP (NVMCON<6>) 1 = Boot Flash Bank 2 is mapped to the lower boot alias, and Boot Flash bank 1 is mapped to the upper boot alias 0 = Boot Flash Bank 1 is mapped to the lower boot alias, and Boot Flash Bank 2 is mapped to the upper boot alias |
| PFM and BFM Swap Locking | |
| On PIC32MZ EC devices, the swapping of PFM is always available. | On PIC32MZ EF devices, a new control, SWAPLOCK<1:0> (NVMCON2<7:6>) allows the locking of PFSWAP and BFSWAP bits, and can restrict any further changes. SWAPLOCK<1:0> (NVMCON2<7:6>) 11 = PFSWAP and BFSWAP are not writable and SWAPLOCK is not writable 10 = PFSWAP and BFSWAP are not writable and SWAPLOCK is writable 01 = PFSWAP and BFSWAP are not writable and SWAPLOCK is writable 00 = PFSWAP and BFSWAP are writable and SWAPLOCK is writable |

PIC32MZ Embedded Connectivity with Floating Point Unit (EF) Family

B.6 Resets

On PIC32MZ EF devices, the Reset module adds eight bits to the NMICNT field to make the time-out period before device Reset longer, as described in [Table B-5](#).

TABLE B-5: RESETS DIFFERENCES

| PIC32MZ EC Feature | PIC32MZ EF Feature |
|--|--|
| Countdown to Reset During NMIs | |
| On PIC32MZ EC devices, the NMICNT<7:0> field is eight bits long, giving a maximum of 256 instructions before the device Reset. | On PIC32MZ EF devices, the NMICNT<15:0> field is now 16 bits long, giving a longer period of time (up to 65,536 instructions) prior to a device Reset. |

B.7 USB

On PIC32MZ EF devices, a new USBCRCON register has been added to assist in controlling the reset of the USB module, and triggering interrupts based on VBUS voltage levels. This register also overcomes an errata on PIC32MZ EC devices that requires a three second start-up on the USB module.

B.8 I/O Ports

On PIC32MZ EF devices, many of the I/O pins now feature slew rate control bits to control how fast the pin makes a low-to-high or high-to-low transition. The Change Notification feature has also been enhanced to allow detection of level events in addition to edge detection.

B.9 Watchdog Timer

PIC32MZ EF devices use a new Watchdog Timer, although the overall control through the DEVCFGx words remains identical to that of PIC32MZ EC devices. [Table B-6](#) lists two more changes, as well.

TABLE B-6: WATCHDOG TIMER DIFFERENCES

| PIC32MZ EC Feature | PIC32MZ EF Feature |
|--|---|
| Watchdog Timer Postscaler | |
| On PIC32MZ EC devices, the SWDTPS<4:0> bits (WDTCON<6:2>) reflect the postscaler setting for the Watchdog Timer. | On PIC32MZ EF devices, the field has been changed to the RUNDIV<4:0> bits (WDTCON<12:8>). |
| Watchdog Windowed Mode | |
| On PIC32MZ EC devices, WDTWINEN is at bit position 1 (WDTCON<1>). | On PIC32MZ EF devices, WDTWINEN is now at bit position 0 (WDTCON<0>). |

PIC32MZ Embedded Connectivity with Floating Point Unit (EF) Family

B.10 Serial Quad Interface (SQI)

On PIC32MZ EF devices, the SQI module supports double-data-rate (DDR) memories. Refer to [20.0 “Serial Quad Interface \(SQI\)”](#) and [Section 46. “Serial Quad Interface \(SQI\)”](#) (DS60001128) for information.

B.11 PMP

On PIC32MZ EF devices, the PMP features the ability to buffer reads and writes in both directions, and can read and write from different addresses. Refer to [23.0 “Parallel Master Port \(PMP\)”](#) and [Section 43. “Parallel Master Port”](#) (DS60001346) for information.

B.12 Crypto Engine

[Table B-7](#) lists the changes available for the Crypto Engine.

TABLE B-7: CRYPTO DIFFERENCES

| PIC32MZ EC Feature | PIC32MZ EF Feature |
|---|--|
| Output Data Format | |
| On PIC32MZ EC devices, the output of the Crypto Engine is always in big-endian format, usually requiring a software (or DMA) solution to put the data into little-endian format, which the core handles natively. | On PIC32MZ EF devices, the SWAPOEN bit (CECON<7>) has been added to control output byte swapping. This bit, when enabled, will byte-swap the output. |

B.13 Device Configuration and Control

A number of enhancements have been added to the PIC32MZ EF devices that allow greater control and flexibility on the device. Some bit fields have also changed location. [Table B-8](#) lists these changes.

TABLE B-8: DEVICE CONFIGURATION AND CONTROL DIFFERENCES

| PIC32MZ EC Feature | PIC32MZ EF Feature |
|---|--|
| MCLR Pin Configuration | |
| On PIC32MZ EC devices, the MCLR pin always generate a system reset. | On PIC32MZ EF devices, the $\overline{\text{MCLR}}$ pin can now be configured to generate either a system Reset or an emulated POR Reset. SMCLR (DEVCFG0<15>) 1 = MCLR pin generates a normal system Reset 0 = MCLR pin generates an emulated POR Reset |
| I/O Analog Charge Pump | |
| Low VDD environments cause attenuation of analog inputs. | A new bit enables an I/O charge pump, which improves analog performance when operating at lower VDD. IOANCPEN (CFGCON<7>) 1 = Charge pump is enabled 0 = Charge pump is disabled |
| EBI Ready Pin Control | |
| EBIRDYINV<3:1> (CFGEBIC<30:28>) EBIRDYEN<3:1> (CFGEBIC<26:24>) | The EBIRDY control bits have been moved. EBIRDYINV<3:1> (CFGEBIC<31:29>) EBIRDYEN<3:1> (CFGEBIC<27:25>) |

APPENDIX C: REVISION HISTORY

Revision A (January 2015)

This is the initial released version of the document.

Revision B (July 2015)

The document status was updated from Advance Information to Preliminary.

The revision includes the following major changes, which are referenced by their respective chapter in [Table C-1](#).

In addition, minor updates to text and formatting were incorporated throughout the document.

TABLE C-1: MAJOR SECTION UPDATES

| Section Name | Update Description |
|--|---|
| 32-bit MCUs (up to 2 MB Live-Update Flash and 512 KB SRAM) with FPU, Audio and Graphics Interfaces, HS USB, Ethernet, and Advanced Analog | The Operating Conditions were updated to: 2.1V to 3.6V. |
| 4.0 “Memory Organization” | Legal information on the System Bus was added (see 4.2 “System Bus Arbitration”). |
| 5.0 “Flash Program Memory” | The BOOTSWAP bit in the NVMCON register was changed to: BFSWAP (see Register 5-1). |
| 6.0 “Resets” | The NVMLTA bit was removed from the RCON register (see Register 6-1). The GNMI bit was added to the RNMICON register (see Register 6-3). |
| 7.0 “CPU Exceptions and Interrupt Controller” | The ADC FIFO Data Ready Interrupt, IRQ 45, was added (see Table 7-2). ADC FIFO bits were added, and Note 7 regarding devices without a Crypto module was added to the Interrupt Register Map (see Table 7-3). The NMIKEY<7:0> bits were added to the INTCON register (see Register 7-1). |
| 8.0 “Oscillator Configuration” | The SPLLRDY bit was removed and the SPLLDIVRDY bit was added to the CLKSTAT register (see Register 8-8). |
| 11.0 “Hi-Speed USB with On-The-Go (OTG)” | The VBUSIE and VBUSIF bits were changed to: VBUSERRIE and VBUSERRIF, respectively in the USBCSR2 register (see Register 11-3). |
| 15.0 “Deadman Timer (DMT)” | The POR values were updated for the PSCNT<4:0> bits in the Post Status Configure DMT Count Status register (see Register 15-6). The POR values were updated for the PSINTV<2:0> bits in the Post Status Configure DMT Interval Status register (see Register 15-7). |
| 16.0 “Watchdog Timer (WDT)” | The WDTCON register was updated (see Register 16-1). |
| 23.0 “Parallel Master Port (PMP)” | The PMDOUT, PMDIN, and PMRDIN registers were added (see Register 23-4 , Register 23-4 , and Register 23-10). The PMADDR, PMWADDR, and PMRADDR registers were updated (see Register 23-3 , Register 23-8 , and Register 23-9). The PMRDATA register was removed. |
| 24.0 “External Bus Interface (EBI)” | Reset values for the EBIMSK2, EBIMSK3, EBISMT0-EBISMT2, and EBIFTRPD registers were updated in the EBI Register Map (see Table 24-2). POR value changes were implemented to the EBI Static Memory Timing Register (see Register 24-3). |

PIC32MZ Embedded Connectivity with Floating Point Unit (EF) Family

TABLE C-1: MAJOR SECTION UPDATES (CONTINUED)

| Section Name | Update Description |
|---|---|
| 27.0 “Random Number Generator (RNG)” | The TRNGMODE bit was added to the RNGCON register (see Register 27-2). |
| 28.0 “12-bit High-Speed Successive Approximation Register (SAR) Analog-to-Digital Converter (ADC)” | <p>The S&H Block Diagram was updated (see Figure 28-2).</p> <p>The registers, ADCTRG4 through ADCTRG8, were removed.</p> <p>The bit value definitions for the ADCSEL<1:0> and CONCLKDIV<5:0> bits in the ADCCON3 register were updated (see Register 28-3).</p> <p>The bit names in the ADC Status registers (Register 28-12 and Register 28-13) were updated to match the names in the SFR summary table.</p> <p>The ADCTRGSNS register was updated (see Register 28-26).</p> <p>The POR values were changed in the ADC System Configuration registers (see Register 28-34 and Register 28-35).</p> |
| 34.0 “Special Features” | The FDBGWP bit was removed from the DEVCFG0/ADEVCFG0 registers (see Register 34-3). |
| 37.0 “Electrical Characteristics” | <p>V-Temp ($-40^{\circ}\text{C} \leq \text{TA} \leq +105^{\circ}\text{C}$) information was removed from all tables.</p> <p>The operating conditions voltage range was updated in the Absolute Maximum Ratings and in all tables to: 2.1V to 3.6V.</p> <p>Notes on Maximum value operating conditions were added to the Operating, Idle, and Power-Down Current tables (see Table 37-6, Table 37-7, and Table 37-8, respectively).</p> <p>The conditions for System Timing Requirement parameters OS55a and OS55b were updated (see Table 37-18).</p> <p>The Internal FRC Accuracy specifications were updated (see Table 37-20).</p> <p>The Internal LPRC Accuracy specifications were updated (see Table 37-21).</p> <p>The ADC Module Specifications were updated (see Table 37-38).</p> <p>The Analog-to-Digital Conversion Timing Requirements were updated (see Table 37-39).</p> |
| Appendix B: “Migrating from PIC32MZ EC to PIC32MZ EF” | This appendix was added, which provides an overview of considerations for migrating from PIC32MZ EC devices to the PIC32MZ EF family of devices. |
| Product Identification System | V-Temp ($-40^{\circ}\text{C} \leq \text{TA} \leq +105^{\circ}\text{C}$) information was removed. |

PIC32MZ Embedded Connectivity with Floating Point Unit (EF) Family

INDEX

Symbols

| | |
|-------------|--------|
| ('y' = 0-8) | 96, 98 |
| *'y' = 0-8) | 97 |

A

| | |
|---|-----|
| AC Characteristics | 624 |
| ADC Specifications | 650 |
| Analog-to-Digital Conversion Requirements | 651 |
| EJTAG Timing Requirements | 662 |
| Ethernet | 658 |
| Internal BFRC Accuracy | 627 |
| Internal FRC Accuracy | 627 |
| Internal LPRC Accuracy | 627 |
| Parallel Master Port Read Requirements | 655 |
| Parallel Master Port Write | 656 |
| Parallel Master Port Write Requirements | 656 |
| Parallel Slave Port Requirements | 654 |
| PLL Clock Timing | 626 |
| USB OTG Electrical Specifications | 657 |
| Assembler | |
| MPASM Assembler | 608 |

B

| | |
|--|-----|
| Block Diagrams | |
| Comparator I/O Operating Modes | 569 |
| Comparator Voltage Reference | 573 |
| CPU | 44 |
| Crypto Engine | 403 |
| DMA | 175 |
| EBI System | 385 |
| Ethernet Controller | 525 |
| I2C Circuit | 356 |
| Input Capture | 307 |
| Interrupt Controller | 115 |
| JTAG Programming, Debugging and Trace Ports | 603 |
| Output Compare Module | 311 |
| PIC32 CAN Module | 487 |
| PMP Pinout and Connections to External Devices | 371 |
| Prefetch Module | 171 |
| Random Number Generator (RNG) | 423 |
| RTCC | 393 |
| Serial Quad Interface (SQI) | 327 |
| SPI/I2S Module | 317 |
| System Reset | 109 |
| Timer1 | 285 |
| Timer2-Timer9 (16-Bit) | 289 |
| Typical Multiplexed Port Structure | 249 |
| UART | 363 |
| WDT | 303 |
| Brown-out Reset (BOR) and On-Chip Voltage Regulator | 603 |

C

| | |
|--------------------------------------|-----|
| C Compilers | |
| MPLAB | 608 |
| Comparator | |
| Specifications | 623 |
| Comparator Module | 569 |
| Comparator Voltage Reference (CVref) | 573 |
| Configuration Bits | 583 |
| Configuring Analog Port Pins | 250 |
| Controller Area Network (CAN) | 487 |

CPU

| | |
|--------------------------------------|-----|
| Architecture Overview | 45 |
| Coprocessor 0 Registers | 46 |
| Core Exception Types | 116 |
| EJTAG Debug Support | 50 |
| Power Management | 49 |
| CPU Module | 43 |
| Crypto | |
| Buffer Descriptors | 414 |
| Format of BD_CTRL | 415 |
| Format of BD_DSTADDR | 416 |
| Format of BD_ENC_OFF | 417 |
| Format of BD_MSG_LEN | 417 |
| Format of BD_NXTADDR | 416 |
| Format of BD_SADDR | 415 |
| Format of BD_SRCADDR | 416 |
| Format of BD_UPDPTR | 417 |
| Format of SA_CTRL | 421 |
| Security Association Structure | 418 |
| Crypto Engine | 403 |
| Customer Change Notification Service | 717 |
| Customer Notification Service | 717 |
| Customer Support | 717 |

D

| | |
|--|----------|
| DC Characteristics | 612 |
| I/O Pin Input Specifications | 617, 618 |
| I/O Pin Output Specifications | 619 |
| Idle Current (IDLE) | 615 |
| Power-Down Current (IPD) | 616 |
| Program Flash Memory Wait States | 622 |
| Program Memory | 622 |
| Temperature and Voltage Specifications | 613 |
| Development Support | 607 |
| Direct Memory Access (DMA) Controller | 175 |

E

| | |
|-----------------------------------|-----|
| Electrical Characteristics | 611 |
| Errata | 12 |
| Ethernet Controller | 525 |
| External Bus Interface (EBI) | 385 |
| External Clock | |
| Timer1 Timing Requirements | 633 |
| Timer2-Timer9 Timing Requirements | 634 |
| Timing Requirements | 625 |

F

| | |
|----------------------|----|
| Flash Program Memory | 99 |
|----------------------|----|

G

| | |
|-----------------|----|
| Getting Started | 37 |
|-----------------|----|

H

| | |
|------------------------------|-----|
| Hi-Speed USB On-The-Go (OTG) | 199 |
|------------------------------|-----|

I

| | |
|--------------------------------|-----|
| I/O Ports | 249 |
| Parallel I/O (PIO) | 250 |
| Write/Read Timing | 250 |
| Input Change Notification | 250 |
| Instruction Set | 605 |
| Inter-Integrated Circuit (I2C) | 355 |
| Internet Address | 717 |

PIC32MZ Embedded Connectivity with Floating Point Unit (EF) Family

| | | | |
|---|-----|--|---------------|
| Interrupt Controller | | ADEVCFG (Alternate Device Configuration Word Summary) | 585 |
| IRG, Vector and Bit Location | 118 | CAN1 Register Summary | 488 |
| M | | CAN2 Register Summary | 490 |
| Memory Maps | | Comparator | 570 |
| Devices with 1024 KB Program Memory and 256 KB RAM | 63 | Comparator Voltage Reference | 574 |
| Devices with 1024 KB Program Memory and 512 KB RAM | 64 | Deadman Timer | 296 |
| Devices with 2048 KB Program Memory | 65 | DEVCFG (Device Configuration Word Summary) | 584 |
| Devices with 512 KB Program Memory | 62 | Device ID, Revision, and Configuration Summary.... | 586 |
| Memory Organization | 61 | Device Serial Number Summary | 586 |
| Layout | 61 | DMA Channel 0-7 | 177 |
| Microchip Internet Web Site | 717 | DMA CRC | 176 |
| MPLAB Assembler, Linker, Librarian | 608 | DMA Global | 176 |
| MPLAB ICD 3 In-Circuit Debugger System | 609 | EBI | 386 |
| MPLAB PM3 Device Programmer | 609 | Ethernet Controller Register Summary | 527 |
| MPLAB REAL ICE In-Circuit Emulator System | 609 | Flash Controller | 100 |
| MPLAB X Integrated Development Environment Software | 607 | I2C1 Through I2C5 | 357 |
| MPLINK Object Linker/MPLIB Object Librarian | 608 | Input Capture 1-9 | 309 |
| O | | Interrupt | 126 |
| Oscillator Configuration | 155 | Oscillator Configuration | 158 |
| Output Compare | 311 | Output Compare 1-9 | 313 |
| P | | Parallel Master Port | 372 |
| Packaging | 665 | Peripheral Pin Select Input | 276 |
| Details | 667 | Peripheral Pin Select Output | 280 |
| Marking | 665 | PORTA | 258 |
| Parallel Master Port (PMP) | 371 | PORTB | 259 |
| PICkit 3 In-Circuit Debugger/Programmer | 609 | PORTC | 260, 261 |
| Pinout I/O Descriptions | | PORTD | 262, 263, 264 |
| ADC | 16 | PORTE | 265, 266 |
| Alternate Ethernet MII | 33 | PORTF | 267, 268 |
| Alternate Ethernet RMII | 33 | PORTG | 270 |
| CAN | 31 | PORTH | 271, 272 |
| Comparators and CVREF | 27 | PORTJ | 273, 274 |
| EBI | 29 | PORTK | 275 |
| Ethernet MII | 32 | Prefetch | 172 |
| Ethernet RMII | 32 | Resets | 110 |
| External Interrupts | 19 | RTCC | 394 |
| I2C | 27 | SPI1 through SPI6 | 318 |
| Input Capture | 18 | System Bus | 76 |
| JTAG, Trace, and Programming/Debugging | 35 | System Bus Target 0 | 76 |
| Oscillator | 18 | System Bus Target 1 | 77 |
| Output Compare | 19 | System Bus Target 10 | 87 |
| PMP | 28 | System Bus Target 11 | 88 |
| Ports | 20 | System Bus Target 12 | 89 |
| Power, Ground, and Voltage Reference | 34 | System Bus Target 13 | 90 |
| SPI | 26 | System Bus Target 2 | 79 |
| SQI | 34 | System Bus Target 3 | 80 |
| Timers | 24 | System Bus Target 4 | 81 |
| UART | 25 | System Bus Target 5 | 82 |
| USB | 31 | System Bus Target 6 | 83 |
| Power-on Reset (POR) | | System Bus Target 7 | 84 |
| and On-Chip Voltage Regulator | 603 | System Bus Target 8 | 85 |
| Power-Saving Features | 577 | System Bus Target 9 | 86 |
| with CPU Running | 577 | Timer1 | 286 |
| Prefetch Module | 171 | Timer1-Timer9 | 291 |
| R | | UART1-6 | 364 |
| Random Number Generator (RNG) | 423 | USB | 201, 207 |
| Real-Time Clock and Calendar (RTCC) | 393 | Watchdog Timer | 304 |
| Register Map | | Registers | |
| | | [<i>pin name</i>]R (Peripheral Pin Select Input) | 283 |
| | | ADCANCON (ADC Analog Warm-up Control Register) . | 482 |
| | | ADCBASE (ADC Base) | 475 |
| | | ADCCMP1CON (ADC Digital Comparator 1 Control Register) | 469 |

PIC32MZ Embedded Connectivity with Floating Point Unit (EF) Family

| | | | |
|--|-----|---|-----|
| ADCCMPENx (ADC Digital Comparator 'x' Enable Register ('x' = 1 through 6))..... | 462 | 31))..... | 520 |
| ADCCMPx (ADC Digital Comparator 'x' Limit Value Register ('x' = 1 through 6))..... | 463 | CiFIFOINTn (CAN FIFO Interrupt Register 'n' ('n' = 0-31))..... | 522 |
| ADCCMPxCON (ADC Digital Comparator 'x' Control Register ('x' = 1 through 6))..... | 471 | CiFIFOUAn (CAN FIFO User Address Register 'n' ('n' = 0-31))..... | 524 |
| ADCCON1 (ADC Control Register 1)..... | 439 | CiFLTCON0 (CAN Filter Control Register 0)..... | 502 |
| ADCCON2 (ADC Control Register 2)..... | 442 | CiFLTCON1 (CAN Filter Control Register 1)..... | 504 |
| ADCCON3 (ADC Control Register 3)..... | 444 | CiFLTCON2 (CAN Filter Control Register 2)..... | 506 |
| ADCCSS1 (ADC Common Scan Select Register 1)..... | 459 | CiFLTCON3 (CAN Filter Control Register 3)..... | 508 |
| ADCCSS2 (ADC Common Scan Select Register 2)..... | 460 | CiFLTCON4 (CAN Filter Control Register 4)..... | 510 |
| ADCDATAx (ADC Output Data Register ('x' = 0 through 44))..... | 476 | CiFLTCON5 (CAN Filter Control Register 5)..... | 512 |
| ADCDSTAT1 (ADC Data Ready Status Register 1)..... | 461 | CiFLTCON6 (CAN Filter Control Register 6)..... | 514 |
| ADCDSTAT2 (ADC Data Ready Status Register 2)..... | 461 | CiFLTCON7 (CAN Filter Control Register 7)..... | 516 |
| ADCEIEN1 (ADC Early Interrupt Enable Register 1)..... | 479 | CiFSTAT (CAN FIFO Status)..... | 499 |
| ADCEIEN2 (ADC Early Interrupt Enable Register 2)..... | 479 | CiRxFn (CAN Acceptance Filter 'n' Register 7 ('n' = 0-31))..... | 518 |
| ADCEIEN2 (ADC Early Interrupt Enable Register 2)..... | 481 | CiRXMn (CAN Acceptance Filter Mask 'n' Register ('n' = 0-3))..... | 501 |
| ADCEIEN2 (ADC Early Interrupt Status Register 2)..... | 481 | CiRXOVF (CAN Receive FIFO Overflow Status)..... | 500 |
| ADCFILTRx (ADC Digital Filter 'x' Register ('x' = 1 through 6))..... | 464 | CiTMR (CAN Timer)..... | 500 |
| ADCGIRQEN1 (ADC Interrupt Enable Register 1)..... | 458 | CiTREC (CAN Transmit/Receive Error Count)..... | 499 |
| ADCIMCON1 (ADC Input Mode Control Register 1)..... | 449 | CiVEC (CAN Interrupt Code)..... | 498 |
| ADCIMCON2 (ADC Input Mode Control Register 2)..... | 452 | CMSTAT (Comparator Control Register)..... | 572 |
| ADCIMCON3 (ADC Input Mode Control Register 3)..... | 455 | CMxCON (Comparator Control)..... | 571 |
| ADCIRQEN2 (ADC Interrupt Enable Register 2)..... | 458 | CNCONx (Change Notice Control for PORTx)..... | 284 |
| ADCSYSCFG1 (ADC System Configuration Register 1)..... | 485 | CONFIG (Configuration Register - CP0 Register 16, Select 0)..... | 51 |
| ADCSYSCFG2 (ADC System Configuration Register 2)..... | 485 | CONFIG1 (Configuration Register 1 - CP0 Register 16, Select 1)..... | 52 |
| ADCTRG1 (ADC Trigger Source 1 Register)..... | 466 | CONFIG3 (Configuration Register 3 - CP0 Register 16, Select 3)..... | 53 |
| ADCTRG2 (ADC Trigger Source 2 Register)..... | 467 | CONFIG5 (Configuration Register 5 - CP0 Register 16, Select 5)..... | 54 |
| ADCTRG3 (ADC Trigger Source 3 Register)..... | 468 | CONFIG7 (Configuration Register 7 - CP0 Register 16, Select 7)..... | 54 |
| ADCTRGMODE (ADC Triggering Mode for Dedicated ADC)..... | 447 | CVRCON (Comparator Voltage Reference Control)..... | 575 |
| ADCTRGSENS (ADC Trigger Level/Edge Sensitivity)..... | 477 | DCHxCON (DMA Channel x Control)..... | 188 |
| ADCxCFG (ADCx Configuration Register 'x' ('x' = 1 through 6))..... | 484 | DCHxCPTR (DMA Channel x Cell Pointer)..... | 196 |
| ADCxTIME (Dedicated ADCx Timing Register 'x' ('x' = 0 through 4))..... | 478 | DCHxCSIZ (DMA Channel x Cell-Size)..... | 196 |
| ALRMTIME (Alarm Time Value)..... | 401 | DCHxDAT (DMA Channel x Pattern Data)..... | 197 |
| BFxSEQ0/ABFxSEQ0 (Boot Flash 'x' Sequence Word 0 Register)..... | 70 | DCHxDPTR (Channel x Destination Pointer)..... | 195 |
| CEBDADDR (Crypto Engine Buffer Descriptor)..... | 407 | DCHxDSA (DMA Channel x Destination Start Address)..... | 193 |
| CEBDPADDR (Crypto Engine Buffer Descriptor Processor)..... | 407 | DCHxDSIZ (DMA Channel x Destination Size)..... | 194 |
| CECON (Crypto Engine Control)..... | 406 | DCHxECON (DMA Channel x Event Control)..... | 190 |
| CEHDLEN (Crypto Engine Header Length)..... | 413 | DCHxINT (DMA Channel x Interrupt Control)..... | 191 |
| CEINTEN (Crypto Engine Interrupt Enable)..... | 411 | DCHxSPTR (DMA Channel x Source Pointer)..... | 195 |
| CEINTSRC (Crypto Engine Interrupt Source)..... | 410 | DCHxSSA (DMA Channel x Source Start Address)..... | 193 |
| CEPOLLCON (Crypto Engine Poll Control)..... | 412 | DCHxSSIZ (DMA Channel x Source Size)..... | 194 |
| CESTAT (Crypto Engine Status)..... | 408 | DCRCCON (DMA CRC Control)..... | 185 |
| CETRLLEN (Crypto Engine Trailer Length)..... | 413 | DCRCDATA (DMA CRC Data)..... | 187 |
| CEVER (Crypto Engine Revision, Version, and ID)..... | 405 | DCRCXOR (DMA CRCXOR Enable)..... | 187 |
| CFGEBIA (External Bus Interface Address Pin Configuration)..... | 598 | DEVCFG0/ADEVCFG0 (Device Configuration Word 0)..... | 588 |
| CFGEBIC (External Bus Interface Control Pin Configuration)..... | 599 | DEVCFG1/ADEVCFG1 (Device Configuration Word 1)..... | 590 |
| CFGPG (Permission Group Configuration)..... | 601 | DEVCFG2/ADEVCFG2 (Device Configuration Word 2)..... | 593 |
| CiCFG (CAN Baud Rate Configuration)..... | 494 | DEVCFG3/ADEVCFG3 (Device Configuration Word 3)..... | 595 |
| CiCON (CAN Module Control)..... | 492 | DEVCP0/ADEVCP0 (Device Code-Protect 0)..... | 587 |
| CiFIFOBA (CAN Message Buffer Base Address)..... | 519 | DEVID (Device and Revision ID)..... | 602 |
| CiFIFOCIn (CAN Module Message Index Register 'n' ('n' = 0-31))..... | 524 | DEVSIGN0/ADEVSIGN0 (Device Signature Word 0)..... | 587 |
| CiFIFOCOn (CAN FIFO Control Register 'n' ('n' = 0-31))..... | 520 | DMAADDR (DMA Address)..... | 184 |

PIC32MZ Embedded Connectivity with Floating Point Unit (EF) Family

| | | | |
|---|-----|--|----------|
| DMACON (DMA Controller Control)..... | 183 | ETHPM0 (Ethernet Controller Pattern Match Offset) | 536 |
| DMASTAT (DMA Status) | 184 | ETHPMCS (Ethernet Controller Pattern Match Checksum)..... | 536 |
| DMSTAT (Deadman Timer Status)..... | 299 | ETHPMM0 (Ethernet Controller Pattern Match Mask 0). 535 | |
| DMTCLR (Deadman Timer Clear) | 298 | ETHPMM1 (Ethernet Controller Pattern Match Mask 1). 535 | |
| DMTCNT (Deadman Timer Count)..... | 300 | ETHRXFC (Ethernet Controller Receive Filter Configuration)..... | 537 |
| DMTCON (Deadman Timer Control)..... | 297 | ETHRXOVFLOW (Ethernet Controller Receive Overflow Statistics) | 545 |
| DMTPRECLR (Deadman Timer Preclear) | 297 | ETHRXST (Ethernet Controller RX Packet Descriptor Start Address)..... | 533 |
| DMTPSINTV (Post Status Configure DMT Interval Status) | 301 | ETHRXWM (Ethernet Controller Receive Watermarks) . 539 | |
| EBICSx (External Bus Interface Chip Select) | 387 | ETHSCOLFRM (Ethernet Controller Single Collision Frames Statistics)..... | 547 |
| EBIFTRPDx (External Bus Interface Flash Timing) .. | 390 | ETHSTAT (Ethernet Controller Status)..... | 543 |
| EBIMSKx (External Bus Interface Address Mask) | 388 | ETHTXST (Ethernet Controller TX Packet Descriptor Start Address)..... | 533 |
| EBISMCON (External Bus Interface Static Memory Control)..... | 391 | FCCR (Floating Point Condition Codes Register - CP1 Register 25)..... | 56 |
| EBISMTx (External Bus Interface Static Memory Timing) 389 | | FCSR (Floating Point Control and Status Register - CP1 Register 31) | 59 |
| EMAC1CFG1 (Ethernet Controller MAC Configuration 1) 552 | | FENR (Floating Point Exceptions and Modes Enable Register - CP1 Register 28) | 58 |
| EMAC1CFG2 (Ethernet Controller MAC Configuration 2) 553 | | FEXR (Floating Point Exceptions Status Register - CP1 Register 26) | 57 |
| EMAC1CLRT (Ethernet Controller MAC Collision Window/Retry Limit) | 557 | FIR (Floating Point Implementation Register - CP1 Register 0)..... | 55 |
| EMAC1IPGR (Ethernet Controller MAC Non-Back-to-Back Interpacket Gap) | 556 | I2CxCON (I2C Control)..... | 359 |
| EMAC1IPGT (Ethernet Controller MAC Back-to-Back Interpacket Gap) | 555 | I2CxSTAT (I2C Status)..... | 361 |
| EMAC1MADR (Ethernet Controller MAC MII Management Address)..... | 563 | ICxCON (Input Capture x Control)..... | 310 |
| EMAC1MAXF (Ethernet Controller MAC Maximum Frame Length) | 558 | IECx (Interrupt Enable Control) | 150 |
| EMAC1MCFG (Ethernet Controller MAC MII Management Configuration) | 561 | IFSx (Interrupt Flag Status) | 150 |
| EMAC1MCMD (Ethernet Controller MAC MII Management Command) | 562 | INTCON (Interrupt Control)..... | 146 |
| EMAC1MIND (Ethernet Controller MAC MII Management Indicators) | 565 | INTSTAT (Interrupt Status)..... | 149 |
| EMAC1MRDD (Ethernet Controller MAC MII Management Read Data)..... | 564 | IPCx (Interrupt Priority Control) | 151 |
| EMAC1MWTD (Ethernet Controller MAC MII Management Write Data)..... | 564 | IPTMR (Interrupt Proximity Timer)..... | 149 |
| EMAC1SA0 (Ethernet Controller MAC Station Address 0)..... | 566 | NVMADDR (Flash Address) | 104 |
| EMAC1SA1 (Ethernet Controller MAC Station Address 1)..... | 567 | NVMBWP (Flash Boot (Page) Write-protect)..... | 107 |
| EMAC1SA2 (Ethernet Controller MAC Station Address 2)..... | 568 | NVMCON (Programming Control) | 101, 103 |
| EMAC1SUPP (Ethernet Controller MAC PHY Support) . 559 | | NVMDATAx (Flash Data ('x' = 0-3)) | 105 |
| EMAC1TEST (Ethernet Controller MAC Test) | 560 | NVMKEY (Programming Unlock)..... | 104 |
| ETHALGNERR (Ethernet Controller Alignment Errors Statistics) | 551 | NVMPWP (Program Flash Write-Protect)..... | 106 |
| ETHCON1 (Ethernet Controller Control 1)..... | 530 | NVMSRCADDR (Source Data Address) | 105 |
| ETHCON2 (Ethernet Controller Control 2)..... | 532 | OCxCON (Output Compare x Control) | 315 |
| ETHFCSERR (Ethernet Controller Frame Check Sequence Error Statistics)..... | 550 | OSCCON (Oscillator Control)..... | 160 |
| ETHFRMRXOK (Ethernet Controller Frames Received OK Statistics) | 549 | OSCTUN (FRC Tuning)..... | 162 |
| ETHFRMTXOK (Ethernet Controller Frames Transmitted OK Statistics) | 546 | PMADDR (Parallel Port Address)..... | 377 |
| ETHHT0 (Ethernet Controller Hash Table 0) | 534 | PMEN (Parallel Port Pin Enable)..... | 379 |
| ETHHT1 (Ethernet Controller Hash Table 1) | 534 | PMCON (Parallel Port Control)..... | 373 |
| ETHIEN (Ethernet Controller Interrupt Enable)..... | 540 | PMDIN (Parallel Port Input Data)..... | 378, 383 |
| ETHIRQ (Ethernet Controller Interrupt Request) | 541 | PMDOUT (Parallel Port Output Data)..... | 378 |
| ETHMCOLFRM (Ethernet Controller Multiple Collision Frames Statistics) | 548 | PMMODE (Parallel Port Mode)..... | 375 |
| | | PMRADDR (Parallel Port Read Address)..... | 382 |
| | | PMSTAT (Parallel Port Status (Slave Modes Only)).. | 380 |
| | | PMWADDR (Parallel Port Write Address) | 381 |
| | | PRECON (Prefetch Module Control) | 173 |
| | | PRESTAT (Prefetch Module Status) | 174 |
| | | PRISS (Priority Shadow Select) | 147 |
| | | PSCNT (Post Status Configure DMT Count Status). 300 | |
| | | PWRCON (Power Control) | 114 |
| | | REFOxCON (Reference Oscillator Control ('x' = 1-4)) ... 165 | |

PIC32MZ Embedded Connectivity with Floating Point Unit (EF) Family

| | |
|---|-----|
| REFOxTRIM (Reference Oscillator Trim ('x' = 1-4)) | 166 |
| RNMICON (Non-maskable Interrupt Control) | 113 |
| RPnR (Peripheral Pin Select Output) | 283 |
| RSWRST (Software Reset) | 112 |
| RTCALRM (RTC ALARM Control) | 397 |
| RTCCON (RTCC Control) | 395 |
| RTCDATE (Real-Time Clock Date Value) | 400 |
| RTCTIME (Real-Time Clock Time Value) | 399 |
| SBFLAG (System Bus Status Flag) | 91 |
| SBTxECLRM (System Bus Target 'x' Multiple Error Clear ('x' = 0-13)) | 95 |
| SBTxECLRS (System Bus Target 'x' Single Error Single ('x' = 0-13)) | 95 |
| SBTxECON (System Bus Target 'x' Error Control ('x' = 0-13)) | 94 |
| SBTxELOG1 (System Bus Target 'x' Error Log 1 ('x' = 0-13)) | 92 |
| SBTxELOG2 (System Bus Target 'x' Error Log 2 ('x' = 0-13)) | 94 |
| SBTxRDy (System Bus Target 'x' Region 'y' Read Permissions ('x' = 0-13)) | 97 |
| SBTxREGy (System Bus Target 'x' Region 'y' ('x' = 0-13)) | 96 |
| SBTxWRy (System Bus Target 'x' Region 'y' Write Permissions ('x' = 0-13)) | 98 |
| SPIxCON (SPI Control) | 320 |
| SPIxCON2 (SPI Control 2) | 323 |
| SPIxSTAT (SPI Status) | 324 |
| SPLLCON (System PLL Control) | 163 |
| SQI1XCON1 (SQI XIP Control 1) | 330 |
| SQI1XCON2 (SQI XIP Control Register 2) | 332 |
| T1CON (Type A Timer Control) | 287 |
| TxCON (Type B Timer Control) | 293 |
| USBCSR0 (USB Control Status 0) | 208 |
| USBCSR1 (USB Control Status 1) | 210 |
| USBCSR2 (USB Control Status 2) | 211 |
| USBCSR3 (USB Control Status 3) | 213 |
| USBCSRCON (USB Clock/Reset Control) | 247 |
| USBDMINT (USB DMA Interrupt) | 238 |
| USBDMAx (USB DMA Channel 'x' Memory Address) | 240 |
| USBDMAxC (USB DMA Channel 'x' Control) | 239 |
| USBDMAxN (USB DMA Channel 'x' Count) | 240 |
| USBDPBF (USB Double Packet Buffer Disable) | 241 |
| USBEOFRST (USB End-of-Frame/Soft Reset Control) | 235 |
| USBExRPC (USB Endpoint 'x' Request Packet Count (Host Mode Only)) | 241 |
| USBExRXA (USB Endpoint 'x' Receive Address) | 237 |
| USBExTXA (USB Endpoint 'x' Transmit Address) | 236 |
| USBFI (USB FIFO Address) | 232 |
| USBHWVER (USB Hardware Version) | 233 |
| USBIE0CSR0 (USB Indexed Endpoint Control Status 0 (Endpoint 0)) | 215 |
| USBIE0CSR2 (USB Indexed Endpoint Control Status 2 (Endpoint 0)) | 217 |
| USBIE0CSR3 (USB Indexed Endpoint Control Status 3 (Endpoint 0)) | 218 |
| USBIECSR0 (USB Indexed Endpoint Control Status 0 (Endpoint 1-7)) | 219 |
| USBIECSR1 (USB Indexed Endpoint Control Status 1 (Endpoint 1-7)) | 222 |
| USBIECSR2 (USB Indexed Endpoint Control Status 2 (Endpoint 1-7)) | 225 |
| USBIECSR3 (USB Indexed Endpoint Control Status 3 (Endpoint 1-7)) | 226 |
| USBINFO (USB Information) | 234 |
| USBLPMR1 (USB Link Power Management Control 1) | 243 |
| USBLPMR2 (USB Link Power Management Control 2) | 245 |
| USBTMCON1 (USB Timing Control 1) | 242 |
| USBTMCON2 (USB Timing Control 2) | 242 |
| WDTCN (Watchdog Timer Control) | 305 |
| Resets | 109 |
| Revision History | 707 |
| S | |
| Serial Peripheral Interface (SPI) and Inter-IC Sound (I2S) | 317 |
| Serial Quad Interface (SQI) | 327 |
| Software Simulator (MPLAB X SIM) | 609 |
| Special Features | 583 |
| T | |
| Timer1 Module | 285 |
| Timer2/3, Timer4/5, Timer6/7, and Timer8/9 Modules | 289 |
| Timing Diagrams | |
| CAN I/O | 649 |
| EJTAG | 662 |
| External Clock | 625 |
| I/O Characteristics | 628 |
| I2Cx Bus Data (Master Mode) | 645 |
| I2Cx Bus Data (Slave Mode) | 647 |
| I2Cx Bus Start/Stop Bits (Master Mode) | 645 |
| I2Cx Bus Start/Stop Bits (Slave Mode) | 647 |
| Input Capture (CAPx) | 634 |
| OCx/PWM | 635 |
| Output Compare (OCx) | 635 |
| Parallel Master Port Read | 655 |
| Parallel Master Port Write | 656 |
| Parallel Slave Port | 654 |
| SPIx Master Mode (CKE = 0) | 636 |
| SPIx Master Mode (CKE = 1) | 638 |
| SPIx Slave Mode (CKE = 0) | 640 |
| SPIx Slave Mode (CKE = 1) | 641 |
| Timer1-Timer9 External Clock | 633 |
| UART Reception | 370 |
| UART Transmission (8-bit or 9-bit Data) | 370 |
| Timing Requirements | |
| CLKO and I/O | 629 |
| Timing Specifications | |
| CAN I/O Requirements | 649 |
| I2Cx Bus Data Requirements (Master Mode) | 645 |
| I2Cx Bus Data Requirements (Slave Mode) | 647 |
| Input Capture Requirements | 634 |
| Output Compare/PWM Requirements | 635 |
| Simple OCx/PWM Mode Requirements | 635 |
| SPIx Master Mode (CKE = 0) Requirements | 637 |
| SPIx Master Mode (CKE = 1) Requirements | 639 |
| SPIx Slave Mode (CKE = 1) Requirements | 641 |
| SPIx Slave Mode Requirements (CKE = 0) | 640 |
| U | |
| UART | 363 |
| USB Interface Diagram | 200 |
| V | |
| Voltage Regulator (On-Chip) | 603 |

PIC32MZ Embedded Connectivity with Floating Point Unit (EF) Family

W

| | |
|---------------------------|-----|
| WWW Address..... | 717 |
| WWW, On-Line Support..... | 12 |

THE MICROCHIP WEB SITE

Microchip provides online support via our WWW site at www.microchip.com. This web site is used as a means to make files and information easily available to customers. Accessible by using your favorite Internet browser, the web site contains the following information:

- **Product Support** – Data sheets and errata, application notes and sample programs, design resources, user's guides and hardware support documents, latest software releases and archived software
- **General Technical Support** – Frequently Asked Questions (FAQ), technical support requests, online discussion groups, Microchip consultant program member listing
- **Business of Microchip** – Product selector and ordering guides, latest Microchip press releases, listing of seminars and events, listings of Microchip sales offices, distributors and factory representatives

CUSTOMER CHANGE NOTIFICATION SERVICE

Microchip's customer notification service helps keep customers current on Microchip products. Subscribers will receive e-mail notification whenever there are changes, updates, revisions or errata related to a specified product family or development tool of interest.

To register, access the Microchip web site at www.microchip.com. Under "Support", click on "Customer Change Notification" and follow the registration instructions.

CUSTOMER SUPPORT

Users of Microchip products can receive assistance through several channels:

- Distributor or Representative
- Local Sales Office
- Field Application Engineer (FAE)
- Technical Support

Customers should contact their distributor, representative or Field Application Engineer (FAE) for support. Local sales offices are also available to help customers. A listing of sales offices and locations is included in the back of this document.

Technical support is available through the web site at: <http://microchip.com/support>

PIC32MZ Embedded Connectivity with Floating Point Unit (EF) Family

PRODUCT IDENTIFICATION SYSTEM

To order or obtain information, e.g., on pricing or delivery, refer to the factory or the listed sales office.

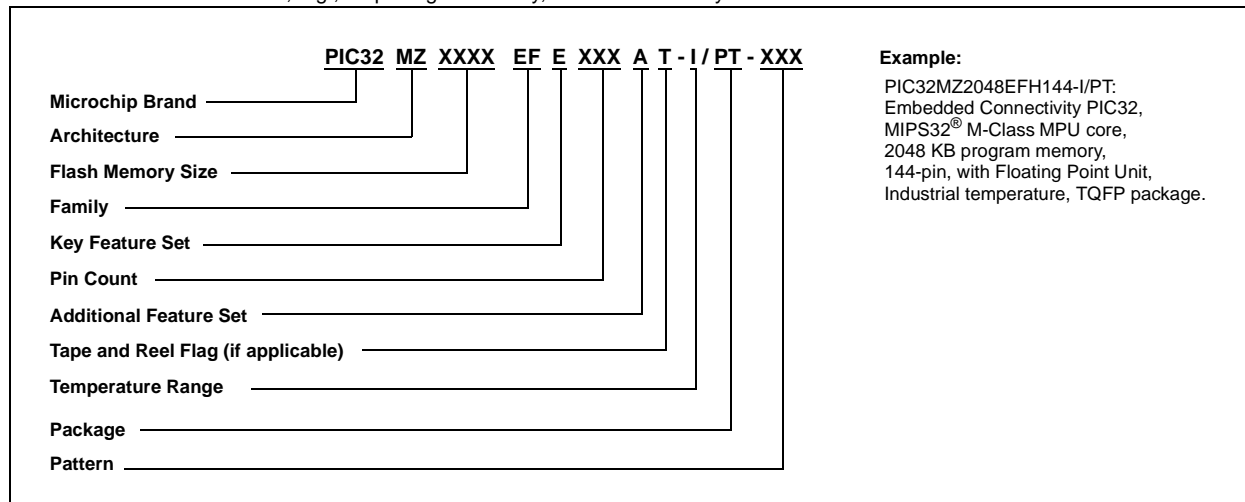

Example:
 PIC32MZ2048EFH144-I/PT:
 Embedded Connectivity PIC32,
 MIPS32[®] M-Class MPU core,
 2048 KB program memory,
 144-pin, with Floating Point Unit,
 Industrial temperature, TQFP package.

Flash Memory Family

| | |
|-------------------|--|
| Architecture | MZ = MIPS32 [®] M-Class MPU Core |
| Flash Memory Size | 0512 = 512 KB 1024 = 1024 KB 2048 = 2048 KB |
| Family | EF = Embedded Connectivity Microcontroller Family with Floating Point Unit |
| Key Feature | E = PIC32 EF Family Features (no CAN, no Crypto) F = PIC32 EF Family Features (CAN, no Crypto) G = PIC32 EF Family Features (no CAN, no Crypto) H = PIC32 EF Family Features (CAN, no Crypto) K = PIC32 EF Family Features (Crypto and CAN) M = PIC32 EF Family Features (Crypto and CAN) |
| Pin Count | 064 = 64-pin 100 = 100-pin 124 = 124-pin 144 = 144-pin |
| Temperature Range | I = -40°C to +85°C (Industrial) E = -40°C to +125°C (Extended) |
| Package | MR = 64-Lead (9x9x0.9 mm) QFN (Plastic Quad Flatpack) PT = 64-Lead (10x10x1 mm) TQFP (Thin Quad Flatpack) PT = 100-Lead (12x12x1 mm) TQFP (Thin Quad Flatpack) PF = 100-Lead (14x14x1 mm) TQFP (Thin Quad Flatpack) TL = 124-Lead (9x9x0.9 mm) VTLA (Very Thin Leadless Array) PH = 144-Lead (16x16x1 mm) TQFP (Thin Quad Flatpack) PL = 144-Lead (20x20x1.40 mm) LQFP (Low Profile Quad Flatpack) |
| Pattern | Three-digit QTP, SQTP, Code or Special Requirements (blank otherwise) ES = Engineering Sample |

Note the following details of the code protection feature on Microchip devices:

- Microchip products meet the specification contained in their particular Microchip Data Sheet.
- Microchip believes that its family of products is one of the most secure families of its kind on the market today, when used in the intended manner and under normal conditions.
- There are dishonest and possibly illegal methods used to breach the code protection feature. All of these methods, to our knowledge, require using the Microchip products in a manner outside the operating specifications contained in Microchip's Data Sheets. Most likely, the person doing so is engaged in theft of intellectual property.
- Microchip is willing to work with the customer who is concerned about the integrity of their code.
- Neither Microchip nor any other semiconductor manufacturer can guarantee the security of their code. Code protection does not mean that we are guaranteeing the product as “unbreakable.”

Code protection is constantly evolving. We at Microchip are committed to continuously improving the code protection features of our products. Attempts to break Microchip's code protection feature may be a violation of the Digital Millennium Copyright Act. If such acts allow unauthorized access to your software or other copyrighted work, you may have a right to sue for relief under that Act.

Information contained in this publication regarding device applications and the like is provided only for your convenience and may be superseded by updates. It is your responsibility to ensure that your application meets with your specifications. MICROCHIP MAKES NO REPRESENTATIONS OR WARRANTIES OF ANY KIND WHETHER EXPRESS OR IMPLIED, WRITTEN OR ORAL, STATUTORY OR OTHERWISE, RELATED TO THE INFORMATION, INCLUDING BUT NOT LIMITED TO ITS CONDITION, QUALITY, PERFORMANCE, MERCHANTABILITY OR FITNESS FOR PURPOSE. Microchip disclaims all liability arising from this information and its use. Use of Microchip devices in life support and/or safety applications is entirely at the buyer's risk, and the buyer agrees to defend, indemnify and hold harmless Microchip from any and all damages, claims, suits, or expenses resulting from such use. No licenses are conveyed, implicitly or otherwise, under any Microchip intellectual property rights.

Trademarks

The Microchip name and logo, the Microchip logo, dsPIC, FlashFlex, flexPWR, JukeBlox, KEELOQ, KEELOQ logo, Klear, LANCheck, MediaLB, MOST, MOST logo, MPLAB, OptoLyzer, PIC, PICSTART, PIC³² logo, RightTouch, SpyNIC, SST, SST Logo, SuperFlash and UNI/O are registered trademarks of Microchip Technology Incorporated in the U.S.A. and other countries.

The Embedded Control Solutions Company and mTouch are registered trademarks of Microchip Technology Incorporated in the U.S.A.

Analog-for-the-Digital Age, BodyCom, chipKIT, chipKIT logo, CodeGuard, dsPICDEM, dsPICDEM.net, ECAN, In-Circuit Serial Programming, ICSP, Inter-Chip Connectivity, KlearNet, KlearNet logo, MiWi, MPASM, MPF, MPLAB Certified logo, MPLIB, MPLINK, MultiTRAK, NetDetach, Omniscient Code Generation, PICDEM, PICDEM.net, PICkit, PICtail, RightTouch logo, REAL ICE, SQI, Serial Quad I/O, Total Endurance, TSHARC, USBCheck, VariSense, ViewSpan, WiperLock, Wireless DNA, and ZENA are trademarks of Microchip Technology Incorporated in the U.S.A. and other countries.

SQTP is a service mark of Microchip Technology Incorporated in the U.S.A.

Silicon Storage Technology is a registered trademark of Microchip Technology Inc. in other countries.

GestIC is a registered trademarks of Microchip Technology Germany II GmbH & Co. KG, a subsidiary of Microchip Technology Inc., in other countries.

All other trademarks mentioned herein are property of their respective companies.

© 2015, Microchip Technology Incorporated, Printed in the U.S.A., All Rights Reserved.

ISBN: 978-1-63277-634-1

QUALITY MANAGEMENT SYSTEM
CERTIFIED BY DNV
== ISO/TS 16949 ==

Microchip received ISO/TS-16949:2009 certification for its worldwide headquarters, design and wafer fabrication facilities in Chandler and Tempe, Arizona; Gresham, Oregon and design centers in California and India. The Company's quality system processes and procedures are for its PIC® MCUs and dsPIC® DSCs, KEELOQ® code hopping devices, Serial EEPROMs, microperipherals, nonvolatile memory and analog products. In addition, Microchip's quality system for the design and manufacture of development systems is ISO 9001:2000 certified.



MICROCHIP

Worldwide Sales and Service

AMERICAS

Corporate Office
2355 West Chandler Blvd.
Chandler, AZ 85224-6199
Tel: 480-792-7200
Fax: 480-792-7277
Technical Support:
<http://www.microchip.com/support>
Web Address:
www.microchip.com

Atlanta
Duluth, GA
Tel: 678-957-9614
Fax: 678-957-1455

Austin, TX
Tel: 512-257-3370

Boston
Westborough, MA
Tel: 774-760-0087
Fax: 774-760-0088

Chicago
Itasca, IL
Tel: 630-285-0071
Fax: 630-285-0075

Cleveland
Independence, OH
Tel: 216-447-0464
Fax: 216-447-0643

Dallas
Addison, TX
Tel: 972-818-7423
Fax: 972-818-2924

Detroit
Novi, MI
Tel: 248-848-4000

Houston, TX
Tel: 281-894-5983

Indianapolis
Noblesville, IN
Tel: 317-773-8323
Fax: 317-773-5453

Los Angeles
Mission Viejo, CA
Tel: 949-462-9523
Fax: 949-462-9608

New York, NY
Tel: 631-435-6000

San Jose, CA
Tel: 408-735-9110

Canada - Toronto
Tel: 905-673-0699
Fax: 905-673-6509

ASIA/PACIFIC

Asia Pacific Office
Suites 3707-14, 37th Floor
Tower 6, The Gateway
Harbour City, Kowloon

Hong Kong
Tel: 852-2943-5100
Fax: 852-2401-3431

Australia - Sydney
Tel: 61-2-9868-6733
Fax: 61-2-9868-6755

China - Beijing
Tel: 86-10-8569-7000
Fax: 86-10-8528-2104

China - Chengdu
Tel: 86-28-8665-5511
Fax: 86-28-8665-7889

China - Chongqing
Tel: 86-23-8980-9588
Fax: 86-23-8980-9500

China - Dongguan
Tel: 86-769-8702-9880

China - Hangzhou
Tel: 86-571-8792-8115
Fax: 86-571-8792-8116

China - Hong Kong SAR
Tel: 852-2943-5100
Fax: 852-2401-3431

China - Nanjing
Tel: 86-25-8473-2460
Fax: 86-25-8473-2470

China - Qingdao
Tel: 86-532-8502-7355
Fax: 86-532-8502-7205

China - Shanghai
Tel: 86-21-5407-5533
Fax: 86-21-5407-5066

China - Shenyang
Tel: 86-24-2334-2829
Fax: 86-24-2334-2393

China - Shenzhen
Tel: 86-755-8864-2200
Fax: 86-755-8203-1760

China - Wuhan
Tel: 86-27-5980-5300
Fax: 86-27-5980-5118

China - Xian
Tel: 86-29-8833-7252
Fax: 86-29-8833-7256

ASIA/PACIFIC

China - Xiamen
Tel: 86-592-2388138
Fax: 86-592-2388130

China - Zhuhai
Tel: 86-756-3210040
Fax: 86-756-3210049

India - Bangalore
Tel: 91-80-3090-4444
Fax: 91-80-3090-4123

India - New Delhi
Tel: 91-11-4160-8631
Fax: 91-11-4160-8632

India - Pune
Tel: 91-20-3019-1500

Japan - Osaka
Tel: 81-6-6152-7160
Fax: 81-6-6152-9310

Japan - Tokyo
Tel: 81-3-6880-3770
Fax: 81-3-6880-3771

Korea - Daegu
Tel: 82-53-744-4301
Fax: 82-53-744-4302

Korea - Seoul
Tel: 82-2-554-7200
Fax: 82-2-558-5932 or
82-2-558-5934

Malaysia - Kuala Lumpur
Tel: 60-3-6201-9857
Fax: 60-3-6201-9859

Malaysia - Penang
Tel: 60-4-227-8870
Fax: 60-4-227-4068

Philippines - Manila
Tel: 63-2-634-9065
Fax: 63-2-634-9069

Singapore
Tel: 65-6334-8870
Fax: 65-6334-8850

Taiwan - Hsin Chu
Tel: 886-3-5778-366
Fax: 886-3-5770-955

Taiwan - Kaohsiung
Tel: 886-7-213-7828

Taiwan - Taipei
Tel: 886-2-2508-8600
Fax: 886-2-2508-0102

Thailand - Bangkok
Tel: 66-2-694-1351
Fax: 66-2-694-1350

EUROPE

Austria - Wels
Tel: 43-7242-2244-39
Fax: 43-7242-2244-393

Denmark - Copenhagen
Tel: 45-4450-2828
Fax: 45-4485-2829

France - Paris
Tel: 33-1-69-53-63-20
Fax: 33-1-69-30-90-79

Germany - Dusseldorf
Tel: 49-2129-3766400

Germany - Karlsruhe
Tel: 49-721-625370

Germany - Munich
Tel: 49-89-627-144-0
Fax: 49-89-627-144-44

Italy - Milan
Tel: 39-0331-742611
Fax: 39-0331-466781

Italy - Venice
Tel: 39-049-7625286

Netherlands - Drunen
Tel: 31-416-690399
Fax: 31-416-690340

Poland - Warsaw
Tel: 48-22-3325737

Spain - Madrid
Tel: 34-91-708-08-90
Fax: 34-91-708-08-91

Sweden - Stockholm
Tel: 46-8-5090-4654

UK - Wokingham
Tel: 44-118-921-5800
Fax: 44-118-921-5820

07/14/15