

APPROVAL SHEET

WF10P

±1%, ±5%

General purpose chip resistors (power)

Size 1210

*Contents in this sheet are subject to change without prior notice.

FEATURE

1. High reliability and stability
2. Reduced size of final equipment
3. Lower assembly costs
4. Higher component and equipment reliability
5. RoHS compliant and Lead free products

APPLICATION

- Consumer electrical equipment
- Automotive application
- EDP, Computer application
- Telecom application

DESCRIPTION

The resistors are constructed in a high grade ceramic body (aluminum oxide). Internal metal electrodes are added at each end and connected by a resistive paste that is applied to the top surface of the substrate. The composition of the paste is adjusted to give the approximate resistance required and the value is trimmed to nominated value within tolerance which controlled by laser trimming of this resistive layer.

The resistive layer is covered with a protective coat. Finally, the two external end terminations are added. For ease of soldering the outer layer of these end terminations is a Tin (lead free) alloy.

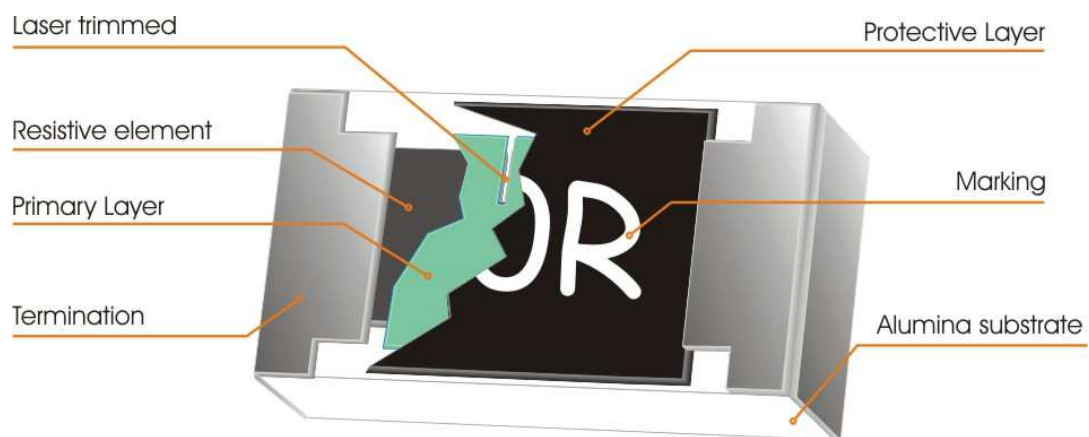

Fig 1. Construction of Chip-R

QUICK REFERENCE DATA

Item	General Specification
Series No.	WF10P
Size code	1210 (3226)
Resistance Tolerance	±1% (E-96), ±5% (E-24)
Resistance Range	Jumper, 1Ω ~ 10MΩ (E96+E24 series)
TCR (ppm/°C) -55°C ~ +155°C	10R ~ 1M0, ≤ ± 100 ppm/°C < 10R; > 1M0, ≤ ± 200 ppm/°C
Max. dissipation at T _{amb} =70°C	1/2 W
Max. Operation Voltage (DC or RMS)	200V (I = 3.2 Amp. For Jumper)
Max. overload voltage	400V (I = 8 Amp. For Jumper)
Climatic category (IEC 60068)	55/155/56
Basic specification	JIS C 5201-1 : 1998

Note :

1. This is the maximum voltage that may be continuously supplied to the resistor element, see "IEC publication 60115-8"
2. Max. Operation Voltage : So called RCWV (Rated Continuous Working Voltage) is determined by

$$RCWV = \sqrt{\text{Rated Power} \times \text{Resistance Value}} \text{ or Max. RCWV listed above, whichever is lower.}$$

DIMENSIONS(unit : mm)

Part No	WF10P
L	3.10 ± 0.10
W	2.60 ± 0.10
Tt	0.50 ± 0.20
Tb	0.50 ± 0.20 *1
t	0.55 ± 0.10

*1: original 0.45+/-0.20

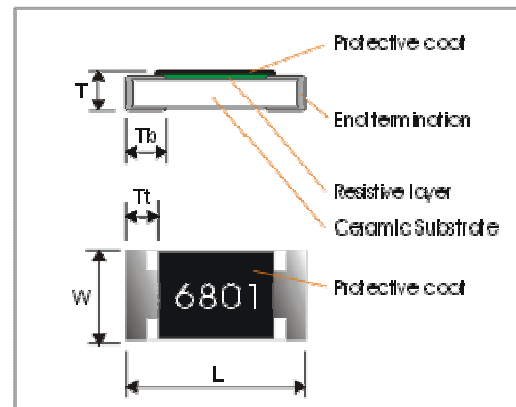

MARKING

4-digits marking for 1%, 3-digits marking for 5%

Example

RESISTANCE	90Ω	100Ω	6800Ω	47000Ω
4-digits marking	90R0	1000	6801	4702
3-digits marking	-	101	682	473

FUNCTIONAL DESCRIPTION

Product characterization

Standard values of nominal resistance are taken from the E96 & E24 series for resistors with a tolerance of $\pm 1\%$, $\pm 5\%$. The values of the E24/E96 series are in accordance with "IEC publication 60063".

Derating

The power that the resistor can dissipate depends on the operating temperature; see Fig.2

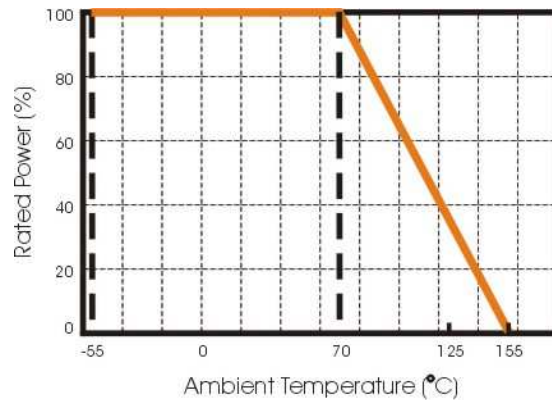

Fig 2. Maximum dissipation in percentage of rated power

As a function of the ambient temperature

MOUNTING

Due to their rectangular shapes and small tolerances, Surface Mountable Resistors are suitable for handling by automatic placement systems.

Chip placement can be on ceramic substrates and printed-circuit boards (PCBs).

Electrical connection to the circuit is by individual soldering condition.

The end terminations guarantee a reliable contact.

SOLDERING CONDITION

The robust construction of chip resistors allows them to be completely immersed in a solder bath of 260°C for 10 seconds. Therefore, it is possible to mount Surface Mount Resistors on one side of a PCB and other discrete components on the reverse (mixed PCBs).

Surface Mount Resistors are tested for solderability at 235°C during 2 seconds. The test condition for no leaching is 260°C for 30 seconds. Typical examples of soldering processes that provide reliable joints without any damage are given in Fig 3.

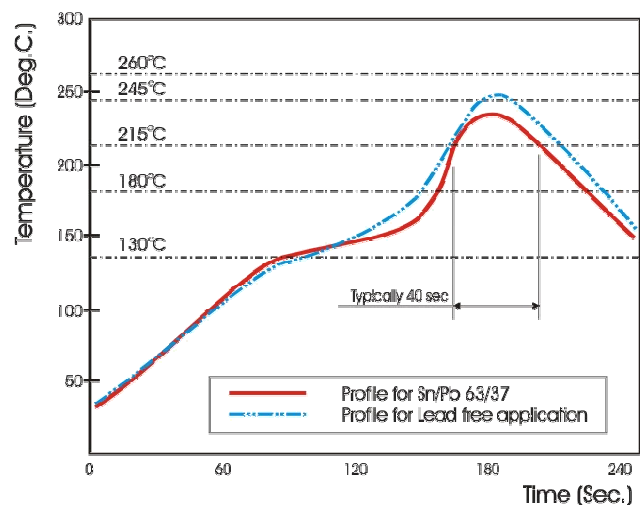

Fig 3. Infrared soldering profile for Chip Resistors

CATALOGUE NUMBERS

The resistors have a catalogue number starting with .

WF10	P	4702	J	T	L
Size code WF10: 1210	Type code P : Power 1210 size=0.5 watt	Resistance code 5%, E24: 2 significant digits followed by no. of zeros 100Ω = 101_ 10KΩ = 103 1%, E24+E96: 3 significant digits followed by no. of zeros 100Ω =1000 37.4KΩ =3742	Tolerance J: ± 5% F: ± 1% P: JUMPER	Packaging code T: 7" Reeled taping	Termination code L = Sn base (lead free)

- Reeled tape packaging : 8mm width paper taping 5000pcs per 7" reel.
- Jumper : WF10P000 PTL

TEST AND REQUIREMENTS(JIS C 5201-1 : 1998)

Basic specification :

The tests are carried out in accordance with IEC publication 68, "Recommended basic climatic and mechanical robustness testing procedure for electronic components" and under standard atmospheric conditions according to IEC 68-1, subclause 5.3, unless otherwise specified.

Temperature: 15°C to 35°C.

Relative humidity: 45% to 75%.

Air pressure: 86kPa to 106 kPa (860 mbar to 1060 mbar).

TEST	PROCEDURE / TEST METHOD	REQUIREMENT	
		Resistor	0Ω
DC resistance Clause 4.5	DC resistance values measured at the test voltages specified below : <10Ω@0.1V, <100Ω@0.3V, <1KΩ@1.0V, <10KΩ@3V, <100KΩ@10V, <1MΩ@25V, <10MΩ@30V	Within the specified tolerance	<50mΩ
Temperature Coefficient of Resistance(T.C.R) Clause 4.8	Natural resistance change per change in degree centigrade. $\frac{R_2 - R_1}{R_1(t_2 - t_1)} \times 10^6 \text{ (ppm/°C)}$ $t_1 : 20^\circ\text{C} \pm 5^\circ\text{C} - 1^\circ\text{C}$ R ₁ : Resistance at reference temperature R ₂ : Resistance at test temperature	Refer to "QUICK REFERENCE DATA"	N/a
Short time overload (S.T.O.L) Clause 4.13	Permanent resistance change after a 5second application of a voltage 2.5 times RCWV or the maximum overload voltage specified in the above list, whichever is less.	ΔR/R max. ±(2%+0.10Ω)	<50mΩ
Resistance to soldering heat(R.S.H) Clause 4.18	Un-mounted chips completely immersed for 10±1second in a SAC solder bath at 260°C ±5°C	ΔR/R max. ±(1%+0.05Ω) no visible damage	<50mΩ
Solderability Clause 4.17	Un-mounted chips completely immersed for 2±0.5 second in a SAC solder bath at 235°C ±5°C	95% coverage min., good tinning and no visible damage	

TEST	PROCEDURE / TEST METHOD	REQUIREMENT	
		Resistor	0Ω
Temperature cycling Clause 4.19	30 minutes at -55°C±3°C, 2~3 minutes at 20°C+5°C-1°C, 30 minutes at +155°C±3°C, 2~3 minutes at 20°C+5°C-1°C, total 5 continuous cycles	$\Delta R/R$ max. $\pm(1\%+0.05\Omega)$	< 50mΩ
Damp Heat (Load life in humidity) Clause 4.24	1000 +48/-0 hours, loaded with RCWV or Vmax in humidity chamber controller at 40°C±2°C and 90~95% relative humidity, 1.5hours on and 0.5 hours off	10Ω≤R<1MΩ : $\Delta R/R$ max. $\pm(3\%+0.10\Omega)$ R<10Ω, R≥1MΩ : $\Delta R/R$ max. $\pm(5\%+0.10\Omega)$	< 50mΩ
Load Life (Endurance) Clause 4.25	1000+48/-0 hours; loaded with RCWV or Vmax in chamber controller 70±2°C, 1.5 hours on and 0.5 hours off	Ditto.	
Bending strength Clause 4.33	Resistors mounted on a 90mm glass epoxy resin PCB(FR4), bending once 3mm for 10sec.	No visual damaged, $\Delta R/R$ max. $\pm(1\%+0.05\Omega)$	< 50mΩ
Adhesion Clause 4.32	Pressurizing force: 5N, Test time: 10±1sec.	No remarkable damage or removal of the terminations	
Insulation Resistance Clause 4.6	Apply the maximum overload voltage (DC) for 1minutes	R ≥ 10GΩ	
Dielectric Withstand Voltage Clause 4.7	Apply the maximum overload voltage (AC) for 1 minutes	No breakdown or flashover	

PACKAGING

Paper Tape specifications (unit :mm)

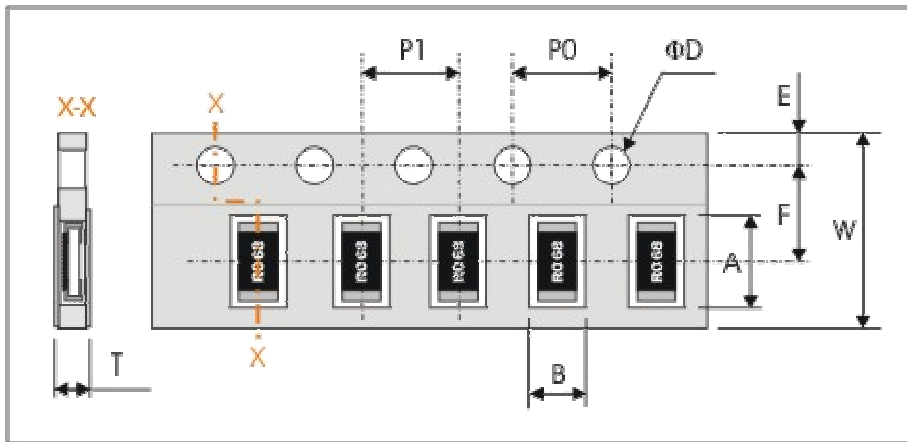

Component Size / Series	W	F	E	P0	ΦD
WF10P	8.00±0.30	3.50±0.20	1.75±0.10	4.00±0.10	Φ1.50 ^{+0.1} _{-0.0}
Component Size / Series	A	B	P1	T	
WF10P	3.60±0.20	3.00±0.20	4.00±0.10	Max. 1.0	

Reel dimensions

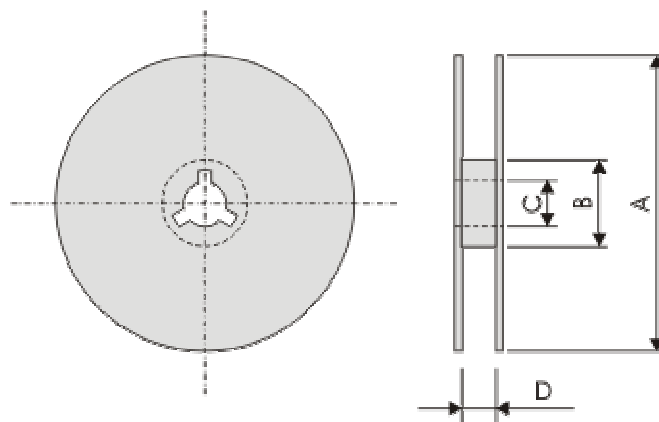

Symbol	A	B	C	D
(unit : mm)	Φ178.0±2.0	Φ60.0±1.0	13.0±0.2	9.0±0.5

Taping quantity

- Chip resistors 5,000 pcs/reel