

Fixed power wirewound resistors
aluminium housed 10 W to 250 W

FIXED POWER WIREWOUND RESISTORS ALUMINIUM HOUSED

FEATURES

Extruded aluminium housing provides superior heat conduction. Housing deep finned for maximum heat dissipation at natural or forced air convection.

Gold anodized finish for maximum resistance to environmental conditions. Special thermosetting compound with high thermal conductivity. Winding designed to give maximum core coverage and uniformity for even heat dissipation.

Core centerless ground for maximum winding uniformity. Marking at top surface for easy identification after mounting. Complete welded construction terminal to terminal.

RB Series



These resistors meet or exceed the requirements of MIL-PRF-18546 G specifications.

ELECTRICAL SPECIFICATIONS

- Ohmic values
Serie E24. For out of range or not standard ohmic values, consult ATE Technical Dept.
- Tolerance
Standard 5%. Available on request up to 1%.
- Temperature coefficient
±30 ppm R > 20 Ohm
±50 ppm 1 Ohm < R < 20 Ohm
±100 ppm 0.1 Ohm < R < 1 Ohm
- Dielectric strength
1500 Vac for RB10
2500 Vac for RB25 and RB50
3500 Vac for RB75, RB101 and RB150
4500 Vac for RB100 and RB250
- Insulation resistance
10000 MOhm minimum
1000 MOhm after moisture test
- Overload
5s at 5 times rated power
- Non inductive

Models of equivalent physical and electrical specifications are also available with non inductive Ayrton-Perry winding

MECHANICAL SPECIFICATIONS

- Terminal strength
10 lb. pull test; 3 Nm x RB100 and 4 Nm x RB250 max torque
- Solderability
Satisfactory when tested in accordance with method 208 of MIL-STD-202. The use of high temperature solder is recommended when resistors work near the maximum specified ratings

MATERIALS

- Core
Ceramic steatite or alumina centerless ground
- Resistive Element
Copper-nickel alloy or nickel-chrome alloy with specific temperature coefficient
- End caps
Stainless steel
- Encapsulant
High temperature thermosetting compound
- Housing
Aluminium with hard anodic finish
- Standard terminals
Copperweld RB10 to RB150
Stainless steel for RB100 and RB250

DERATING

ATE RB resistors have an operative temperature range from -55°C to +250°C. Derating is required for reduced chassis area and for high ambient temperature

Specifications

ATE Type	MIL-PRF-18546 G Type	Rated power (W)	Max power no heatsink (W)	Resistance range (Ohm)	Voltage limit (V)	Temp. rise with heatsink (W)	Weight (g)	Heatsink dimensions (cm ² x mm)
RB10	RE65	12	6	0.01-10K	265	5.1	6	415x1
RB25	RE70	25	12.5	0.01-18K	550	3	14	535x1
RB50	RE75	50	20	0.01-68K	1250	1.9	35	930x1.5
RB75	-	75	35	0.1-50K	1400	1.1	85	995x3
RB101	-	100	40	0.1-70K	1900	1	115	995x3
RB150	-	150	55	0.1-100K	2500	1	165	995x3
RB100	RE77	150	75	0.1-100K	1900	0.84	500	930x3
RB250	RE80	250	100	0.1-120K	2300	0.66	900	930x3

Fixed power wirewound resistors
aluminium housed 10 W to 250 W

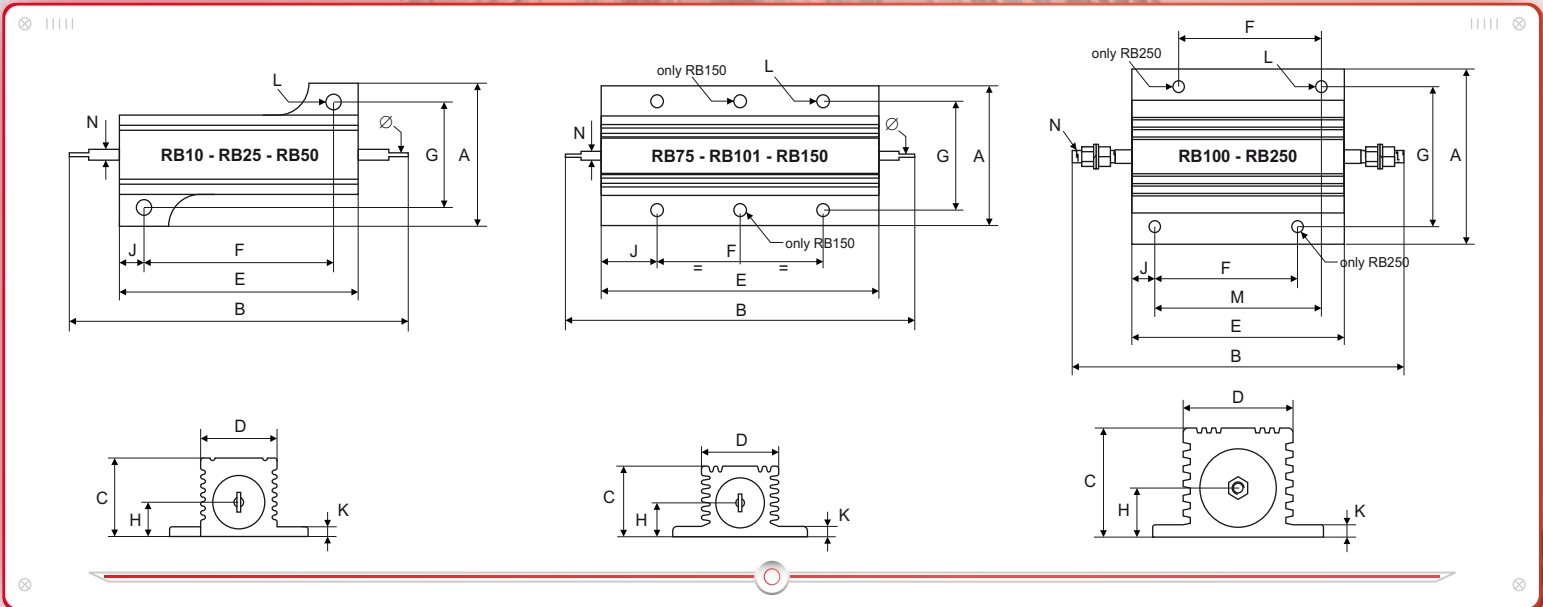
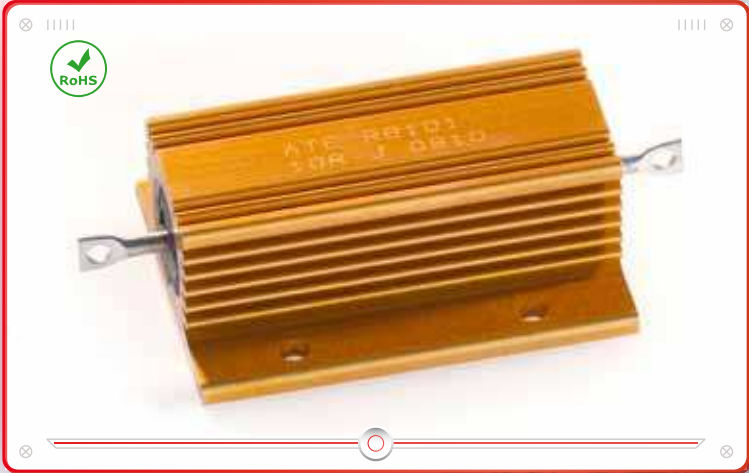

ATE Type	Dimensions (mm)													
	A	B	C	D	E	F	G	H	J	K	L	M	N	Ø
RB10	20.4	35	10	11	19	14.3	15.9	5	2.4	2	2.4	-	2	2.2
RB25	27.2	49	14	14	27	18.3	19.8	6.5	4.4	2	3.2	-	2	2.2
RB50	29.2	71	16	16	50	39.7	21.5	7	5.2	2	3.2	-	2	2.2
RB75	47	73	24	27	48	29	37	11.5	9.5	3.5	4.4	-	3	3.2
RB101	47	89	24	27	64	35	37	11.5	14.5	3.5	4.4	-	3	3.2
RB150	47	122	24	27	97	58	37	11.5	19.5	3.5	4.4	-	3	3.2
RB100	71.5	139	44.5	46	89	-	57.1	20	9.6	5	4.8	69.8	M5	-
RB250	76	178	55.6	54	114	76.2	63.5	25.5	7.8	6.3	4.8	98.4	M6	-
Tol.	±0.2	±1	±0.2	±0.2	±0.5	±0.2	±0.2	±0.2	±0.5	±0.2	±0.2	±0.2	±0.2	±0.2