

# Subracks - *europac* PRO

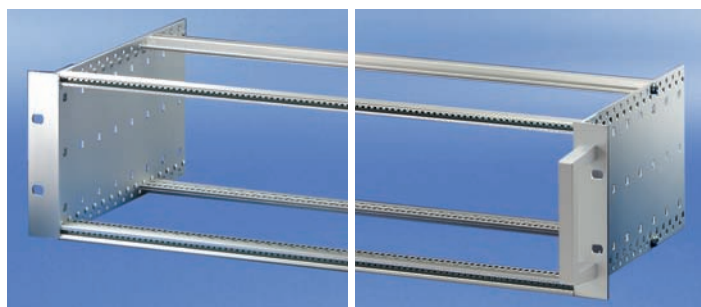

Without front handle

06102007

With front handle

06111003

Kit, 'heavy', unshielded, for backplane mounting

- Subrack with side panel type H ("heavy"), 19" bracket is firmly fixed to side panel (tox-cold welded)
- Rear horizontal rail for backplane mounting with insulation strip
- Shock and vibration resistance up to 5 g
- Installed load up to 15 kg
- Versions with/without front handles

**NEW**

## Delivery comprises (Kit)

Item	Qty	Description
3 U 6 U		
1	2 2	Side panel type H, Al, 2 mm, passivated, with 19" support bracket (tox-cold welded) for textile EMC gasket
2a	2 2	Front horizontal rail (H-KD)
2b	2 2	Rear horizontal rail (H-ST)
2c	- 1	Rear horizontal rail centre (H-ST)
3	4 6	Threaded insert, front and rear (pre-fitted)
4	2 4	Insulation strip (pre-fitted)
5	1 1	Fixing material kit, user manual
6	2 2	Front handle (on version with front handle only)

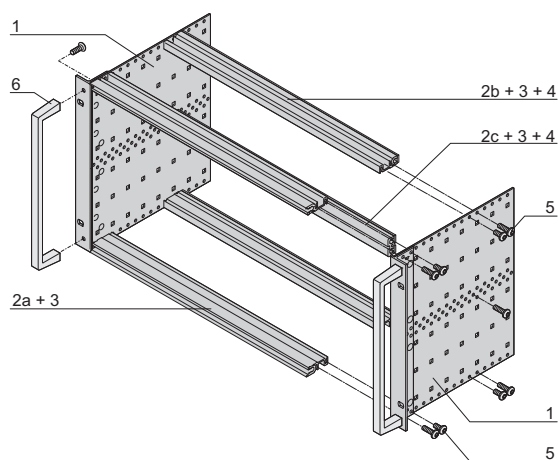

6 U

06111057

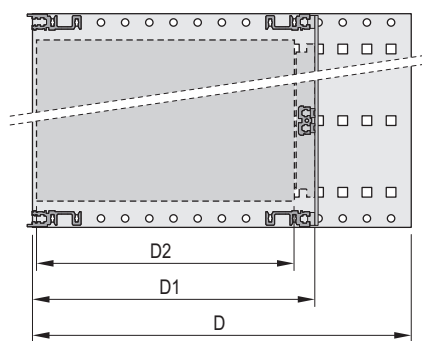

06108052

D = overall depth, D1 = insertion depth, D2 = board depth



04400001

Rear horizontal rail for backplane mounting with insulation strip

## Order Information

Height U	Width HP	Depth D mm	Depth D1 mm	Part no. with front handle	Part no. without front handle
3	84	175	175	24567-161	24563-161
3	84	235	175/235	24567-162	24563-162
3	84	295	175/235/295	24567-163	24563-163
3	84	355	175/235/295/355	24567-164	24563-164
6	84	175	175	24567-461	24563-461
6	84	235	175/235	24567-462	24563-462
6	84	295	175/235/295	24567-463	24563-463
6	84	355	175/235/295/355	24567-464	24563-464

## Accessories

**19" assembly kit (screw, washer, nut) (**  
8 x screws, 8 x plastic washers, 8 x cage nuts)  
21100-435

## Guide rails (standard), ESD clips

Depth D2 mm	Qty/PU piece	Part no.
160	10	24560-351
220	10	24560-353
280	10	24560-379
340	10	24560-380

**ESD clip for guide rails** PU 50 pieces 24560-255

**Torx panhead screw**, for extra bolting of the guide rails, 2.5 x 9.3, zinc-plated, PU 100 pieces; torque max. 0.2 Nm 24560-141

## Cover plates for bolting to side panel

Depth D2 mm	Width HP	Qty/PU piece	Part no.
160	84	2	24560-078
220	84	2	24560-079
280	84	2	24560-080
340	84	2	24560-081

## Note

- ServicePLUS configuration from page 6.16



ServicePLUS see page 6.16