

# M.478 | Bridge handle

Technopolymer



- 1
- 2
- 3
- 4
- 5
- 6
- 7
- 8
- 9
- 10
- 11
- 12
- 13
- 14
- 15
- 16
- 17
- 18

## MATERIAL

Glass-fibre reinforced polyamide based (PA) technopolymer, black colour, glossy finish.

## STANDARD EXECUTION

Pass-through holes for screws or rivets.

## TECHNICAL DATA

Tensile stress and impact strength: the values F1, F2, L1 and L2 indicated in the table were obtained during breaking tests carried out with the appropriate dynamometric equipment under the test conditions shown in the figure with ambient temperature.

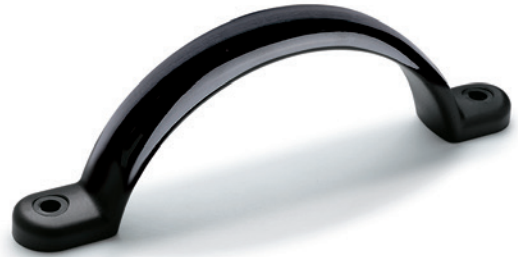

ELESA Original design

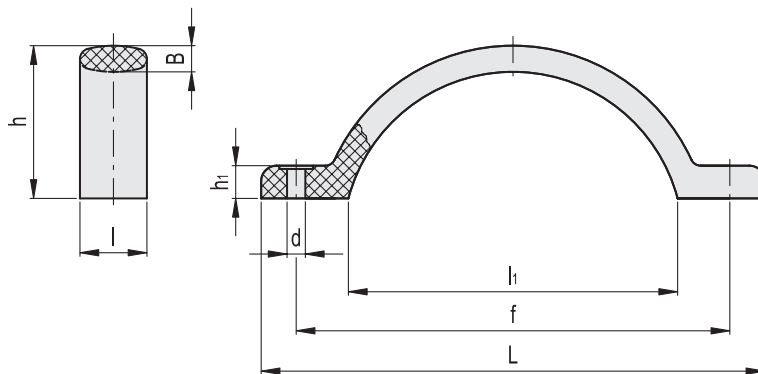
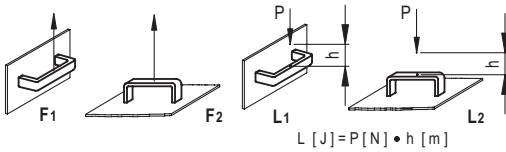

Lift & Pull handles

Code	Description	L	f	d	h	h1	B	l	l1	F1 [N]	F2 [N]	L1 [J]	L2 [J]	
37451	M.478/150-6	173	150±0.5	6	52.5	9	8	23	113	1800	4500	18	8	46