

## Features

- Two accuracy ranks,  $\pm 1.5\%$ FS and  $\pm 2.5\%$ FS available
- Volt level output
- On-chip amplification and temperature compensations
- Pre-calibration of offset voltage and span
- Non-corrosive liquid measurable (XFGMC only)

## Applications

- Industrial instrumentation
- Pressure switch, Pneumatic device
- Medical device

## Part number for ordering

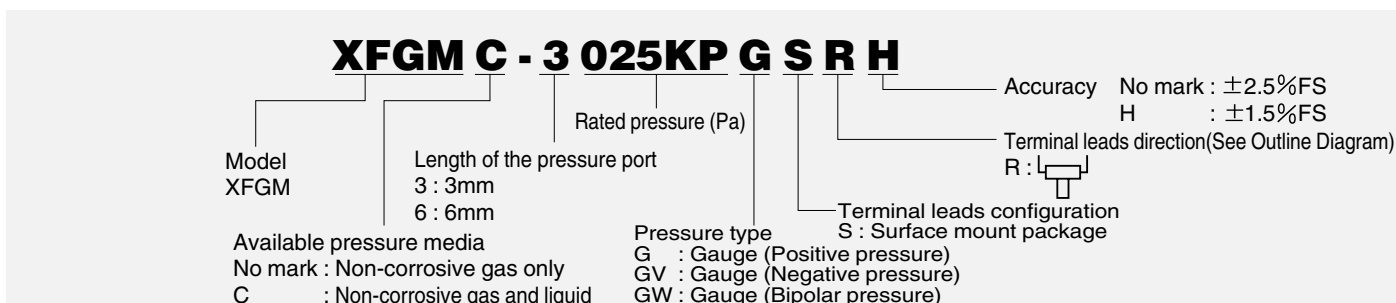

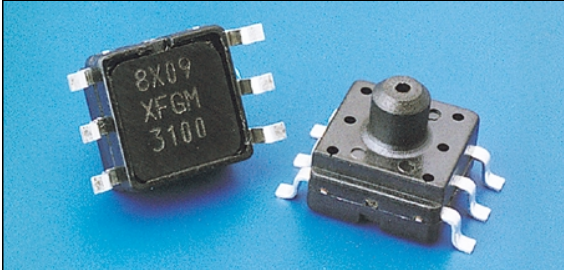
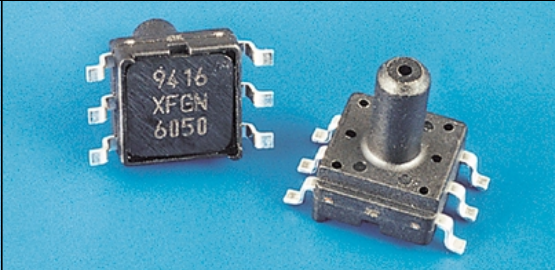
Pressure type	Gauge pressure	
	XFGM-3	XFGM-6
Model		
Package configuration	Surface mount package, 3mm pressure port	Surface mount package, 6mm pressure port

Measurable pressure range (kPa)	Part number for ordering							
	XFGM-3100KPGWSR	XFGM-3100KPGVSRH	XFGMC-3100KPGWSR	XFGMC-3100KPGVSRH	XFGM-6100KPGWSR	XFGM-6100KPGVSRH	XFGMC-6100KPGWSR	XFGMC-6100KPGVSRH
-100~100								
0~-100	XFGM-3100KPGVSR	XFGM-3100KPGVSRH	XFGMC-3100KPGVSR	XFGMC-3100KPGVSRH	XFGM-6100KPGVSR	XFGM-6100KPGVSRH	XFGMC-6100KPGVSR	XFGMC-6100KPGVSRH
0~25	XFGM-3025KPGSR	XFGM-3025KPGSRH	XFGMC-3025KPGSR	XFGMC-3025KPGSRH	XFGM-6025KPGSR	XFGM-6025KPGSRH	XFGMC-6025KPGSR	XFGMC-6025KPGSRH
0~50	XFGM-3050KPGSR	XFGM-3050KPGSRH	XFGMC-3050KPGSR	XFGMC-3050KPGSRH	XFGM-6050KPGSR	XFGM-6050KPGSRH	XFGMC-6050KPGSR	XFGMC-6050KPGSRH
0~100	XFGM-3100KPGSR	XFGM-3100KPGSRH	XFGMC-3100KPGSR	XFGMC-3100KPGSRH	XFGM-6100KPGSR	XFGM-6100KPGSRH	XFGMC-6100KPGSR	XFGMC-6100KPGSRH
0~200	XFGM-3200KPGSR	XFGM-3200KPGSRH	XFGMC-3200KPGSR	XFGMC-3200KPGSRH	XFGM-6200KPGSR	XFGM-6200KPGSRH	XFGMC-6200KPGSR	XFGMC-6200KPGSRH
0~1000	XFGM-3001MPGSR	XFGM-3001MPGSRH	XFGMC-3001MPGSR	XFGMC-3001MPGSRH	XFGM-6001MPGSR	XFGM-6001MPGSRH	XFGMC-6001MPGSR	XFGMC-6001MPGSRH

## Specifications

Model/Rated pressure	100KPGW(H)	100KPGV(H)	025KPG(H)	050KPG(H)	100KPG(H)	200KPG(H)	001MPG(H)	Unit
<b>Recommended operating conditions</b>								
Pressure type	Gauge pressure							—
Rated pressure	$\pm 100$	-100	25	50	100	200	1000	kPa
Rated pressure	$\pm 1.020$	-1.020	0.255	0.510	1.020	2.040	10.20	kg/cm <sup>2</sup>
Measurable pressure range	-100~100	0~-100	0~25	0~50	0~100	0~200	0~1000	kPa
Pressure media ※1	XFGM : Non-corrosive gas only, XFGMC : Non-corrosive gas and liquid							—
Excitation voltage	5.0 $\pm$ 0.25							VDC
<b>Absolute maximum rating</b>								
Maximum load pressure	Twice of rated pressure						1.5times of rated pressure	—
Maximum excitation voltage	8							VDC
Operating temperature	-40~125							°C
Storage temperature	-40~125							°C
Operating humidity	30~80(No dew condensation)							%RH
<b>Electric performances/characteristics (Excitation voltage Vcc=5.0V constant, Ambient temperature Ta=25 °C)</b>								
Current consumption	less than 10							mA
Output impedance	less than 10							$\Omega$
Source current	less than 0.2							mA
Sink current	less than 2							mA
Mechanical response time	2 (For the reference)							msec
Full scale span voltage	4.5							V
Offset voltage ※2	0.2 $\pm$ 0.1125, 0.2 $\pm$ 0.0675(H)							V
Full scale span voltage ※2	4.7 $\pm$ 0.1125, 4.7 $\pm$ 0.0675(H)							V
Accuracy ※2	2.5, $\pm 1.5$ (H)							%FS/0~85°C

Note ; ※1) Please consult us available liquid pressure media when you choose the C models.

※2) Excluding input voltage error.

■ Outline dimensions ■

unit : mm

XFGM-3

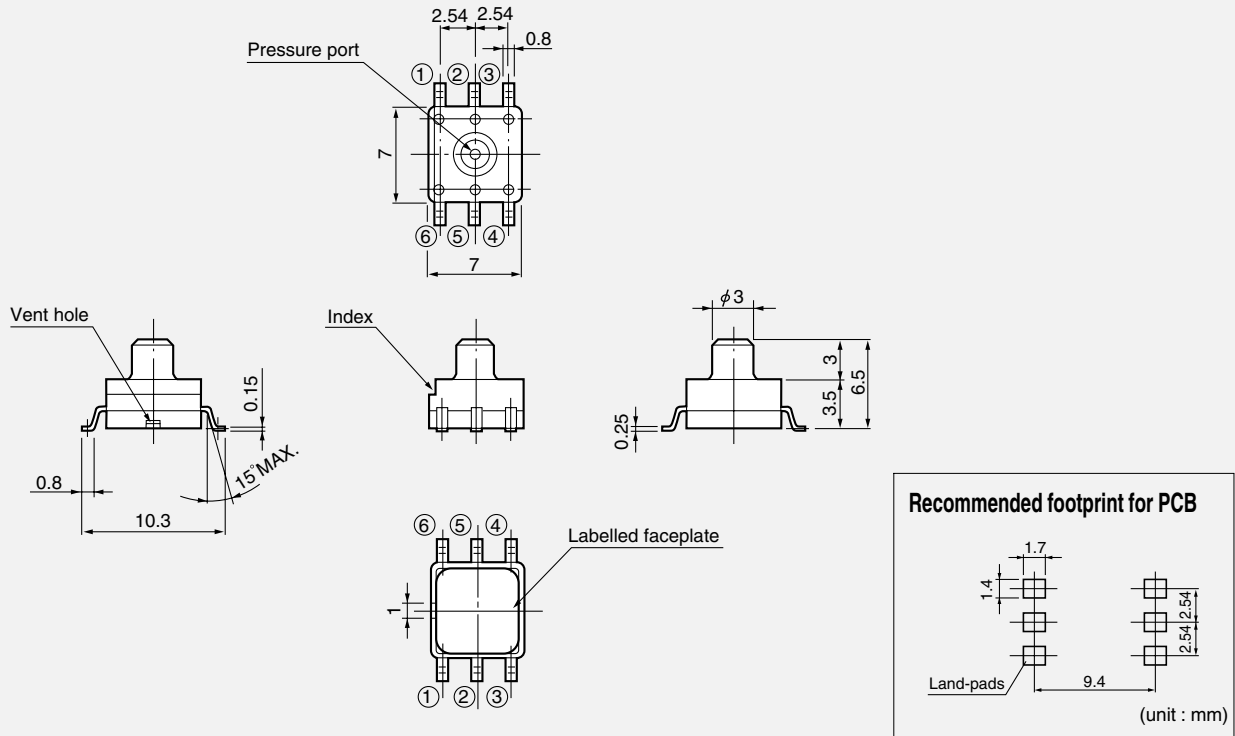

XFGM-6

unit : mm

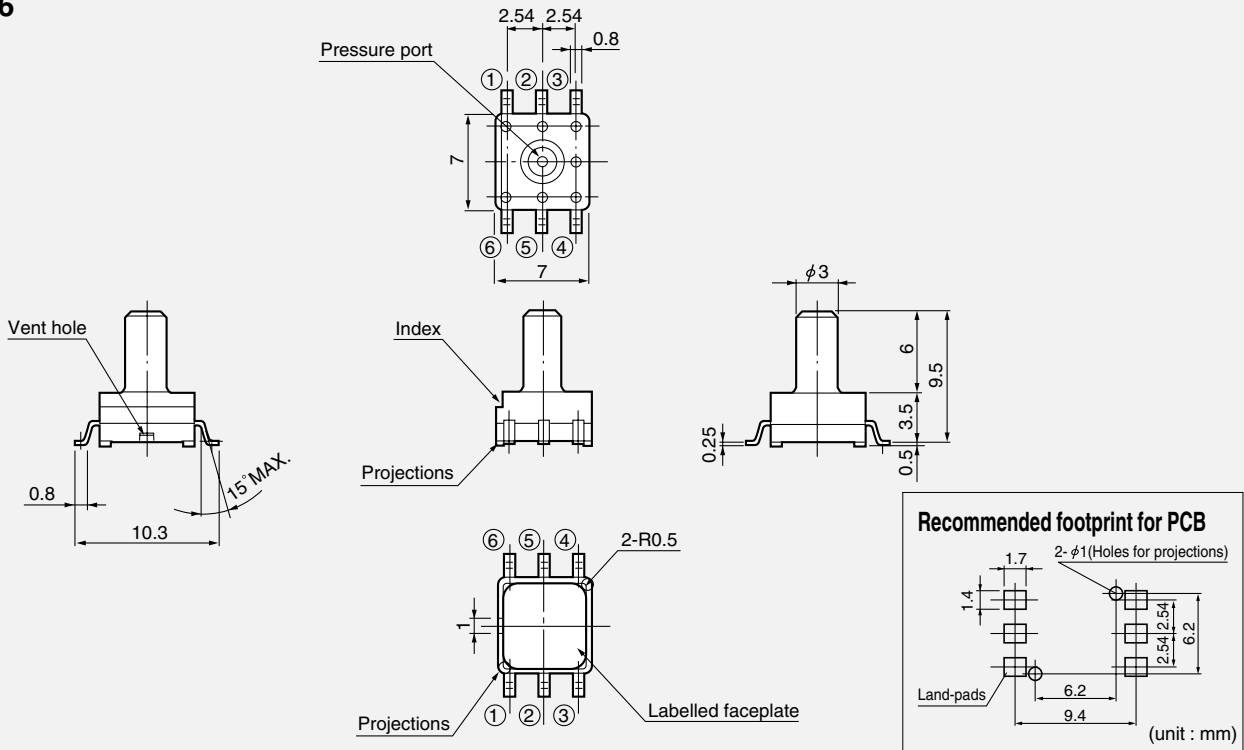

### ■ Connection diagram ■

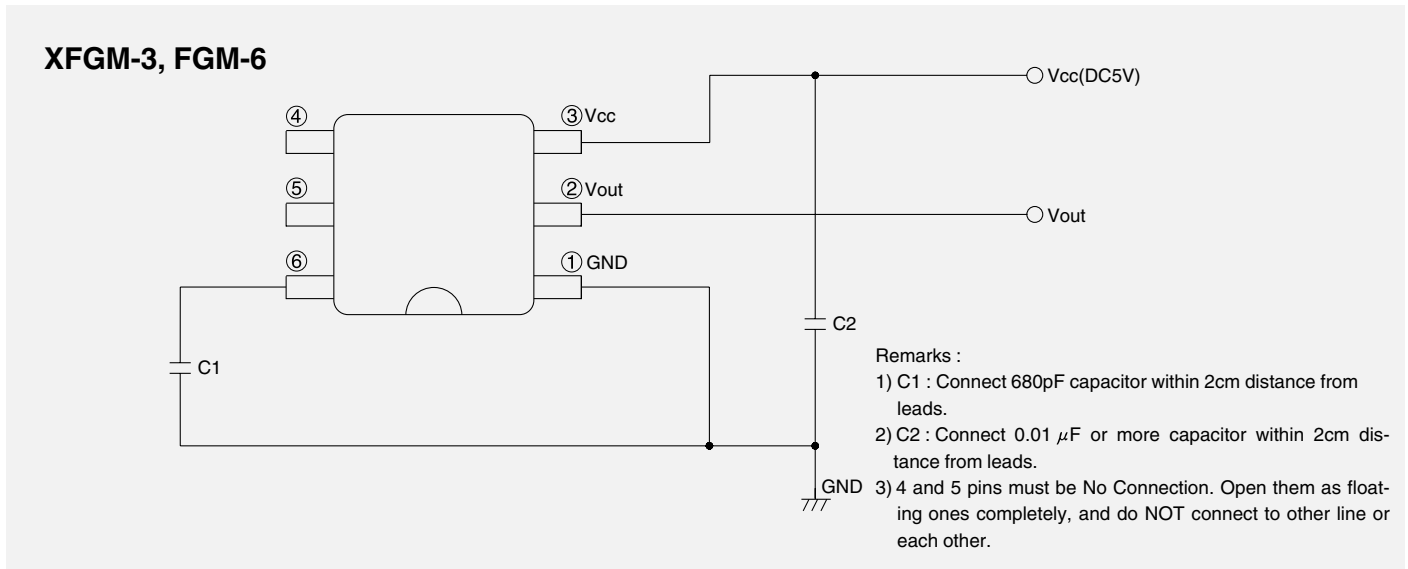

Note ; Please read instruction "Notes" before using the sensor.  
Fujikura reserves the right to change specifications without notice.

## Fujikura Ltd.

If you have any questions regarding technical issues or specifications, please contact us.  
Sensor Engineering Department 5-1 Kiba 1-chome, Koto-ku, Tokyo 135-8512, Japan  
Phone +81-(0)3-5606-1072 Fax. +81-(0)3-5606-1538  
E-mail : sensor@fujikura.co.jp