



Model Number

WTS10-12-4016/103/105

Diffuse mode sensor
with 5-pin, M12 x 1 connector

Features

- Specifically for quality checks on welding caps
- Upper and lower welding caps checked simultaneously
- High position and angle tolerance insensitive of the welding cap
- Pre-fault indication
- Scratch resistant mineral glass lens

Product information

The welding tip sensor WTS10 series is a contrast evaluation sensor with a large and homogeneous light spot fitted to check the quality of the welding cap's face after milling of the welding tip and which is widely used for industrial welding robots.

After the milling process of the welding cap, both tips of the welding gun are inspected and defects such as inclusions, faulty milling or burrs are detected.

Simultaneous control of the quality of both welding tip caps with one sensor is possible by providing two optical outputs on either side of the sensor housing.

The WTS10 features an extended detection area of 11 mm diameter, an uniform lightspot over the full sensing range due to coaxial optics beam path, a new display concept, high switching accuracy, a homogenous light spot and improved position and tilting angle tolerance.

Dimensions

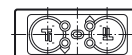
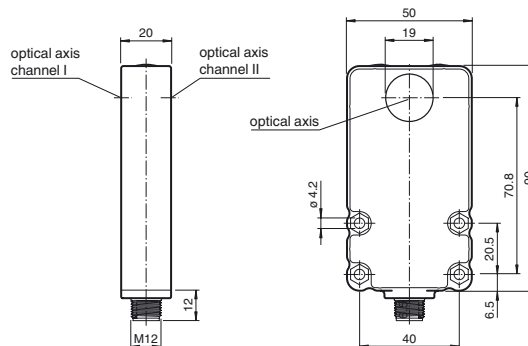

Electrical connection

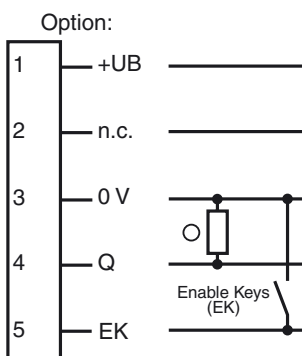

○ = Light on
● = Dark on

Pinout

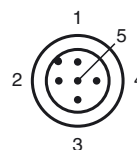

Indicators/operating means

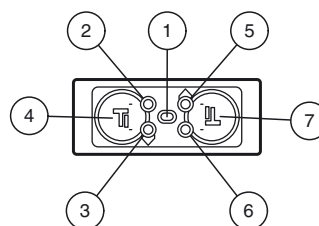

1	LED Power On	green
2	LED channel I	red
3	LED channel I	yellow
4	Teach-In channel I	
5	LED channel II	yellow
6	LED channel II	red
7	Teach-In channel II	

Release date: 2011-02-11 13:03 Date of issue: 2011-02-11 207057_ENG.xml

Subject to modifications without notice

Pepperl+Fuchs Group
www.pepperl-fuchs.com

USA: +1 330 486 0001
fa-info@us.pepperl-fuchs.com

Germany: +49 621 776-4411
fa-info@pepperl-fuchs.com

Copyright Pepperl+Fuchs
Singapore: +65 6779 9091
fa-info@sg.pepperl-fuchs.com

Technical data**General specifications**

Detection range	2 ... 12 mm
Reference target	Copper welding-electrode Diameter: 16 mm , Front end: 6 mm
Light source	LED
Light type	modulated visible red light , 640 nm
Ambient light limit	continuous light 40000 Lux , Modulated light 5000 Lux
Tilting angle	± 1.5 °
Position tolerance	± 2 mm

Indicators/operating means

Operating display	LED green: Power on
Function display	LED yellow: switching state LED red: Pre-fault indication
TEACH-IN indication	LED, green/yellow flashing (approx. 4 Hz) Teach Error:LED green/yellow non equiphase flashing; 8.0 Hz
Controls	TEACH-IN key

Electrical specifications

Operating voltage	U_B	10 ... 30 V DC
No-load supply current	I_0	≤ 70 mA

Input

Function input	Enable keys (EK)
----------------	------------------

Output

Switching type	light on
Signal output	switch output PNP, NO AND logic coupling of both sensor channels short-circuit protected reverse polarity protected
Switching current	max. 100 mA
Switching frequency	f 100 Hz
Response time	5 ms

Ambient conditions

Ambient temperature	0 ... 50 °C (32 ... 122 °F) The switching accuracy will remain, if the temperature after Teach-In does not varies more than ±7 °C
Storage temperature	-20 ... 70 °C (-4 ... 158 °F)

Mechanical specifications

Protection degree	IP67
Connection	M12 x 1 connector, 5-pin
Material	
Housing	PC + ABS
Optical face	Scratch resistant mineral glass lens
Mass	80 g

Compliance with standards and directives

Standard conformity	
Product standard	EN 60947-5-2:2007 IEC 60947-5-2:2007
Shock and impact resistance	IEC / EN 60068. half-sine, 50 g in each X, Y and Z directions
Vibration resistance	IEC / EN 60068-2-6. Sinus. 10 -150 Hz, 5 g in each X, Y and Z directions

Approvals and certificates

Protection class	II, rated voltage ≤ 250 V AC with pollution degree 1-2 according to IEC 60664-1
UL approval	cULus Listed
CCC approval	Products with a maximum operating voltage of ≤36 V do not bear a CCC marking because they do not require approval.

Accessories**OMH-WTS10-01**

Mounting bracket for sensors of WTS10 series

V15-G-0,3M-PUR-V1-G-WTS-PROG

Connection cable for WTS programming, M12 to M12, irradiated PUR cable, 4/5-pin

V15-G-2M-PVC

Cable socket, M12, 5-pin, PVC cable

V15-G-2M-PUR

Cable socket, M12, 5-pin, PUR cable

V15-W-5M-PVC

Cable socket, M12, 5-pin, PVC cable

V15-W-5M-PUR

Cable socket, M12, 5-pin, PUR cable

Other suitable accessories can be found at www.pepperl-fuchs.com

Curves/Diagrams

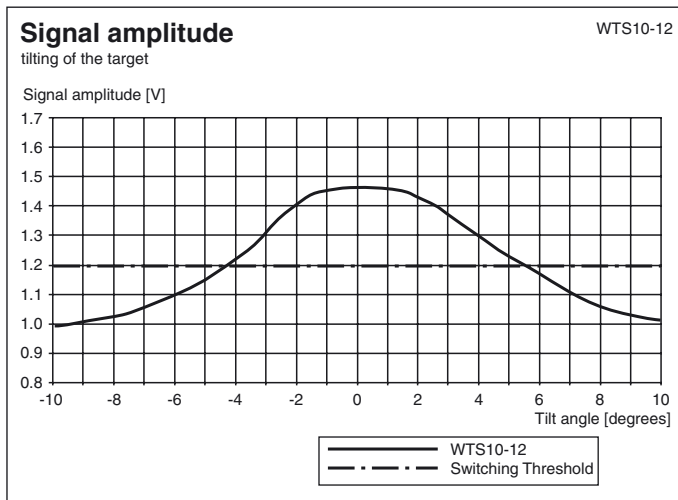
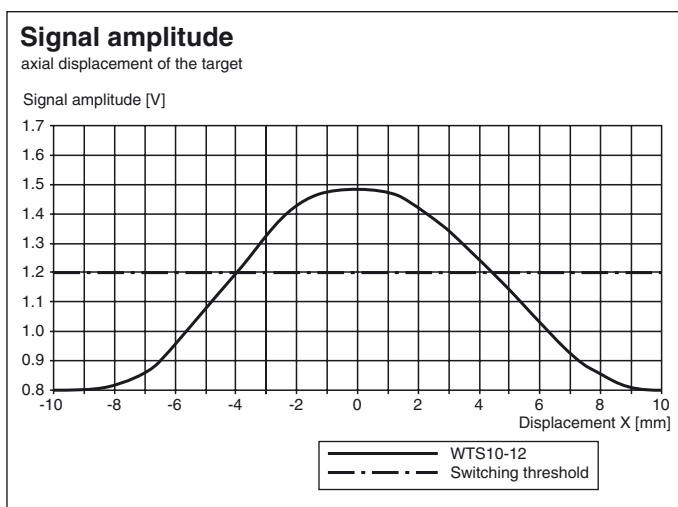
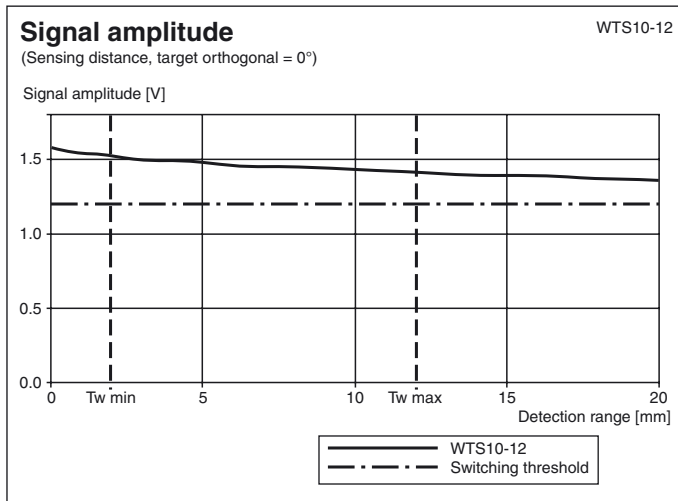

Teach-In

- To enable the Teach-In keys, pin 5 (enable keys, EK) must be continuously connected to 0 V (bridge between pin 5 and pin 3).
- Position the reference welding cap in front of the lens of the desired sensor channel (channel I or channel II).
- Hold down the corresponding Teach-In key.
The sensor confirms the key being pressed by briefly turning off the green indicator LED (200 ms).
- After 2 seconds, the sensor switches back to Teach-In mode:
The switching output are deactivated.
The correctly milled welding cap acts as a reference sample to teach in the sensor for the selected sensor channel.
The green LED and the yellow LED corresponding to the selected sensor channel flash in phase.
You can now release the Teach-In key.
- Teach-In completed:
The green LED and the yellow LED corresponding to the selected sensor channel flash out of phase for 2 seconds.

Release date: 2011-02-11 13:03 Date of issue: 2011-02-11 207057_ENG.xml

- **Teach-In OK:**

The reference welding cap that was taught in is saved in permanent memory.
The sensor switches back to switching mode.

- **Teach-In error:**

Error is indicated by rapid out of phase flashing of the green LED and the yellow LED corresponding to the selected sensor channel (approx. 8 Hz) for 5 seconds.

Teach-In values are discarded by the sensor. After 5 seconds, the sensor switches back to switching mode and works with the most recent valid values.

For signal levels below the fixed switching threshold value, the Teach-In mode can't be entered. A Teach-In error is indicated.