

PTC-Resistor-Relay Type MS(R)220Vi

Atex-Approval according to Directive 2014/34/EU, intrinsic safe input

MS220Vi



PTC-relay for the application as a protection device against inadmissible heating up at electrical equipment in areas with explosive gases (zones 0, 1 and 2) and in areas with combustible dust (zones 20, 21 and 22), e.g. for direct monitoring in explosion-protected areas where intrinsic safety class "i" is afforded. PTC-Sensors (Thermistors) of intrinsic safety class "i" can be connected directly. The sensors may be placed in the potentially explosive atmosphere, e.g. for mechanical explosion-protection at bearings. The relay itself may not be installed in the potentially explosive atmospheres.

- Connection for temperature sensor with intrinsic safety ignition protection type Ex ia IIC and Ex iaD
- ATEX-approval according to directive 2014/34/EU
- Safety Integrity Level SIL 1
- 1 PTC-resistor set (thermistors), each 1...6 PTC
- Short-circuit monitoring of sensor-circuit
- Output-relay with 2 change-over contacts
- LEDs for ON and ALARM
- Housing for mounting in switchgear-cabinet, 70 mm wide, mounting height 55 mm
- Assembly on DIN-rail 35 mm or screws M4
- Option:
other supply-voltages

Order-number:
AC 220-240 V **T222185**

Ex II (1) GD [Ex ia] IIC [Ex iaD]

MSR220Vi

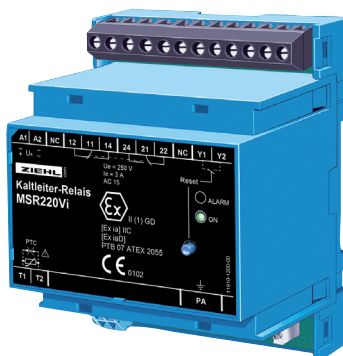

Same execution as MS220Vi, additionally with electronic reclosing lock. An alarm is stored until a reset is made.

- ATEX-approval according to directive 2014/34/EU
- Electronic reclosing lock (disconnectable)
- Integrated RESET-button
- Link for external reset
- Automatic reset at voltage recovery
- Option:
other supply-voltages

Order-numbers:
AC 220-240 V **T222195**
AC/DC 24 V **T222191**

Ex II (1) GD [Ex ia] IIC [Ex iaD]

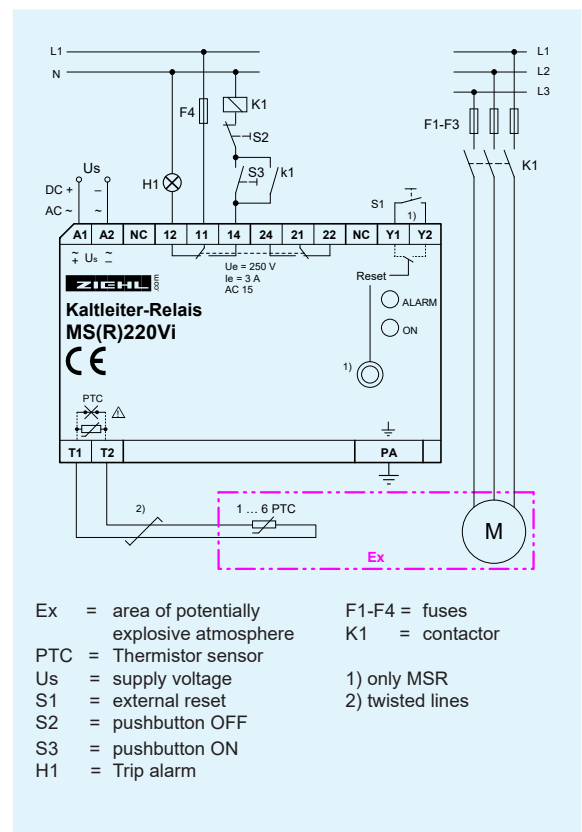

Technical Data

Rated supply-voltage U_s	AC 220 - 240 V \pm 10 % 50/60 Hz \leq 2 VA AC/DC 24 V, AC \pm 10 % DC 21- 30 V $<$ 2 VA, without potential separation
Connectable PTC-resistors Switching point	1...6 in series according to DIN 44081 or 44082 $<$ 4000 Ω
Output relay Type of contact	2 change-over contacts (co) type 2, see "general technical information"
Test conditions Rated ambient temp. range	see "general technical information" -20...+60 $^{\circ}$ C
Dimensions (H x W x D) Attachment Protection housing/terminals Weight	Design V4: 90 x 70 x 58 mm, mounting height 55 mm on 35 mm rail according to EN 60 715 or screws M4 IP 30 / IP 20 app. 180 g

1

