

Current Transducer HTRS series

$I_{PN} = 10, 30, 50 \text{ A}$

Ref: HTRS 10-SBI, HTRS 30-SBI, HTRS 50-SBI

For the electronic measurement of current: DC, AC, pulsed..., with galvanic separation between the primary and the secondary circuit.

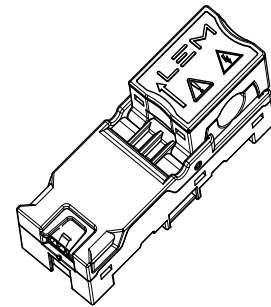

Features

- Open loop current transducer using the Hall effect
- Panel mounting
- Split core design for easy installation
- Insulating plastic case recognized according to UL 94-V0
- Reverse polarity protected.

Advantages

- Easy mounting
- Small size and space saving
- No insertion losses
- Non-contact measurement (doesn't need a safety case).

Applications

- Points condition monitoring
- Signal light indication
- Battery supplied applications
- Uninterruptable Power Supplies (UPS).

Standards

- UL508 : 2010
- EN 50121-4 : 2015 ¹⁾
- EN 50124-1 : 2017
- EN 50125-3 : 2003
- IEC 61000-6-4:2018.

Application Domain

- Track side.

Note:

¹⁾ Immunity to "Radio-frequency electromagnetic field", according to EN 61000-4-3, is used shield wire with both ends of shielding layer ground.

Safety



Caution

If the device is used in a way that is not specified by the manufacturer, the protection provided by the device may be compromised. Always inspect the electronics unit and connecting cable before using this product and do not use it if damaged. Mounting assembly shall guarantee the maximum primary conductor temperature, fulfill clearance and creepage distance, minimize electric and magnetic coupling, and unless otherwise specified can be mounted in any orientation.



Caution, risk of electrical shock

This transducer must be used in limited-energy secondary circuits SELV according to IEC 61010-1, in electric/electronic equipment with respect to applicable standards and safety requirements in accordance with the manufacturer's operating specifications.

Use caution during installation and use of this product; certain parts of the module can carry hazardous voltages and high currents (e.g. power supply, primary conductor).

Ignoring this warning can lead to injury and/or cause serious damage.

De-energize all circuits and hazardous live parts before installing the product.

All installations, maintenance, servicing operations and use must be carried out by trained and qualified personnel practicing applicable safety precautions.

This transducer is a build-in device, whose hazardous live parts must be inaccessible after installation.

This transducer must be mounted in a suitable end-enclosure.

Besides make sure to have a distance of minimum 30 mm between the primary terminals of the transducer and other neighboring components.

Main supply must be able to be disconnected.

Always inspect the flexible probe for damage before using this product.

Never connect or disconnect the external power supply while the primary circuit is connected to live parts.

Never connect the output to any equipment with a common mode voltage to earth greater than 30 V.

Always wear protective clothing and gloves if hazardous live parts are present in the installation where the measurement is carried out.

This transducer is a built-in device, not intended to be cleaned with any product. Nevertheless if the user must implement cleaning or washing process, validation of the cleaning program has to be done by himself.

When defining soldering process, please use no cleaning process only.

Do not dispose of this product as unsorted municipal waste. Contact a qualified recycler for disposal.

Absolute maximum ratings

Parameter	Symbol	Unit	Value
Maximum supply voltage (working) (-40 ... +85 °C)	$U_{C \max}$	V	26
Maximum primary conductor temperature	$T_{B \max}$	°C	90

Absolute maximum ratings apply at 25 °C unless otherwise noted.
 Stresses above these ratings may cause permanent damage.
 Exposure to absolute maximum ratings for extended periods may degrade reliability.

Environmental and mechanical characteristics

Parameter	Symbol	Unit	Min	Typ	Max	Comment
Ambient operating temperature	T_A	°C	-40		85	
Ambient storage temperature	$T_{A \text{st}}$	°C	-40		85	
Mass	m	g		35		
Ingress protection rating				IP40		According to IEC 60529

Insulation coordination

Parameter	Symbol	Unit	≤ Value	Comment
RMS voltage for AC insulation test, 50 Hz, 1 min	U_d	kV	6	
Impulse withstand voltage 1.2/50 μ s	U_{Ni}	kV	11	
Partial discharge RMS test voltage ($q_m < 10$ pC)	U_t	V	1537	
Clearance (pri. - PCBA.)	d_{Cl}	mm	12.7	Shortest distance through air from primary to PCBA
Creepage distance (pri. - PCBA.)	d_{Cp}	mm	12.7	Shortest path along device body from primary to PCBA
Case material	-	-	V0	According to UL 94
Comparative tracking index	CTI	V	250	
Application example RMS voltage line-to-neutral		V	1270	Basic insulation according to IEC 50124-1 CAT II, PD2
Application example RMS voltage line-to-neutral		V	600	Reinforced insulation according to IEC 50124-1 CAT II, PD2

Electrical data of HTRS 10-SBI

At $T_A = 25\text{ °C}$, $U_C = 24\text{ V}$, $N_p = 1$ turn, unless otherwise noted (see "Definition of typical, minimum and maximum values" paragraph, see page 8).

Parameter	Symbol	Unit	Min	Typ	Max	Comment
Primary nominal RMS current	I_{PN}	A		10		
Primary current, measuring range	I_{PM}	A	-20		20	
Measuring resistance	R_M	Ω	50	100	250	
Output current	I_{out}	mA	4		20	details see figure 1
Output current @ $I_p = 0\text{ A}$	I_{out}	mA		12		
DC supply voltage	U_C	V	11.5	24	26	
DC current consumption ¹⁾	I_C	mA			50	
Error ^{2) 3)}	ε	% of I_{PN}	-2		2	
Error @ $T_A = 85\text{ °C}$ ^{2) 3)}	ε	% of I_{PN}	-3		3	
Error @ $T_A = -40\text{ °C}$ ^{2) 3)}	ε	% of I_{PN}	-3		3	
Electrical offset current	I_{OE}	mA	-0.1		0.1	
Temperature coefficient of I_{OE}	TCI_{OE}	mA/K	-0.002		0.002	
Magnetic offset current (@ $3 \times I_{PN}$)	I_{OM}	mA	-0.04		0.04	
Sensitivity	S	mA/A		0.4		
Sensitivity error	ε_S	% of I_{PN}	-1.8		1.8	factory adjustment
Temperature coefficient of S	TCS	% of I_{PN}/K	-0.017		0.017	
Linearity error	ε_L	% of I_{PN}	-0.5		0.5	
RMS noise voltage DC to 10 kHz	U_{no}	mVpp		15		with $R_L = 100\text{ohm}$
Delay time to 10 % of the final output value for I_{PN} step ⁴⁾	t_{D10}	μs			10	
Delay time to 90 % of the final output value for I_{PN} step ⁴⁾	t_{D90}	μs			20	
Frequency bandwidth (-3 dB)	BW	KHz	30			

Notes: ¹⁾ Including I_{out}

²⁾ Excludes electrical offset

³⁾ Includes linearity with the conductor in the center of the aperture

⁴⁾ For a $di/dt = 30\text{ A}/\mu\text{s}$.

Electrical data of HTRS 30-SBI

At $T_A = 25\text{ °C}$, $U_C = 24\text{ V}$, $N_P = 1$ turn, unless otherwise noted (see "Definition of typical, minimum and maximum values" paragraph, see page 8).

Parameter	Symbol	Unit	Min	Typ	Max	Comment
Primary nominal RMS current	I_{PN}	A		30		
Primary current, measuring range	I_{PM}	A	-60		60	
Measuring resistance	R_M	Ω	50	100	250	
Output current	I_{out}	mA	4		20	details see figure 1
Output current @ $I_P = 0\text{ A}$	I_{out}	mA		12		
DC supply voltage	U_C	V	11.5	24	26	
DC current consumption ¹⁾	I_C	mA			50	
Error ²⁾³⁾	ε	% of I_{PN}	-2		2	
Error @ $T_A = 85\text{ °C}$ ²⁾³⁾	ε	% of I_{PN}	-3		3	
Error @ $T_A = -40\text{ °C}$ ²⁾³⁾	ε	% of I_{PN}	-3		3	
Electrical offset current	I_{OE}	mA	-0.1		0.1	
Temperature coefficient of I_{OE}	TCl_{OE}	mA/K	-0.002		0.002	
Magnetic offset current (@ $3 \times I_{PN}$)	I_{OM}	mA	-0.04		0.04	
Sensitivity	S	mA/A		4/30		
Sensitivity error	ε_S	% of I_{PN}	-1.8		1.8	factory adjustment
Temperature coefficient of S	TCS	% of I_{PN}/K	-0.017		0.017	
Linearity error	ε_L	% of I_{PN}	-0.5		0.5	
RMS noise voltage DC to 10 kHz	U_{no}	mVpp		15		with $R_L = 100\text{ohm}$
Delay time to 10 % of the final output value for I_{PN} step ⁴⁾	t_{D10}	μs			10	
Delay time to 90 % of the final output value for I_{PN} step ⁴⁾	t_{D90}	μs			20	
Frequency bandwidth (-3 dB)	BW	KHz	30			

Notes: ¹⁾ Including I_{out}

²⁾ Excludes electrical offset

³⁾ Includes linearity with the conductor in the center of the aperture

⁴⁾ For a $di/dt = 30\text{ A}/\mu\text{s}$.

Electrical data of HTRS 50-SBI

At $T_A = 25\text{ °C}$, $U_C = 24\text{ V}$, $N_P = 1$ turn, unless otherwise noted (see "Definition of typical, minimum and maximum values" paragraph, see page 8).

Parameter	Symbol	Unit	Min	Typ	Max	Comment
Primary nominal RMS current	I_{PN}	A		50		
Primary current, measuring range	I_{PM}	A	-100		100	
Measuring resistance	R_M	Ω	50	100	250	
Output current	I_{out}	mA	4		20	details see figure 1
Output current @ $I_P = 0\text{ A}$	I_{out}	mA		12		
DC supply voltage	U_C	V	11.5	24	26	
DC current consumption ¹⁾	I_C	mA			50	
Error ²⁾³⁾	ε	% of I_{PN}	-2		2	
Error @ $T_A = 85\text{ °C}$ ²⁾³⁾	ε	% of I_{PN}	-3		3	
Error @ $T_A = -40\text{ °C}$ ²⁾³⁾	ε	% of I_{PN}	-3		3	
Electrical offset current	I_{OE}	mA	-0.1		0.1	
Temperature coefficient of I_{OE}	TCl_{OE}	mA/K	-0.002		0.002	
Magnetic offset current (@ $3 \times I_{PN}$)	I_{OM}	mA	-0.04		0.04	
Sensitivity	S	mA/A		0.08		
Sensitivity error	ε_S	% of I_{PN}	-1.8		1.8	factory adjustment
Temperature coefficient of S	TCS	% of I_{PN}/K	-0.017		0.017	
Linearity error	ε_L	% of I_{PN}	-0.5		0.5	
RMS noise voltage DC to 10 kHz	U_{no}	mVpp		15		with $R_L = 100\text{ohm}$
Delay time to 10 % of the final output value for I_{PN} step ⁴⁾	t_{D10}	μs			10	
Delay time to 90 % of the final output value for I_{PN} step ⁴⁾	t_{D90}	μs			20	
Frequency bandwidth (-3 dB)	BW	KHz	30			

Notes: ¹⁾ Including I_{out}

²⁾ Excludes electrical offset

³⁾ Includes linearity with the conductor in the center of the aperture

⁴⁾ For a $di/dt = 30\text{ A}/\mu\text{s}$.

Definition of typical, minimum and maximum values

Minimum and maximum values for specified limiting and safety conditions have to be understood as such as well as values shown in “typical” graphs.

On the other hand, measured values are part of a statistical distribution that can be specified by an interval with upper and lower limits and a probability for measured values to lie within this interval.

Unless otherwise stated (e.g. “100 % tested”), the LEM definition for such intervals designated with “min” and “max” is that the probability for values of samples to lie in this interval is 99.73 %.

For a normal (Gaussian) distribution, this corresponds to an interval between -3 sigma and $+3$ sigma. If “typical” values are not obviously mean or average values, those values are defined to delimit intervals with a probability of 68.27 %, corresponding to an interval between $-\text{sigma}$ and $+\text{sigma}$ for a normal distribution.

Typical, maximal and minimal values are determined during the initial characterization of the product.

Typical performance characteristics

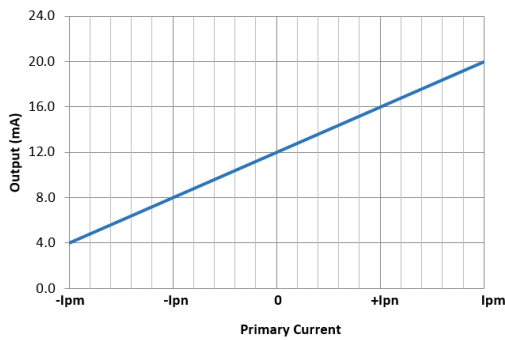

Figure 1: Transfer characteristics

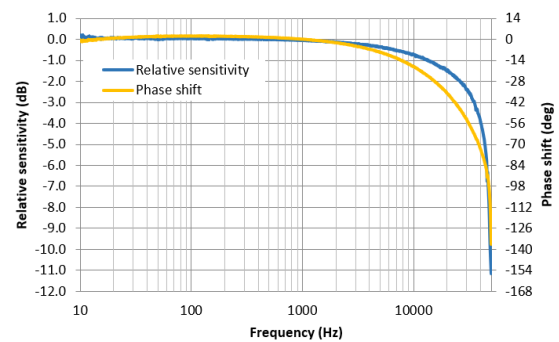

Figure 2: Frequency response

Terms and definitions

Ampere-turns and amperes

The transducer is sensitive to the primary current linkage θ_p (also called ampere-turns).

$$\theta_p = N_p \cdot I_p$$

Where N_p is the number of primary turn (depending on the connection of the primary jumpers).

Caution: As most applications will use the transducer with only one single primary turn ($N_p = 1$), much of this datasheet is written in terms of primary current instead of current linkages. However, the ampere-turns (A) unit is used to emphasis that current linkages are intended and applicable.

Simplified transducer model

The static model of the transducer with current output at temperature T_A is:

$$I_{out} = S \cdot \theta_p \cdot (1 + \varepsilon)$$

In which (referred to primary):

$$\varepsilon \cdot \theta_p = I_{OE} + I_{OT} + \varepsilon_s \cdot \theta_p + \varepsilon_{sT} \cdot \theta_p + \varepsilon_L(\theta_{Pmax}) \cdot \theta_{Pmax} + I_{OM}$$

- $\theta_p = N_p \cdot I_p$: primary current linkage (A)
- θ_{Pmax} : maximum primary current linkage applied to the transducer
- I_{out} : Output current (A)
- S : sensitivity of the transducer
- T_A : ambient operating temperature (°C)
- I_{OE} : electrical offset current (A)
- I_{OM} : magnetic offset current (A)
- I_{OT} : temperature variation of I_{OE} (A)
- ε_s : sensitivity error at 25 °C
- ε_{sT} : thermal drift of S
- $\varepsilon_L(\theta_{Pmax})$: linearity error for θ_{Pmax}

This model is valid for primary ampere-turns θ_p between $-\theta_{Pmax}$ and $+\theta_{Pmax}$ only.

This is the absolute maximum error. As all errors are independent, a more realistic way to calculate the error would be to use the following formula:

$$\varepsilon = \sqrt{\sum_{i=1}^N \varepsilon_i^2}$$

Total error referred to primary

The total error ε_{tot} is the error at $\pm I_{PN}$, relative to the rated value I_{PN} .

It includes all errors mentioned above

- the electrical offset I_{OE}
- the magnetic offset I_{OM}
- the sensitivity error ε_s
- the linearity error ε_L (to I_{PN}).

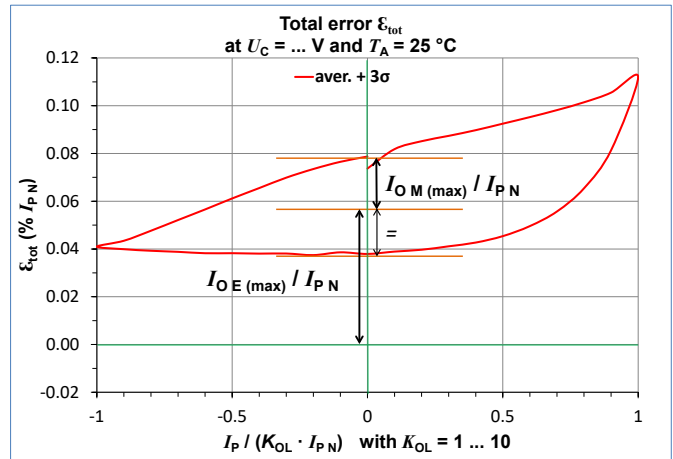

Figure 3: Total error ε_{tot}

Electrical offset referred to primary

Using the current cycle shown in figure 3, the electrical offset current I_{OE} is the residual output referred to primary when the input current is zero.

$$I_{OE} = \frac{I_{P(3)} + I_{P(5)}}{2}$$

The temperature variation I_{OT} of the electrical offset current I_{OE} is the variation of the electrical offset from 25 °C to the considered temperature.

$$I_{OT}(T) = I_{OE}(T) - I_{OE}(25^\circ\text{C})$$

Magnetic offset referred to primary

The magnetic offset current I_{OM} is the consequence of a current on the primary side ("memory effect" of the transducer's ferromagnetic parts). It is measured using the following primary current cycle. I_{OM} depends on the current value $I_p \geq I_{PN}$.

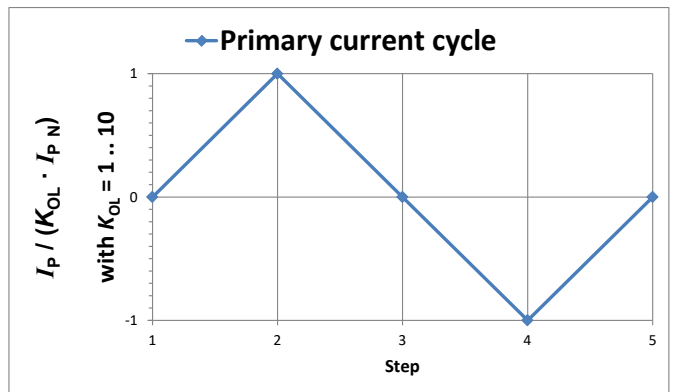

K_{OL} : Overload factor

Figure 4: Current cycle used to measure magnetic and electrical offset (transducer supplied)

$$I_{OM} = \frac{I_{P(3)} - I_{P(5)}}{2}$$

Performance parameters definition

Sensitivity and linearity

To measure sensitivity and linearity, the primary current (DC) is cycled from 0 to I_P , then to $-I_P$ and back to 0 (equally spaced $I_P/10$ steps). The sensitivity S is defined as the slope of the linear regression line for a cycle between $\pm I_{PN}$.

The linearity error ϵ_L is the maximum positive or negative difference between the measured points and the linear regression line, expressed in % of I_{PN} .

Delay times

The delay time t_{D10} @ 10 % and the delay time t_{D90} @ 90 % with respect to the primary are shown in the next figure.

Both slightly depend on the primary current di/dt . They are measured at nominal current.

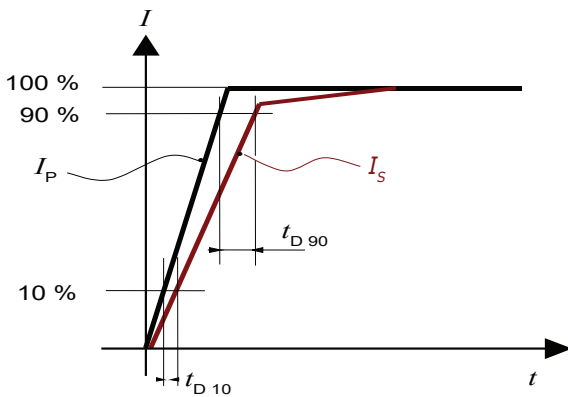
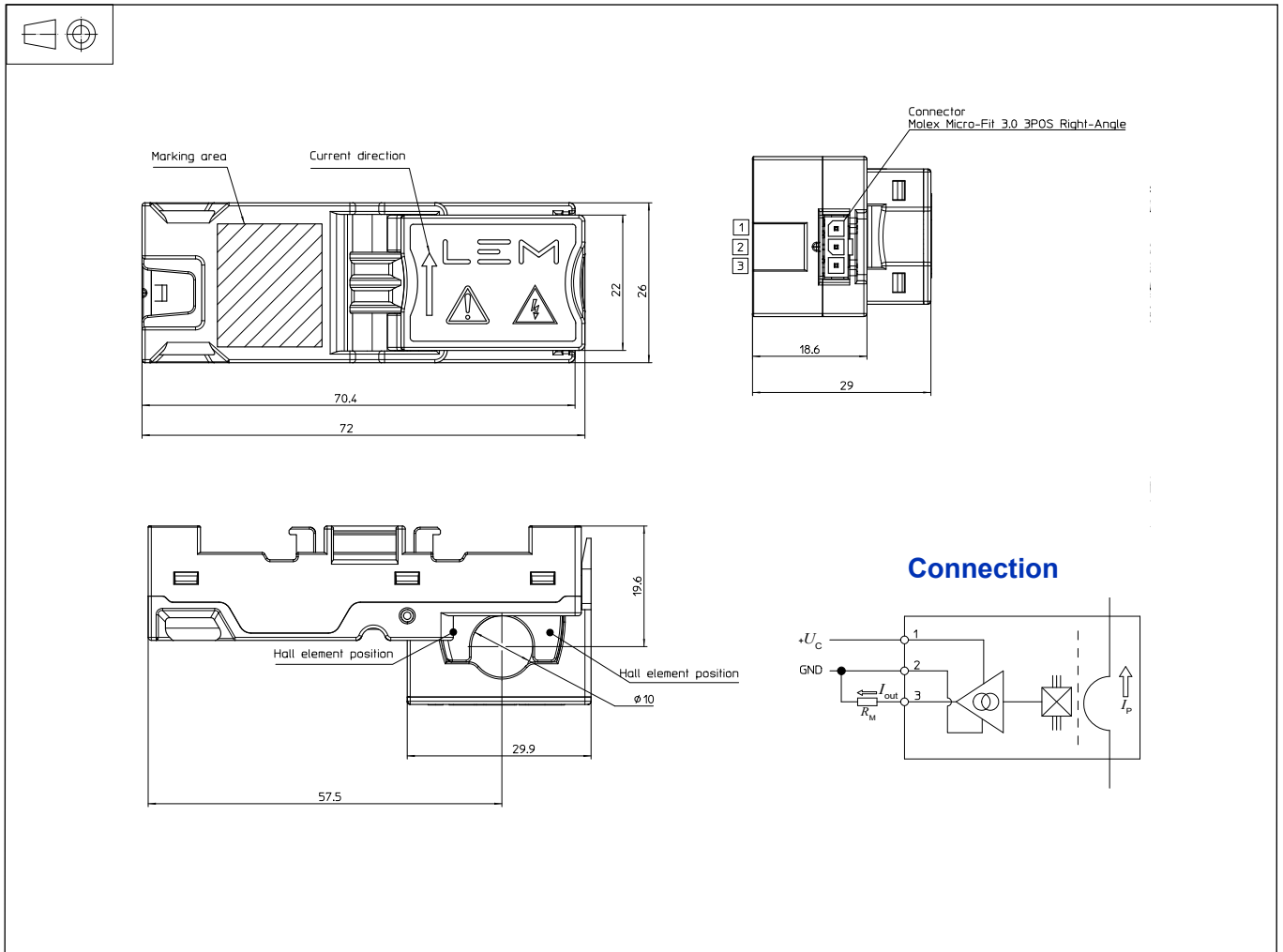

Figure 5: t_{D10} (delay time @ 10 %) and t_{D90} (delay time @ 90 %).

Dimensions (in mm)



Mechanical characteristics

- General tolerance ± 0.5 mm
- Transducer fastening $\varnothing 4.3$ mm
- Recommended fastening torque 1.5 N·m
- Connection of secondary MOLEX 436500300

Remarks

- I_S is positive when I_p flows in the direction of arrow.
- The secondary cables also have to be routed together all the way.
- Installation of the transducer must be done, unless otherwise specified on the datasheet, according to LEM Transducer Generic Mounting Rules. Please refer to LEM document N°ANE120504 available on our Web site: <https://www.lem.com/en/file/3137/download/>.

Installation information

Assembly recommendation :
HTRS assembly with screw plate. The plate could fix product in 2 alternative directions (in parallel or vertical of the current direction)

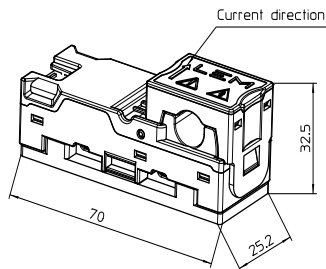

Screw plate fastening: 2 holes or notches ϕ 9mm (2 steel screws M4)
- Recommended fastening torque ($\pm 10\%$): 1.5 N.m

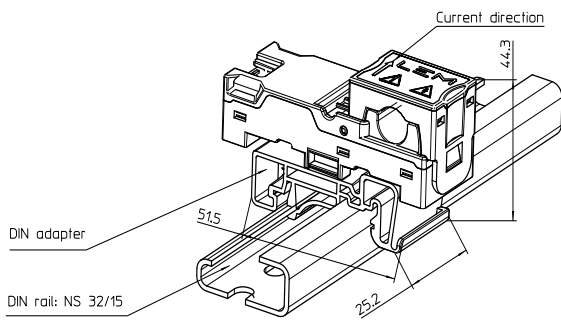
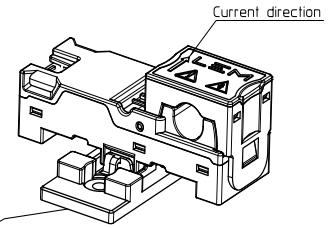
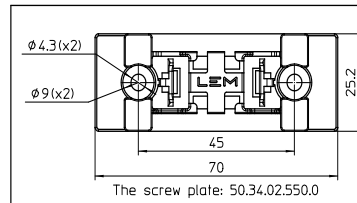

Assembly recommendation :
HTRS assembly with DIN adapter (50.34.02.549.0).
The adapter could fix product in 2 alternative directions
(in parallel or vertical of the current direction)
The DIN category: NS 32/15 and NS 35/7.5

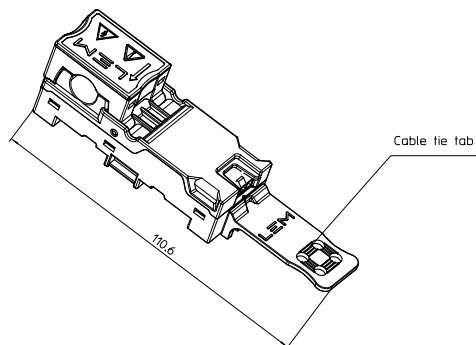
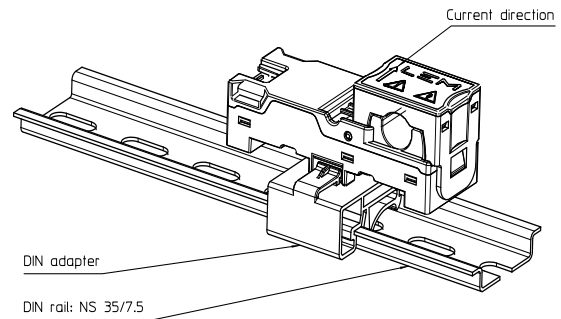

Cable tie tab (50.34.02.551.0) is optional accessories,
which is serve for output cable collection.