

Data sheet for SIMOTICS S-1FK2

Article No. : 1FK2105-6AF11-1MA0



Figure similar

Client order no. :
Order no. :
Offer no. :
Remarks :

Item no. :
Consignment no. :
Project :

Basic motor data

Motor type	Permanent-magnet synchronous motor, Natural cooling, IP65
Motor type	High Dynamic
Static torque	8.00 Nm
Static current	6.7 A
Maximum torque	24.00 Nm
Maximum current	24.0 A
Maximum speed	6,000 rpm
Rotor moment of inertia	3.5000 kgcm ²
Weight	8.7 kg

Rated data

SINAMICS S210, 3AC 400V

Rated speed	3,000 rpm
Rated torque	6.60 Nm
Rated current	5.6 A
Rated power	2.10 kW

Encoder system

Encoder system	Encoder AM22DQC: Absolute encoder 22 bit + 12 bit multiturn
----------------	---

Motor connection

Connection type	OCC for S210
Connector size	M17

Mechanical data

Design acc. to Code I	IM B5 (IM V1, IM V3)
Vibration severity grade	Grade A
Shaft height	52
Flange size (AB)	105 mm
Centering ring (N)	95 mm
Hole circle (M)	115 mm
Screw-on hole (S)	9.0 mm
Overall length (LB)	242 mm
Diameter of shaft (D)	19 mm
Length of shaft (E)	40 mm
Length of flange diagonal (P)	135 mm
Shaft end	Fitted key
Color of the housing	Standard (Anthracite, similar to RAL 7016)

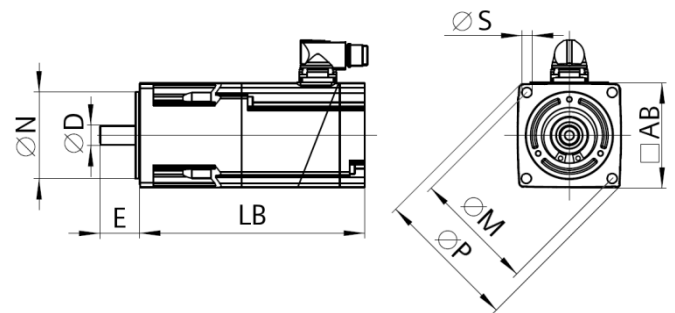

Holding brake

Holding torque	8.00 Nm
Average dynamic torque	5.00 Nm
Opening time	35 ms
Closing time	20 ms
Maximum single switching energy ¹⁾	570 J
Service life, operating energy	284,000 J
Holding current ²⁾	0.3 A
Break-induced current for 500 ms ²⁾	1.1 A

¹⁾Up to three consecutive emergency stops and up to 25% of all emergency stops as a Wmax high energy stop possible.

²⁾Typical value for 20°C ambient temperature. At -15°C the break-induced currents can be increased by up to 30%.