

Static LED Display Driver with Blanking Capability

SDA 2131-2

Bipolar IC

Features

- Integrated load resistances, thus few external components are required
- Number of LEDs software-selectable
- Blanking capability through DC-controlled input
- Simple connection to a microcomputer

Type	Ordering Code	Package
SDA 2131-2	Q67000-A2044	P-DIP-22

The SDA 2131-2 includes a static display driver for 16 LEDs, each featuring 10 mA output current. The serial data interface enables a simple connection to the microcomputer.

Circuit Description

A serial interface consisting of data input D, enable input E, and clock input CLK, connects the IC to a microprocessor. The 16-bit information ("H" at input D corresponds to the current flow at outputs A1 to A16) is loaded into a 16-bit shift register via the serial data input, beginning with LSB. Data transfer is initiated by the HL slope of the clock pulse at CLK. The data transfer D can take place only during the H state of the enable input E. A buffer accepts the data from the shift register during the HL slope of the enable input. The buffer directly drives the outputs A1 to A16.

The output is limited by an internal resistor of 290 Ω .

Through input C the outputs can be switched off ($V_{CS} = 0$ V).

The inputs D, E, and CLK, and the input C are TTL-compatible.

Block Diagram

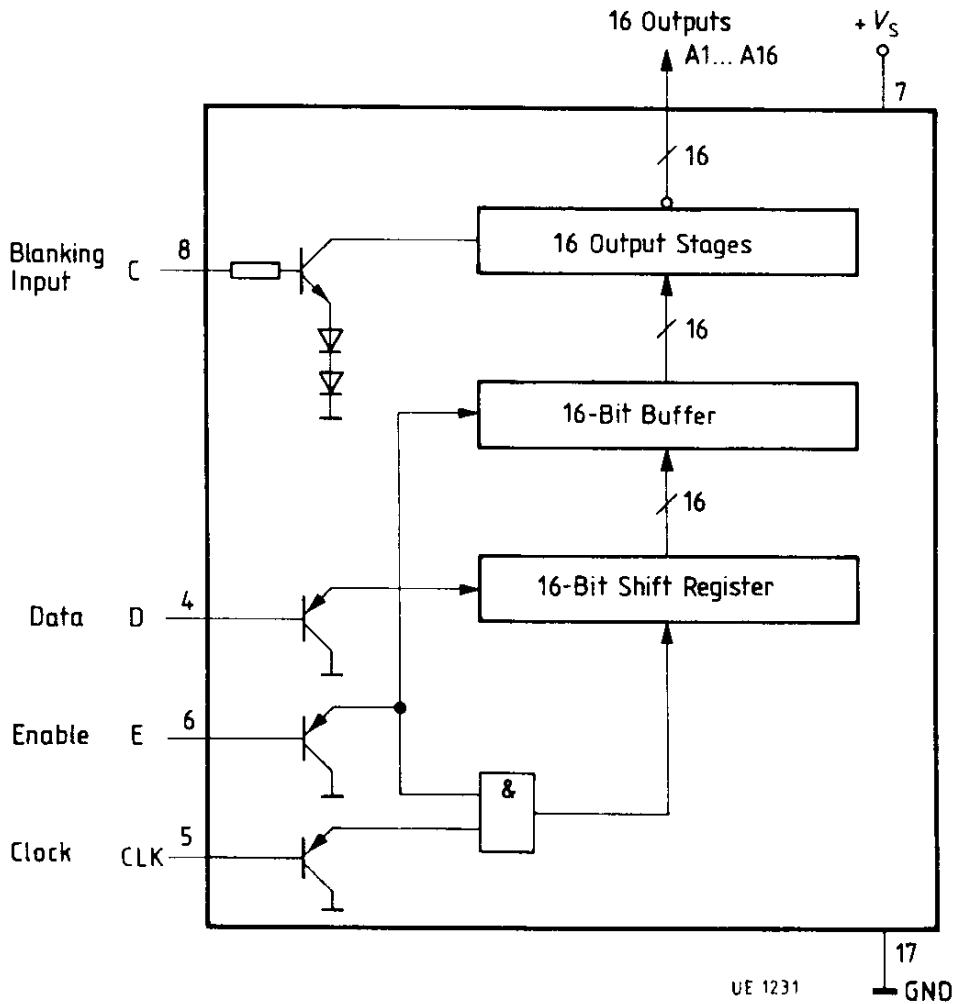

Internal Circuitry of an Output A:

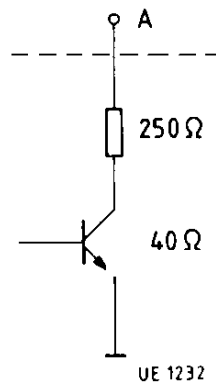

Pin Configuration (top view)

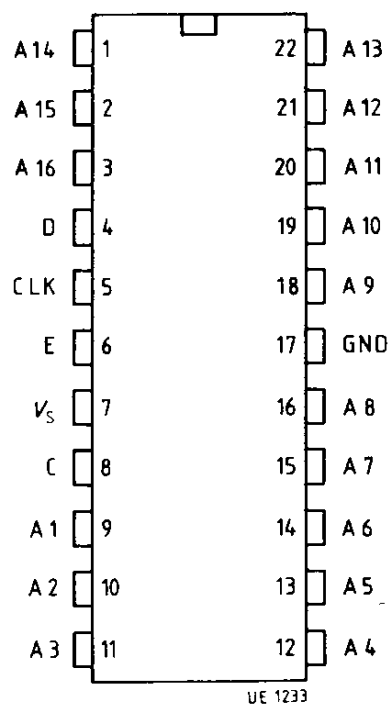

Pin Definitions and Functions

Pin No.	Symbol	Function
1	A14	Output 14 for LED cathode
2	A15	Output 15 for LED cathode
3	A16	Output 16 for LED cathode
4	D	Input for data
5	CLK	Input for clock
6	E	Input for enable
7	V_s	Supply voltage
8	C	Input for blanking
9	A1	Output 1 for LED cathode
10	A2	Output 2 for LED cathode
11	A3	Output 3 for LED cathode
12	A4	Output 4 for LED cathode
13	A5	Output 5 for LED cathode
14	A6	Output 6 for LED cathode
15	A7	Output 7 for LED cathode
16	A8	Output 8 for LED cathode
17	GND	Ground
18	A9	Output 9 for LED cathode
19	A10	Output 10 for LED cathode
20	A11	Output 11 for LED cathode
21	A12	Output 12 for LED cathode
22	A13	Output 13 for LED cathode

Maximum Ratings

Parameter	Symbol	Limit Values	Unit
Supply voltage range	V_{S7}	- 0.3 to 7	V
Input voltage range	$V_{i4,5,6}$	- 0.3 to 7	V
Output voltage range (outputs blocked) (pins 1 to 3, 9 to 16, 18 to 22)	V_{qH}	- 0.3 to 7	V
Input voltage C range	V_{C8}	- 0.3 to V_S	V
Junction temperature	T_J	150	°C
Storage temperature range	T_{stg}	- 40 to 125	°C
Thermal resistance (system-air)	$R_{th SA}$	65	K/W

The anode voltage of the LEDs and the number of simultaneously active outputs should be selected so that a total power dissipation of 800 mW in the IC is not exceeded.

Operating Range

Supply voltage	V_{S7}	4.5 to 5.5	V
Ambient temperature	T_A	0 to 70	°C

Characteristics $V_S = 5\text{ V}$; $T_A = 25\text{ °C}$

Parameter	Symbol	Limit Values			Unit
		min.	typ.	max.	
Supply current (all LEDs ON) $I_Q = 10\text{ mA}$	I_{S7}		10	15	mA
Quiescent current $I_Q = 0$; C = "L"	I_{S7}		2.5	3.5	mA
Switching voltage	$V_{S4,5,6}$	0.8	1.4	2.0	V
H - input current $V_H = 5.5\text{ V}$	$I_{H4,5,6}$			1	μA
L - input current $V_L = 0.4\text{ V}$	$-I_{L4,5,6}$			10	μA
Output current ($V_O = 2.9\text{ V}$) (pins 1 to 3, 9 to 16, 18 to 22)	I_Q	8	10	12.5	mA
Output leakage current ($V_O = V_S$) (pins 1 to 3, 9 to 16, 18 to 22)	I_{Q1}			10	μA
Switching voltage C	V_{S8}	1.5	2.1	2.7	V
H - input current C $V_{H8} = 5\text{ V}$	I_{H8}		0.6	0.9	mA
L - input current C $V_{L8} = 0\text{ V}$	$-I_{L8}$			1	μA
H - input current C (at switching voltage)	I_{H8}			15	μA

Switching Times

CLK (pin 5)	H pulse width	t_{HCLK}	1			μS
	L pulse width	t_{LCLK}	2			μS
	Set-up time	t_{SCLK}	0			μS
	Hold time	t_{hCLK}	0			μS
D (pin 4)	Set-up time	t_{SD}	0.5			μS
	Hold time	t_{HD}	0.5			μS
E (pin 6)	H pulse width	t_{HE}	50			μS
	L pulse width	t_{LE}	0.5			μS
	Set-up time	t_{SE}	1.5			μS
	Hold time	t_{HE}	1			μS
A	Delay time	t_A	10			μS

Application Circuit 1
2-digit 7-segment display

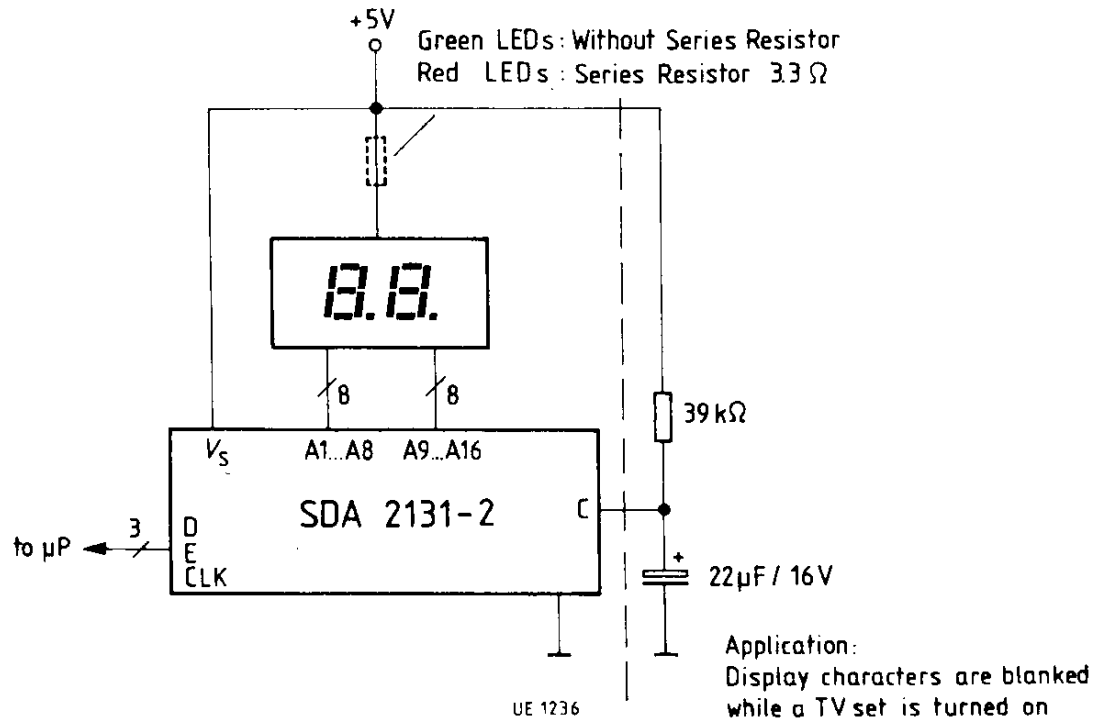

Application Circuit 2
Point display (1 of 16 diodes illuminated)

