

Multi-Plate Friction Clutches PD

Material: Steel.

Multi-plate friction clutches have proven to deliver an optimal performance when used with slow-starting machines. They are also used as safety couplings. The occurring torque peaks are levelled out by friction clutches. The disk pairing is steel/sintered bronze, with the inner plates of the pairings lined. The composition of the lining means up to 400°C can be withstood short term. At permanent load, however, only up to 250°C. Sintered clutch plates have the advantage of an almost constant friction coefficient even with fast growing circumferential speeds and higher temperatures. The assembly can be used for dry and wet operation. Advantages of these couplings are: Practical dimensions. Easy adjustment and re-adjustment. Inner and outer plates with special splines.

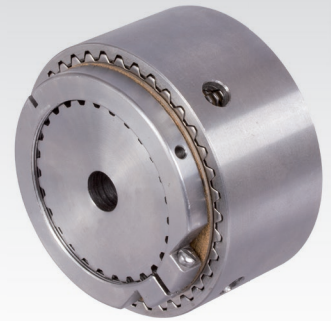
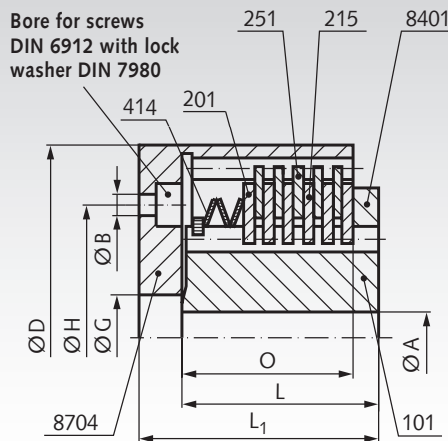

Couplings are available pre-drilled -0.2/-0.3 mm ex stock.
Customized bores and feather-key grooves available at extra charge

Product No.	Torque*		Bore. A		B mm	D mm	GH7 mm	H mm	L mm	L ₁ mm	O mm	Speed max. min ⁻¹	Weight kg	Product No. Spare Plates Compl. Set	Weight Spare Part g
	Dry Nm	Wet Nm	Pre-bore H7 mm	max. mm											
611 001 00	14	6	10	20 ¹⁾	3x for M5	55	22	34	28	36	22	3000	0,44	611 011 00	71
611 002 00	33	14	12	25 ²⁾	3x for M5	67	32	44	35	43	28	3000	0,81	611 012 00	140
611 003 00	62	26	12	40 ³⁾	4x for M6	82	45	58	40	48	30	3000	1,45	611 013 00	227
611 004 00	126	54	25	42	4x for M6	100	62	76	45	53	36	2500	2,24	611 014 00	339
611 005 00	230	100	25	55	4x for M8	120	72	90	55	65	42	2500	3,97	611 015 00	703
611 006 00	380	160	25	70	6x for M10	145	85	110	65	77	53	2500	5,82	611 016 00	1558

¹⁾ From Bore 17 mm only with flat feather key-grooves according to DIN 6885/3.

²⁾ From Bore 22 mm only with flat feather key-grooves according to DIN 6885/3.

³⁾ From Bore 38 mm only with flat feather key-grooves according to DIN 6885/3.

* Max. transmittable torque for dry or wet operation. The minimum adjustable torque is at about 50% of the maximum value.

Construction and Mounting

The hub 101 is equipped with splines, guiding the sinter-plates 215. The casing 8704 also has splines, which guide the outer plates 251 made from steel. The last component of the plate pack is the pressure plate 201. The disc springs 414 together with the adjusting screw 8401 lead to the friction grip of the plate pack. During assembly please make sure that the hub 101 and the casing are securely fixed in axial direction. When connecting 2 shaft ends, one shaft has to be mounted inside the housing 8704 supported by a centering bearing. The hub 101 must not rub against the casing 8704, but against

the sleeve or the inner bearing ring. At dry operating, make sure no oil or lubricate enters the plate pack. For re-adjustment loosen the locking screw in the adjusting nut 8401. Turning right will increase the torque, turning left leads to a reduction. After re-setting always re-tighten the locking screw. When ordering spare parts always state the factory number 8401 on the adjusting screw.

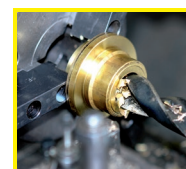

**Reworking within
24h-service possible.
Custom made parts
on request.**