

Order code	Manufacturer code	Description
30-3799	n/a	n/a

	Page 1 of 2
The enclosed information is believed to be correct, Information may change without notice due to product improvement. Users should ensure that the product is suitable for their use. E. & O. E.	Revision A 20/02/2007

### Top View of Assembly

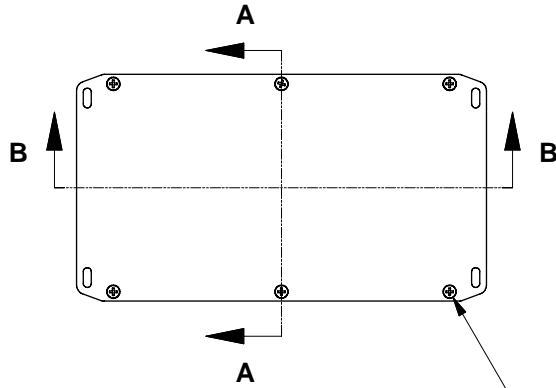

### SECTION A-A End View of Assembly

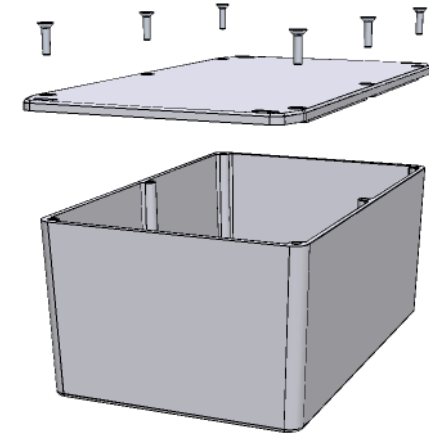
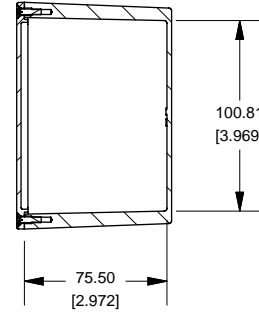

### SECTION B-B Side View of Assembly

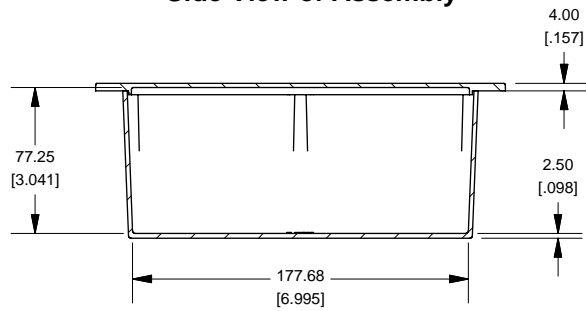

### Top View Looking Inside Box

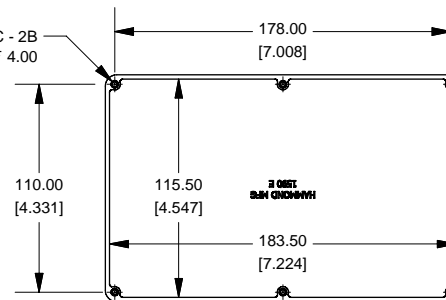

Enclosures can be Factory Modified ( Milling, Drilling, Printing etc.)  
 Contact Factory [mjm@hammondmfg.com](mailto:mjm@hammondmfg.com) for quotes  
 Solid models of this enclosure available in STEP or IGES.

#### NOTE

Purchased assembly includes box, lid and 6 cover screws.  
 Box and lid are made from Diecast Aluminum Alloy (alloy type 380).  
 Silicone Gasket Loctite #5950

#### PART NUMBERS

<b>1590EFL Enclosure</b>	
Unfinished	1590EFL
Grey Textured Polyester Powder Paint - RAL 7038	1590EFLGY
Black Textured Polyester Powder Paint - RAL 9011	1590EFLBK
<b>1590EFL Liquid Resistant Enclosure (Silicon Factory Installed Gasket)</b>	
Unfinished	1590WEFL
Black Textured Powder Paint	1590WEFLBK
<b>ACCESSORIES</b>	
Recommended Torque: 75 ozf.in / 55 cN.m	
Black Textured Cover Screws (Pkg 50) [6-32 x 1/2" SS Type 304]	1590WMS100BK
Unfinished Cover Screws (Pkg 100) [6-32 x 1/2" Nickel Plated Screws]	1590WMS100
<b>Standard Cover Screws</b>	
Unfinished Cover Screws (Pkg 100) [6-32 x 1/2" Nickel Plated Screws]	1590MS100
Black Textured Cover Screws (Pkg 50) [6-32 x 1/2" SS Type 304]	1590MS100BK

B

B

A

A



### SECTION C-C Side of Slot

