



Model Number

OMH-SLCT-02

Attachment aid for OMH-SLCT-01

Features

- Mounting bracket
- Simple and fast mounting

Dimensions

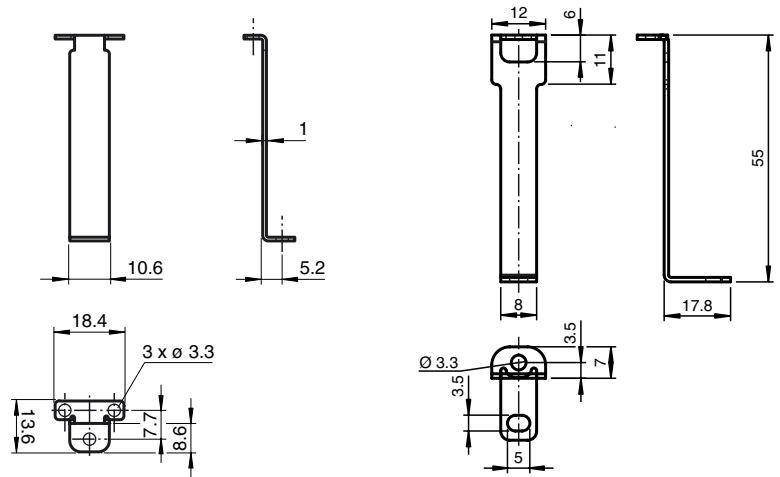

Technical data

Mechanical specifications

Material	Stainless steel
Mass	approx. 12 g
Mounting	Mounting accessories included

Suitable series

Safety Series	SLCT SLCS
---------------	--------------

Mounting note

Rear view and lateral mounting.

