



TAOGLAS®



Datasheet

FAKRA CODE D Violet Jack Connector

Part No:
FK.G3.SMBFST.D.AP

Description:

FAKRA Generation 3 – Code D Violet Jack for RG-174/RG-316 cables

Features:

FAKRA SMB Female Jack Connector

Frequency Range: DC - 6 GHz

Finish: Claret Violet

Dimensions: 30.04 x 13.8 x 11mm

RoHS & Reach Compliant

1. Introduction	3
2. Specifications	4
3. Mechanical Drawing	5
4. Packaging	6
<hr/>	
Changelog	7

Taoglas makes no warranties based on the accuracy or completeness of the contents of this document and reserves the right to make changes to specifications and product descriptions at any time without notice. Taoglas reserves all rights to this information contained herein.

Reproduction, use or disclosure to third parties without express permission is strictly prohibited.

Copyright © Taoglas Ltd.



1. Introduction



The FK.G3.SMBFST.A.AP connector was designed to be used on the RG-174 & RG-316 cables but can also be used on similar equivalent 2.9mm thick cables. This is a generation 3 type FAKRA connector so it has been designed with a swivel style housing for ease of installation. FAKRA connectors are used to denote the different cables used in a system, the colouring system allows the correct connection to be mated with the correct termination. The FAKRA connector is typically used on Automotive applications with this particular connector (FAKRA Code D) they are usually used in Cellular/LTE applications. All Taoglas connectors are RoHS & REACH compliant.

2. Specifications

Electrical	
Impedance	50Ω
Frequency	DC~3GHz
Dielectric Withstanding Voltage	800 VRMS, Min
VSWR	1.4(-15.6dB) Max. (DC-2GHz) 1.5(-13.9dB) Max. (2-3GHz)
Mechanical	
Durability	100 Cycles min
Dimensions	30.04 x 13.8 x 11mm
Casing	PPE + PS
Environmental	
Temperature Range	-40°C to 85°C

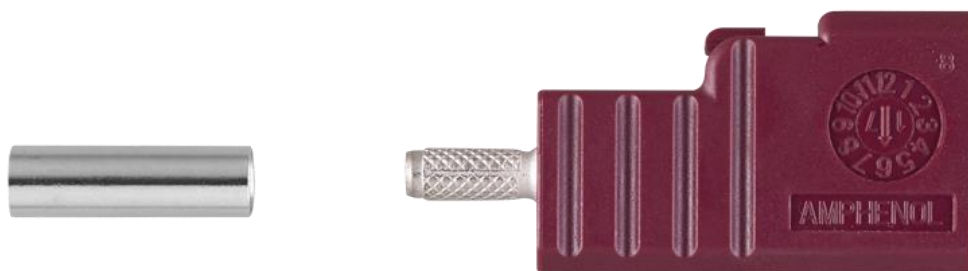

3. Mechanical Drawing (Units: mm)

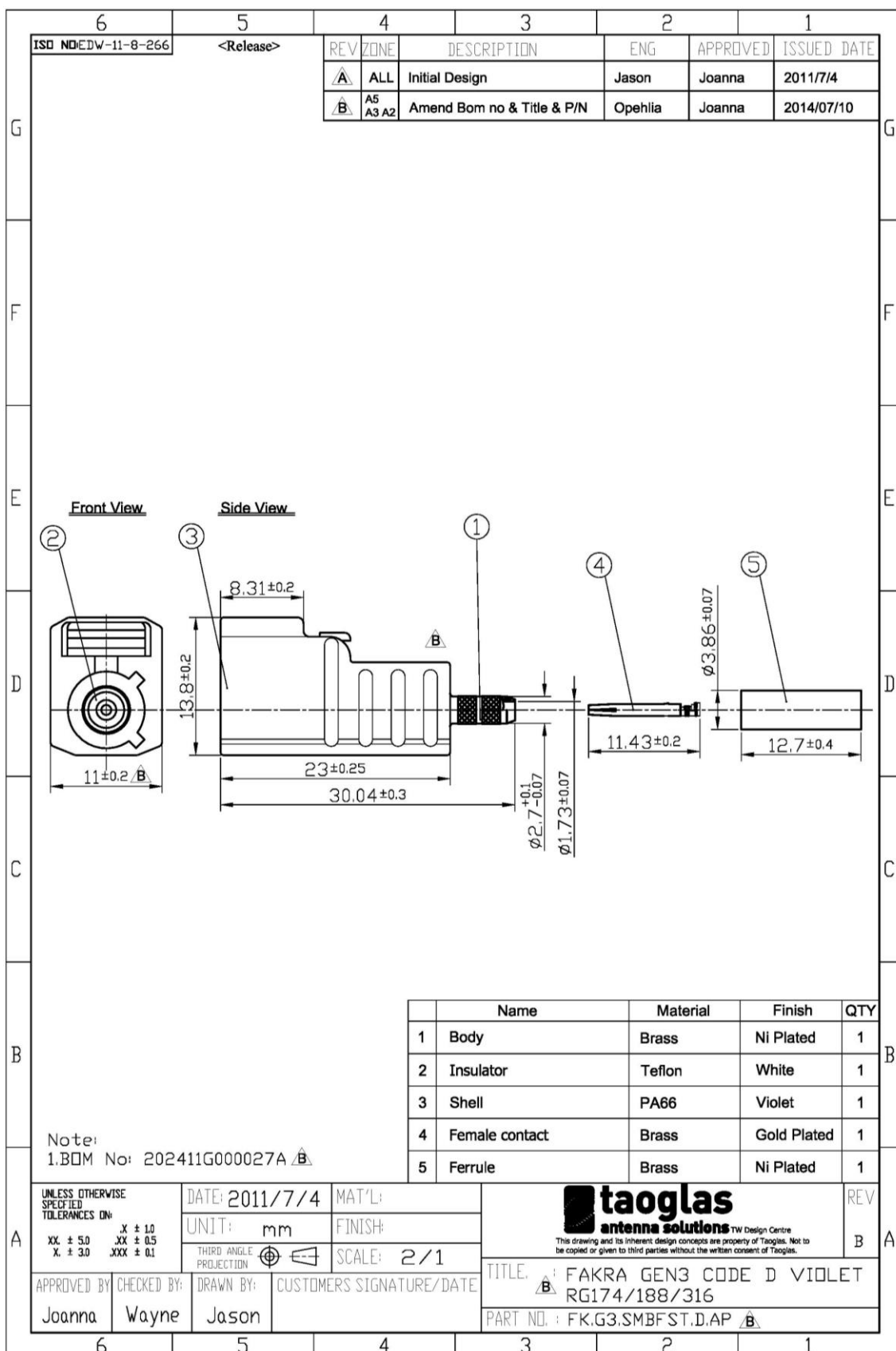

4. Packaging

50pcs FK.G3.SMBFST.D.AP Packaging per Tray
 Tray Dimensions: 300*180*20mm
 Weight – 190g

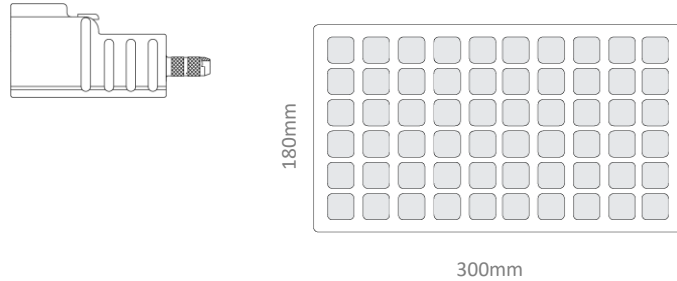

500pcs pin per PE Bag / 500pcs ferrule per PE Bag
 Dimensions: 3320*240*240 mm
 1 Set / 500 pcs ferrule & 500 pcs pin



500pcs connectors per carton
 1 set accessories per carton
 Dimensions: 327*280*218mm
 Carton Label
 Weight: 1.9Kg

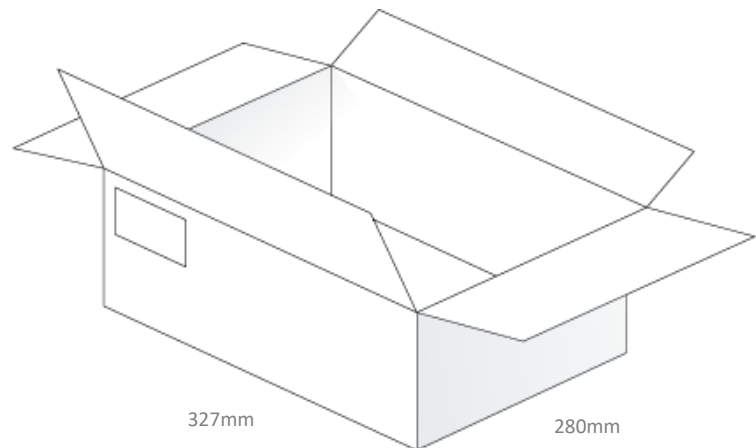

Changelog for the datasheet

DSP-19-8-042 – FK.G3.SMBFST.D.AP

Revision: A (Original First Release)

Date:	2019-05-08
Notes:	
Author:	Jack Conroy

Previous Revisions



TAOGLAS®

www.taoglas.com

