

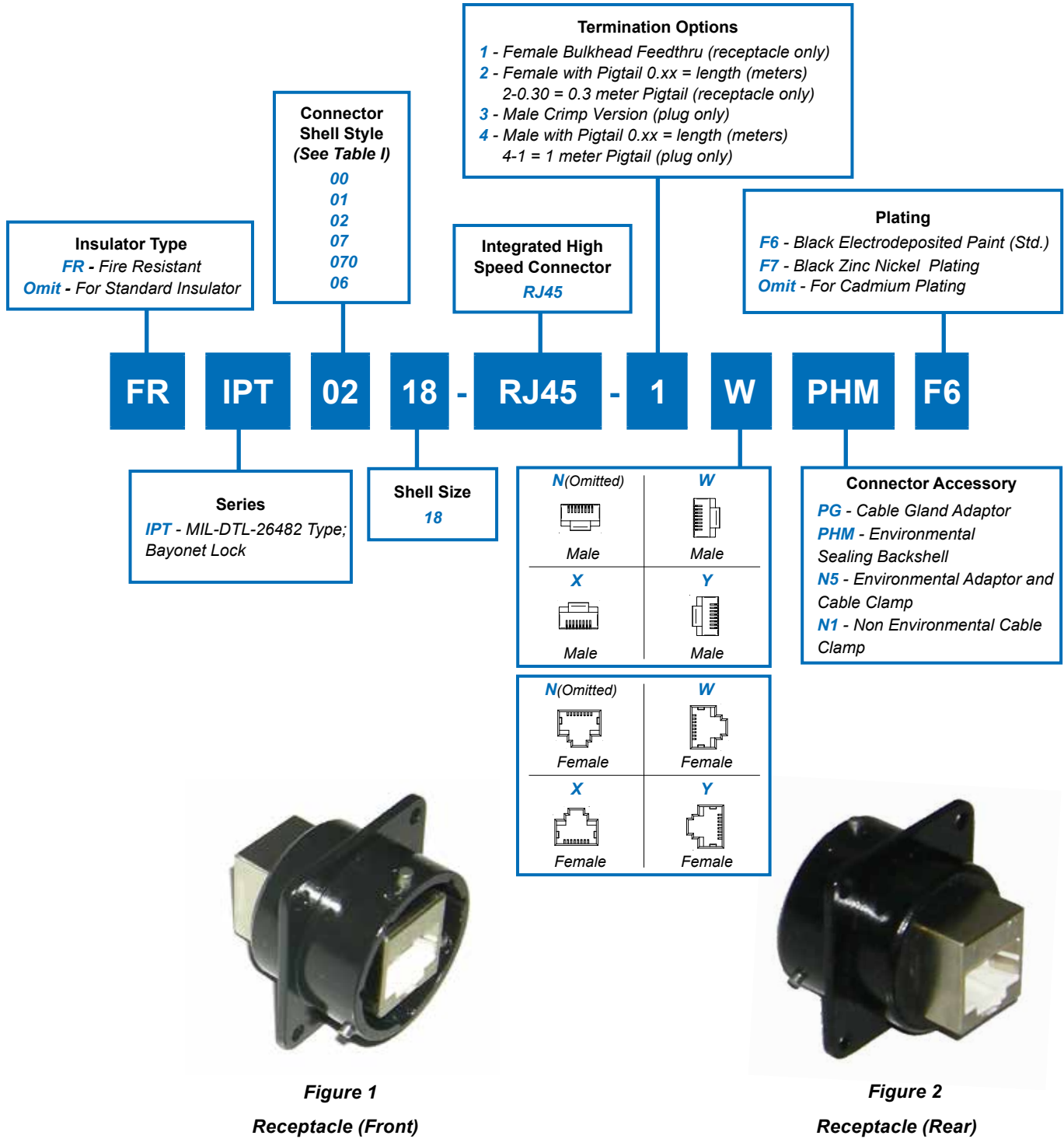

MIL-DTL-26482 Type Reverse Bayonet Coupling (Series IPT) with Single RJ45 Connector



MIL-DTL-26482 Type Reverse Bayonet Coupling (Series IPT) with Single RJ45 Connector



TABLE I

Connector Shell Detailed Description

00 - Front Panel Mount
Square Flange Receptacle
with Accessory Threads

01 - In Line Cylindrical
Receptacle with Accessory
Threads

02 - Front Panel Mount
Square Flange Receptacle;
No Accessory Threads

07 - Rear Panel Mount
Jam Nut Receptacle; No
Accessory Threads

070 - Rear Panel Mount
Jam Nut Receptacle with
Accessory Threads

06 - Straight Cylindrical
Plug Connector with
Accessory Threads

Commercial-grade RJ45 connectors are intended for use in clean, dry environments. Exposure to dirt and moisture can lead to damage or failure. Glenair's sealed RJ45 connectors provide a high level of protection for the most hostile environments. Standard RJ45 jacks are housed in rugged, waterproof IPT Series bayonet connectors. Connectors feature resilient nitrile inserts and electrodeposited corrosion-resistant black paint or black zinc nickel plating. Cadmium plating is also available. A typical IPT RJ45 application consists of a through bulkhead female receptacle (*Figure 1 and 2*) and a male plug crimp RJ45 (*Figure 3*).

TECHNICAL CHARACTERISTICS

Category	Cat. 6 (Cat 5E available upon request)
Connection	10BaseT, 100BaseTx, 1000BaseT
Working Voltage	30/42 Volts AC RMS/VDC
Max Current Rating	1.5 Amps at 20° C
Max Contact Resistance	20 mΩ
Min. Insulation Resistance	1.000 mΩ at 500 Volts DC
Dielectric Withstanding Voltage	1000 Volts
Working Temperature	-40° to +68° C
Environmental Rating	IP67 (mated)



Figure 3
Plug (Front)



Figure 4
RJ45 Interconnection Sequence



MIL-DTL-26482 Type Reverse Bayonet Coupling (Series IPT) with Single RJ45 Connector

CONFIGURATIONS AVAILABLE : IPT 00

Front View

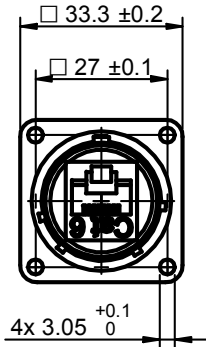

FRIPT0018-RJ45-1PGF6

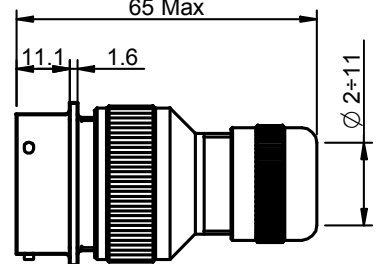
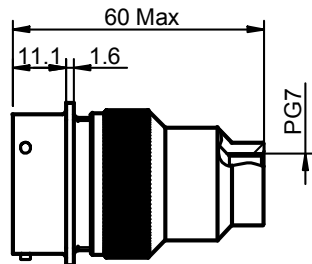

FRIPT0018-RJ45-1PHMF6

Front View

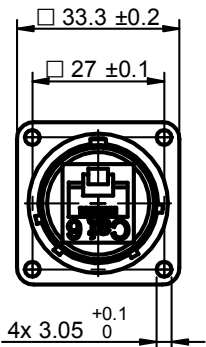

FRIPT0018-RJ45-1N5F6

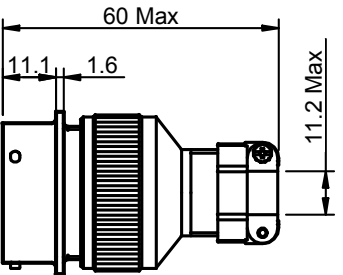
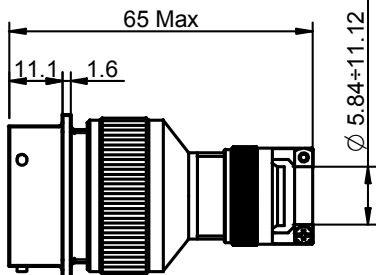

FRIPT0018-RJ45-1N1F6

CONFIGURATIONS AVAILABLE : IPT 01

Front View

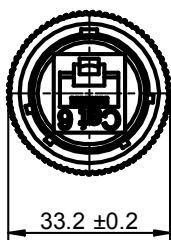

FRIPT0118-RJ45-1PGF6

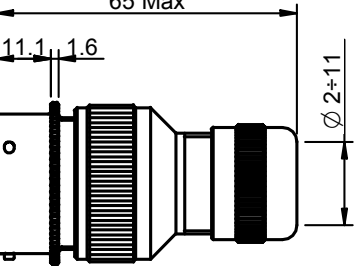
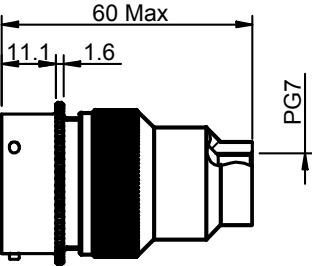

FRIPT0118-RJ45-1PHMF6

MIL-DTL-26482 Type Reverse Bayonet Coupling
(Series IPT)
with Single RJ45 Connector



High-Speed
Connectors

CONFIGURATIONS AVAILABLE : IPT 01

Front View

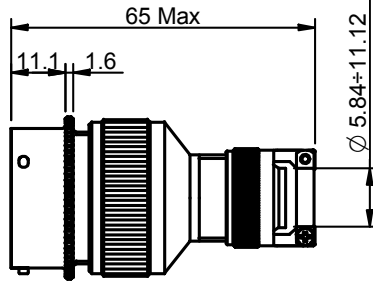
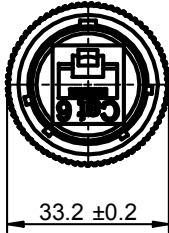

FRIPT0118-RJ45-1N5F6

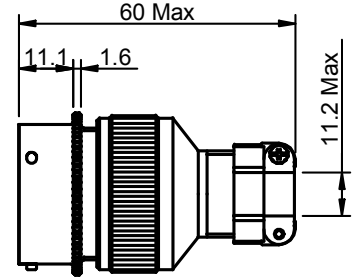

FRIPT0118-RJ45-1N1F6

CONFIGURATIONS AVAILABLE : IPT 070

Front View

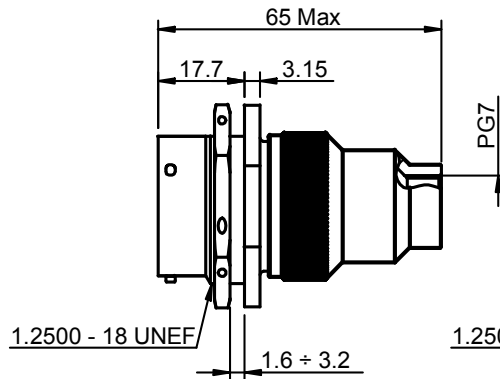
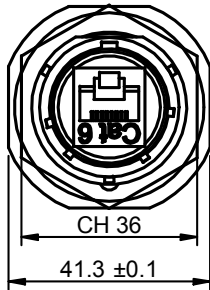

FRIPT07018-RJ45-1PGF6

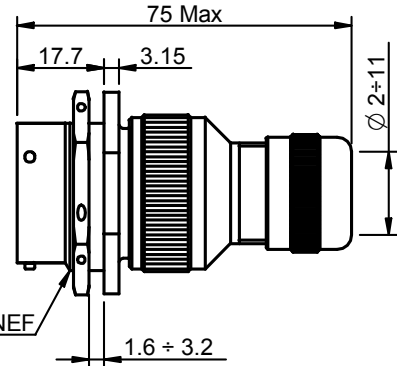

FRIPT07018-RJ45-1PHMF6

Front View

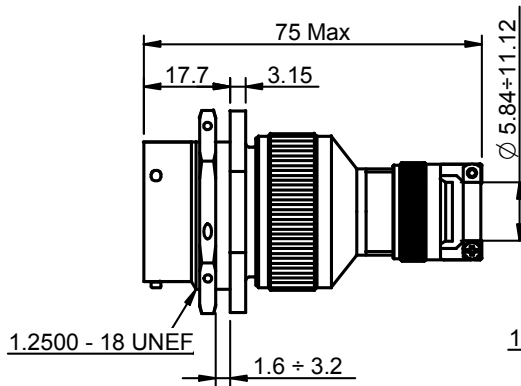
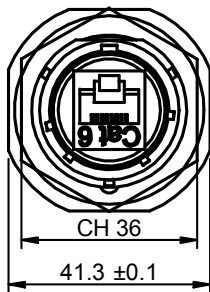

FRIPT07018-RJ45-1N5F6

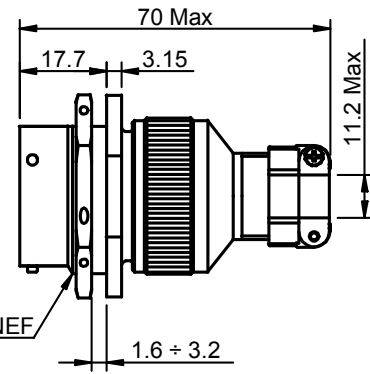

FRIPT07018-RJ45-1N1F6

Connectors



MIL-DTL-26482 Type Reverse Bayonet Coupling (Series IPT) with Single RJ45 Connector

CONFIGURATIONS AVAILABLE : IPT 06

Front View

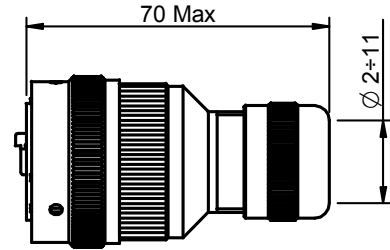
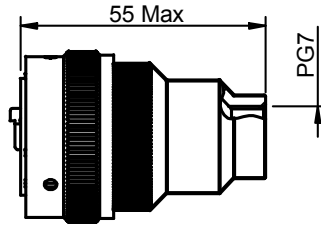
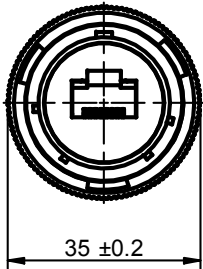

FRIPT0618-RJ45-3PGF6

FRIPT0618-RJ45-3PHMF6

Front View

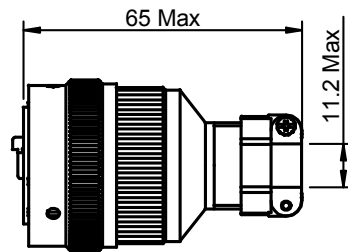
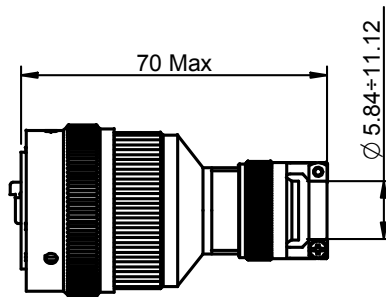
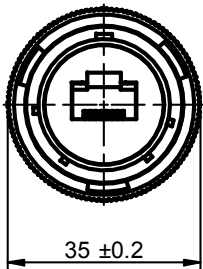

FRIPT0618-RJ45-3N5F6

FRIPT0618-RJ45-3N1F6

CONFIGURATIONS AVAILABLE : IPT 02 and IPT 07

02

Front View

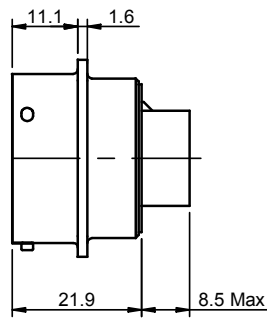
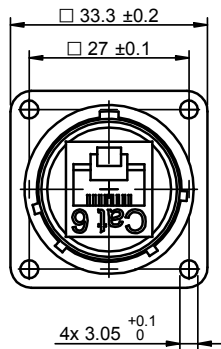

FRIPT0218-RJ45-1F6

Front View

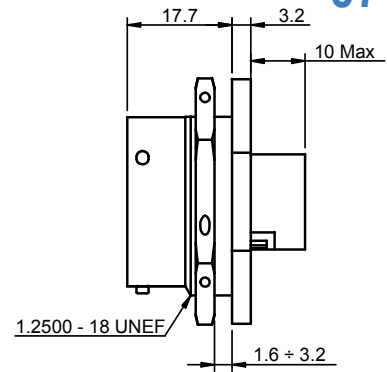
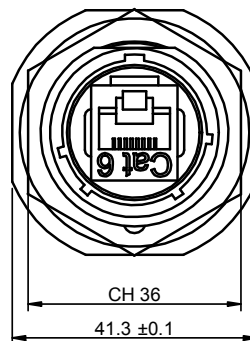

FRIPT0718-RJ45-1F6

07

MIL-DTL-26482 Type Reverse Bayonet Coupling
(Series IPT)
with Single RJ45 Connector



PIGTAIL GENERAL SKETCHES AND CONFIGURATIONS AVAILABLE

Female with Pigtail for Configuration : 00 - 01 - 030 - 070

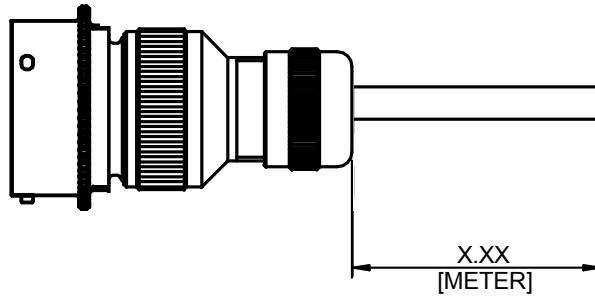

EXAMPLE : FRIPT0018-RJ45-21.5PHMF6 → 1.5 mt Pigtail

Female with Pigtail for Configuration : 00
FRIPT0018-RJ45-2X.xxN1F6
FRIPT0018-RJ45-2X.xxN5F6
FRIPT0018-RJ45- 2X.xxPHMF6
FRIPT0018-RJ45-2X.xxPGF6

Female with Pigtail for Configuration : 030
FRIPT03018-RJ45-2X.xxN1F6
FRIPT03018-RJ45-2X.xxN5F6
FRIPT3018-RJ45-2X.xxPHMF6
FRIPT03018-RJ45-2X.xxPGF6

Female with Pigtail for Configuration : 01
FRIPT0118-RJ45-2X.xxN1F6
FRIPT0118-RJ45-2X.xxN5F6
FRIPT0118-RJ45-2X.xxPHMF6
FRIPT0118-RJ45-2X.xxPGF6

Female with Pigtail for Configuration : 070
FRIPT07018-RJ45-2X.xxN1F6
FRIPT07018-RJ45-2X.xxN5F6
FRIPT07018-RJ45-2X.xxPHMF6
FRIPT07018-RJ45-2X.xxPGF6

Male with Pigtail for Configuration : 06

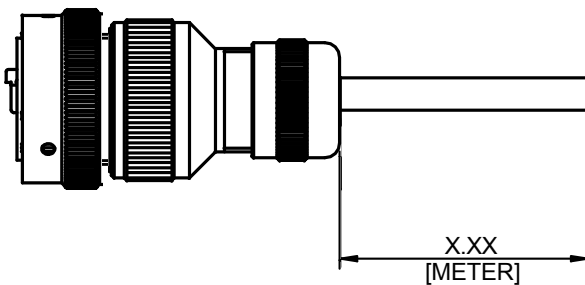

Female with Pigtail for Configuration : 06
FRIPT0618-RJ45-4X.xxN1F6
FRIPT0618-RJ45-4X.xxN5F6
FRIPT0618-RJ45-4X.xxPHMF6
FRIPT0618-RJ45-4X.xxPGF6

EXAMPLE : FRIPT0618-RJ45-41.5PHMF6 → 1.5 mt Pigtail