

REV	ECN	DESCRIPTION	DATE	MODIFIED
A	C2255	RELEASE		
B	C2438	UPDATE DRAWING	Aug-16-17	Rock

Amphenol PCD SZ
ORIGINAL
PDF Format
02 Dec. 13R&D

PART NUMBERING SCHEME

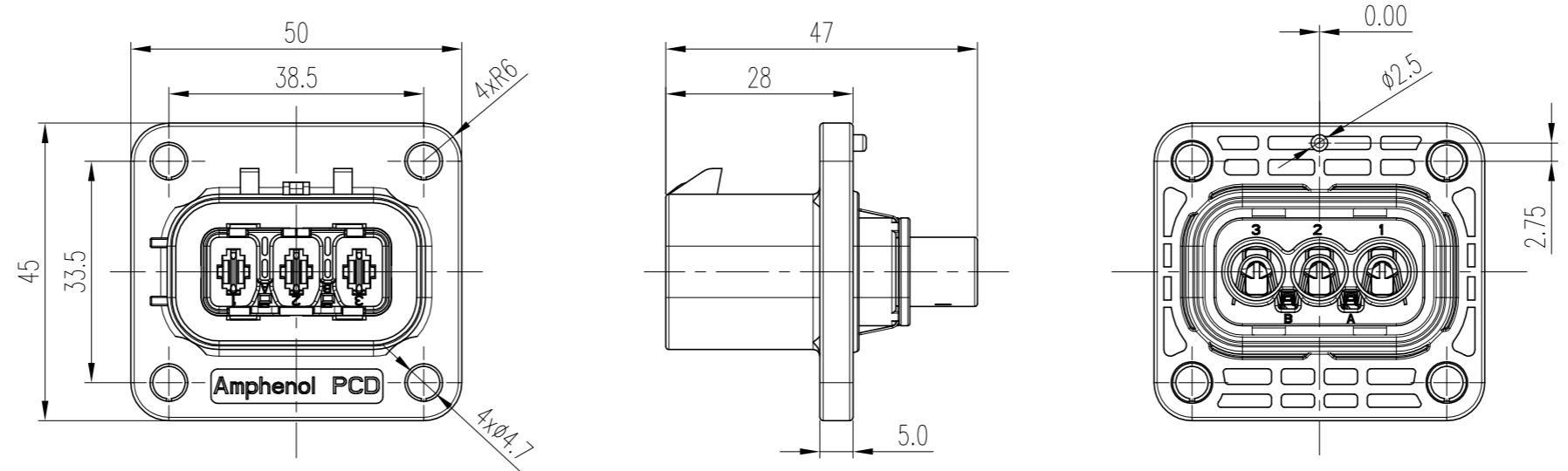
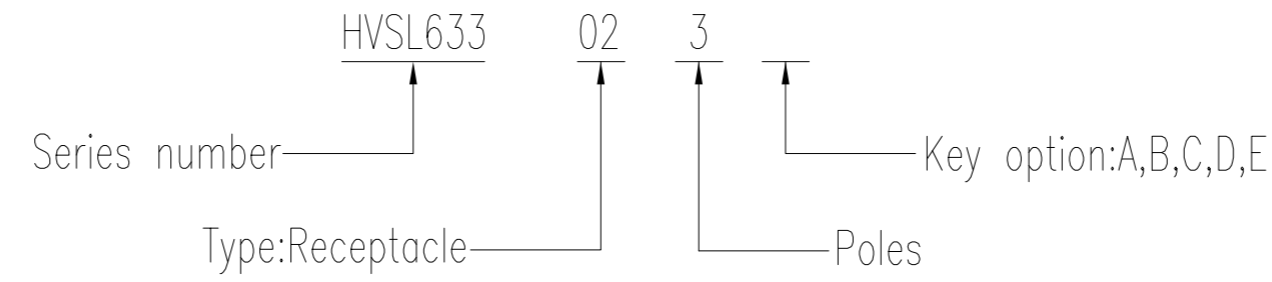

*TECHNICAL PARAMETERS

Material
Housing : PA66 UL94-V0
Contacts: Copper alloy, Tin plated
Shield: Copper alloy
Seal: Silicone

Mechanical data
Operating Temperature: -40°C~+125°C
Durability: 50 cycles
Contact Type: Crimping
IP67, IP2XB

Electrical data
Withstand Voltage: 3000V AC r.m.s
Rated Current : 32A(4mm² cable)
40A(6mm² cable)
Rated Voltage: 800V AC
Insulation Resistance: >200MΩ
Contact Resistance: < 2mΩ
Suited to fit 4~6mm² cable
Shielded

*NOTES:

1. Power contact and HVIL contact should be ordered separately. detail see ordering information table
2. HVSL633023A shown in this sheet

Ordering information table

Assembly items	Separately ordering parts/需单独购买的零件	
HVSL633023X (X=A,B,C,D,E)	Power contact (QTY per assembly)	HVIL contact (QTY per assembly)
	C310003622 (3pcs)	C310003614 (2pcs)

DIMENSIONS	TOLERANCES	PROJECTION	TITLE		
ANSI Y14.5M UNITS: MM CAD FILE	.X ± 0.2 .XX ± 0.10 ANGLES ± 2'		Amphenol Pcd Shenzhen		
ORIGINAL	THIS DOCUMENT CONTAINS PROPRIETARY INFORMATION WHICH IS THE CONFIDENTIAL PROPERTY OF AMPHENOL PCD SHENZHEN		ENGR R.Chen 2017.02.08		
			CHKD		
			APPD		
		SIZE A3	DWG NO. C-HVSL633023X	REV B	
		CODE:	SCALE 1:1	SHEET 1 OF 3	

C-HVSL633023X

C-HVSL633023X

C-HVSL633023X

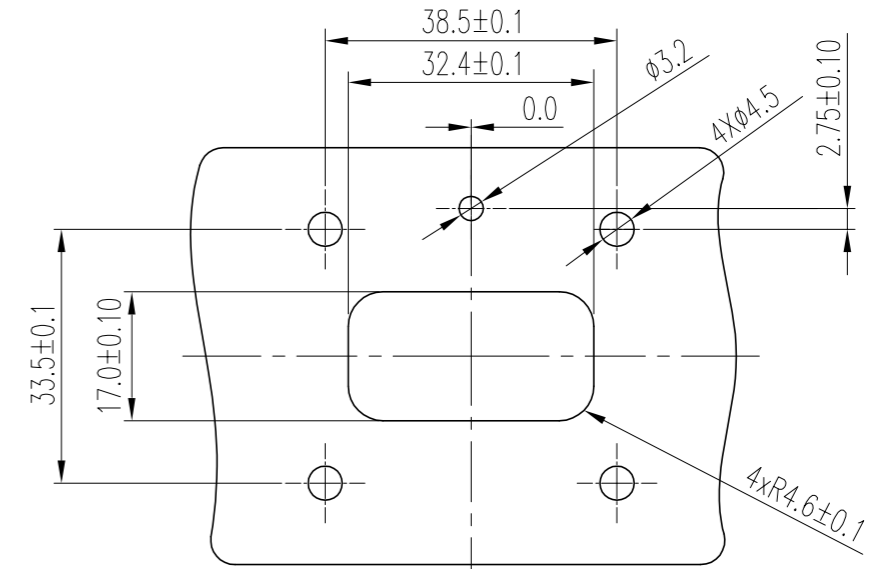
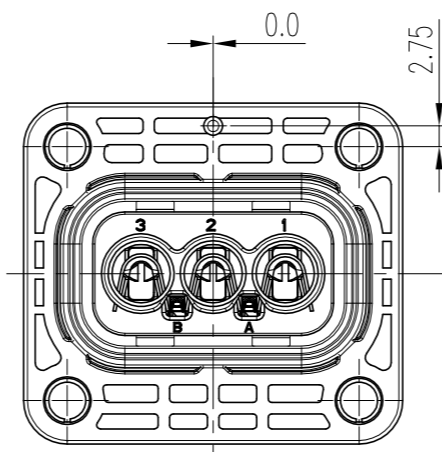
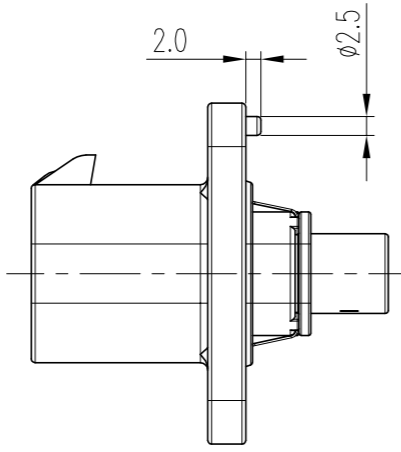
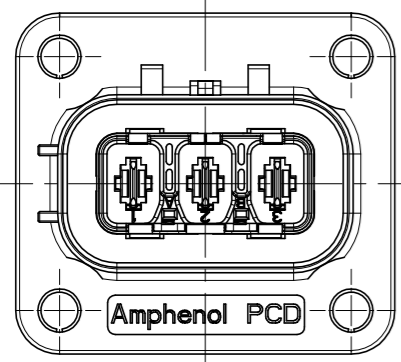

KEY A
HVSL633023A

MOUNTING INTERFACE REFERENCE

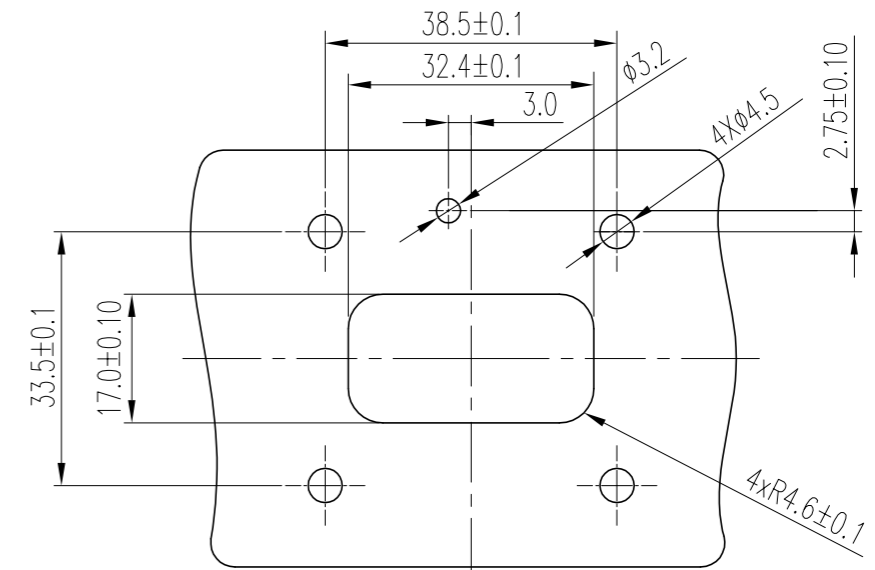
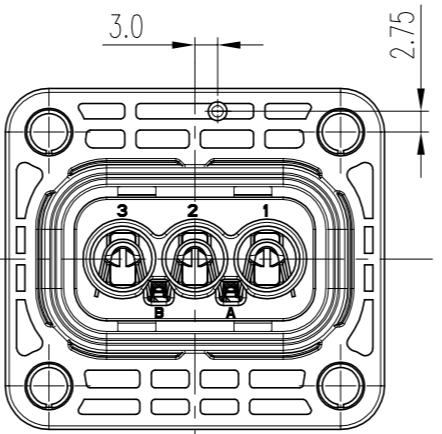
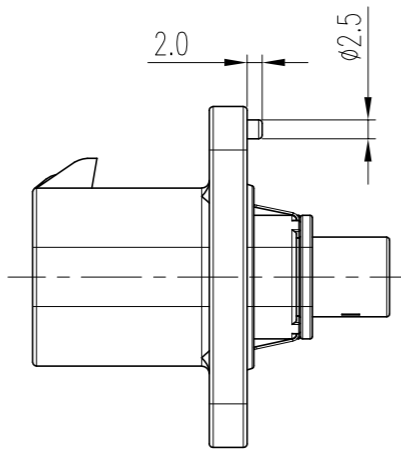
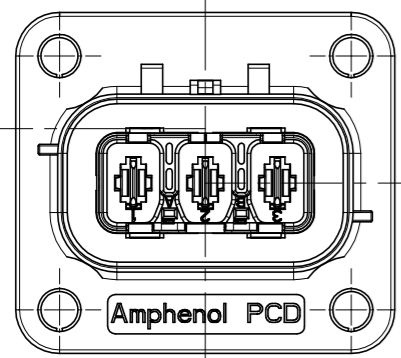

KEY B
HVSL633023B

MOUNTING INTERFACE REFERENCE

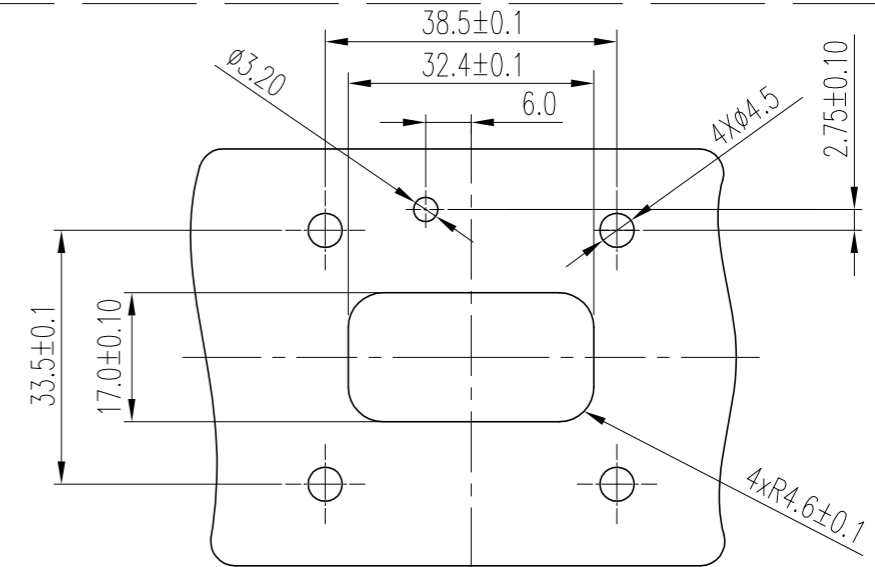
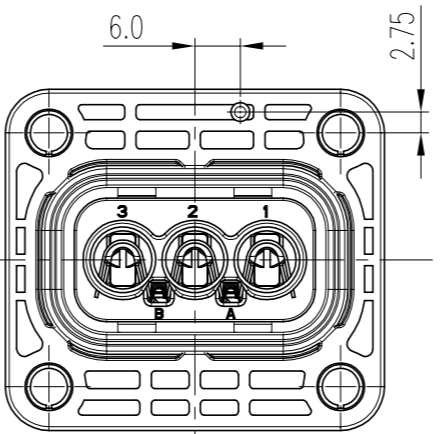
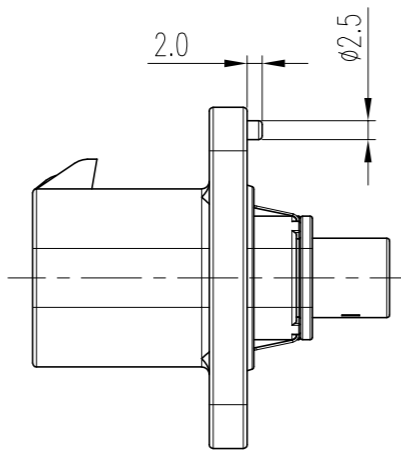
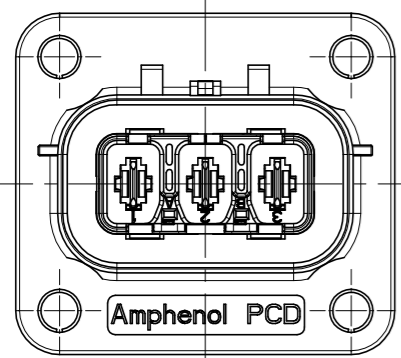

KEY C
HVSL633023C

MOUNTING INTERFACE REFERENCE

C-HVSL633023X

C-HVSL633023X

SIZE A3	DWG NO. C-HVSL633023X	REV B
CODE:	SCALE 1:1	SHEET 2 OF 3

C-HVSL633023X

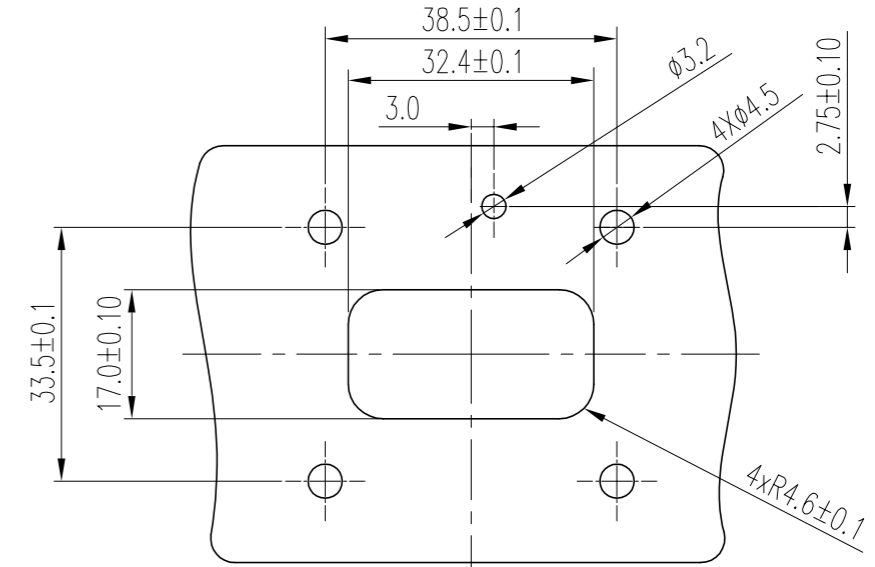
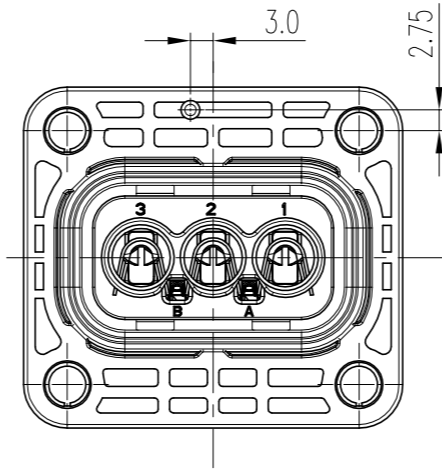
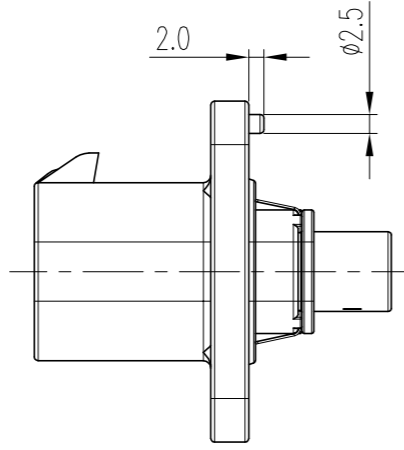
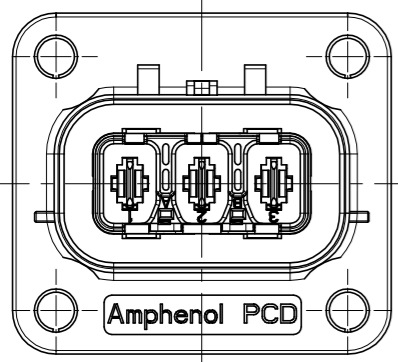

KEY D
HVSL633023D

MOUNTING INTERFACE REFERENCE

C-HVSL633023X

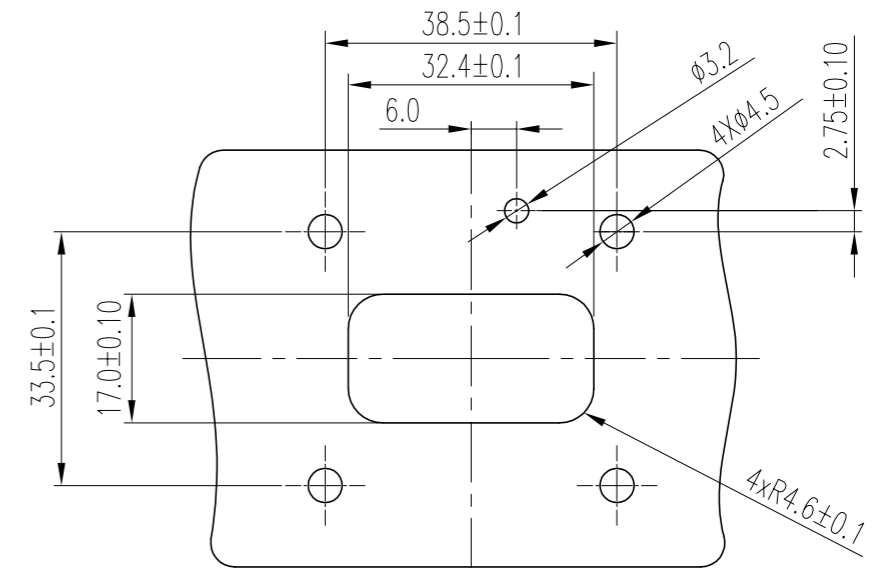
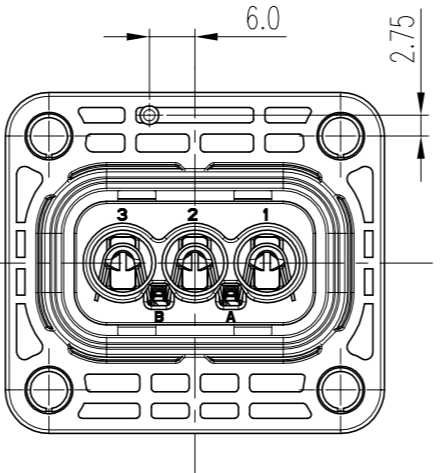
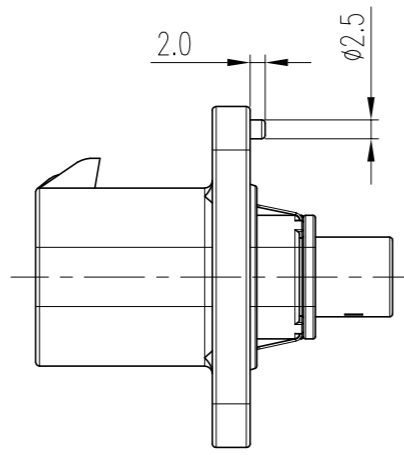
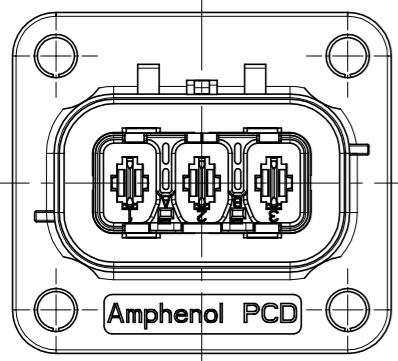

KEY E
HVSL633023E

MOUNTING INTERFACE REFERENCE

C-HVSL633023X

SIZE A3	DWG NO. C-HVSL633023X	REV B
CODE:	SCALE 1:1	SHEET 3 OF 3