

Panasonic
ideas for life

**Compact high capacity
(25A max)
Slim heat sink combined type
joining the lineup**

AQ-J RELAYS

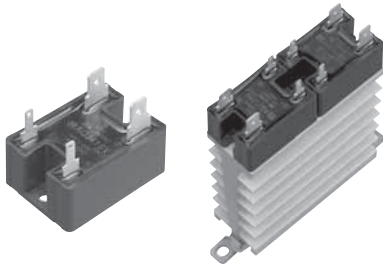

Slim heat sink combined type

FEATURES

- 1. Compact Size**
Approx 40% reduction in required space achieved in the footprint area compared with the previous model (AQ-R relay)
- 2. Built-in varistor**
- 3. Reverse input connection prevention function**
- 4. Labor Saving (tab terminal)**
- 5. Output arrangement 1a and 1a × 2 available in the heat sink combined type**

TYPICAL APPLICATIONS

- 1. Kitchen appliances**
- 2. Vending machine**
- 3. Injection molding machine**
- 4. Packing machine**
- 5. Amusement machine**

Note: * International standards are acquired for AQ-J SSR stand-alone, not applied to heat sink combined type.

ORDERING INFORMATION

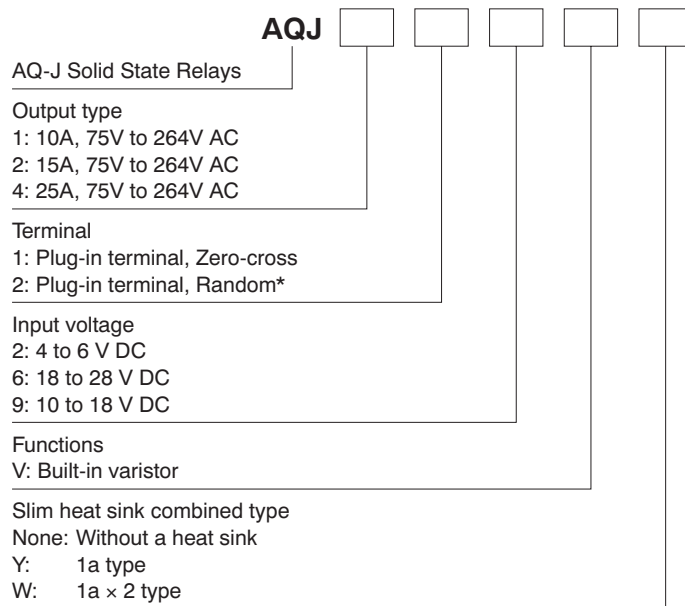

Note: * Random type is available by custom order.

TYPES

1. AQ-J Solid State Relays

Type	Load current	Load voltage	Input voltage	Part No.
Zero-cross*	10A	75V to 264V AC	4 to 6V DC	AQJ112V
			10 to 18V DC	AQJ119V
			18 to 28V DC	AQJ116V
	15A		4 to 6V DC	AQJ212V
			10 to 18V DC	AQJ219V
			18 to 28V DC	AQJ216V
	25A		4 to 6V DC	AQJ412V
			10 to 18V DC	AQJ419V
			18 to 28V DC	AQJ416V

Standard Packing; carton: 10 pcs., case: 200 pcs.
Note: * Random type also available. Please inquire.

AQ-J

2. AQ-J SSR Slim Heat Sink Combined Type

Output configuration	Type	Load current	Load voltage	Input voltage	Part No.
1a	Zero-cross*	10A	75V to 264V AC	4 to 6V DC	AQJ112VY
				10 to 18V DC	AQJ119VY
				18 to 28V DC	AQJ116VY
1a × 2		10A (per 1a)		4 to 6V DC	AQJ412VY
				10 to 18V DC	AQJ419VY
				18 to 28V DC	AQJ416VY
1a × 2	15A (per 1a)	15A (per 1a)	4 to 6V DC	AQJ112VW	
			10 to 18V DC	AQJ119VW	
			18 to 28V DC	AQJ116VW	
				4 to 6V DC	AQJ412VW
				10 to 18V DC	AQJ419VW
				18 to 28V DC	AQJ416VW

Standard Packing; no carton, case: 10 pcs.

Note: * Random type also available. Please inquire.

3. Accessories

Type	Part No.	Packaged quantity
DIN rail mounting plate	AQP-DPJ	5 in a carton, 50 in a case
Slim heat sink (28mm wide) (Mountable on a DIN rail)	AQP-HS-SJ10A	No carton, 10 in a case
Slim heat sink (45mm wide) (Mountable on a DIN rail)	AQP-HS-SJ20A	No carton, 8 in a case
Standard heat sink (10A and 15A)	AQP-HS-J10A	5 in a carton, 20 in a case
Standard heat sink (25A only)	AQP-HS-J25A	No carton, 5 in a case

SPECIFICATIONS

1. Ratings (Test sample: AQ-J stand-alone, Measurement condition: at 20°C 68°F, input ripple: 1% or less)

1) Input side

Item	Part No.	AQJ112V AQJ212V AQJ412V	AQJ119V AQJ219V AQJ419V	AQJ116V AQJ216V AQJ416V
Rated voltage		5V DC	12V DC	24V DC
Input voltage		4 to 6V DC	10 to 18V DC	18 to 28V DC
Input impedance		Approx. 260Ω	Approx. 800Ω	Approx. 1.6kΩ
Drop-out voltage		Min. 1V DC		

2) Output side

Item	Part No.	AQJ112V AQJ119V AQJ116V	AQJ212V AQJ219V AQJ216V	AQJ412V AQJ419V AQJ416V
Max. load current		10A	15A	25A
Load voltage		75 to 264V AC		
Frequency		45Hz to 65Hz		
Non-repetitive surge current		100A	150A	250A
Max. "OFF-state" leakage current		Max. 5mA		
Max. "ON-state" voltage drop		Max. 1.6V		
Min. load current*		50mA		

Note: * When the load current is less than the rated minimum load current, please refer to [Cautions for Use](#)

2. Ratings (Test sample: AQ-J slim heat sink combined type, Measurement condition: at 20°C 68°F, input ripple: 1% or less)

1) Input side

Item	Part No.	AQJ112V(Y-W) AQJ412V(Y-W)	AQJ119V(Y-W) AQJ419V(Y-W)	AQJ116V(Y-W) AQJ416V(Y-W)
Rated voltage		5V DC	12V DC	24V DC
Input voltage		4 to 6V DC	10 to 18V DC	18 to 28V DC
Input impedance		Approx. 260Ω	Approx. 800Ω	Approx. 1.6kΩ
Drop-out voltage		Min. 1V DC		

2) Output side

Item	Part No.	AQJ112VY AQJ119VY AQJ116VY	AQJ412VY AQJ419VY AQJ416VY	AQJ112VW AQJ119VW AQJ116VW	AQJ412VW AQJ419VW AQJ416VW
Output arrangement		1a		1a × 2	
Max. load current*1		10A	20A	10A	15A
Load voltage		75 to 264V AC			
Frequency		45Hz to 65Hz			
Non-repetitive surge current		100A	250A	100A	250A
Max. "OFF-state" leakage current		Max. 5mA			
Max. "ON-state" voltage drop		Max. 1.6V			
Min. load current*2		50mA			

Notes: *1 Please refer to REFERENCE DATA, "1. Load current vs. ambient temperature" below.

*2 When the load current is less than the rated minimum load current, please refer to [Cautions for Use](#)

3. Characteristics (Measurement condition: at 20°C 68°F, input ripple: 1% or less)

Item	Characteristics	Remarks
Operate time, max.	(1/2 cycle of voltage sine wave) + 1ms	
Release time, max.	(1/2 cycle of voltage sine wave) + 1ms	
Insulation resistance, min.	100MΩ between input to output to case	Using 500 V DC megger
Breakdown voltage	3,000 Vrms between input and output	for 1min.
	2,500 Vrms between input, output and case	
Vibration resistance	SSR stand-alone: 10 to 55Hz, double amplitude of 1.5mm Slim heat sink combined type: 10 to 55Hz, double amplitude of 0.75mm	X, Y, Z axes
Shock resistance	SSR stand-alone: Min. 980m/s ² Slim heat sink combined type: Min. 197m/s ²	X, Y, Z axes
Ambient temperature	-30 to +80°C -22 to +176°F	Non-condensing at low temperatures
Storage temperature	-30 to +100°C -22 to +212°F	
Operational method	Zero-cross (Turn ON and Turn OFF)	

REFERENCE DATA

(1) AQ-J Solid State Relays

1. Load current vs. ambient temperature Use load current within range specified in the figure below

Tested condition:

- 1) If attached to a heat sink, use a heat conductive compound (Ex. Toshiba silicone YG6111 or TSK5303) of similar coating to improve cooling
- 2) Without external heat sink
If the mounting surface is not metallic and a heat sink is not used, expose the bottom surface and plate surface to improve heat dissipation.
- 3) The current value is per 1a.

(1) 10 A type (when using heat sink or iron plate)

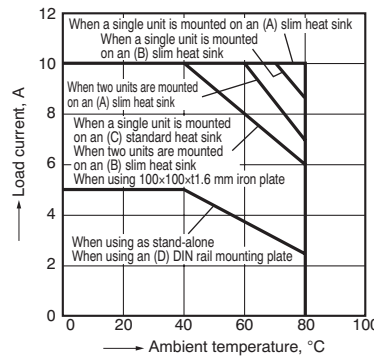

(2)-1. 15 A type (when using iron plate)

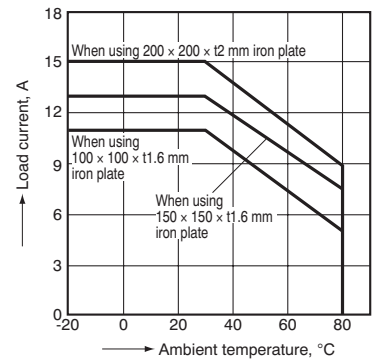

(2)-2. 15 A type (when using a heat sink)

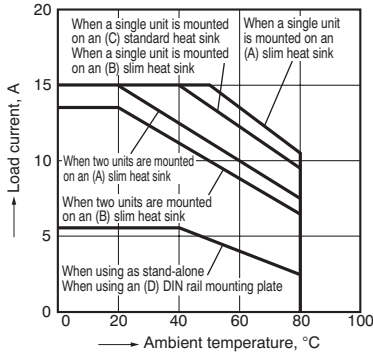

(3)-1. 25 A type (when using iron plate)

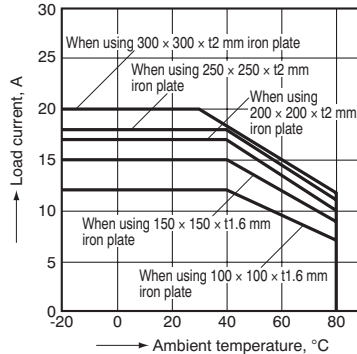

(3)-2. 25 A type (when using a heat sink)

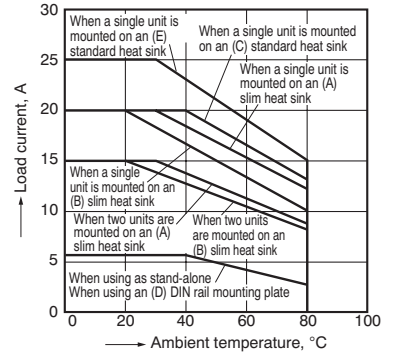

2. Non-repetitive surge current vs. carrying time

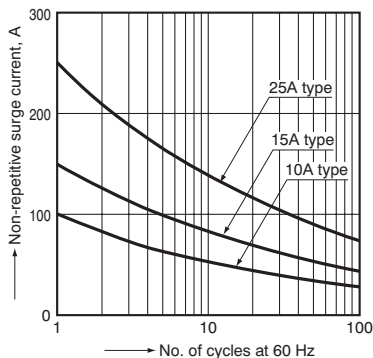

3. Input current vs. input voltage characteristics

(10A, 15A and 25A common)

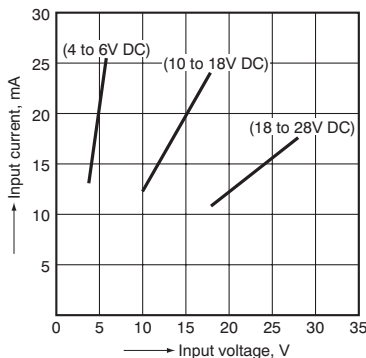

(A) slim heat sink	AQP-HS-SJ20A
(B) slim heat sink	AQP-HS-SJ10A
(C) standard heat sink	AQP-HS-J10A
(D) DIN rail mounting plate	AQP-DPJ
(E) standard heat sink	AQP-HS-J25A

AQ-J

(2) AQ-J SSR Slim Heat Sink Combined Type

1. Load current vs. ambient temperature Use load current within range specified in the figure below

(1) Output arrangement: 1a

(2) Output arrangement: 1a × 2

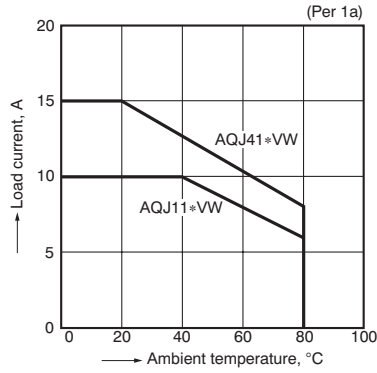
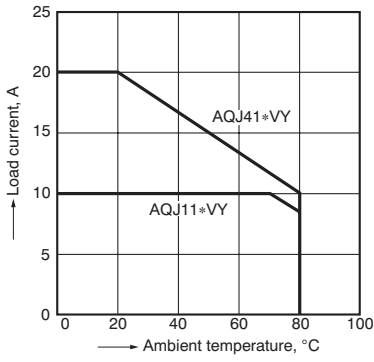

Note:
When two contacts are operated simultaneously.
In the case of a single-contact operation, the rating of
(1) AQJ11*VY, AQJ41*VY applies.

2. Surge current vs. carrying time

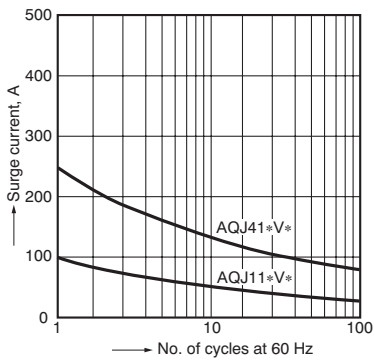

3. Input current vs. input voltage characteristics

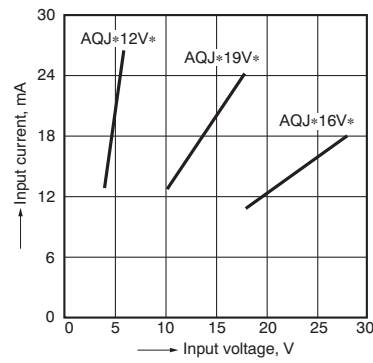

DIMENSIONS (mm inch)

Download [CAD Data](#) from our Web site.

1. AQ-J Stand Alone

[CAD Data](#)

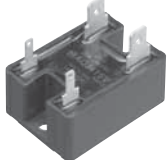

External dimensions

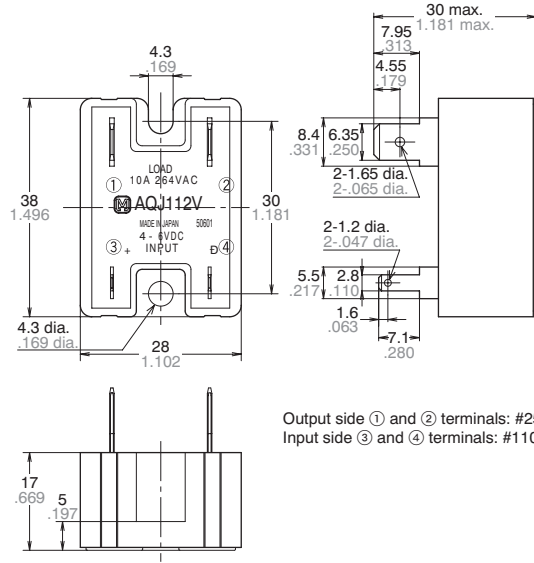

Output side ① and ② terminals: #250 type, t = 0.8 .031
 Input side ③ and ④ terminals: #110 type, t = 0.5 .020

Schematic

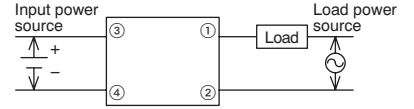

Mounting dimensions

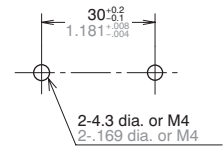

2-(1) Slim Heat Sink Combined Type
Output Arrangement: 1a

[CAD Data](#)

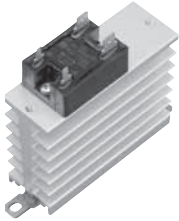

External dimensions

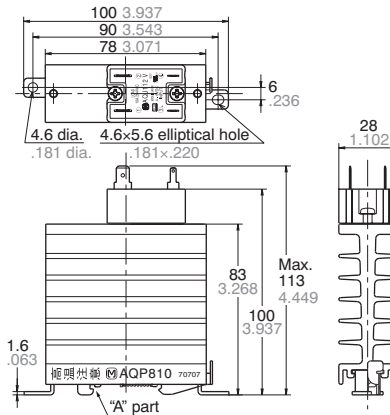

Note: When using on a DIN rail, please install so that the "A" part is on top.

Schematic

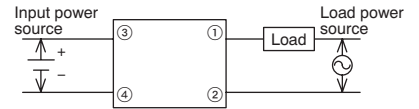

Mounting dimensions (Top view)

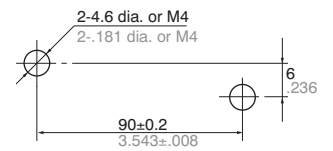

2-(2) Slim Heat Sink Combined Type
Output Arrangement: 1a × 2

[CAD Data](#)

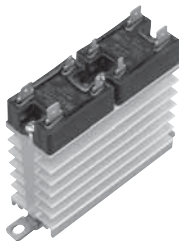

External dimensions

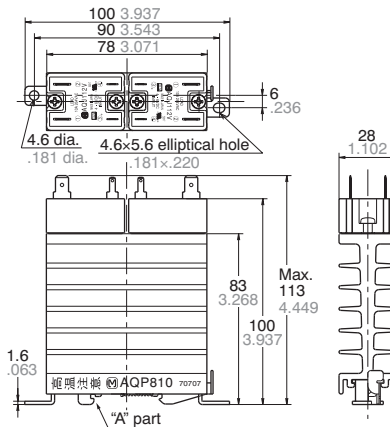

Note: When using on a DIN rail, please install so that the "A" part is on top.

Schematic

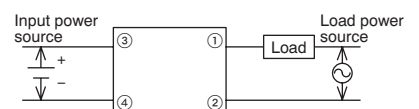

Note: Use caution for AQ-J terminal numbers.

Mounting dimensions (Top view)

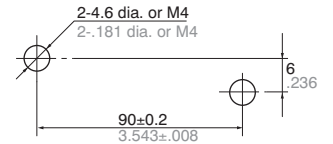

AQ-J

ACCESSORIES

AQP-HS-SJ10A Slim Heat Sink

[CAD Data](#)

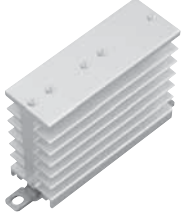

Note: When using on a DIN rail, please install so that the "A" part is on top.

External dimensions

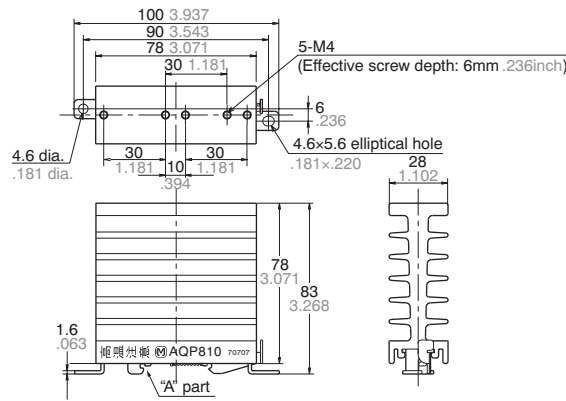

Mounting dimensions (Top view)

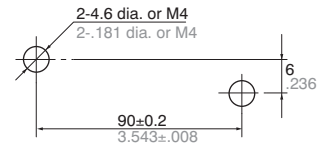

AQP-HS-SJ20A Slim Heat Sink

[CAD Data](#)



Note: When using on a DIN rail, please install so that the "A" part is on top.

External dimensions

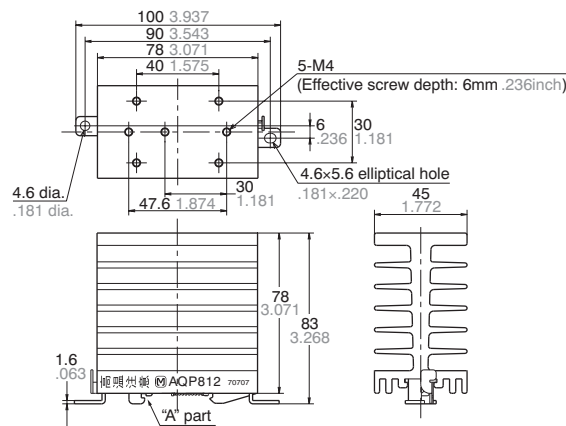

Mounting dimensions (Top view)

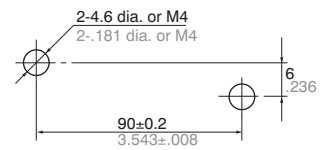

AQP-HS-J10A Standard Heat Sink (for 10A and 15A types)

[CAD Data](#)



External dimensions

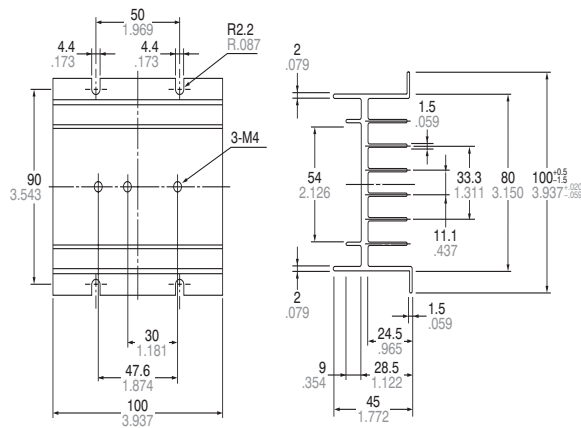

Mounting dimensions

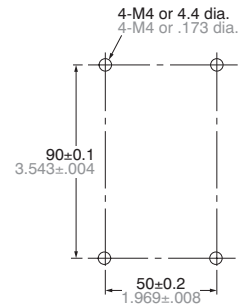

**AQP-HS-J25A Standard Heat Sink
(for 25A type)**

[CAD Data](#)

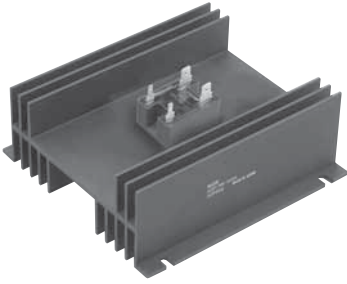

External dimensions

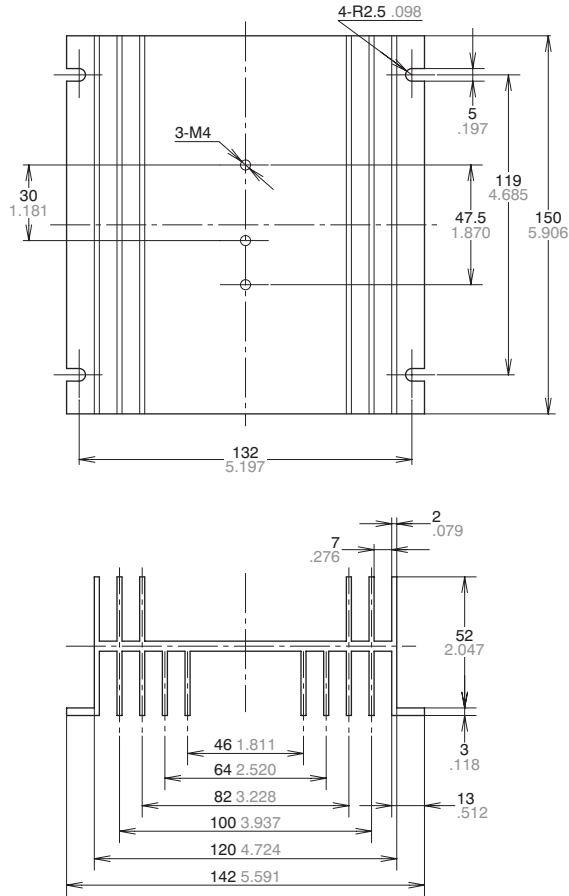

Mounting dimensions

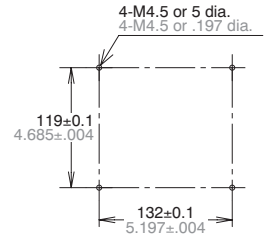

AQP-DPJ DIN Rail Mounting Plate

[CAD Data](#)



External dimensions

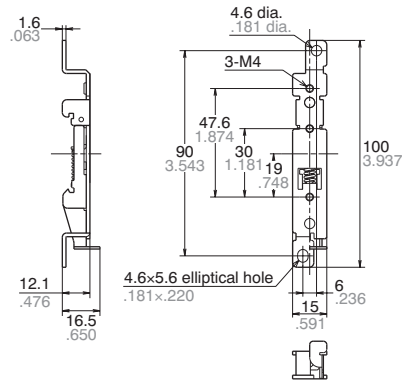

Cautions for Use