



### Main

Range of product	Preventa Safety automation
Product or component type	Safe input expansion module
Device short name	XPSMCM
Electrical connection	Spring terminal
[Us] rated supply voltage	24 V (- 20...20 % DC)
Number of inputs	8 digital
Number of outputs	4 test for line control
Discrete input type	PNP
Discrete output type	PNP
Function of module	Discrete input monitoring safety detection Discrete input monitoring safety dialogue

### Complementary

Power consumption in W	<= 3 W
Power dissipation in W	3 W
Integrated connection type	Backplane expansion bus
Number of terminal blocks	4
Connections - terminals	1-wire spring clamp terminals, removable terminal block 2-wire spring clamp terminals, removable terminal block
Safety level	SILCL 3 conforming to IEC 62061 Can reach category 4 conforming to EN/ISO 13849-1 Can reach PL = e conforming to EN/ISO 13849-1 Can reach SIL 3 conforming to EN/IEC 61508
Quality labels	CE
Discrete input voltage	24 V DC
Local signalling	1 LED green with PWR marking for power ON 1 LED green with RUN marking for RUN (status) 1 LED red with E IN marking for internal error 1 LED red with E EX marking for external error 8 LEDs yellow with IN marking for input status 2 LEDs orange with ADDR marking for node address
Cable cross section	(0.2...2.5 mm <sup>2</sup> - AWG 24...AWG 14) flexible cable without cable end

(0.25...2.5 mm<sup>2</sup> - AWG 23...AWG 14) flexible cable with cable end, with bezel  
 (0.2...2.5 mm<sup>2</sup> - AWG 24...AWG 14) solid cable without cable end  
 (0.25...2.5 mm<sup>2</sup> - AWG 23...AWG 14) flexible cable with cable end, without bezel  
 (0.5...1 mm<sup>2</sup> - AWG 20...AWG 18) flexible cable with cable end, with double bezel

Mounting support	Omega 35 mm DIN rail conforming to EN 50022
Depth	22.5 mm
Height	99 mm
Width	114.5 mm
Product weight	0.23 kg

## Environment

Standards	IEC 62061 EN/ISO 13849-1 EN/IEC 61800-5-1 EN/IEC 61508
Product certifications	TÜV RCM cULus
IP degree of protection	IP20 for enclosure
Ambient air temperature for operation	-10...55 °C
Ambient air temperature for storage	-20...85 °C
Relative humidity	10...95 %
Pollution degree	2
[Uimp] rated impulse withstand voltage	4 kV conforming to EN/IEC 61800-5-1
Safety reliability data	DC > 99 % MTTFd < 100 years at high PFHd = 5.75E-9 1/h
Insulation	250 V AC between power supply and housing conforming to EN/IEC 61800-5-1
Overvoltage category	II
Electromagnetic compatibility	Electrostatic discharge immunity test - test level 6 kV, on contact conforming to EN/IEC 61000-4-2 Electrostatic discharge immunity test - test level 20 kV, on air conforming to EN/IEC 61000-4-2 Susceptibility to electromagnetic fields - test level 10 V/m, 80...1000 MHz conforming to EN/IEC 61000-4-3 Susceptibility to electromagnetic fields - test level 30 V/m, 1.4 GHz...2 GHz conforming to EN/IEC 61000-4-3
Vibration resistance	+/-0.35 mm (f = 10...55 Hz) conforming to EN/IEC 61496-1
Shock resistance	10 gn (duration = 16 ms) shocks : 1000 shocks on each axis EN/IEC 61496-1
Service life	20 yr

## Offer Sustainability

Sustainable offer status	Green Premium product
RoHS (date code: YYWW)	Compliant - since 1450 - Schneider Electric declaration of conformity <a href="#">Schneider Electric declaration of conformity</a>
REACH	Reference not containing SVHC above the threshold <a href="#">Reference not containing SVHC above the threshold</a>
Product environmental profile	Available
Product end of life instructions	Available

Dimensions

Spring Terminal

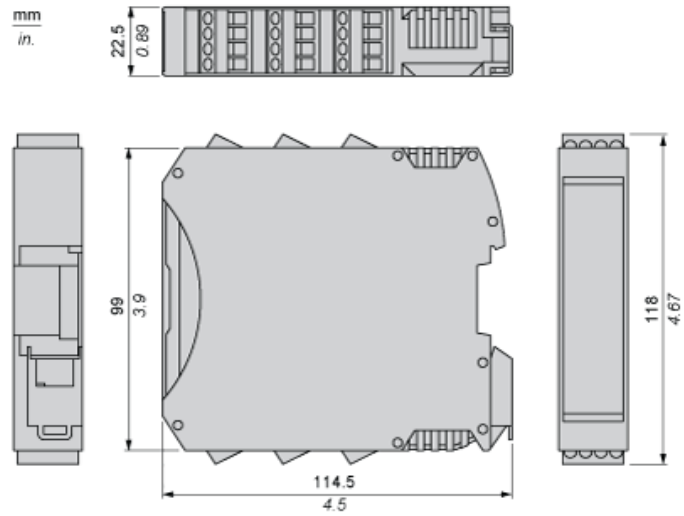

---

Mounting Safety Controller CPU with Module(s)

---

Mount BackPlane Connector on Rail

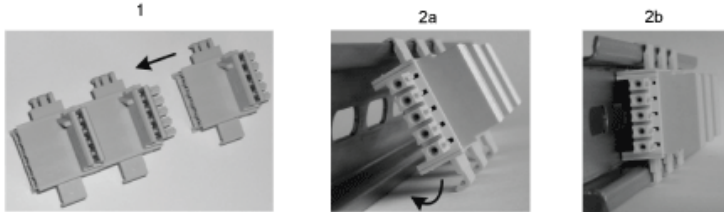

- 1 : Connect as much Backplane Connector as module to be install.
- 2 : Fix the connectors to the rail (Top first).

Mount Safety Controller CPU with Other Module(s)

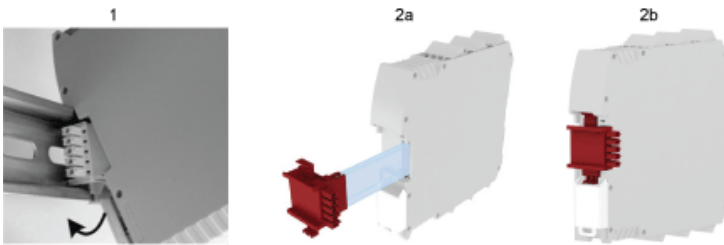

- 1 : Mount controller CPU and modules on rail.
- 2 : Make sure that the controller CPU or the module(s) are plugged on the BackPlane connector.

Wiring

Terminal Designation

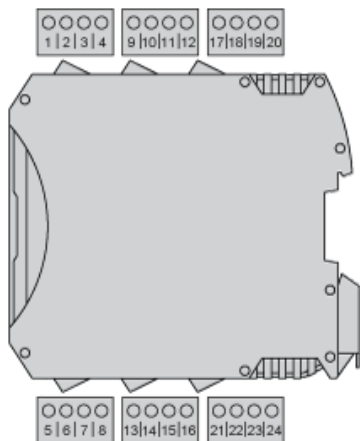

Terminal	Signal	Description
1	24 VDC	24 Vdc power supply
2	NODE_ADDR0	Node selection
3	NODE_ADDR1	
4	0 VDC	0 Vdc power supply
5	INPUT1	Digital input 1
6	INPUT2	Digital input 2
7	INPUT3	Digital input 3
8	INPUT4	Digital input 4
9	OUT_TEST1	Short circuit detected output
10	OUT_TEST2	
11	OUT_TEST3	
12	OUT_TEST4	
13	INPUT5	Digital input 5
14	INPUT6	Digital input 6
15	INPUT7	Digital input 7
16	INPUT8	Digital input 8

# Wiring Example

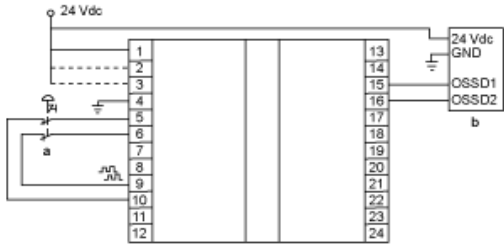

- a : Emergency stop
- b : Light curtain