



Figure similar

LOAD FEEDER FUSELESS REVERSING OPERATION, AC 400V, SZ. S00, 1.4...2A, 24 V DC SCREW CONNECTION FOR MOUNTING ON STANDARD RAIL, TYPE OF COORDINATION 2,IQ = 150KA ALSO FULFILLS TYPE OF COORDINATION 1) 1NC (CONTACTOR) 1NO+1NC (CIRCUIT BREAKER, TRANSVERSE)

product brand name	SIRIUS
Product designation	non-fused load feeders 3RA2
Manufacturer article number	
<ul style="list-style-type: none"> • of the supplied contactor • of the supplied circuit-breakers • of the supplied link module 	3RT2016-1BB42 3RV2011-1BA15 3RA1921-1DA00

General technical data:

Insulation voltage		
<ul style="list-style-type: none"> • with degree of pollution 3 Rated value 	V	690
Shock resistance		
<ul style="list-style-type: none"> • acc. to IEC 60068-2-27 		6g / 11 ms
Surge voltage resistance Rated value	kV	6
Type of assignment		2
Protection class IP		
<ul style="list-style-type: none"> • on the front 		IP20

Main circuit:

Number of poles for main current circuit		3
Adjustable response value current of the current-dependent overload release	A	1.4 ... 2
Operating voltage		
<ul style="list-style-type: none"> • Rated value • at AC-3 Rated value maximum 	V	690
	V	690
Operating frequency Rated value	Hz	50 ... 60
Operating current		
<ul style="list-style-type: none"> • at AC-3 		

— at 400 V Rated value	A	1.9
Operating power		
• at AC-3		
— at 400 V Rated value	W	750
— at 500 V Rated value	W	750
— at 690 V Rated value	W	1 100

Control circuit/ Control:

Control supply voltage for DC		
• Rated value	V	24
Holding power of the magnet coil for DC	W	4

Auxiliary circuit:

Product expansion Auxiliary switch		Yes
---	--	-----

Protective and monitoring functions:

Trip class		CLASS 10
Design of the overload circuit breaker		thermal (bimetallic)

UL/CSA ratings:

Full-load current (FLA) for three-phase AC motor		
• at 480 V Rated value	A	2
yielded mechanical performance [hp]		
• for three-phase AC motor at 460/480 V Rated value	metric hp	0.75
• for three-phase AC motor at 575/600 V Rated value	metric hp	1

Short-circuit:

Product function Short circuit protection		Yes
Design of the short-circuit trip		magnetic
Conditional short-circuit current (I_q)		
• at 400 V acc. to IEC 60947-4-1 Rated value	A	153 000

Installation/ mounting/ dimensions:

mounting position		vertical
Mounting type		screw and snap-on mounting onto 35 mm standard mounting rail
Height	mm	170
Width	mm	90
Depth	mm	97.1
Required spacing		
• for grounded parts		
— forwards	mm	0
— Backwards	mm	0
— upwards	mm	20

— at the side	mm	9
— downwards	mm	10
• for live parts		
— forwards	mm	0
— Backwards	mm	0
— upwards	mm	20
— downwards	mm	10
— at the side	mm	9

Connections/ Terminals:

Type of electrical connection		
• for main current circuit		screw-type terminals

Safety related data:

B10 value with high demand rate acc. to SN 31920		1 000 000
Proportion of dangerous failures		
• with high demand rate acc. to SN 31920	%	73
Protection against electrical shock		finger-safe

Mechanical data:

Size of the circuit-breaker		S00
Size of load feeder		S00

Ambient conditions:

Ambient temperature		
• during operation	°C	-20 ... +60
• during storage	°C	-50 ... +80
• during transport	°C	-50 ... +80

Certificates/ approvals:

General Product Approval	For use in hazardous locations	Declaration of Conformity	Test Certificates
--------------------------	--------------------------------	---------------------------	-------------------



[Type Test Certificates/Test Report](#)

Test Certificates	Shipping Approval	other
-------------------	-------------------	-------

[Declaration of the Compliance with the order](#)

[Special Test Certificate](#)



[Environmental Confirmations](#)

other

[Declaration of Conformity](#)

[other](#)

Further information

Information- and Downloadcenter (Catalogs, Brochures,...)

<http://www.siemens.com/industrial-controls/catalogs>

Industry Mall (Online ordering system)

<http://www.siemens.com/industrymall>

Cax online generator

<http://support.automation.siemens.com/WW/CAXorder/default.aspx?lang=en&mfb=3RA22151BA162BB4>

Service&Support (Manuals, Certificates, Characteristics, FAQs,...)

<http://support.automation.siemens.com/WW/view/en/3RA22151BA162BB4/all>

Image database (product images, 2D dimension drawings, 3D models, device circuit diagrams, EPLAN macros, ...)

http://www.automation.siemens.com/bilddb/cax_de.aspx?mfb=3RA22151BA162BB4&lang=en

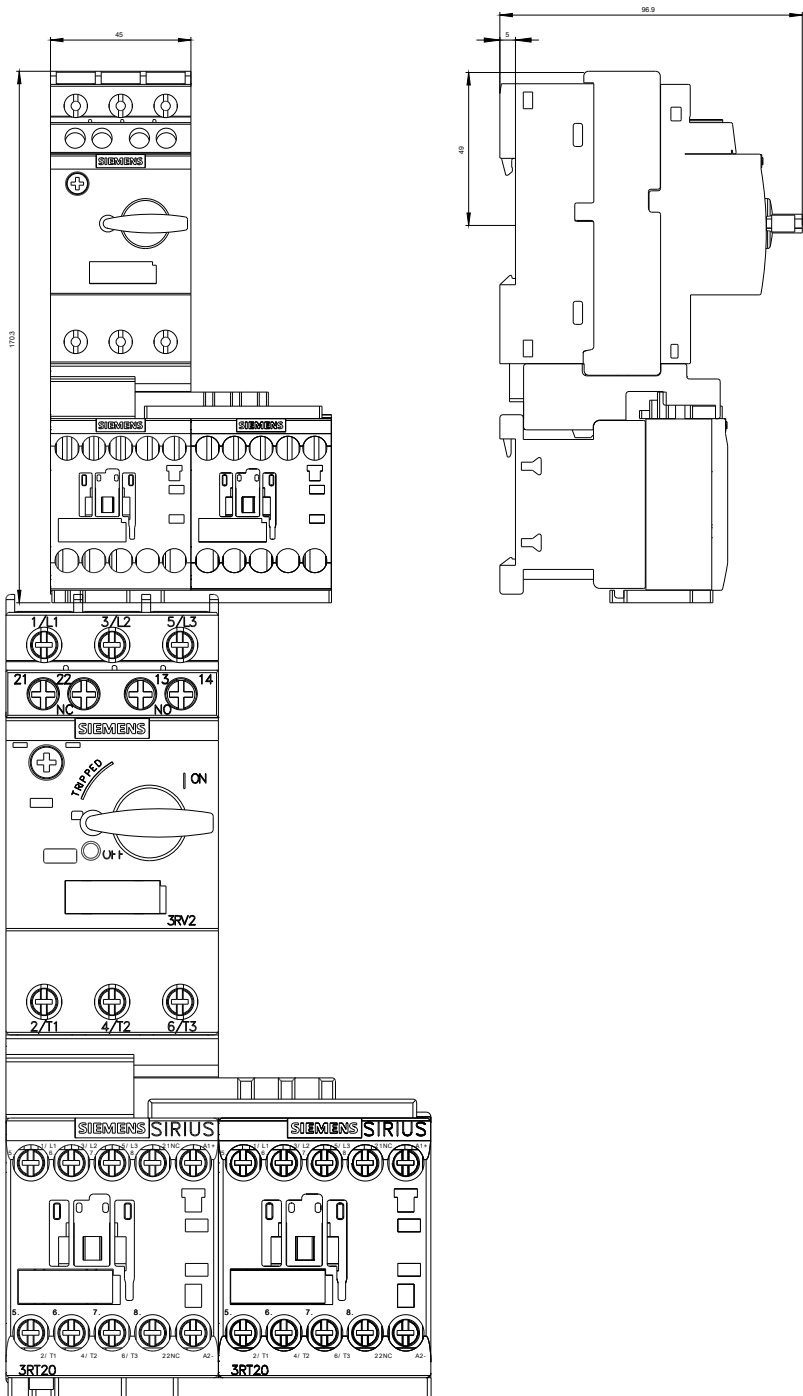

REBR&L&E&T&R&E&Z&V&L&G&S&D&HERUNGSL.

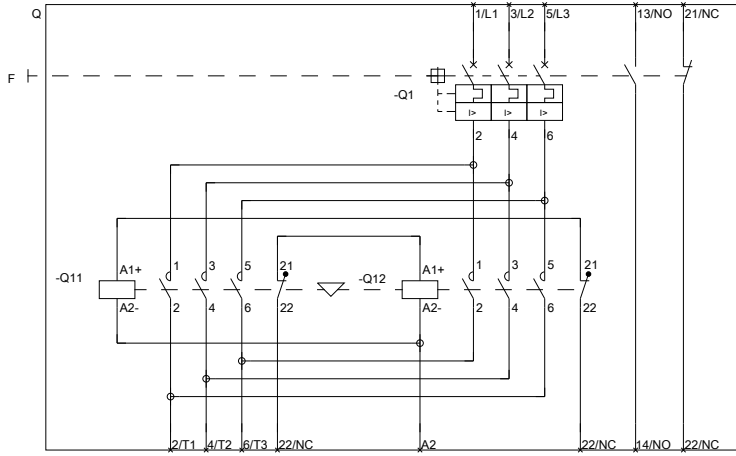

BE&V&RE&N&D&BU&S&A&E&3&3&V.

last modified:

11.03.2015