

Amphenol Canada Corp - Product Change Notice (PCN)

PCN Date	May 16, 2023
Supplier Name:	Amphenol Canada Corp.
Amphenol Canada PCN Number	PCN-C05008
Description of Change	Transfer molding of Lighting Domes from Shenzhen China to Amphenol Cochin India.
Reason for Change	Vertical integration of manufacturing process and lead time reduction.
Summary of changes between new and old part	No changes to parts. Molds to be transferred from Shenzhen to Cochin.
Traceability guidelines (lot code / date code, markings, ship date...)	Will be tracked by date code, see below. Products manufactured in Cochin will also be marked with the character 'K'.
Last Time Buy Date	N/A - Running change to manufacturing location.
Datasheet attached? & Filename(s)	P-FLS-C40-XXX-000-REVB, P-FLS-C80-XXX-000-REVD, P-FLB-C70-XXX-001-REVE
Qual Test data attached? & Filename(s)	

Customer Part Number	Amphenol Part Number	Amphenol Drawing Number	PCN Effectivity Date	PCN Effectivity Date Code	Samples Availability Date	Last Time Buy Date	Expected Supplier Qual Date
	FLS-C40-25X-000	P-FLS-C40-XXX-000	01-Aug-23	2331	01-Jul-23	N/A	01-Aug-23
	FLS-C40-40X-000		01-Aug-23	2331	01-Jul-23	N/A	01-Aug-23
	FLS-C80-35X-000	P-FLS-C80-XXX-000	01-Oct-23	2339	01-Sep-23	N/A	01-Oct-23
	FLS-C80-50X-000		01-Sep-23	2335	01-Aug-23	N/A	01-Sep-23
	FLS-C80-60X-000		01-Sep-23	2335	01-Aug-23	N/A	01-Sep-23
	FLS-C80-75X-000		01-Oct-23	2339	01-Sep-23	N/A	01-Oct-23
	FLS-C80-10X-000		01-Oct-23	2339	01-Sep-23	N/A	01-Oct-23
	FLB-C70-35X-001		01-Oct-23	2339	01-Sep-23	N/A	01-Oct-23
	FLB-C70-50X-001	P-FLB-C70-XXX-001	01-Sep-23	2335	01-Aug-23	N/A	01-Sep-23
	FLB-C70-60X-001		01-Sep-23	2335	01-Aug-23	N/A	01-Sep-23
	FLB-C70-75X-001		01-Oct-23	2339	01-Sep-23	N/A	01-Oct-23
	FLB-C70-10X-001		01-Oct-23	2339	01-Sep-23	N/A	01-Oct-23

Form # 9011065, Rev A

Rev A Released MAY17, 2023

REVISIONS			
REV	DESCRIPTION, ECN, EAR NO.	DATE	APP'D
A	PROPOSAL DRAWING	AUG19/19	S.M
B	MODIFIED INTERNAL CAVITY	AUG22/19	S.M

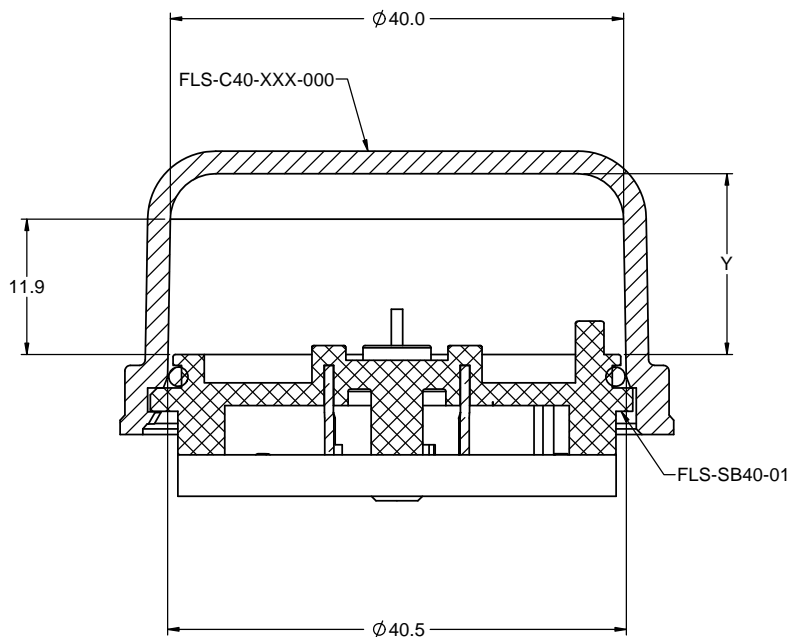
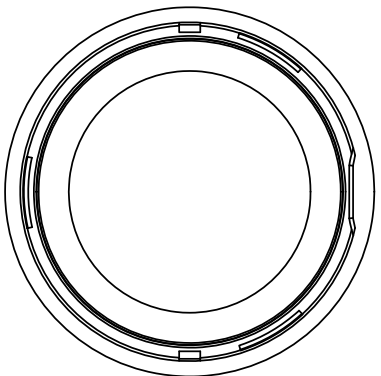
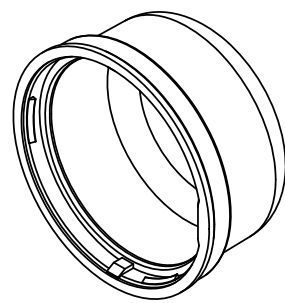
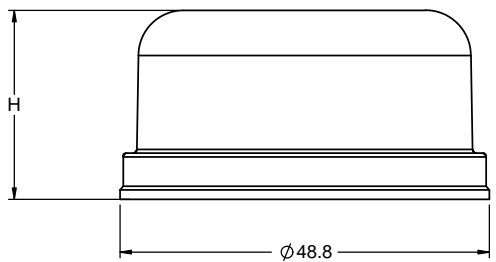

NAMING SYSTEM FLS - C40 - XX X -000

HEIGHT "H"

XX	"H"	"Y"
25	25 mm	16.0 mm
40	40 mm	31.0 mm

COLOUR
1 - GREY
2 - CLEAR

NOTES:
MATERIALS:
HOUSING: POLYCARBONATE, UL 94-5V A RATED
COLOR: AS PER PART NUMBERING SYSTEM

AMPHENOL PART NUMBER: FLS-C40-XXX-000



UNLESS SPECIFIED OTHERWISE	DRAWN	I.NELSON	JUL31/19
PRIMARY UNITS MILLIMETERS	CHECKED	S.MUGAN	AUG19/19
SECONDARY	M.E. APP'D		
REFERENCE IN PARENTHESES	Q.A. APP'D		
GENERAL TOLERANCES	DWG APPR.		
1 DECIMAL PLACE ±0.2	ENG. REL. NO.		
2 DECIMAL PLACES	REF.		
3 DECIMAL PLACES	THIRD ANGLE PROJECTION		
ANGULAR DEGREES	DO NOT SCALE DRAWING		

Amphenol Canada Corp.
Commercial Products

FLS SERIES
DOME COVER 40 mm DIA
MULTIPLE HEIGHTS
RoHS COMPLIANT

DWG. NO. **P-FLS-C40-XXX-000** REV **B**

CODE ID NO. 03554 DWG SIZE: X SCALE: 2:1 SHEET 1 OF 1

THIS DOCUMENT CONTAINS PROPRIETARY INFORMATION AND SUCH INFORMATION MAY NOT BE DISCLOSED TO OTHERS FOR ANY PURPOSE OR USED FOR MANUFACTURING PURPOSES WITHOUT WRITTEN PERMISSION FROM AMPHENOL CANADA CORP.

Rev A Released MAY17, 2023

REVISIONS			
REV	DESCRIPTION, ECN, EAR NO.	DATE	APPD
C	COLOR CODES AND HEIGHTS UPDATED	JUN23/20	S.M
D	13 HEIGHT UPDATED	JUN26/20	S.M

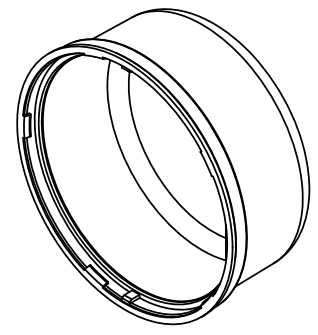
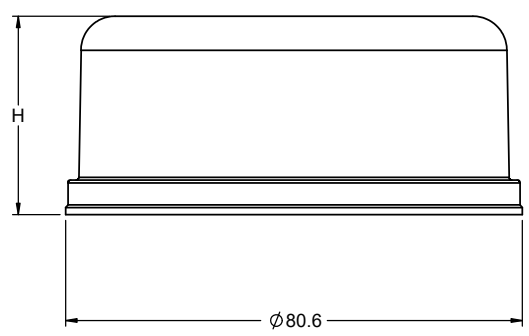

NOTES:
MATERIALS:
HOUSING: POLYCARBONATE, UL 94- 5V A RATED
COLOR AS PER PART NUMBERING SYSTEM

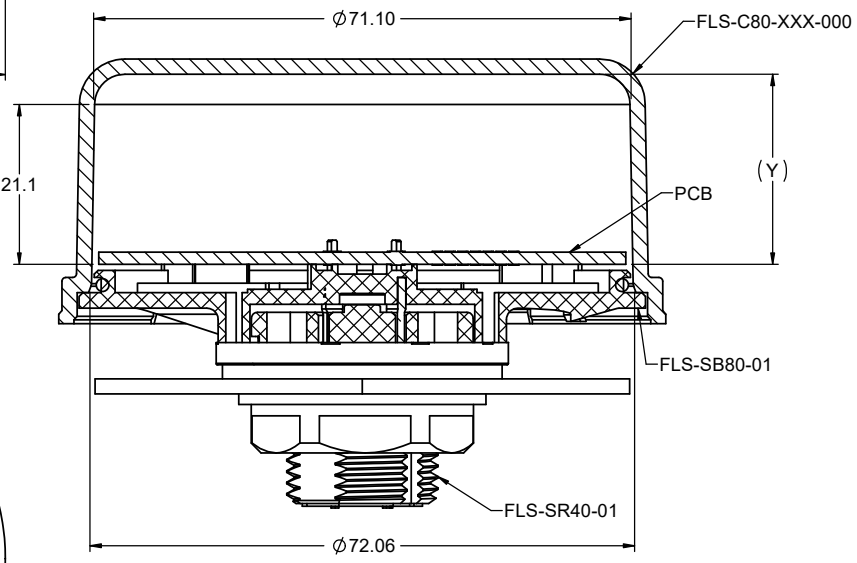

PARTIAL SECTION VIEW

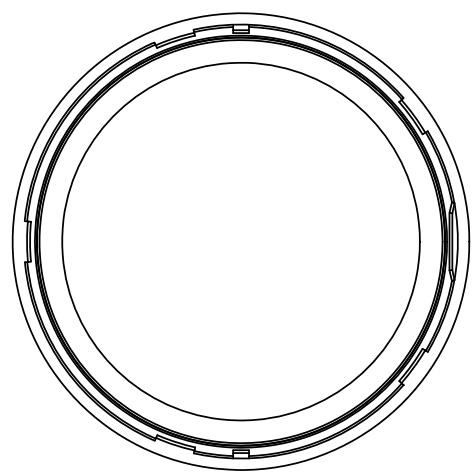

HEIGHT

XX	"H"	"Y"
35	35 mm	25.2 mm
50	50 mm	40.2 mm
60	60 mm	50.2 mm
75	75 mm	65.2 mm
10	100 mm	90.2 mm
13	130 mm	120.2 mm

COLOUR

- 1 - GREY
- 2 - CLEAR
- 3 - RED
- 4 - BLACK
- 5 - WHITE
- 6 - TRANSLUCENT

AMPHENOL PART NUMBER: FLS-C80-XXX-000



UNLESS SPECIFIED OTHERWISE	DRAWN	I.NELSON	JUL30/19
PRIMARY UNITS MILLIMETERS	CHECKED	S.MUGAN	AUG19/19
SECONDARY	M.E. APPD		
REFERENCE IN PARENTHESES	Q.A. APPD		
GENERAL TOLERANCES	DWG APPR.		
1 DECIMAL PLACE ± 0.2	ENG. REL. NO.		
2 DECIMAL PLACES	REF.		
3 DECIMAL PLACES	THIRD ANGLE PROJECTION		
ANGULAR DEGREES	DO NOT SCALE DRAWING		

Amphenol Canada Corp.
Commercial Products
FLS SERIES
DOME COVER 80 mm DIA
MULTIPLE HEIGHTS
RoHS COMPLIANT

DWG. NO. **P-FLS-C80-XXX-000** REV **D**

CODE ID NO. 03554 DWG SIZE: X SCALE: 1:1 SHEET 1 OF 1

THIS DOCUMENT CONTAINS PROPRIETARY INFORMATION AND SUCH INFORMATION MAY NOT BE DISCLOSED TO OTHERS FOR ANY PURPOSE OR USED FOR MANUFACTURING PURPOSES WITHOUT WRITTEN PERMISSION FROM AMPHENOL CANADA CORP.

Rev A Released MAY17, 2023

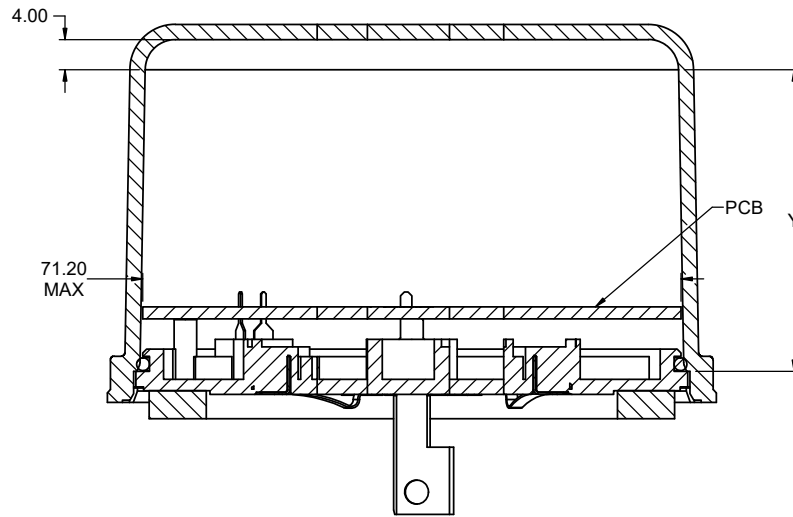
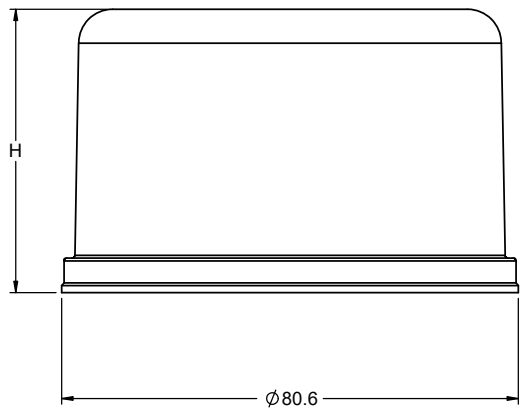

SHOWN WITH FLB-P7X-001

REVISIONS			
REV	DESCRIPTION, ECN, EAR NO.	DATE	APPD
D	COLOR CODING UPDATED	JUN23/20	S.M
E	PART NUMBER UPDATED	AUG11/20	S.M

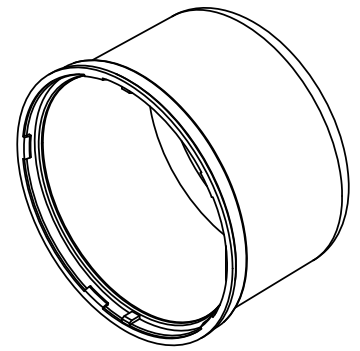

NOTES:
MATERIALS:
HOUSING: POLYCARBONATE, UL 94- 5V A RATED
COLOR AS PER PART NUMBERING SYSTEM

FLB-C70-XX X-001

HEIGHT

XX	"H"	"Y"
35	35 mm	24.9 mm
50	50 mm	39.9 mm
60	60 mm	49.9 mm
75	75 mm	64.9 mm
10	100 mm	89.9 mm
13	130 mm	119.9 mm

COLOUR

- 1 - GREY
- 2 - CLEAR
- 3 - RED
- 4 - BLACK
- 5 - WHITE
- 6 - TRANSLUCENT

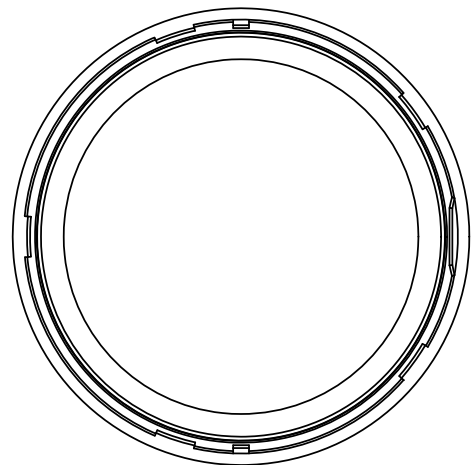

AMPHENOL PART NUMBER: FLB-C70-XXX-001

UNLESS SPECIFIED OTHERWISE	DRAWN	S.MUGAN	MAY14/20
PRIMARY UNITS MILLIMETERS	CHECKED	A.GREEN	MAY14/20
SECONDARY	M.E. APPD		
REFERENCE IN PARENTHESES	Q.A. APPD		
GENERAL TOLERANCES	DWG APPR.		
1 DECIMAL PLACE ± 0.2	ENG. REL. NO.		
2 DECIMAL PLACES	REF.		
3 DECIMAL PLACES	THIRD ANGLE PROJECTION		
ANGULAR DEGREES	DO NOT SCALE DRAWING		

Amphenol Canada Corp.
Commercial Products
FLB SERIES
DOME COVER
MULTIPLE HEIGHTS
RoHS COMPLIANT

DWG. NO. **P-FLB-C70-XXX-001** REV **E**

CODE ID NO. 03554 DWG SIZE: X SCALE: 1:1 SHEET 1 OF 1

THIS DOCUMENT CONTAINS PROPRIETARY INFORMATION AND SUCH INFORMATION MAY NOT BE DISCLOSED TO OTHERS FOR ANY PURPOSE OR USED FOR MANUFACTURING PURPOSES WITHOUT WRITTEN PERMISSION FROM AMPHENOL CANADA CORP.