

MONTAGEDURCHBRUCH
 PANEL CUT-OUT

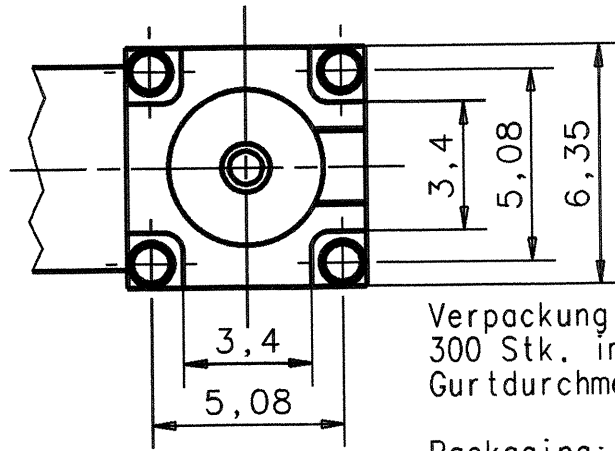
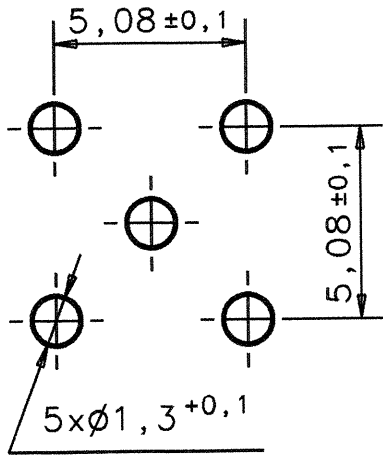

Verpackung:
 300 Stk. im Blistergurt
 Gurtdurchmesser 330mm

Packaging:
 300 pcs. in tape and reel
 Reel diameter 330mm.

Oberfläche Gehäuse /
 Surface body
 Optalloy with flash gold

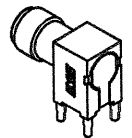
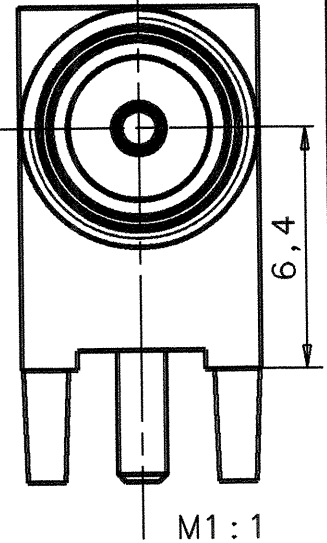
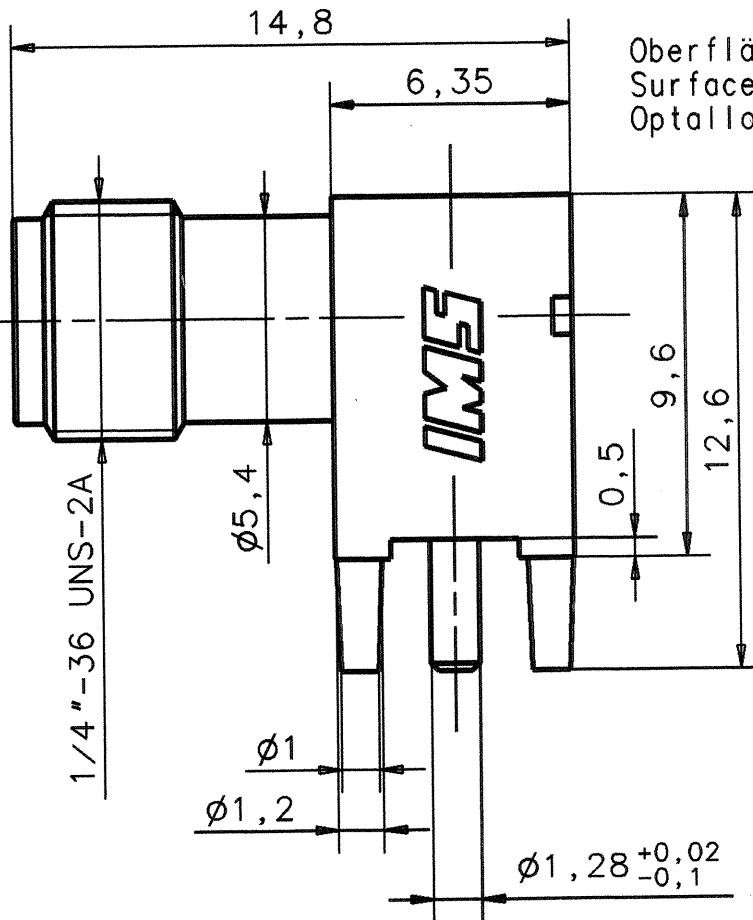
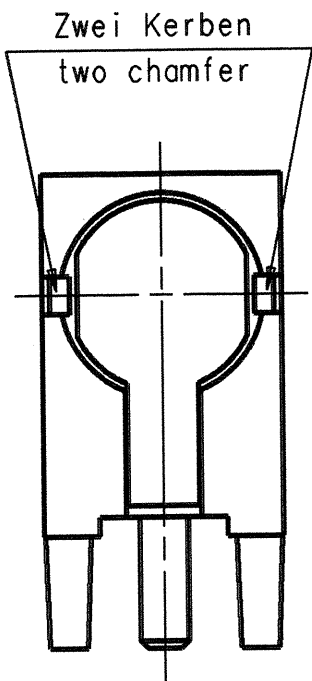

Gestellware	Ja	Nein	Werkstueckkanten:	-0.1	+0.1	Grosserienteil gefertigt nach Anlage	Ja
Verpackung	NR. : AGK 3116		DIN-6784			AGK 2677, AGK 2678, AGK 2679	
	Anzahl: 300		() Konstruktions-	Masse werden bei Abnahme		Werkstueckvolumen	Werkstueckoberflaeche
QP	<input checked="" type="checkbox"/>	TM	masse	gesondert geprueft: DIN-406		V = mm³	A = mm²
IMS CONNECTOR SYSTEMS GMBH			ALLGEMEINTOL. ISO 2768 mH		Masstab: 5:1		
			Datum		Name		
			Bearb. 18.12.96		Schwaer		
			Gepr.				
			Norm				
685/99	e	Blistergurt hinzu/ Tape and reel addition	11.10.99	RSc			
343/98	d	Zwei Kerben / Two chamfer Deckel geo. / modify cover	07.07.98	RSc			
265/98	c	Ø 1,28 mm → Ø 1,28 mm	02.06.98	RSc			
ENTWURF	b	IMS SCHRIFT NEU IMS NEW	11.12.97	RSc			
ENTWURF	a	NEUES DESIGN NEW DESIGN	28.11.97	RSc			
Nr.	Zust.	Aenderung	Datum	Name	2018.42.2520.00'		
							Rev.
							e