

O4E501

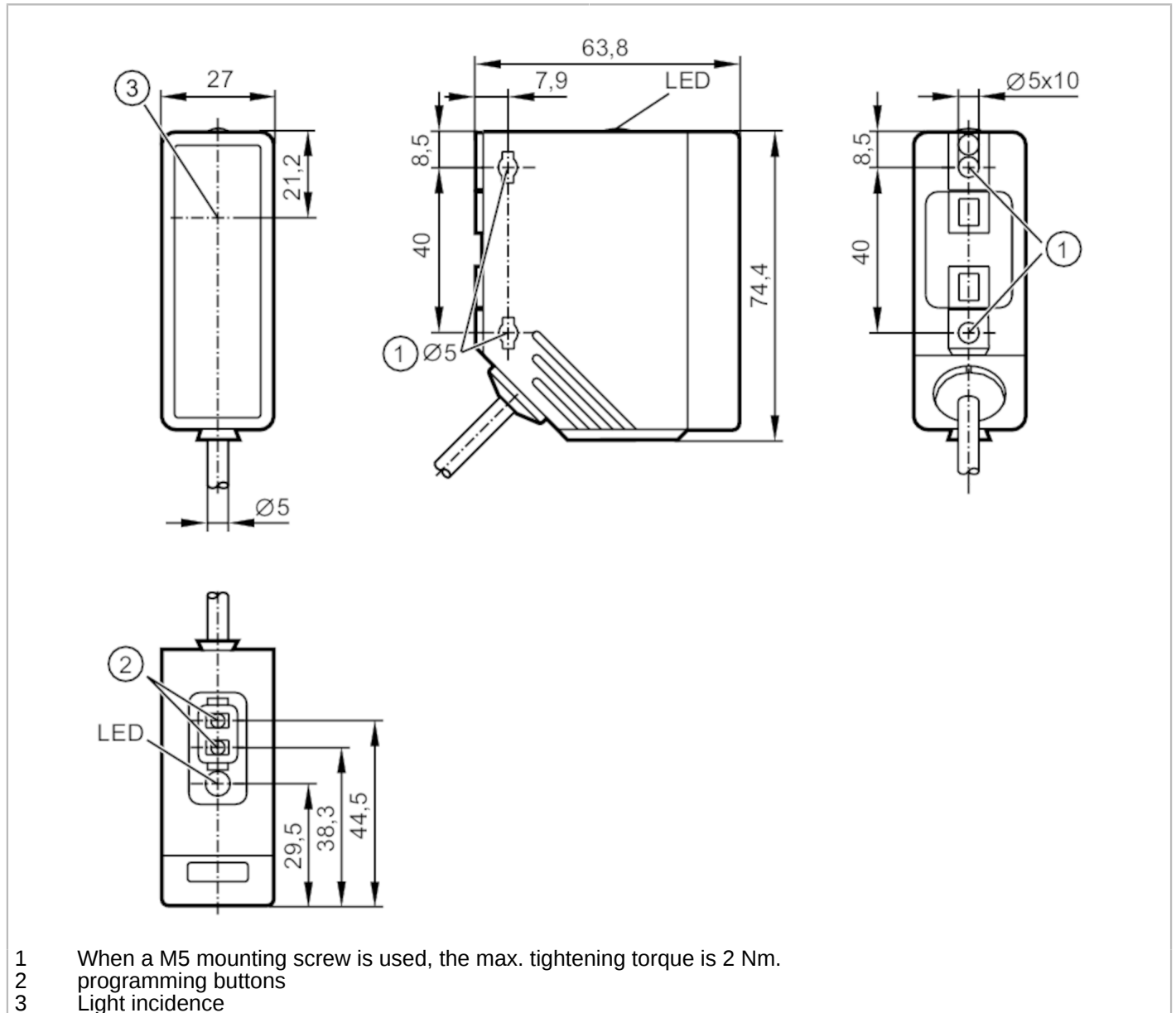

Through-beam sensor receiver

O4E-FPKG/2M



Product characteristics

Type of light	red light
Housing	rectangular
Dimensions [mm]	74.4 x 27 x 63.8

Application

Function principle	Through-beam sensor
--------------------	---------------------

O4E501



Through-beam sensor receiver

O4E-FPKG/2M

Electrical data		
Operating voltage	[V]	10...36 DC
Current consumption	[mA]	12
Protection class		II
Reverse polarity protection		yes
Type of light		red light
Wave length	[nm]	624
Outputs		
Electrical design		PNP
Output function		light-on/dark-on mode; (programmable)
Max. voltage drop switching output DC	[V]	2.5
Permanent current rating of switching output DC	[mA]	200
Switching frequency DC	[Hz]	1000
Short-circuit protection		yes
Type of short-circuit protection		pulsed
Overload protection		yes
Detection zone		
Transmitter / receiver		receiver
Range	[m]	0...80
Range adjustable		yes
Operating conditions		
Ambient temperature	[°C]	-25...60
Protection		IP 67
Tests / approvals		
EMC		EN 60947-5-2
MTTF	[years]	785
Mechanical data		
Weight	[g]	206.5
Housing		rectangular
Dimensions	[mm]	74.4 x 27 x 63.8
Materials		housing: PA; bezel: stainless steel; operator interface: TPE
Lens material		PMMA
Lens alignment		side lens
Displays / operating elements		
Display	switching status	1 x LED, yellow
Teach function		yes
Electronic lock		yes
Remarks		
Remarks		operating voltage "supply class 2" according to cULus
Pack quantity		1 pcs.

O4E501



Through-beam sensor receiver

O4E-FPKG/2M

Electrical connection

Cable: 2 m, PUR; 3 x 0.34 mm²

Connection

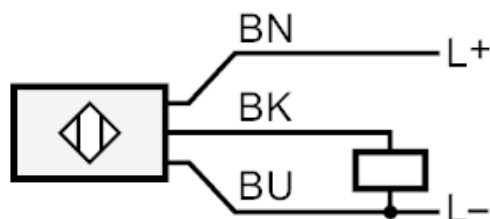

Core colours :

BK = black
BN = brown
BU = blue

Diagrams and graphs

excess gain graph

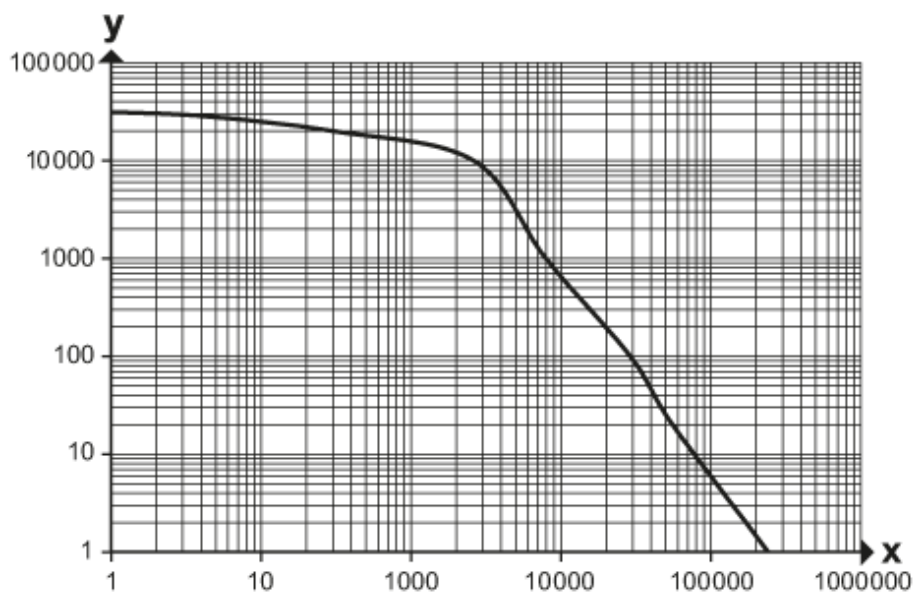

x: Abstand [mm]

y: Funktionsreservfaktor