

# O6E307

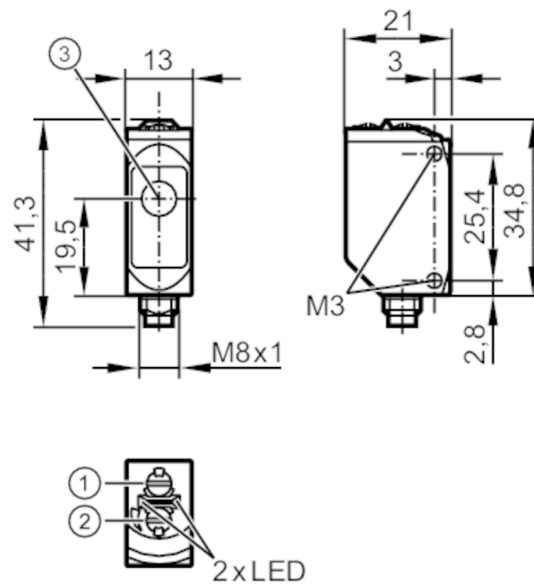

## Through-beam sensor receiver

O6E-FNKG/AS/4P



- 1: output function switch  
 2: potentiometer sensitivity  
 3: Light incidence



### Product characteristics

Type of light	red light
Housing	rectangular
Dimensions [mm]	34.8 x 13 x 21

### Application

Function principle	Through-beam sensor
--------------------	---------------------

### Electrical data

Operating voltage [V]	10...30 DC
Current consumption [mA]	7; ((24 V))
Protection class	III
Reverse polarity protection	yes
Type of light	red light
Wave length [nm]	633

### Outputs

Electrical design	NPN
Output function	light-on/dark-on mode; (selectable)
Max. voltage drop switching output DC [V]	2.5
Permanent current rating of switching output DC [mA]	100
Switching frequency DC [Hz]	1000
Short-circuit protection	yes
Type of short-circuit protection	pulsed

# O6E307



## Through-beam sensor receiver

O6E-FNKG/AS/4P

Detection zone		
Transmitter / receiver		receiver
Range [m]		< 10
Range adjustable		yes
Operating conditions		
Ambient temperature [°C]		-25...80
Protection		IP 65; IP 67; IP 68; IP 69K
Tests / approvals		
EMC	EN 60947-5-2	
MTTF [years]		1014
UL approval	UL Approval no.	E001
Mechanical data		
Weight [g]		36
Housing		rectangular
Dimensions [mm]		34.8 x 13 x 21
Materials	housing: stainless steel (1.4404 / 316L); plastics: PPSU; Sealing: EPDM	
Lens material		PMMA
Lens alignment		side lens
Displays / operating elements		
Display	switching status	1 x LED, yellow
	operation	1 x LED, green
Remarks		
Remarks	operating voltage "supply class 2" according to cULus	
Pack quantity	1 pcs.	
Electrical connection		
Connector: 1 x M8		
		

## Through-beam sensor receiver

O6E-FNKG/AS/4P

### Connection



### Diagrams and graphs

excess gain graph

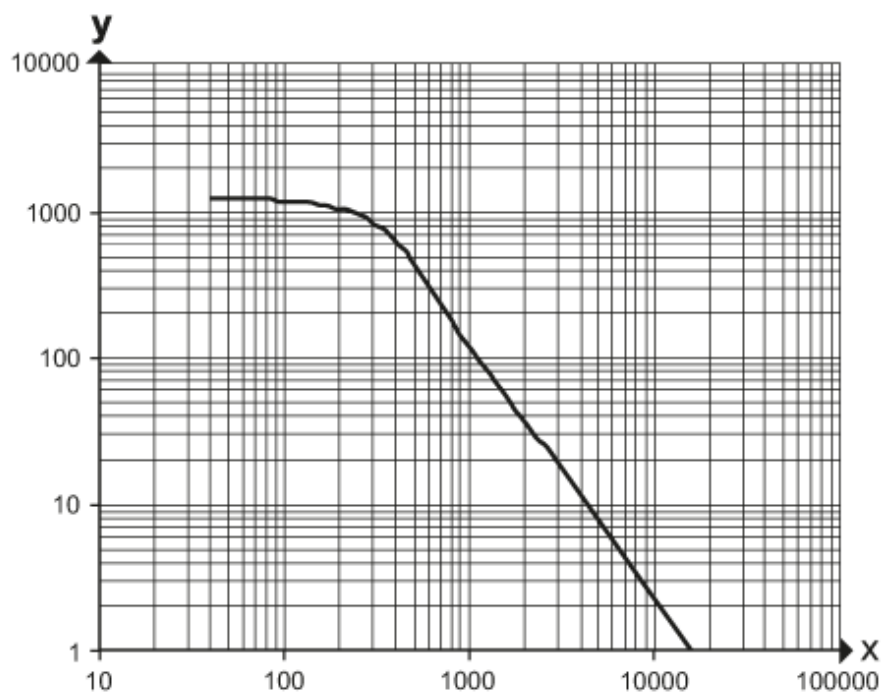

x: distance [mm]

y: excess gain factor