

Data Sheet

powered by RICH BAY

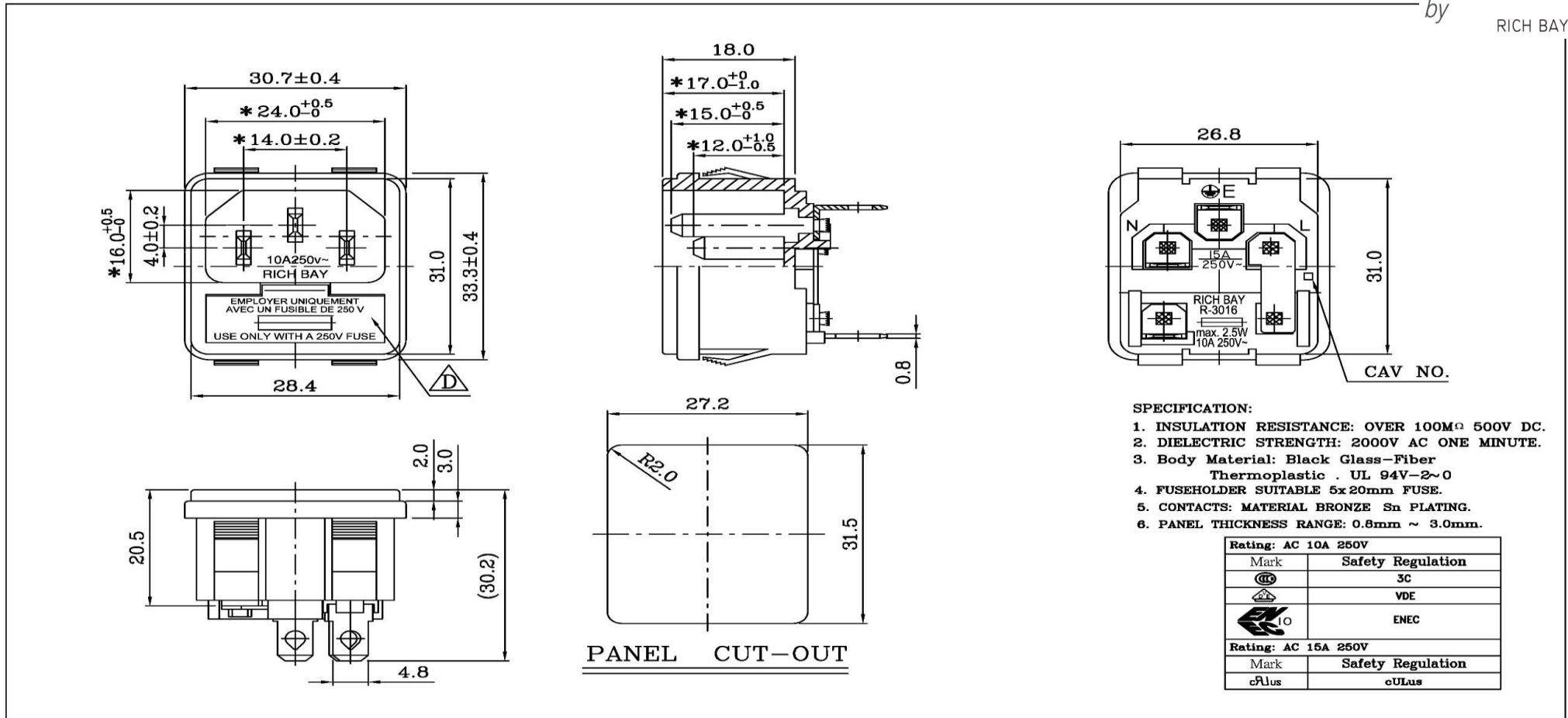

- SPECIFICATION:**
- INSULATION RESISTANCE: OVER 100MΩ 500V DC.
 - DIELECTRIC STRENGTH: 2000V AC ONE MINUTE.
 - Body Material: Black Glass-Fiber Thermoplastic . UL 94V-2~0
 - FUSEHOLDER SUITABLE 5x20mm FUSE.
 - CONTACTS: MATERIAL BRONZE Sn PLATING.
 - PANEL THICKNESS RANGE: 0.8mm ~ 3.0mm.

Rating: AC 10A 250V	
Mark	Safety Regulation
	3C
	VDE
	ENEC
Rating: AC 15A 250V	
Mark	Safety Regulation
cULus	cULus

	UNIT	UNIT QTY	SCALE	TOLERANCE	X.XX±0.1 XX.XX±0.2 XXX.XX±0.3	PRODUCT NO.	R-3016(B200)	REV
	mm	1	1:1					
DRAWN BY	李 2020.12.31 小英	APPROVED BY	朱 2020.12.31 显德	ID NO	20123106Q	INTERIM NO.		D
				DESCRIPTION		NEW NO.		