

SECTION X-X

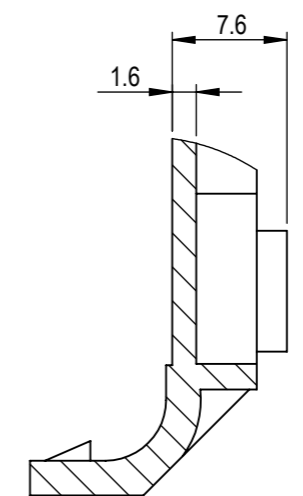

DETAIL Y
SCALE 2 : 1

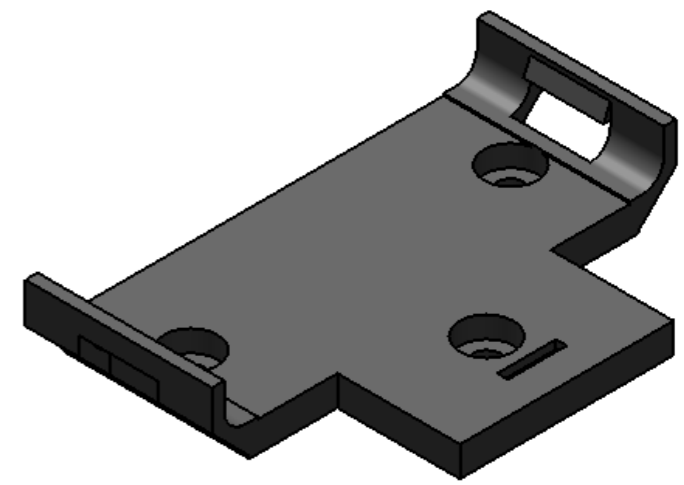
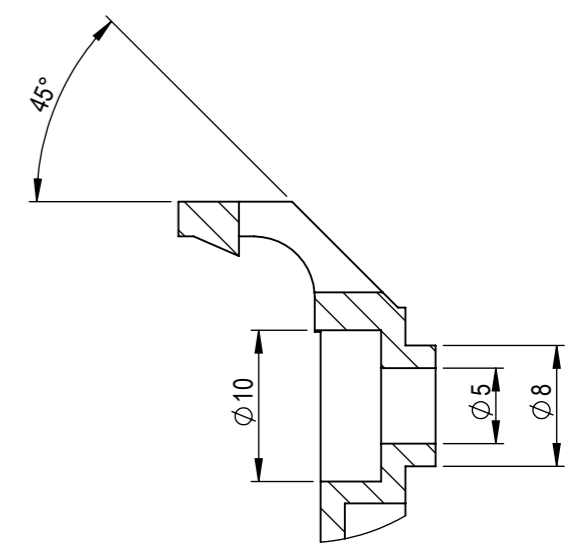

DETAIL Z
SCALE 2 : 1

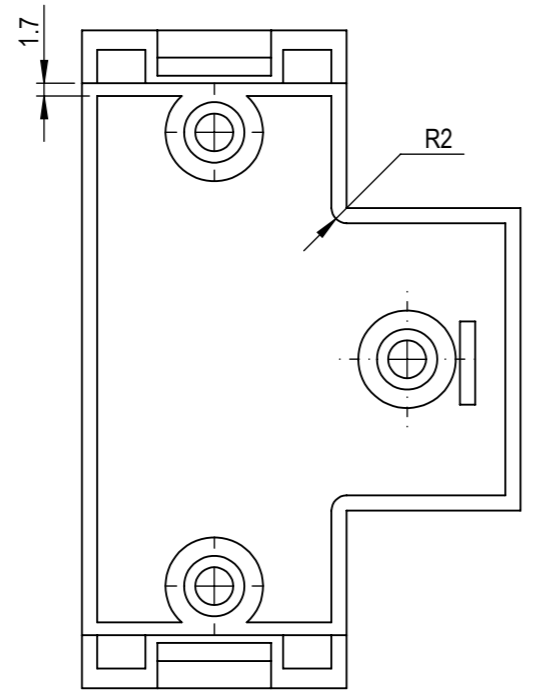

NOTE:
 1. WALL THICKNESS 2mm GENERAL, EXCEPT WHERE SHOWN
 2. DRAFT ANGLE 1° MAX OR DISCRETION OF MOULDER

USED ON
 PV3s, PV6s, PV3i, DD 12-24 (072), DD 48-12 (072)

15/12/11	Drawings separated	3
16/08/11	Material desc changed	2
04/08/11	Added DDi 12-12 108	1
27/07/11	V0 added to mat desc	F
21/05/09	Redrawn in SW	E
19/05/09	DD Range added	D
01/09/04	Hole dims added	C
12/11/99	Screw cover tapered	B
22/10/99	Initial Issue	A
Date	Modification	Iss

Alfatronix ★★★★★

Unit 29, Newtown Business Park
 Poole, Dorset, BH12 3LL
 TEL: +44 (0)1202 715517
 FAX: +44 (0)1202 715122
 email: sales@alfatronix.co.uk

	SCALE	1:1	SHEET SIZE	A3	DESCRIPTION						
						Mounting Cradle Small					
	ENG. APP.	AJP	DATE	09/04/2010	DRAWN	AJP	DATE	21/05/2009	FIRST USED ON	50mm	72mm
	PROD. APP.	CJB	DATE	09/04/2010	DRAWING NUMBER		4129		SHEET	1 OF 1	
									ISSUE	3	
									DATE	15/12/11	

MATERIAL: 10% GLASS FILLED POLYCARBONATE BLACK V0 UL APPROVED
 TREATMENT: REMOVE ALL MOULDING FLASH

© ALFATRONIX LTD. 2009 THIS DRAWING REMAINS THE PROPERTY OF ALFATRONIX LTD. AND MUST NOT BE REPRODUCED WITHOUT PRIOR WRITTEN CONSENT OF THE COMPANY