

No.	Changes and/or Note No.	Date	Intr.	No.	Changes and/or Note No.	Date	Intr.
-----	-------------------------	------	-------	-----	-------------------------	------	-------

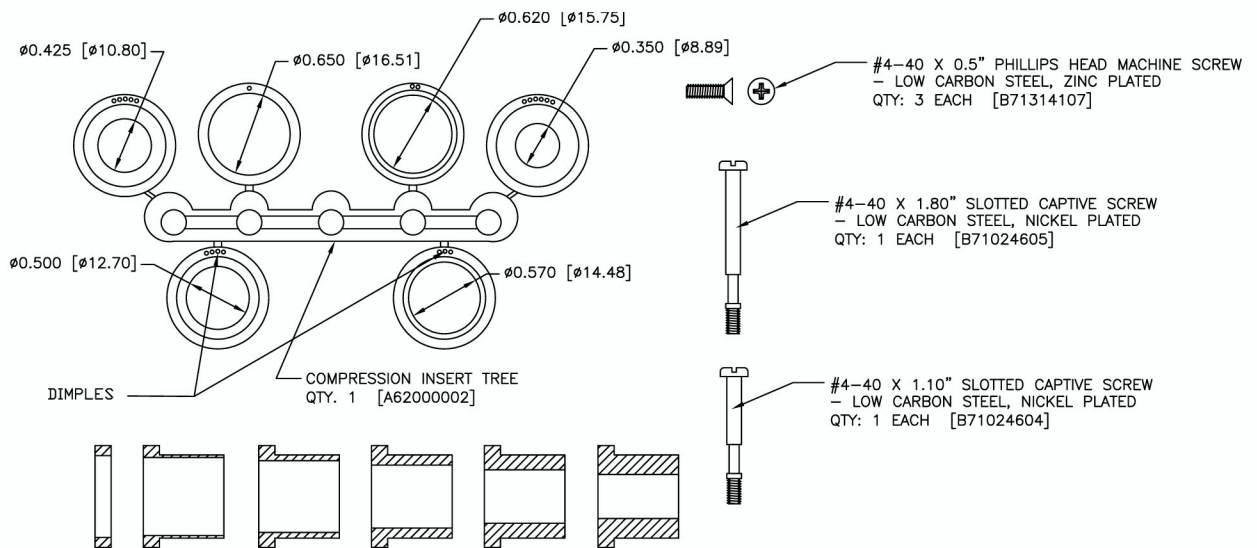
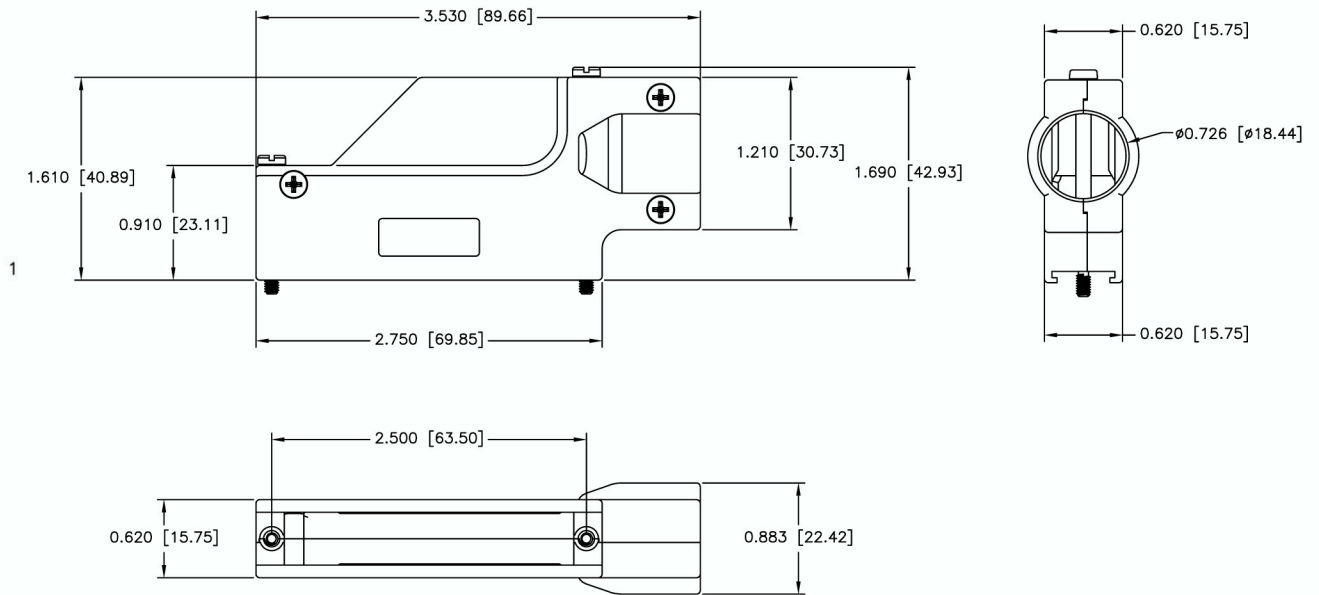

**CONNECTOR COVER:**

- 1.MATERIAL: ZINC ALLOY
- 2.FINISH: SEMI BRIGHT NICKEL PLATING PER NTC SPECIFICATION N/T 000400
- 3.DIMENSIONS: INCHES [MM]
- 4.TOLERANCE:  $\pm 0.015$  [0.381]

**COMPRESSION INSERT TREE**

- 1.MATERIAL: THERMOPLASTIC COMPOUND
- 2.COLOR: BLACK
- 3.DUROMETER: 80  $\pm 3$  TYPE A PER ASTM D2240
- 4.DIMENSIONS: INCHES [MM]
- 5.TOLERANCE:  $\pm 0.020$  [0.508]

DATE 090312	DRAWN MRR	SCALE	MATERIAL TYPE
	APPROVED		REPLACES
DCMR37 - Full Metal Hood Kitted Part : 1060-0135-04 Pack of 100: 1061-0135-04			DRAWING No DCMR37-001