

**Accessories for actuator/sensor cables
female flange with strands, front-mounted
EC-FKD4.5-0,5/16**

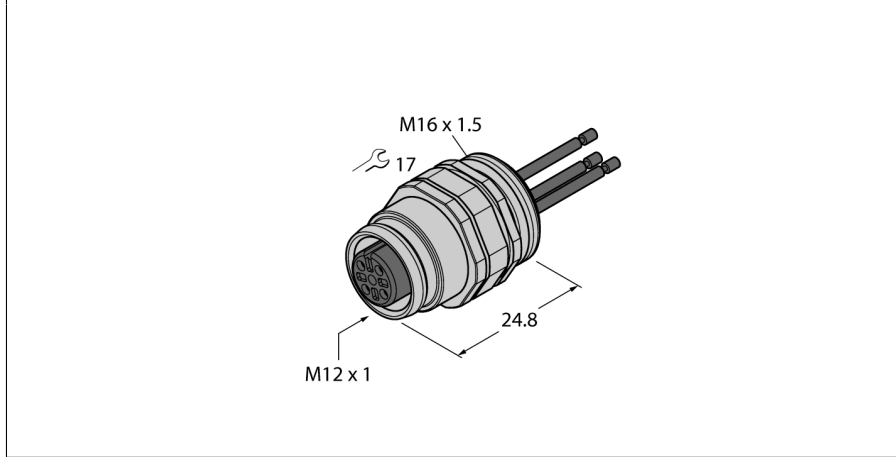

- M12 ⚡ 1 female receptacle
- Protection class IP67
- Front panel mounting
- Connected via stranded wires

Pin Assignment

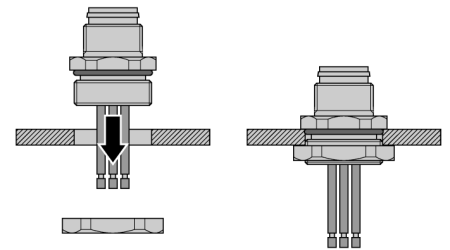
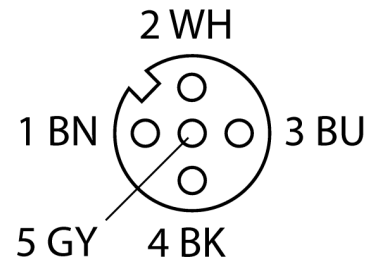

Type designation	EC-FKD4.5-0,5/16
Ident no.	6934165
Connector A side	Female receptacle, M12 ⚡ 1, Straight
Number of pins	5
Contacts	Brass, CuZn, Gold-plated
Contact carriers	Plastic, TPU, Black
Flange housing	Brass, CuZn, nickel-plated
Seal	Plastic, FPM/FKM
Screw-in thread seal	plastic, NBR
Screw-in thread	M16x1.5
Connection mode	Wire connection
Mechanical lifespan	> 100 Mating cycles
Pollution degree	3
Protection class	IP67, (screwed together)
Cable length	0.5 m
Core insulation	PVC
Core colors	BN, WH, BU, BK, GY
Core cross-section	5x0.34mm ²
Electrical features at +20 °C	
Rated voltage	60 V
Current	4 A
Insulation resistance	≥ 10 ⁸ Ω
Forward resistance	≤ 5 mΩ
Mechanical and chemical properties	
Ambient temperature	
Stationary	-30...+90°C