



Main

Range of product	Harmony XAC
Product or component type	Pendant control station
Device short name	XACA

Complementary

Control station type	Double insulated
Enclosure material	Polypropylene
Electrical circuit type	Control circuit
Enclosure type	Complete ready for use
Control station application	Control of single speed hoist motor
Control station composition	2 push-buttons
Control button type	First push-button 1 NC + 1 NO raise, slow Second push-button 1 NC + 1 NO lower, slow
Product compatibility	ZB2BE102 + ZB2BE101 for each direction
Mechanical interlocking	With mechanical interlocking
Control station colour	Yellow
Connections - terminals	Screw clamp terminals 1 x 0.5...2 x 1.5 mm ² with cable end Screw clamp terminals 1 x 0.5...1 x 2.5 mm ² without cable end
Standards	EN/IEC 60947-5-1 EN/IEC 60204-32 CSA C22.2 No 14 UL 508
Product certifications	CCC GOST
Protective treatment	TH
Ambient air temperature for operation	-25...70 °C
Ambient air temperature for storage	-40...70 °C
Vibration resistance	15 gn 10...500 Hz IEC 60068-2-6
Shock resistance	100 gn IEC 60068-2-27
Overvoltage category	Class II IEC 61140

Disclaimer: This documentation is not intended as a substitute for and is not to be used for determining suitability or reliability of these products for specific user applications

IP degree of protection	IP65 IEC 60529
IK degree of protection	IK08 EN 50102
Mechanical durability	1000000 cycles
Cable entry	Rubber sleeve with stepped entry 8...26 mm
Contact code designation	A600 AC-15 240 V 3 A IEC 60947-5-1 appendix A A600 AC-15 600 V 1.2 A IEC 60947-5-1 appendix A Q600 DC-13 250 V 0.27 A IEC 60947-5-1 appendix A Q600 DC-13 600 V 0.1 A IEC 60947-5-1 appendix A
[I _{th}] conventional enclosed thermal current	10 A
[U _i] rated insulation voltage	600 V 3
[U _{imp}] rated impulse withstand voltage	6 kV IEC 60947-1
Contacts operation	Slow-break
Resistance across terminals	<= 25 MOhm
Operating force	13 N push-button
Short circuit protection	10 A fuse protection cartridge gG
Rated operational power in W	40 W DC-13 1000000 cycles 60 cyc/mn 120 V 0.5 inductive IEC 60947-5-1 appendix C 48 W DC-13 1000000 cycles 60 cyc/mn 48 V 0.5 inductive IEC 60947-5-1 appendix C 65 W DC-13 1000000 cycles 60 cyc/mn 24 V 0.5 inductive IEC 60947-5-1 appendix C
Terminals description ISO n°1	(11-12)NC (13-14)NO
Terminal identifier	(13-14)NO (11-12)NC
Product weight	0.5 kg

Contractual warranty

Warranty period	18 months
-----------------	-----------

Dimensions

Below drawing shows a product with 6 cut-outs. Select the number of cut-outs according to the product characteristics in order to get b, b1 and c dimensions.

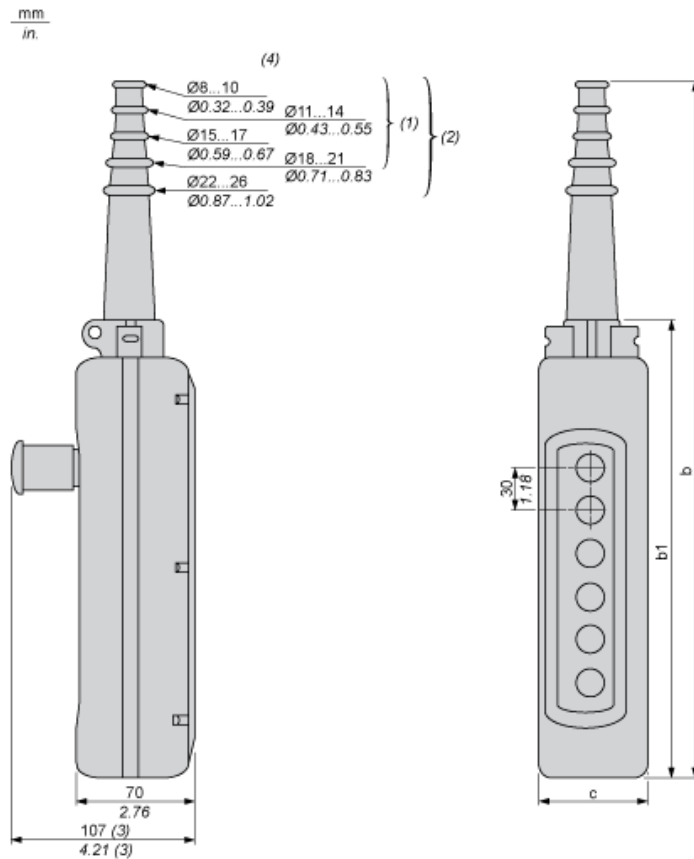

- (1) For 2 and 3-way XAC A stations.
- (2) For 4 to 8-way XAC A stations.
- (3) With trigger action Emergency stop head operator
- (4) Internal \varnothing

Dimensions in mm

Number of cut-outs	2	3	4	5	6	8	12
b	314	314	440	440	500	560	680
b1	190	190	250	250	310	370	490
c	80	80	80	80	80	80	92

Dimensions in in.

Number of cut-outs	2	3	4	5	6	8	12
b	12.36	12.36	17.32	17.32	19.68	22.05	26.77
b1	7.48	7.48	9.84	9.84	12.20	14.57	19.29
c	3.15	3.15	3.15	3.15	3.15	3.15	3.62

Control of Single-Speed Reversing Motor

With ZBE2BE101 + ZB2BE102 contacts blocks, to be ordered separately

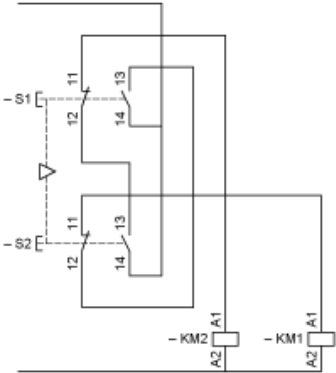

Rated Operational Power

AC Supply 50/60 Hz Inductive Circuit

Operating rate: 3600 operating cycles/hour. Load factor: 0.5.

Millions of operating cycles, AC-15 utilization category

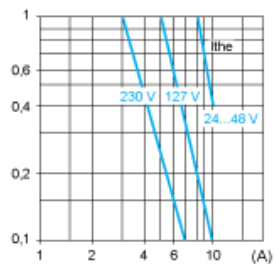

I_{the} Thermal current
(A) Current

DC Supply

Operating rate: 3600 operating cycles/hour. Load factor: 0.5.

Power broken in W for 1 million operating cycles, DC-13 utilization category

Voltage	V	24	48	120
Inductive circuit	W	65	48	40