

Boxes and Holders

Order code	Manufacturer code	Description
18-2965	n/a	2XAA PCB BATTERY HOLDER (RC)

Boxes and Holders	Page 1 of 2
The enclosed information is believed to be correct, Information may change without notice due to product improvement. Users should ensure that the product is suitable for their use. E. & O. E.	Revision A 20/02/2007

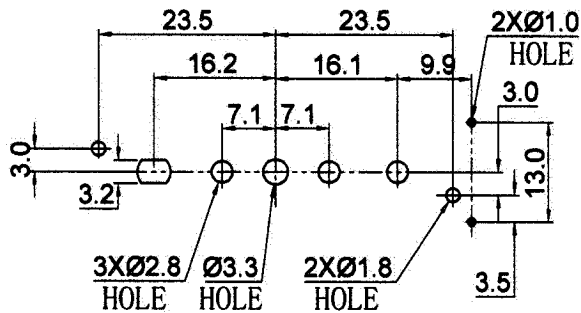

PCB/MOUNTING LAYOUT

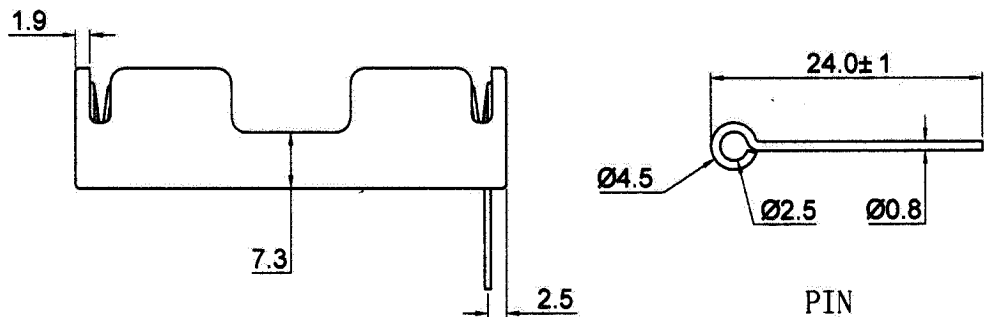
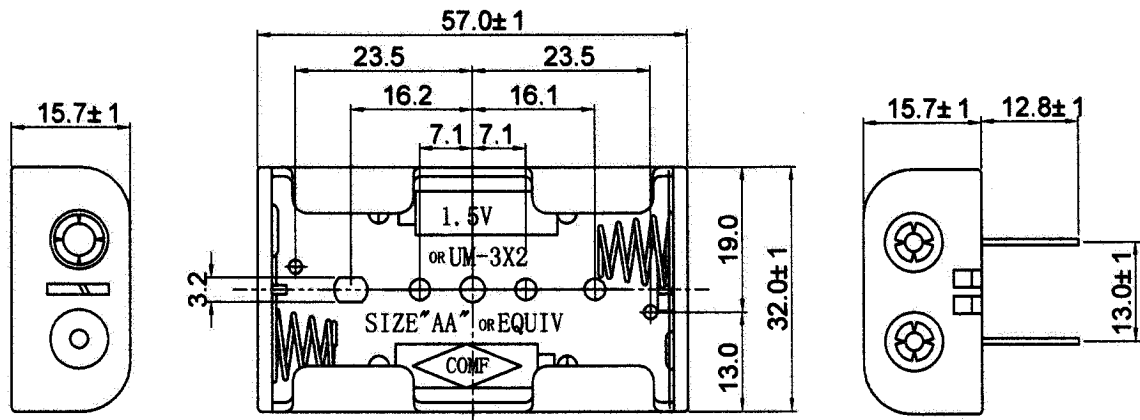

PIN

SPECIFICATION

- (1) ITEM NO: BH-321-1P₂₄
- (2) MATERIAL: P.P. RESIN, BLACK COLOR
- (3) WITH PIN: Ø0.8X24MM, BRASS NICKEL PLATED
- (4) SPRING: 0.6MM 65C SPRING STEEL
NICKEL PLATED
- (5) RIVET: BRASS NICKEL PLATED
- (6) RoHS COMPLIANT



3			COMFORTABLE ELECTRONIC CO.LTD.			
2						
1			NAME	BATTERY HOLDER :BH-321-1P ₂₄		
NO.	MODIFICATION	DATE	SCALE	1:1	APPD	<i>[Signature]</i> 29/30
			UNIT	MM	CHKD	<i>[Signature]</i> 30/30
			MAT'L	AS SPEC.	DWN	HUANGAILAN
			DATE	SEP. 30. 2008	DR NO	3211P ₂₄ -0908

