

LM3402/LM3402HV

0.5A Constant Current Buck Regulator for Driving High Power LEDs

General Description

The LM3402/02HV are monolithic switching regulators designed to deliver constant currents to high power LEDs. Ideal for automotive, industrial, and general lighting applications, they contain a high-side N-channel MOSFET switch with a current limit of 735 mA (typical) for step-down (Buck) regulators. Hysteretic control with controlled on-time coupled with an external resistor allow the converter output voltage to adjust as needed to deliver a constant current to series and series - parallel connected arrays of LEDs of varying number and type, LED dimming by pulse width modulation (PWM), broken/open LED protection, low-power shutdown and thermal shutdown complete the feature set.

Features

- Integrated 0.5A N-channel MOSFET
- V_{IN} Range from 6V to 42V (LM3402)
- V_{IN} Range from 6V to 75V (LM3402HV)
- 500 mA Output Current Over Temperature
- Cycle-by-Cycle Current Limit
- No Control Loop Compensation Required
- Separate PWM Dimming and Low Power Shutdown
- Supports all-ceramic output capacitors and capacitor-less outputs
- Thermal shutdown protection
- MSOP-8, PSOP-8 Packages

Applications

- LED Driver
- Constant Current Source
- Automotive Lighting
- General Illumination
- Industrial Lighting

Typical Application

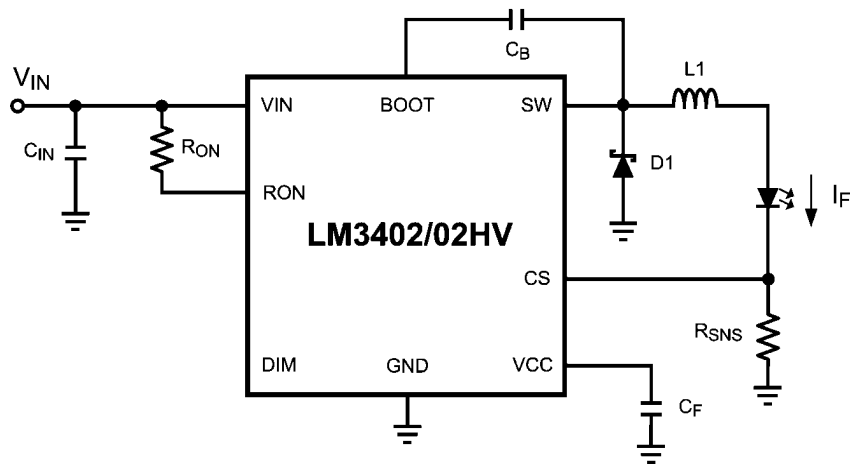

20192101

Connection Diagrams

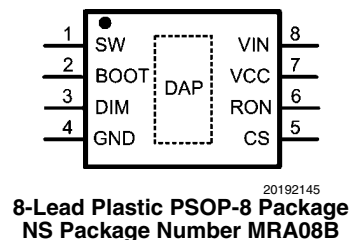
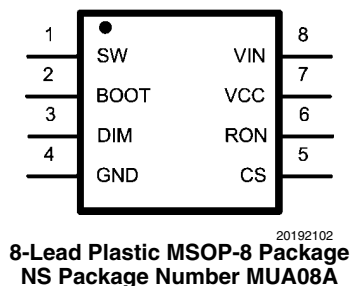

Ordering Information

Order Number	Package Type	NSC Package Drawing	Supplied As
LM3402MM	MSOP-8	MUA08A	1000 units on tape and reel
LM3402MMX			3500 units on tape and reel
LM3402HVMM			1000 units on tape and reel
LM3402HVMMX			3500 units on tape and reel
LM3402MR	PSOP-8	MRA08B	95 units in anti-static rails
LM3402MRX			2500 units on tape and reel
LM3402HVMR			95 units in anti-static rails
LM3402HVMRX			2500 units on tape and reel

Pin Descriptions

Pin(s)	Name	Description	Application Information
1	SW	Switch pin	Connect this pin to the output inductor and Schottky diode.
2	BOOT	MOSFET drive bootstrap pin	Connect a 10 nF ceramic capacitor from this pin to SW.
3	DIM	Input for PWM dimming	Connect a logic-level PWM signal to this pin to enable/disable the power FET and reduce the average light output of the LED array.
4	GND	Ground pin	Connect this pin to system ground.
5	CS	Current sense feedback pin	Set the current through the LED array by connecting a resistor from this pin to ground.
6	RON	On-time control pin	A resistor connected from this pin to VIN sets the regulator controlled on-time.
7	VCC	Output of the internal 7V linear regulator	Bypass this pin to ground with a minimum 0.1 μ F ceramic capacitor with X5R or X7R dielectric.
8	VIN	Input voltage pin	Nominal operating input range is 6V to 42V (LM3402) or 6V to 75V (LM3402HV).
DAP	GND	Thermal Pad	Connect to ground. Place 4 to 6 vias from DAP to bottom layer ground plane.

Absolute Maximum Ratings

(LM3402) (Note 1)

If Military/Aerospace specified devices are required, please contact the National Semiconductor Sales Office/ Distributors for availability and specifications.

VIN to GND	-0.3V to 45V
BOOT to GND	-0.3V to 59V
SW to GND	-1.5V
BOOT to VCC	-0.3V to 45V
BOOT to SW	-0.3V to 14V
VCC to GND	-0.3V to 14V
DIM to GND	-0.3V to 7V
CS to GND	-0.3V to 7V
RON to GND	-0.3V to 7V
Junction Temperature	150°C
Storage Temp. Range	-65°C to 125°C
ESD Rating (Note 2)	2kV
Soldering Information	
Lead Temperature (Soldering, 10sec)	260°C
Infrared/Convection Reflow (15sec)	235°C

Operating Ratings

(LM3402) (Note 1)

V_{IN}	6V to 42V
Junction Temperature Range	-40°C to +125°C
Thermal Resistance θ_{JA} (MSOP-8 Package) (Note 3)	200°C/W
Thermal Resistance θ_{JA} (PSOP-8 Package) (Note 5)	50°C/W

Absolute Maximum Ratings

(LM3402HV) (Note 1)

If Military/Aerospace specified devices are required, please contact the National Semiconductor Sales Office/Distributors for availability and specifications.

VIN to GND	-0.3V to 76V
BOOT to GND	-0.3V to 90V
SW to GND	-1.5V
BOOT to VCC	-0.3V to 76V
BOOT to SW	-0.3V to 14V
VCC to GND	-0.3V to 14V
DIM to GND	-0.3V to 7V
CS to GND	-0.3V to 7V
RON to GND	-0.3V to 7V
Junction Temperature	150°C

Storage Temp. Range	-65°C to 125°C
ESD Rating (Note 2)	2kV
Soldering Information	
Lead Temperature (Soldering, 10sec)	260°C
Infrared/Convection Reflow (15sec)	235°C

Operating Ratings

(LM3402HV) (Note 1)

V_{IN}	6V to 75V
Junction Temperature Range	-40°C to +125°C
Thermal Resistance θ_{JA} (MSOP-8 Package) (Note 3)	200°C/W
Thermal Resistance θ_{JA} (PSOP-8 Package) (Note 5)	50°C/W

Electrical Characteristics $V_{IN} = 24V$ unless otherwise indicated. Typicals and limits appearing in plain type apply for $T_A = T_J = +25^\circ C$. (Note 4) Limits appearing in boldface type apply over full Operating Temperature Range. Datasheet min/max specification limits are guaranteed by design, test, or statistical analysis.

LM3402

Symbol	Parameter	Conditions	Min	Typ	Max	Units
SYSTEM PARAMETERS						
t_{ON-1}	On-time 1	$V_{IN} = 10V, R_{ON} = 200 k\Omega$	2.1	2.75	3.4	μs
t_{ON-2}	On-time 2	$V_{IN} = 40V, R_{ON} = 200 k\Omega$	490	650	810	ns

LM3402HV

Symbol	Parameter	Conditions	Min	Typ	Max	Units
SYSTEM PARAMETERS						
t_{ON-1}	On-time 1	$V_{IN} = 10V, R_{ON} = 200 k\Omega$	2.1	2.75	3.4	μs
t_{ON-2}	On-time 2	$V_{IN} = 70V, R_{ON} = 200 k\Omega$	290	380	470	ns

LM3402/LM3402HV

Symbol	Parameter	Conditions	Min	Typ	Max	Units
REGULATION AND OVER-VOLTAGE COMPARATORS						
$V_{REF-REG}$	CS Regulation Threshold	CS Decreasing, SW turns on	194	200	206	mV
V_{REF-0V}	CS Over-voltage Threshold	CS Increasing, SW turns off		300		mV
I_{CS}	CS Bias Current	CS = 0V		0.1		μA
SHUTDOWN						
V_{SD-TH}	Shutdown Threshold	R_{ON} / SD Increasing	0.3	0.7	1.05	V
V_{SD-HYS}	Shutdown Hysteresis	R_{ON} / SD Decreasing		40		mV
OFF TIMER						
$t_{OFF-MIN}$	Minimum Off-time	CS = 0V		300		ns
INTERNAL REGULATOR						
V_{CC-REG}	V_{CC} Regulated Output		6.6	7	7.4	V
V_{IN-DO}	$V_{IN} - V_{CC}$ Dropout	$I_{CC} = 5 mA, 6.0V < V_{IN} < 8.0V$		300		mV
$V_{CC-BP-TH}$	V_{CC} Bypass Threshold	V_{IN} Increasing		8.8		V
$V_{CC-BP-HYS}$	V_{CC} Bypass Hysteresis	V_{IN} Decreasing		225		mV
V_{CC-Z-6}	V_{CC} Output Impedance (0 mA < I_{CC} < 5 mA)	$V_{IN} = 6V$		55		Ω
V_{CC-Z-8}		$V_{IN} = 8V$		50		
$V_{CC-Z-24}$		$V_{IN} = 24V$		0.4		
V_{CC-LIM}	V_{CC} Current Limit (Note 3)	$V_{IN} = 24V, V_{CC} = 0V$		16		mA
$V_{CC-UV-TH}$	V_{CC} Under-voltage Lock-out Threshold	V_{CC} Increasing		5.25		V
$V_{CC-UV-HYS}$	V_{CC} Under-voltage Lock-out Hysteresis	V_{CC} Decreasing		150		mV
$V_{CC-UV-DLY}$	V_{CC} Under-voltage Lock-out Filter Delay	100 mV Overdrive		3		μs
I_{IN-OP}	I_{IN} Operating Current	Non-switching, CS = 0V		600	900	μA
I_{IN-SD}	I_{IN} Shutdown Current	$R_{ON} / SD = 0V$		90	180	μA
CURRENT LIMIT						
I_{LIM}	Current Limit Threshold		530	735	940	mA
DIM COMPARATOR						
V_{IH}	Logic High	DIM Increasing	2.2			V
V_{IL}	Logic Low	DIM Decreasing			0.8	V

Symbol	Parameter	Conditions	Min	Typ	Max	Units
I_{DIM-PU}	DIM Pull-up Current	DIM = 1.5V		75		μA
N-MOSFET AND DRIVER						
R_{DS-ON}	Buck Switch On Resistance	$I_{SW} = 200mA$, BOOT-SW = 6.3V		0.7	1.5	Ω
$V_{DR-UVLO}$	BOOT Under-voltage Lock-out Threshold	BOOT-SW Increasing	1.7	3	4	V
V_{DR-HYS}	BOOT Under-voltage Lock-out Hysteresis	BOOT-SW Decreasing		400		mV
THERMAL SHUTDOWN						
T_{SD}	Thermal Shutdown Threshold			165		$^{\circ}C$
T_{SD-HYS}	Thermal Shutdown Hysteresis			25		$^{\circ}C$
THERMAL RESISTANCE						
θ_{JA}	Junction to Ambient	MSOP-8 Package		200		$^{\circ}C/W$
		PSOP-8 Package		50		

Note 1: Absolute Maximum Ratings indicate limits beyond which damage to the device may occur. Operating Ratings indicate conditions for which the device is intended to be functional, but specific performance is not guaranteed. For guaranteed specifications and the test conditions, see Electrical Characteristics.

Note 2: The human body model is a 100 pF capacitor discharged through a 1.5 k Ω resistor into each pin.

Note 3: VCC provides self bias for the internal gate drive and control circuits. Device thermal limitations limit external loading.

Note 4: Typical specifications represent the most likely parametric norm at 25 $^{\circ}C$ operation.

Note 5: θ_{JA} of 50 $^{\circ}C/W$ with DAP soldered to a minimum of 2 square inches of 1 oz. copper on the top or bottom PCB layer.

Typical Performance Characteristics

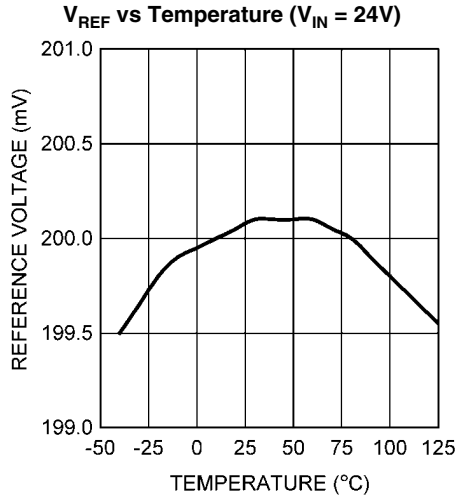

20192129

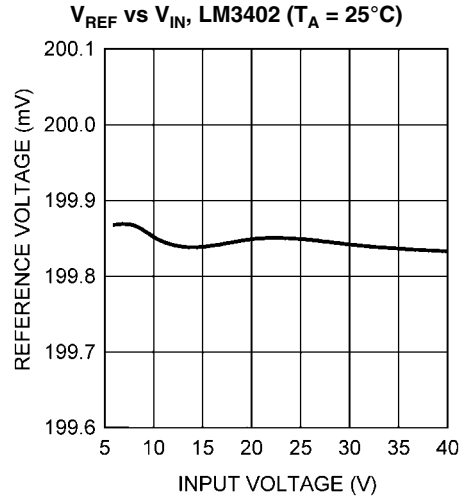

20192130

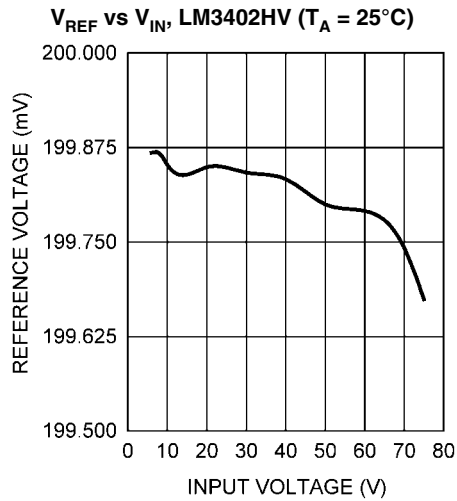

20192131

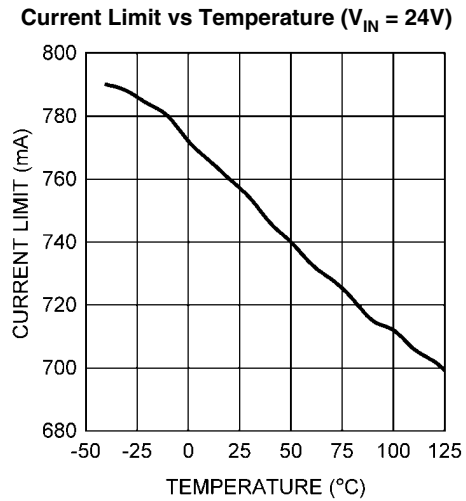

20192132

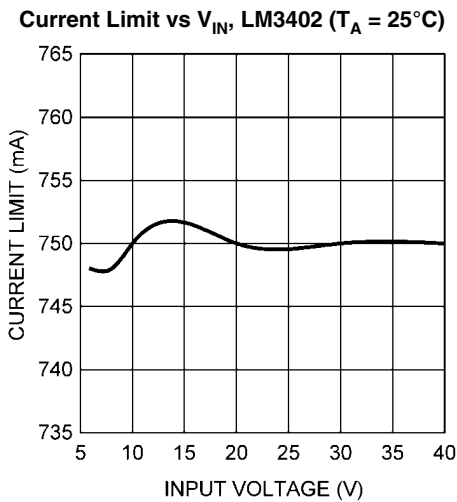

20192133

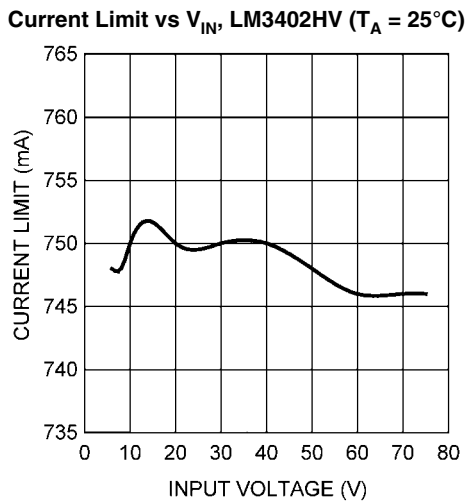

20192134

**T_{ON} vs V_{IN} ,
 $R_{ON} = 100\text{ k}\Omega$ ($T_A = 25^\circ\text{C}$)**

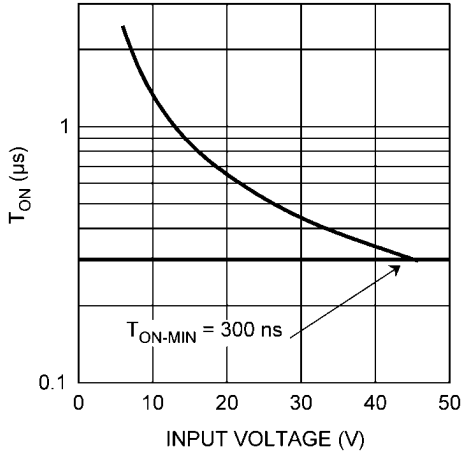

20192135

**T_{ON} vs V_{IN} ,
($T_A = 25^\circ\text{C}$)**

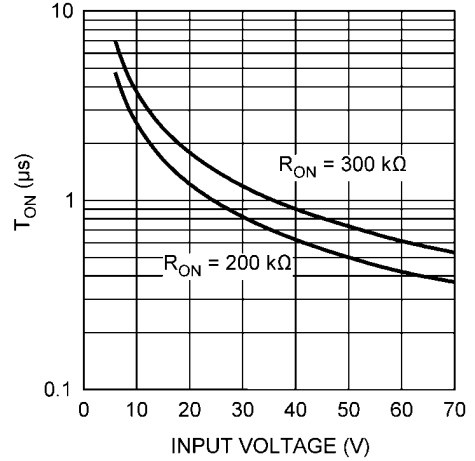

20192136

**T_{ON} vs V_{IN} ,
($T_A = 25^\circ\text{C}$)**

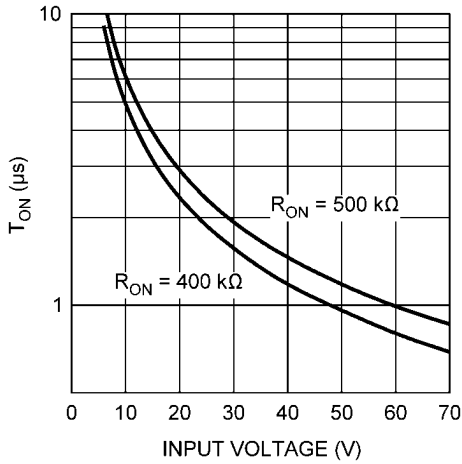

20192137

**T_{ON} vs R_{ON} , LM3402
($T_A = 25^\circ\text{C}$)**

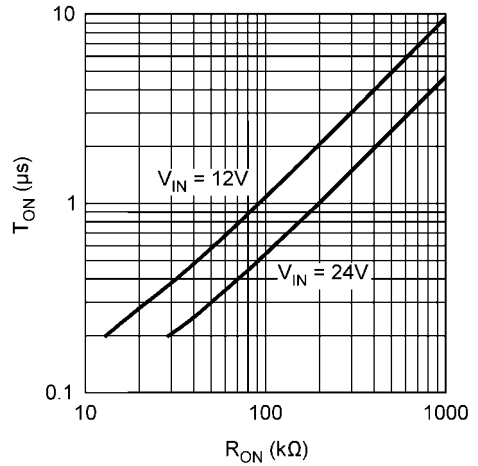

20192144

**T_{ON} vs R_{ON} , LM3402HV
($T_A = 25^\circ\text{C}$)**

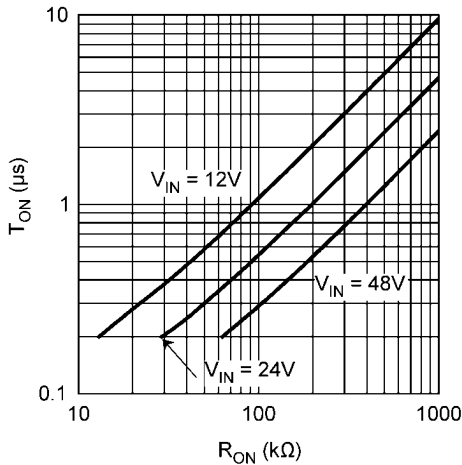

20192138

**V_{CC} vs V_{IN}
($T_A = 25^\circ\text{C}$)**

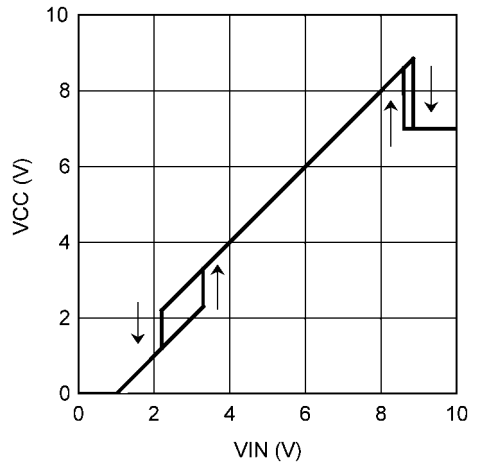

20192139

V_{O-MAX} vs f_{SW} , LM3402
($T_A = 25^\circ\text{C}$)

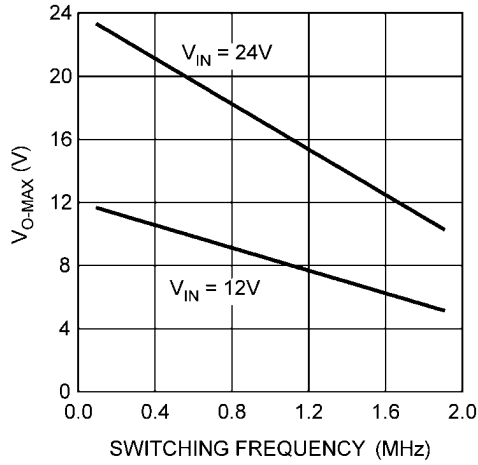

20192140

V_{O-MIN} vs f_{SW} , LM3402
($T_A = 25^\circ\text{C}$)

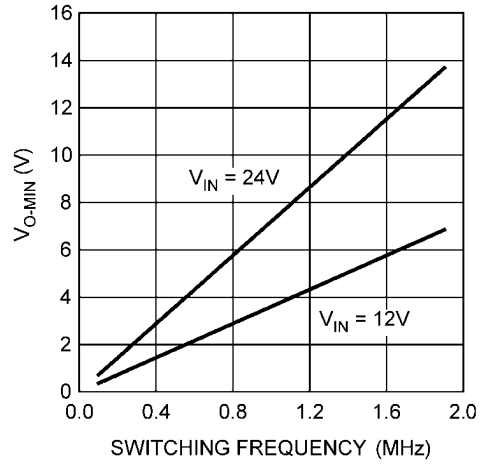

20192141

V_{O-MAX} vs f_{SW} , LM3402HV
($T_A = 25^\circ\text{C}$)

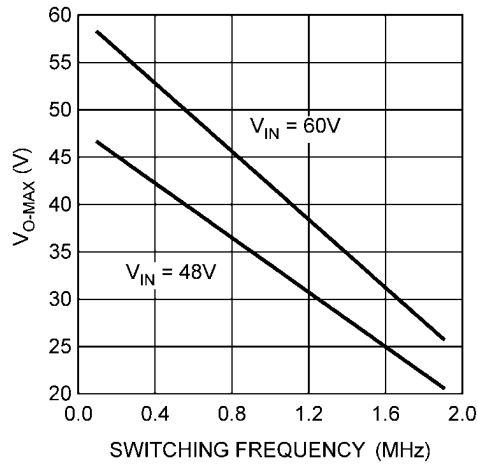

20192142

V_{O-MIN} vs f_{SW} , LM3402HV
($T_A = 25^\circ\text{C}$)

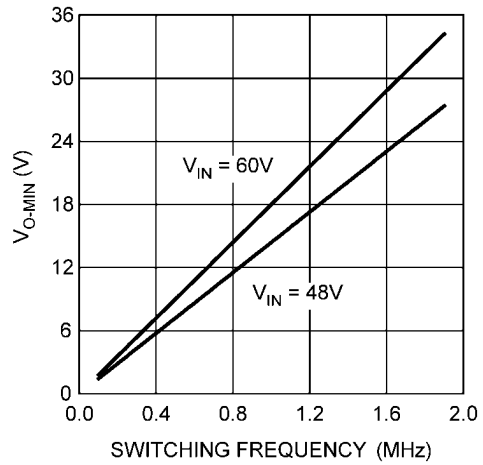

20192143

Block Diagram

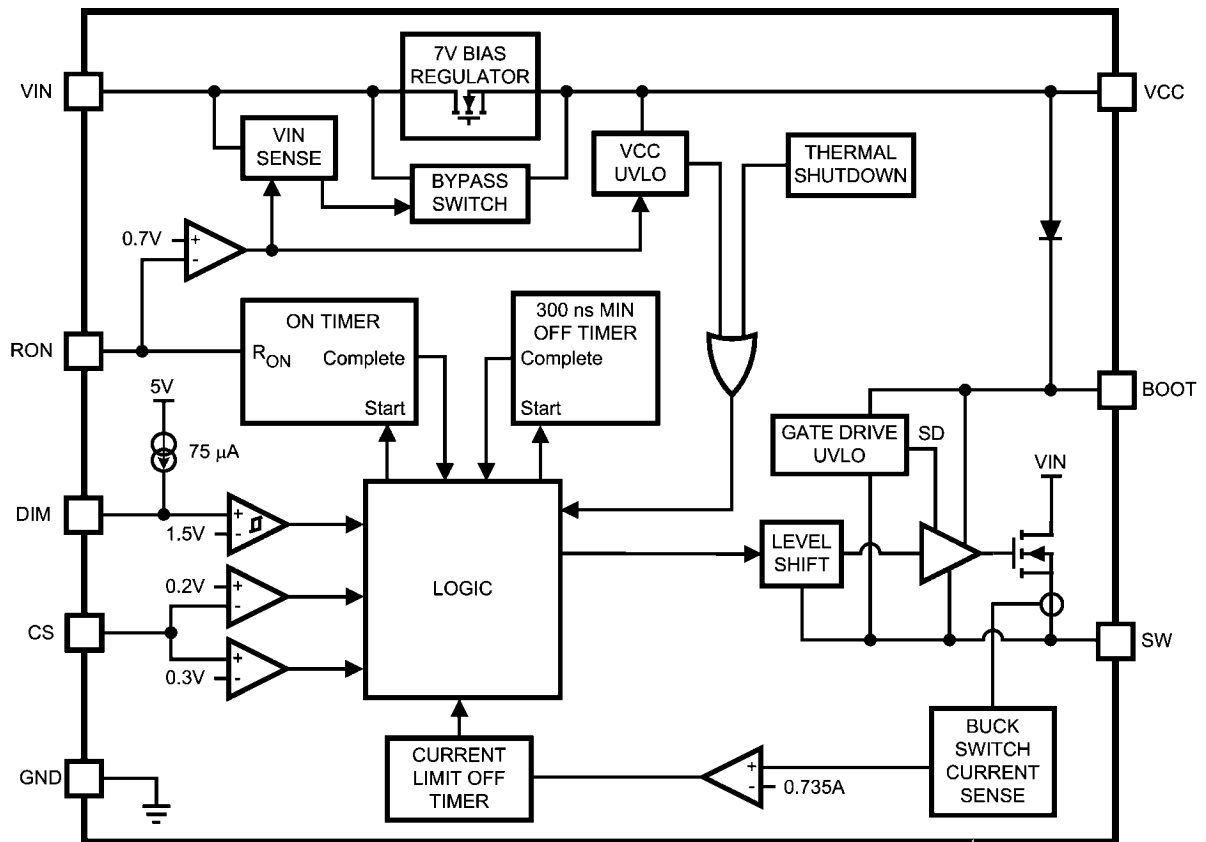

20192103

Application Information

THEORY OF OPERATION

The LM3402 and LM3402HV are buck regulators with a wide input voltage range, low voltage reference, and a fast output enable/disable function. These features combine to make them ideal for use as a constant current source for LEDs with forward currents as high as 500 mA. The controlled on-time (COT) architecture is a combination of hysteretic mode control and a one-shot on-timer that varies inversely with input voltage. Hysteretic operation eliminates the need for small-signal control loop compensation. When the converter runs in continuous conduction mode (CCM) the controlled on-time maintains a constant switching frequency over the range of input voltage. Fast transient response, PWM dimming, a low power shutdown mode, and simple output overvoltage protection round out the functions of the LM3402/02HV.

CONTROLLED ON-TIME OVERVIEW

Figure 1 shows the feedback system used to control the current through an array of LEDs. A voltage signal, V_{SNS} , is

created as the LED current flows through the current setting resistor, R_{SNS} , to ground. V_{SNS} is fed back to the CS pin, where it is compared against a 200 mV reference, V_{REF} . The on-comparator turns on the power MOSFET when V_{SNS} falls below V_{REF} . The power MOSFET conducts for a controlled on-time, t_{ON} , set by an external resistor, R_{ON} , and by the input voltage, V_{IN} . On-time is governed by the following equation:

$$t_{ON} = 1.34 \times 10^{-10} \times \frac{R_{ON}}{V_{IN}}$$

At the conclusion of t_{ON} the power MOSFET turns off for a minimum off-time, $t_{OFF-MIN}$, of 300 ns. Once $t_{OFF-MIN}$ is complete the CS comparator compares V_{SNS} and V_{REF} again, waiting to begin the next cycle.

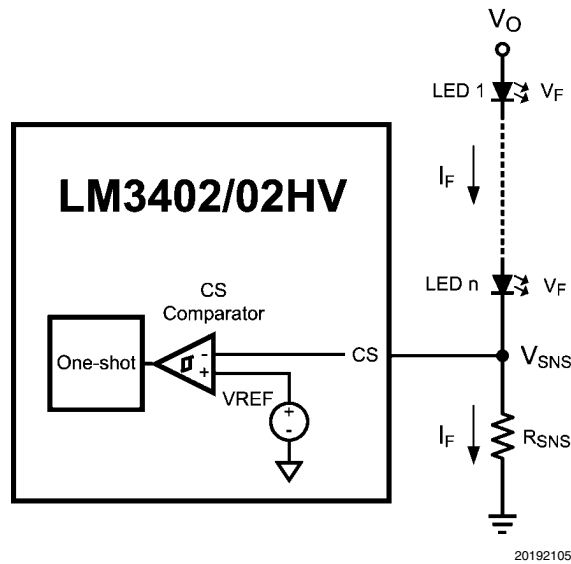

FIGURE 1. Comparator and One-Shot

The LM3402/02HV regulators should be operated in continuous conduction mode (CCM), where inductor current stays positive throughout the switching cycle. During steady-state operation in the CCM, the converter maintains a constant switching frequency, which can be selected using the following equation:

$$f_{SW} = \frac{V_O}{1.34 \times 10^{-10} \times R_{ON}}$$

$$V_O = n \times V_F + 200 \text{ mV}$$

V_F = forward voltage of each LED, n = number of LEDs in series

AVERAGE LED CURRENT ACCURACY

The COT architecture regulates the valley of ΔV_{SNS} , the AC portion of V_{SNS} . To determine the average LED current (which is also the average inductor current) the valley inductor current is calculated using the following expression:

$$I_{L-MIN} = \frac{0.2}{R_{SNS}} - \frac{V_O \times t_{SNS}}{L}$$

In this equation t_{SNS} represents the propagation delay of the CS comparator, and is approximately 220 ns. The average inductor/LED current is equal to I_{L-MIN} plus one-half of the inductor current ripple, ΔI_L :

$$I_F = I_L = I_{L-MIN} + \Delta I_L / 2$$

Detailed information for the calculation of ΔI_L is given in the Design Considerations section.

MAXIMUM OUTPUT VOLTAGE

The 300 ns minimum off-time limits on the maximum duty cycle of the converter, D_{MAX} , and in turn, the maximum output voltage $V_{O(MAX)}$ is determined by the following equations:

$$D_{MAX} = \frac{t_{ON}}{t_{ON} + t_{OFF-MIN}}$$

$$V_{O(max)} = D_{MAX} \times V_{IN}$$

The maximum number of LEDs, n_{MAX} , that can be placed in a single series string is governed by $V_{O(MAX)}$ and the maximum forward voltage of the LEDs used, $V_{F(MAX)}$, using the expression:

$$n_{MAX} = \frac{V_{O(max)} - 200 \text{ mV}}{V_{F(MAX)}}$$

At low switching frequency the maximum duty cycle and output voltage are higher, allowing the LM3402/02HV to regulate output voltages that are nearly equal to input voltage. The following equation relates switching frequency to maximum output voltage.

$$V_{O(MAX)} = V_{IN} \times \frac{T_{SW} - 300 \text{ ns}}{T_{SW}}$$

$$T_{SW} = 1/f_{SW}$$

MINIMUM OUTPUT VOLTAGE

The minimum recommended on-time for the LM3402/02HV is 300 ns. This lower limit for t_{ON} determines the minimum duty cycle and output voltage that can be regulated based on input voltage and switching frequency. The relationship is determined by the following equation:

$$V_{O(MIN)} = V_{IN} \times \frac{300 \text{ ns}}{T_{SW}}$$

HIGH VOLTAGE BIAS REGULATOR

The LM3402/02HV contains an internal linear regulator with a 7V output, connected between the VIN and the VCC pins. The VCC pin should be bypassed to the GND pin with a 0.1 μ F ceramic capacitor connected as close as possible to the pins of the IC. VCC tracks VIN until VIN reaches 8.8V (typical) and then regulates at 7V as VIN increases. Operation begins when VCC crosses 5.25V.

INTERNAL MOSFET AND DRIVER

The LM3402/02HV features an internal power MOSFET as well as a floating driver connected from the SW pin to the BOOT pin. Both rise time and fall time are 20 ns each (typical) and the approximate gate charge is 3 nC. The high-side rail for the driver circuitry uses a bootstrap circuit consisting of an internal high-voltage diode and an external 10 nF capacitor, C_B . V_{CC} charges C_B through the internal diode while the power MOSFET is off. When the MOSFET turns on, the internal diode reverse biases. This creates a floating supply equal to the V_{CC} voltage minus the diode drop to drive the MOSFET when its source voltage is equal to V_{IN} .

FAST SHUTDOWN FOR PWM DIMMING

The DIM pin of the LM3402/02HV is a TTL logic compatible input for low frequency PWM dimming of the LED. A logic low (below 0.8V) at DIM will disable the internal MOSFET and shut off the current flow to the LED array. While the DIM pin is in a logic low state the support circuitry (driver, bandgap, VCC) remains active in order to minimize the time needed to turn the LED array back on when the DIM pin sees a logic high (above 2.2V). A 75 μ A (typical) pull-up current ensures that the LM3402/02HV is on when DIM pin is open circuited, eliminating the need for a pull-up resistor. Dimming frequency, f_{DIM} , and duty cycle, D_{DIM} , are limited by the LED current rise time and fall time and the delay from activation of the DIM pin to the response of the internal power MOSFET. In general, f_{DIM} should be at least one order of magnitude lower than the steady state switching frequency in order to prevent aliasing.

PEAK CURRENT LIMIT

The current limit comparator of the LM3402/02HV will engage whenever the power MOSFET current (equal to the inductor

current while the MOSFET is on) exceeds 735 mA (typical). The power MOSFET is disabled for a cool-down time that is 10x the steady-state on-time. At the conclusion of this cool-down time the system re-starts. If the current limit condition persists the cycle of cool-down time and restarting will continue, creating a low-power hiccup mode, minimizing thermal stress on the LM3402/02HV and the external circuit components.

OVER-VOLTAGE/OVER-CURRENT COMPARATOR

The CS pin includes an output over-voltage/over-current comparator that will disable the power MOSFET whenever V_{SNS} exceeds 300 mV. This threshold provides a hard limit for the output current. Output current overshoot is limited to $300 \text{ mV} / R_{SNS}$ by this comparator during transients.

The OVP/OCP comparator can also be used to prevent the output voltage from rising to $V_{O(MAX)}$ in the event of an output open-circuit. This is the most common failure mode for LEDs, due to breaking of the bond wires. In a current regulator an output open circuit causes V_{SNS} to fall to zero, commanding maximum duty cycle. Figure 2 shows a method using a zener diode, Z1, and zener limiting resistor, R_Z , to limit output voltage to the reverse breakdown voltage of Z1 plus 200 mV. The zener diode reverse breakdown voltage, V_Z , must be greater than the maximum combined V_F of all LEDs in the array. The maximum recommended value for R_Z is 1 k Ω .

As discussed in the Maximum Output Voltage section, there is a limit to how high V_O can rise during an output open-circuit that is always less than V_{IN} . If no output capacitor is used, the output stage of the LM3402/02HV is capable of withstanding $V_{O(MAX)}$ indefinitely, however the voltage at the output end of the inductor will oscillate and can go above V_{IN} or below 0V. A small (typically 10 nF) capacitor across the LED array dampens this oscillation. For circuits that use an output capacitor, the system can still withstand $V_{O(MAX)}$ indefinitely as long as C_O is rated to handle V_{IN} . The high current paths are blocked in output open-circuit and the risk of thermal stress is minimal, hence the user may opt to allow the output voltage to rise in the case of an open-circuit LED failure.

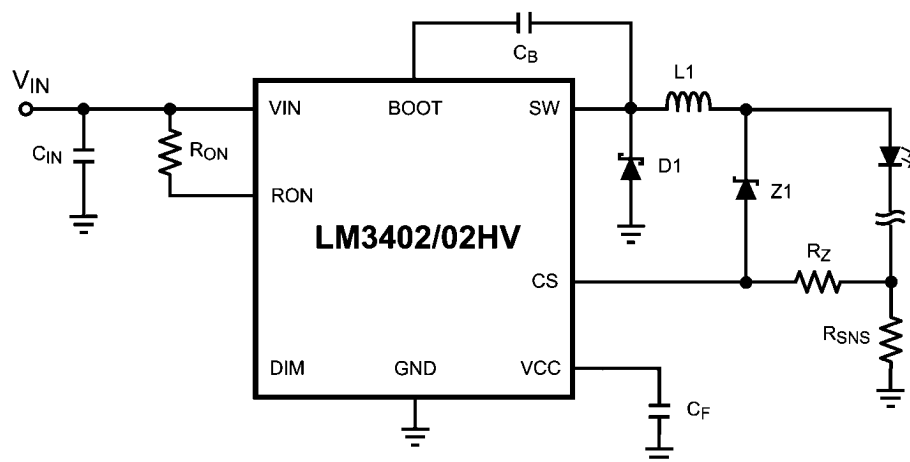

20192112

FIGURE 2. Output Open Circuit Protection

LOW POWER SHUTDOWN

The LM3402/02HV can be switched to a low power state ($I_{IN-SD} = 90 \mu A$) by grounding the RON pin with a signal-level MOSFET as shown in Figure 3. Low power MOSFETs like the 2N7000, 2N3904, or equivalent are recommended devices for putting the LM3402/02HV into low power shutdown. Logic gates can also be used to shut down the LM3402/02HV as

long as the logic low voltage is below the over temperature minimum threshold of 0.3V. Noise filter circuitry on the RON pin can cause a few pulses with a longer on-time than normal after RON is grounded or released. In these cases the OVP/OCP comparator will ensure that the peak inductor or LED current does not exceed $300 \text{ mV} / R_{SNS}$.

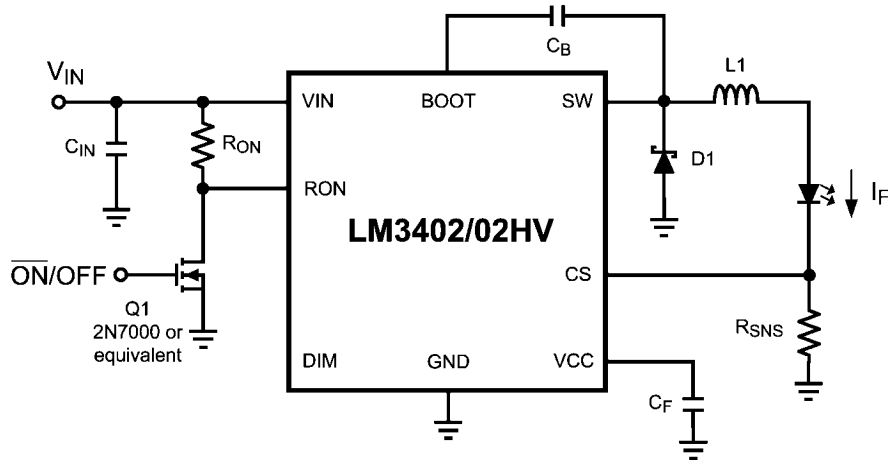

20192113

FIGURE 3. Low Power Shutdown

THERMAL SHUTDOWN

Internal thermal shutdown circuitry is provided to protect the IC in the event that the maximum junction temperature is ex-

ceeded. The threshold for thermal shutdown is 165°C with a 25°C hysteresis (both values typical). During thermal shutdown the MOSFET and driver are disabled.

Design Considerations

SWITCHING FREQUENCY

Switching frequency is selected based on the tradeoffs between efficiency (better at low frequency), solution size/cost (smaller at high frequency), and the range of output voltage that can be regulated (wider at lower frequency.) Many applications place limits on switching frequency due to EMI sensitivity. The on-time of the LM3402/02HV can be programmed for switching frequencies ranging from the 10's of kHz to over 1 MHz. The maximum switching frequency is limited only by the minimum on-time requirement.

LED RIPPLE CURRENT

Selection of the ripple current, Δi_F , through the LED array is analogous to the selection of output ripple voltage in a standard voltage regulator. Where the output ripple in a voltage regulator is commonly $\pm 1\%$ to $\pm 5\%$ of the DC output voltage, LED manufacturers generally recommend values for Δi_F ranging from $\pm 5\%$ to $\pm 20\%$ of I_F . Higher LED ripple current allows the use of smaller inductors, smaller output capacitors, or no output capacitors at all. The advantages of higher ripple current are reduction in the solution size and cost. Lower ripple current requires more output inductance, higher switching frequency, or additional output capacitance. The advantages of lower ripple current are a reduction in heating in the LED itself and greater range of the average LED current before the current limit of the LED or the driving circuitry is reached.

BUCK CONVERTERS WITHOUT OUTPUT CAPACITORS

The buck converter is unique among non-isolated topologies because of the direct connection of the inductor to the load during the entire switching cycle. By definition an inductor will control the rate of change of current that flows through it, and this control over current ripple forms the basis for component selection in both voltage regulators and current regulators. A current regulator such as the LED driver for which the LM3402/02HV was designed focuses on the control of the current through the load, not the voltage across it. A constant current regulator is free of load current transients, and has no need of output capacitance to supply the load and maintain output voltage. Referring to the Typical Application circuit on the front page of this datasheet, the inductor and LED can form a single series chain, sharing the same current. When no output capacitor is used, the same equations that govern inductor ripple current, Δi_L , also apply to the LED ripple current, Δi_F . For a controlled on-time converter such as LM3402/02HV the ripple current is described by the following expression:

$$\Delta i_L = \Delta i_F = \frac{V_{IN} - V_O}{L} t_{ON}$$

A minimum ripple voltage of 25 mV is recommended at the CS pin to provide good signal-to-noise ratio (SNR). The CS pin ripple voltage, ΔV_{SNS} , is described by the following:

$$\Delta V_{SNS} = \Delta i_F \times R_{SNS}$$

BUCK CONVERTERS WITH OUTPUT CAPACITORS

A capacitor placed in parallel with the LED or array of LEDs can be used to reduce the LED current ripple while keeping the same average current through both the inductor and the LED array. This technique is demonstrated in Design Example 1. With this topology the output inductance can be low-

ered, making the magnetics smaller and less expensive. Alternatively, the circuit could be run at lower frequency but keep the same inductor value, improving the efficiency and expanding the range of output voltage that can be regulated. Both the peak current limit and the OVP/OCP comparator still monitor peak inductor current, placing a limit on how large Δi_L can be even if Δi_F is made very small. A parallel output capacitor is also useful in applications where the inductor or input voltage tolerance is poor. Adding a capacitor that reduces Δi_F to well below the target provides headroom for changes in inductance or V_{IN} that might otherwise push the peak LED ripple current too high.

Figure 4 shows the equivalent impedances presented to the inductor current ripple when an output capacitor, C_O , and its equivalent series resistance (ESR) are placed in parallel with the LED array. The entire inductor ripple current flows through R_{SNS} to provide the required 25 mV of ripple voltage for proper operation of the CS comparator.

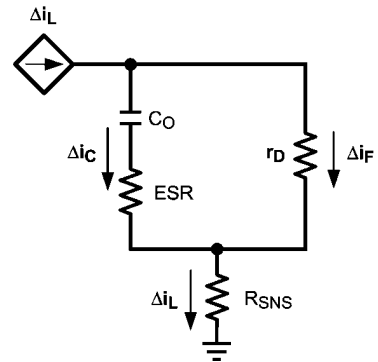

20192115

FIGURE 4. LED and C_O Ripple Current

To calculate the respective ripple currents the LED array is represented as a dynamic resistance, r_D . LED dynamic resistance is not always specified on the manufacturer's datasheet, but it can be calculated as the inverse slope of the LED's V_F vs. I_F curve. Note that dividing V_F by I_F will give an incorrect value that is 5x to 10x too high. Total dynamic resistance for a string of n LEDs connected in series can be calculated as the r_D of one device multiplied by n . Inductor ripple current is still calculated with the expression from Buck Regulators without Output Capacitors. The following equations can then be used to estimate Δi_F when using a parallel capacitor:

$$\Delta i_F = \frac{\Delta i_L}{1 + \frac{r_D}{Z_C}}$$

$$Z_C = ESR + \frac{1}{2\pi \times f_{SW} \times C_O}$$

The calculation for Z_C assumes that the shape of the inductor ripple current is approximately sinusoidal.

Small values of C_O that do not significantly reduce Δi_F can also be used to control EMI generated by the switching action of the LM3402/02HV. EMI reduction becomes more important as the length of the connections between the LED and the rest of the circuit increase.

INPUT CAPACITORS

Input capacitors at the VIN pin of the LM3402/02HV are selected using requirements for minimum capacitance and rms ripple current. The input capacitors supply pulses of current approximately equal to I_F while the power MOSFET is on, and are charged up by the input voltage while the power MOSFET is off. Switching converters such as the LM3402/02HV have a negative input impedance due to the decrease in input current as input voltage increases. This inverse proportionality of input current to input voltage can cause oscillations (sometimes called 'power supply interaction') if the magnitude of the negative input impedance is greater than the input filter impedance. Minimum capacitance can be selected by comparing the input impedance to the converter's negative resistance; however this requires accurate calculation of the input voltage source inductance and resistance, quantities which can be difficult to determine. An alternative method to select the minimum input capacitance, $C_{IN(MIN)}$, is to select the maximum voltage ripple which can be tolerated. This value, $\Delta V_{IN(MAX)}$, is equal to the change in voltage across C_{IN} during the converter on-time, when C_{IN} supplies the load current. $C_{IN(MIN)}$ can be selected with the following:

$$C_{IN(MIN)} = \frac{I_F \times t_{ON}}{\Delta V_{IN(MAX)}}$$

A good starting point for selection of C_{IN} is to use an input voltage ripple of 5% to 10% of V_{IN} . A minimum input capacitance of 2x the $C_{IN(MIN)}$ value is recommended for all LM3402/02HV circuits. To determine the rms current rating, the following formula can be used:

$$I_{IN(rms)} = I_F \times \sqrt{D(1 - D)}$$

Ceramic capacitors are the best choice for the input to the LM3402/02HV due to their high ripple current rating, low ESR, low cost, and small size compared to other types. When selecting a ceramic capacitor, special attention must be paid to the operating conditions of the application. Ceramic capacitors can lose one-half or more of their capacitance at their rated DC voltage bias and also lose capacitance with extremes in temperature. A DC voltage rating equal to twice the expected maximum input voltage is recommended. In addition, the minimum quality dielectric which is suitable for switching power supply inputs is X5R, while X7R or better is preferred.

RECIRCULATING DIODE

The LM3402/02HV is a non-synchronous buck regulator that requires a recirculating diode D1 (see the Typical Application circuit) to carry the inductor current during the MOSFET off-time. The most efficient choice for D1 is a Schottky diode due to low forward drop and near-zero reverse recovery time. D1 must be rated to handle the maximum input voltage plus any switching node ringing when the MOSFET is on. In practice all switching converters have some ringing at the switching node due to the diode parasitic capacitance and the lead inductance. D1 must also be rated to handle the average current, I_D , calculated as:

$$I_D = (1 - D) \times I_F$$

This calculation should be done at the maximum expected input voltage. The overall converter efficiency becomes more dependent on the selection of D1 at low duty cycles, where the recirculating diode carries the load current for an increasing percentage of the time. This power dissipation can be calculated by checking the typical diode forward voltage, V_D , from the I-V curve on the product datasheet and then multiplying it by I_D . Diode datasheets will also provide a typical junction-to-ambient thermal resistance, θ_{JA} , which can be used to estimate the operating die temperature of the Schottky. Multiplying the power dissipation ($P_D = I_D \times V_D$) by θ_{JA} gives the temperature rise. The diode case size can then be selected to maintain the Schottky diode temperature below the operational maximum.

Design Example 1: LM3402

The first example circuit will guide the user through component selection for an architectural accent lighting application. A regulated DC voltage input of $24V \pm 10\%$ will power a single 1W white LED at a forward current of $350\text{ mA} \pm 5\%$. The typical forward voltage of a 1W InGaN LED is 3.5V, hence the estimated average output voltage will be 3.7V. The objective of this application is to place the complete current regulator and LED in the compact space formerly occupied by an MR16 halogen light bulb. (The LED will be on a separate metal-core PCB.) Switching frequency will be as fast as the 300 ns t_{ON} limit allows, with the emphasis on space savings over efficiency. Efficiency cannot be ignored, however, as the confined space with little air-flow requires a maximum temperature rise of 40°C in each circuit component. A complete bill of materials can be found in Table 1 at the end of this datasheet.

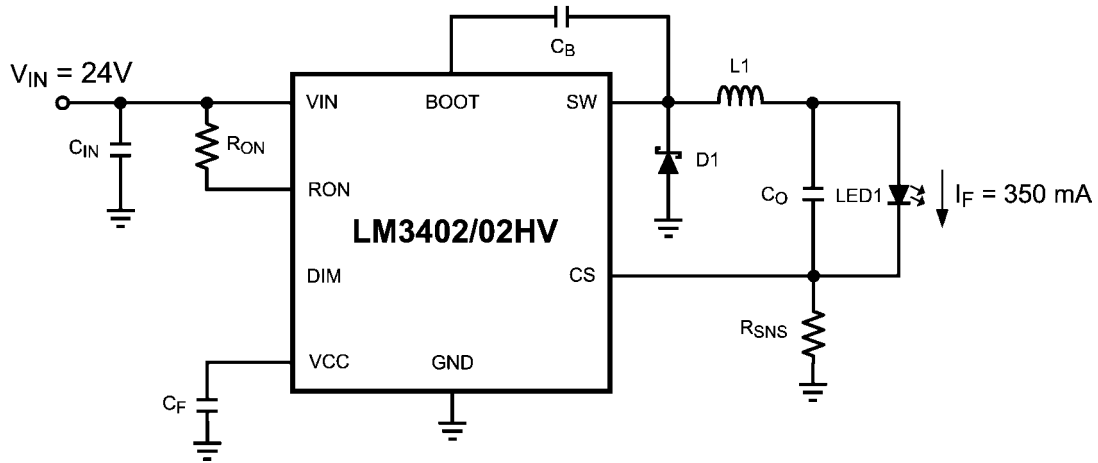

20192119

FIGURE 5. Schematic for Design Example 1

R_{ON} and t_{ON}

To select R_{ON} the expression relating t_{ON} to input voltage from the Controlled On-time Overview section can be re-written as:

$$R_{ON} = \frac{t_{ON} \times V_{IN}}{1.34 \times 10^{-10}}$$

Minimum on-time occurs at the maximum V_{IN}, which is 24V x 110% = 26.4V. R_{ON} is therefore calculated as:

$$R_{ON} = (300 \times 10^{-9} \times 26.4) / 1.34 \times 10^{-10} = 59105 \Omega$$

The closest 1% tolerance resistor is 59.0 kΩ. The switching frequency of the circuit can then be found using the equation relating R_{ON} to f_{SW}:

$$f_{SW} = 3.7 / (59000 \times 1.34 \times 10^{-10}) = 468 \text{ kHz}$$

USING AN OUTPUT CAPACITOR

The inductor will be the largest component used in this design. Because the application does not require any PWM dimming, an output capacitor can be used to greatly reduce the inductance needed without worry of slowing the potential PWM dimming frequency. The total solution size will be reduced by using an output capacitor and small inductor as opposed to one large inductor.

OUTPUT INDUCTOR

Knowing that an output capacitor will be used, the inductor can be selected for a larger current ripple. The desired maximum value for Δi_L is ±30%, or 0.6 x 350 mA = 210 mA_{P-P}. Minimum inductance is selected at the maximum input voltage. Re-arranging the equation for current ripple selection yields the following:

$$L_{MIN} = \frac{V_{IN(MAX)} - V_O}{\Delta i_L} \times t_{ON}$$

$$L_{MIN} = [(26.4 - 3.7) \times 300 \times 10^{-9}] / (0.6 \times 0.35) = 32.4 \mu\text{H}$$

The closest standard inductor value is 33 μH. Off-the-shelf inductors rated at 33 μH are available from many magnetics manufacturers.

Inductor datasheets should contain three specifications which are used to select the inductor. The first of these is the average current rating, which for a buck regulator is equal to the average load current, or I_F. The average current rating is given by a specified temperature rise in the inductor, normally 40° C. For this example, the average current rating should be greater than 350 mA to ensure that heat from the inductor does not reduce the lifetime of the LED or cause the LM3402 to enter thermal shutdown.

The second specification is the tolerance of the inductance itself, typically ±10% to ±30% of the rated inductance. In this example an inductor with a tolerance of ±20% will be used. With this tolerance the typical, minimum, and maximum inductor current ripples can be calculated:

$$\Delta i_{L(TYP)} = [(26.4 - 3.7) \times 300 \times 10^{-9}] / 33 \times 10^{-6} = 206 \text{ mA}_{P-P}$$

$$\Delta i_{L(MIN)} = [(26.4 - 3.7) \times 300 \times 10^{-9}] / 39.6 \times 10^{-6} = 172 \text{ mA}_{P-P}$$

$$\Delta i_{L(MAX)} = [(26.4 - 3.7) \times 300 \times 10^{-9}] / 26.4 \times 10^{-6} = 258 \text{ mA}_{P-P}$$

The third specification for an inductor is the peak current rating, normally given as the point at which the inductance drops off by a given percentage due to saturation of the core. The worst-case peak current occurs at maximum input voltage and at minimum inductance, and can be determined with the equation from the Design Considerations section:

$$I_{L(PEAK)} = I_F + \frac{\Delta i_{L(MAX)}}{2}$$

$$I_{L(PEAK)} = 0.35 + 0.258 / 2 = 479 \text{ mA}$$

For this example the peak current rating of the inductor should be greater than 479 mA. In the case of a short circuit across the LED array, the LM3402 will continue to deliver rated current through the short but will reduce the output voltage to equal the CS pin voltage of 200 mV. Worst-case peak current in this condition is equal to:

$$\begin{aligned}\Delta i_{L(\text{LED-SHORT})} &= [(26.4 - 0.2) \times 300 \times 10^{-9}] / 26.4 \times 10^{-6} \\ &= 298 \text{ mA}_{\text{P-P}} \\ I_{L(\text{PEAK})} &= 0.35 + 0.149 = 499 \text{ mA}\end{aligned}$$

In the case of a short at the switch node, the output, or from the CS pin to ground the short circuit current limit will engage at a typical peak current of 735 mA. In order to prevent inductor saturation during these short circuits the inductor's peak current rating must be above 735 mA. The device selected is an off-the-shelf inductor rated 33 $\mu\text{H} \pm 20\%$ with a DCR of 96 m Ω and a peak current rating of 0.82A. The physical dimensions of this inductor are 7.0 x 7.0 x 4.5 mm.

R_{SNS}

The current sensing resistor value can be determined by re-arranging the expression for average LED current from the LED Current Accuracy section:

$$R_{\text{SNS}} = \frac{0.2 \times L}{I_{\text{F}} \times L + V_{\text{O}} \times t_{\text{SNS}} - \frac{V_{\text{IN}} - V_{\text{O}}}{2} \times t_{\text{ON}}}$$

$$R_{\text{SNS}} = 0.74\Omega, t_{\text{SNS}} = 220 \text{ ns}$$

Sub-1 Ω resistors are available in both 1% and 5% tolerance. A 1%, 0.75 Ω resistor will give the best accuracy of the average LED current. To determine the resistor size the power dissipation can be calculated as:

$$\begin{aligned}P_{\text{SNS}} &= (I_{\text{F}})^2 \times R_{\text{SNS}} \\ P_{\text{SNS}} &= 0.35^2 \times 0.75 = 92 \text{ mW}\end{aligned}$$

Standard 0805 size resistors are rated to 125 mW and will be suitable for this application.

To select the proper output capacitor the equation from Buck Regulators with Output Capacitors is re-arranged to yield the following:

$$Z_{\text{C}} = \frac{\Delta i_{\text{F}}}{\Delta i_{\text{L}} - \Delta i_{\text{F}}} \times r_{\text{D}}$$

The target tolerance for LED ripple current is $\pm 5\%$ or $10\%_{\text{P-P}}$. $P = 35 \text{ mA}_{\text{P-P}}$, and the LED datasheet gives a typical value for r_{D} of 1.0 Ω at 350 mA. The required capacitor impedance to reduce the worst-case inductor ripple current of 258 mA $_{\text{P-P}}$ is therefore:

$$Z_{\text{C}} = [0.035 / (0.258 - 0.035)] \times 1.0 = 0.157\Omega$$

A ceramic capacitor will be used and the required capacitance is selected based on the impedance at 468 kHz:

$$C_{\text{O}} = 1 / (2 \times \pi \times 0.157 \times 4.68 \times 10^5) = 2.18 \mu\text{F}$$

This calculation assumes that impedance due to the equivalent series resistance (ESR) and equivalent series inductance (ESL) of C_{O} is negligible. The closest 10% tolerance capacitor value is 2.2 μF . The capacitor used should be rated to 10V or more and have an X7R dielectric. Several manufacturers produce ceramic capacitors with these specifications in the 0805 case size. A typical value for ESR of 1 m Ω can be read from the curve of impedance vs. frequency in the product datasheet.

INPUT CAPACITOR

Following the calculations from the Input Capacitor section, $\Delta V_{\text{IN}(\text{MAX})}$ will be $1\%_{\text{P-P}} = 240 \text{ mV}$. The minimum required capacitance is:

$$C_{\text{IN}(\text{MIN})} = (0.35 \times 300 \times 10^{-9}) / 0.24 = 438 \text{ nF}$$

In expectation that more capacitance will be needed to prevent power supply interaction a 1.0 μF ceramic capacitor rated to 50V with X7R dielectric in a 1206 case size will be used. From the Design Considerations section, input rms current is:

$$I_{\text{IN-RMS}} = 0.35 \times \text{Sqrt}(0.154 \times 0.846) = 126 \text{ mA}$$

Ripple current ratings for 1206 size ceramic capacitors are typically higher than 1A, more than enough for this design.

RECIRCULATING DIODE

The first parameter for D1 which must be determined is the reverse voltage rating. Schottky diodes are available at reverse ratings of 30V and 40V, often in the same package, with the same forward current rating. To account for ringing a 40V Schottky will be used.

The next parameters to be determined are the forward current rating and case size. In this example the low duty cycle ($D = 3.7 / 24 = 15\%$) requires the recirculating diode D1 to carry the load current much longer than the internal power MOS-FET of the LM3402. The estimated average diode current is:

$$I_{\text{D}} = 0.35 \times 0.85 = 298 \text{ mA}$$

Schottky diodes are available at forward current ratings of 0.5A, however the current rating often assumes a 25 $^{\circ}\text{C}$ ambient temperature and does not take into account the application restrictions on temperature rise. A diode rated for higher current may be needed to keep the temperature rise below 40 $^{\circ}\text{C}$. To determine the proper case size, the dissipation and temperature rise in D1 can be calculated as shown in the Design Considerations section. V_{D} for a small case size such as SOD-123 in a 40V, 0.5A Schottky diode at 350 mA is approximately 0.4V and the θ_{JA} is 206 $^{\circ}\text{C}/\text{W}$. Power dissipation and temperature rise can be calculated as:

$$\begin{aligned}P_{\text{D}} &= 0.298 \times 0.4 = 119 \text{ mW} \\ T_{\text{RISE}} &= 0.119 \times 206 = 24.5^{\circ}\text{C}\end{aligned}$$

According to these calculations the SOD-123 diode will meet the requirements. Heating and dissipation are among the fac-

tors most difficult to predict in converter design. If possible, a footprint should be used that is capable of accepting both SOD-123 and a larger case size, such as SMA. A larger diode with a higher forward current rating will generally have a lower forward voltage, reducing dissipation, as well as having a lower θ_{JA} , reducing temperature rise.

C_B and C_F

The bootstrap capacitor C_B should always be a 10 nF ceramic capacitor with X7R dielectric. A 25V rating is appropriate for all application circuits. The linear regulator filter capacitor C_F should always be a 100 nF ceramic capacitor, also with X7R dielectric and a 25V rating.

EFFICIENCY

To estimate the electrical efficiency of this example the power dissipation in each current carrying element can be calculated and summed. This term should not be confused with the optical efficacy of the circuit, which depends upon the LEDs themselves.

Total output power, P_O , is calculated as:

$$P_O = I_F \times V_O = 0.35 \times 3.7 = 1.295W$$

Conduction loss, P_C , in the internal MOSFET:

$$P_C = (I_F^2 \times R_{DS(ON)}) \times D = (0.35^2 \times 1.5) \times 0.154 = 28 \text{ mW}$$

Gate charging and VCC loss, P_G , in the gate drive and linear regulator:

$$P_G = (I_{IN-OP} + f_{SW} \times Q_G) \times V_{IN}$$

$$P_G = (600 \times 10^{-6} + 468000 \times 3 \times 10^{-9}) \times 24 = 48 \text{ mW}$$

Switching loss, P_S , in the internal MOSFET:

$$P_S = 0.5 \times V_{IN} \times I_F \times (t_R + t_F) \times f_{SW}$$

$$P_S = 0.5 \times 24 \times 0.35 \times (40 \times 10^{-9}) \times 468000 = 78 \text{ mW}$$

AC rms current loss, P_{CIN} , in the input capacitor:

$$P_{CIN} = I_{IN(rms)}^2 \times ESR = (0.126)^2 \times 0.006 = 0.1 \text{ mW (negligible)}$$

DCR loss, P_L , in the inductor

$$P_L = I_F^2 \times DCR = 0.35^2 \times 0.096 = 11.8 \text{ mW}$$

Recirculating diode loss, $P_D = 119 \text{ mW}$

Current Sense Resistor Loss, $P_{SNS} = 92 \text{ mW}$

Electrical efficiency, $\eta = P_O / (P_O + \text{Sum of all loss terms}) = 1.295 / (1.295 + 0.377) = 77\%$

DIE TEMPERATURE

$$T_{LM3402} = (P_C + P_G + P_S) \times \theta_{JA}$$

$$T_{LM3402} = (0.028 + 0.05 + 0.078) \times 200 = 31^\circ\text{C}$$

Design Example 2: LM3402HV

The second example application is an RGB backlight for a flat screen monitor. A separate boost regulator provides a 60V

$\pm 5\%$ DC input rail that feeds three LM3402HV current regulators to drive one series array each of red, green, and blue 1W LEDs. The target for average LED current is 350 mA $\pm 5\%$ in each string. The monitor will adjust the color temperature dynamically, requiring fast PWM dimming of each string with external, parallel MOSFETs. 1W green and blue InGaP LEDs have a typical forward voltage of 3.5V, however red LEDs use AlInGaP technology with a typical forward voltage of 2.9V. In order to match color properly the design requires 14 green LEDs, twice as many as needed for the red and blue LEDs. This example will follow the design for the green LED array, providing the necessary information to repeat the exercise for the blue and red LED arrays. The circuit schematic for Design Example 2 is the same as the Typical Application on the front page. The bill of materials (green array only) can be found in Table 2 at the end of this datasheet.

OUTPUT VOLTAGE

$$\text{Green Array: } V_{O(G)} = 14 \times 3.5 + 0.2 = 49.2V$$

$$\text{Blue Array: } V_{O(B)} = 7 \times 3.5 + 0.2 = 24.7V$$

$$\text{Red Array: } V_{O(R)} = 7 \times 2.9 + 0.2 = 20.5V$$

R_{ON} and t_{ON}

A compromise in switching frequency is needed in this application to balance the requirements of magnetics size and efficiency. The high duty cycle translates into large conduction losses and high temperature rise in the IC. For best response to a PWM dimming signal this circuit will not use an output capacitor; hence a moderate switching frequency of 300 kHz will keep the inductance from becoming so large that a custom-wound inductor is needed. This design will use only surface mount components, and the selection of off-the-shelf SMT inductors for switching regulators is poor at 1000 μH and above. R_{ON} is selected from the equation for switching frequency as follows:

$$R_{ON} = \frac{V_O}{1.34 \times 10^{-10} \times f_{SW}}$$

$$R_{ON} = 49.2 / (1.34 \times 10^{-10} \times 3 \times 10^5) = 1224 \text{ k}\Omega$$

The closest 1% tolerance resistor is 1.21 M Ω . The switching frequency and on-time of the circuit can then be found using the equations relating R_{ON} and t_{ON} to f_{SW} :

$$f_{SW} = 49.2 / (1210000 \times 1.34 \times 10^{-10}) = 303 \text{ kHz}$$

$$t_{ON} = (1.34 \times 10^{-10} \times 1210000) / 60 = 2.7 \mu\text{s}$$

USING AN OUTPUT CAPACITOR

This application is dominated by the need for fast PWM dimming, requiring a circuit without any output capacitance.

OUTPUT INDUCTOR

In this example the ripple current through the LED array and the inductor are equal. Inductance is selected to give the smallest ripple current possible while still providing enough ΔV_{SNS} signal for the CS comparator to operate correctly. De-

signing to a desired Δv_{SNS} of 25 mV and assuming that the average inductor current will equal the desired average LED current of 350 mA yields the target current ripple in the inductor and LEDs:

$$\Delta i_F = \Delta i_L = \Delta v_{SNS} / R_{SNS}, R_{SNS} = V_{SNS} / I_F$$

$$\Delta i_F = 0.025 / 0.57 = 43.8 \text{ mA}$$

With the target ripple current determined the inductance can be chosen:

$$L_{MIN} = \frac{V_{IN} - V_O}{\Delta i_F} \times t_{ON}$$

$$L_{MIN} = [(60 - 49.2) \times 2.7 \times 10^{-6}] / (0.044) = 663 \mu\text{H}$$

The closest standard inductor value is 680 μH . As with the previous example, the average current rating should be greater than 350 mA. Separation between the LM3402HV drivers and the LED arrays mean that heat from the inductor will not threaten the lifetime of the LEDs, but an overheated inductor could still cause the LM3402HV to enter thermal shutdown.

The inductance itself of the standard part chosen is $\pm 20\%$. With this tolerance the typical, minimum, and maximum inductor current ripples can be calculated:

$$\Delta i_{F(TYP)} = [(60 - 49.2) \times 2.7 \times 10^{-6}] / 680 \times 10^{-6}$$

$$= 43 \text{ mA}_{P-P}$$

$$\Delta i_{F(MIN)} = [(60 - 49.2) \times 2.7 \times 10^{-6}] / 816 \times 10^{-6}$$

$$= 36 \text{ mA}_{P-P}$$

$$\Delta i_{F(MAX)} = [(60 - 49.2) \times 2.7 \times 10^{-6}] / 544 \times 10^{-6}$$

$$= 54 \text{ mA}_{P-P}$$

The peak LED/inductor current is then estimated:

$$I_{L(PEAK)} = I_L + [\Delta i_{L(MAX)}] / 2$$

$$I_{L(PEAK)} = 0.35 + 0.027 = 377 \text{ mA}$$

In the case of a short circuit across the LED array, the LM3402HV will continue to deliver rated current through the short but will reduce the output voltage to equal the CS pin voltage of 200 mV. Worst-case peak current in this condition would be equal to:

$$\Delta i_{F(LED-SHORT)} = [(63 - 0.2) \times 2.7 \times 10^{-6}] / 544 \times 10^{-6}$$

$$= 314 \text{ mA}_{P-P}$$

$$I_{F(PEAK)} = 0.35 + 0.156 = 506 \text{ mA}$$

In the case of a short at the switch node, the output, or from the CS pin to ground the short circuit current limit will engage at a typical peak current of 735 mA. In order to prevent inductor saturation during these fault conditions the inductor's peak current rating must be above 735 mA. A 680 μH off-the-

shelf inductor rated to 1.2A (peak) and 0.72A (average) with a DCR of 1.1 Ω will be used for the green LED array.

R_{SNS}

A preliminary value for R_{SNS} was determined in selecting Δi_L . This value should be re-evaluated based on the calculations for Δi_F :

$$R_{SNS} = \frac{0.2 \times L}{I_F \times L + V_O \times t_{SNS} - \frac{V_{IN} - V_O}{2} \times t_{ON}}$$

Sub-1 Ω resistors are available in both 1% and 5% tolerance. A 1%, 0.56 Ω device is the closest value, and a 0.125W, 0805 size device will handle the power dissipation of 69 mW. With the resistance selected, the average value of LED current is re-calculated to ensure that current is within the $\pm 5\%$ tolerance requirement. From the expression for LED current accuracy:

$$I_F = 0.19 / 0.56 + 0.043 / 2 = 361 \text{ mA}, 3\% \text{ above } 350 \text{ mA}$$

INPUT CAPACITOR

Following the calculations from the Input Capacitor section, $\Delta v_{IN(MAX)}$ will be 1%_{P-P} = 600 mV. The minimum required capacitance is:

$$C_{IN(MIN)} = (0.35 \times 2.7 \times 10^{-6}) / 0.6 = 1.6 \mu\text{F}$$

In expectation that more capacitance will be needed to prevent power supply interaction a 2.2 μF ceramic capacitor rated to 100V with X7R dielectric in an 1812 case size will be used. From the Design Considerations section, input rms current is:

$$I_{IN-RMS} = 0.35 \times \text{Sqrt}(0.82 \times 0.18) = 134 \text{ mA}$$

Ripple current ratings for 1812 size ceramic capacitors are typically higher than 2A, more than enough for this design.

RECIRCULATING DIODE

The input voltage of 60V $\pm 5\%$ requires Schottky diodes with a reverse voltage rating greater than 60V. Some manufacturers provide Schottky diodes with ratings of 70, 80 or 90V; however the next highest standard voltage rating is 100V. Selecting a 100V rated diode provides a large safety margin for the ringing of the switch node and also makes cross-referencing of diodes from different vendors easier.

The next parameters to be determined are the forward current rating and case size. In this example the high duty cycle ($D = 49.2 / 60 = 82\%$) places less thermal stress on D1 and more on the internal power MOSFET of the LM3402. The estimated average diode current is:

$$I_D = 0.361 \times 0.18 = 65 \text{ mA}$$

A Schottky with a forward current rating of 0.5A would be adequate, however at 100V the majority of diodes have a minimum forward current rating of 1A. To determine the proper case size, the dissipation and temperature rise in D1 can be calculated as shown in the Design Considerations section. V_D for a small case size such as SOD-123F in a 100V, 1A

Schottky diode at 350 mA is approximately 0.65V and the θ_{JA} is 88°C/W. Power dissipation and temperature rise can be calculated as:

$$P_D = 0.065 \times 0.65 = 42 \text{ mW}$$

$$T_{RISE} = 0.042 \times 88 = 4^\circ\text{C}$$

C_B AND C_F

The bootstrap capacitor C_B should always be a 10 nF ceramic capacitor with X7R dielectric. A 25V rating is appropriate for all application circuits. The linear regulator filter capacitor C_F should always be a 100 nF ceramic capacitor, also with X7R dielectric and a 25V rating.

EFFICIENCY

To estimate the electrical efficiency of this example the power dissipation in each current carrying element can be calculated and summed. Electrical efficiency, η , should not be confused with the optical efficacy of the circuit, which depends upon the LEDs themselves.

Total output power, P_O , is calculated as:

$$P_O = I_F \times V_O = 0.361 \times 49.2 = 17.76\text{W}$$

Conduction loss, P_C , in the internal MOSFET:

$$P_C = (I_F^2 \times R_{DS(ON)}) \times D = (0.361^2 \times 1.5) \times 0.82 = 160 \text{ mW}$$

Gate charging and VCC loss, P_G , in the gate drive and linear regulator:

$$P_G = (I_{IN-OP} + f_{SW} \times Q_G) \times V_{IN}$$

$$P_G = (600 \times 10^{-6} + 3 \times 10^5 \times 3 \times 10^{-9}) \times 60 = 90 \text{ mW}$$

Switching loss, P_S , in the internal MOSFET:

$$P_S = 0.5 \times V_{IN} \times I_F \times (t_R + t_F) \times f_{SW}$$

$$P_S = 0.5 \times 60 \times 0.361 \times 40 \times 10^{-9} \times 3 \times 10^5 = 130 \text{ mW}$$

AC rms current loss, P_{CIN} , in the input capacitor:

$$P_{CIN} = I_{IN(rms)}^2 \times ESR = (0.134)^2 \times 0.006 = 0.1 \text{ mW (negligible)}$$

DCR loss, P_L , in the inductor

$$P_L = I_F^2 \times DCR = 0.35^2 \times 1.1 = 135 \text{ mW}$$

Recirculating diode loss, $P_D = 42 \text{ mW}$

Current Sense Resistor Loss, $P_{SNS} = 69 \text{ mW}$

$$\text{Electrical efficiency, } \eta = P_O / (P_O + \text{Sum of all loss terms}) = 17.76 / (17.76 + 0.62) = 96\%$$

Temperature Rise in the LM3402HV IC is calculated as:

$$T_{LM3402} = (P_C + P_G + P_S) \times \theta_{JA} = (0.16 + 0.084 + 0.13) \times 200 = 74.8^\circ\text{C}$$

Layout Considerations

The performance of any switching converter depends as much upon the layout of the PCB as the component selection. The following guidelines will help the user design a circuit with maximum rejection of outside EMI and minimum generation of unwanted EMI.

COMPACT LAYOUT

Parasitic inductance can be reduced by keeping the power path components close together and keeping the area of the loops that high currents travel small. Short, thick traces or copper pours (shapes) are best. In particular, the switch node (where L1, D1, and the SW pin connect) should be just large enough to connect all three components without excessive heating from the current it carries. The LM3402/02HV operates in two distinct cycles whose high current paths are shown in Figure 6:

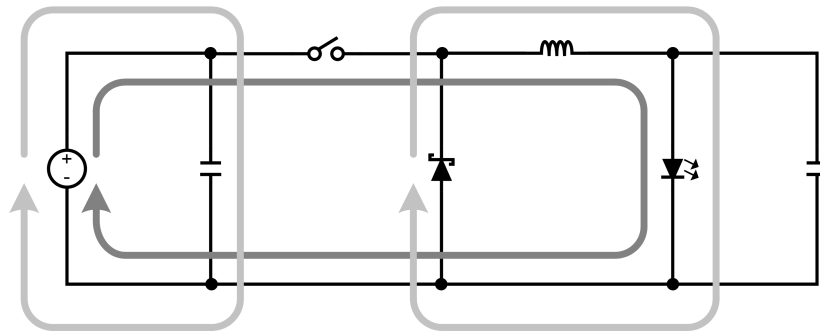

20192128

FIGURE 6. Buck Converter Current Loops

The dark grey, inner loop represents the high current path during the MOSFET on-time. The light grey, outer loop represents the high current path during the off-time.

GROUND PLANE AND SHAPE ROUTING

The diagram of Figure 6 is also useful for analyzing the flow of continuous current vs. the flow of pulsating currents. The circuit paths with current flow during both the on-time and off-

time are considered to be continuous current, while those that carry current during the on-time or off-time only are pulsating currents. Preference in routing should be given to the pulsating current paths, as these are the portions of the circuit most likely to emit EMI. The ground plane of a PCB is a conductor and return path, and it is susceptible to noise injection just as any other circuit path. The continuous current paths on the ground net can be routed on the system ground plane with

less risk of injecting noise into other circuits. The path between the input source and the input capacitor and the path between the recirculating diode and the LEDs/current sense resistor are examples of continuous current paths. In contrast, the path between the recirculating diode and the input capacitor carries a large pulsating current. This path should be routed with a short, thick shape, preferably on the component side of the PCB. Multiple vias in parallel should be used right at the pad of the input capacitor to connect the component side shapes to the ground plane. A second pulsating current loop that is often ignored is the gate drive loop formed by the SW and BOOT pins and capacitor CB. To minimize this loop at the EMI it generates, keep CB close to the SW and BOOT pins.

CURRENT SENSING

The CS pin is a high-impedance input, and the loop created by R_{SNS} , R_Z (if used), the CS pin and ground should be made

as small as possible to maximize noise rejection. R_{SNS} should therefore be placed as close as possible to the CS and GND pins of the IC.

REMOTE LED ARRAYS

In some applications the LED or LED array can be far away (several inches or more) from the LM3402/02HV, or on a separate PCB connected by a wiring harness. When an output capacitor is used and the LED array is large or separated from the rest of the converter, the output capacitor should be placed close to the LEDs to reduce the effects of parasitic inductance on the AC impedance of the capacitor. The current sense resistor should remain on the same PCB, close to the LM3402/02HV.

TABLE 1. BOM for Design Example 1

ID	Part Number	Type	Size	Parameters	Qty	Vendor
U1	LM3402	LED Driver	MSOP-8	40V, 0.5A	1	NSC
L1	SLF7045T-330MR82	Inductor	7.0x7.0 x4.5mm	33 μ H, 0.82A, 96m Ω	1	TDK
D1	CMHSH5-4	Schottky Diode	SOD-123	40V, 0.5A	1	Central Semi
Cf	VJ0805Y104KXXAT	Capacitor	0805	100nF 10%	1	Vishay
Cb	VJ0805Y103KXXAT	Capacitor	0805	10nF 10%	1	Vishay
Cin	C3216X7R1H105M	Capacitor	1206	1 μ F 50V	1	TDK
Co	C2012X7R1A225M	Capacitor	0805	2.2 μ F 10V	1	TDK
Rsns	ERJ6BQFR75V	Resistor	0805	0.75 Ω 1%	1	Panasonic
Ron	CRCW08055902F	Resistor	0805	59.0 k Ω 1%	1	Vishay

TABLE 2. BOM for Design Example 2

ID	Part Number	Type	Size	Parameters	Qty	Vendor
U1	LM3402HV	LED Driver	MSOP-8	75V, 0.5A	1	NSC
L1	DO5022P-684	Inductor	18.5x15.2 x7.1mm	680 μ H, 1.2A, 1.1 Ω	1	Coilcraft
D1	CMMSH1-100	Schottky Diode	SOD-123F	100V, 1A	1	Central Semi
Cf	VJ0805Y104KXXAT	Capacitor	0805	100nF 10%	1	Vishay
Cb	VJ0805Y103KXXAT	Capacitor	0805	10nF 10%	1	Vishay
Cin	C4532X7R2A225M	Capacitor	1812	2.2 μ F 100V	1	TDK
Rsns	ERJ6BQFR56V	Resistor	0805	0.56 Ω 1%	1	Panasonic
Ron	CRCW08051214F	Resistor	0805	1.21M Ω 1%	1	Vishay

Physical Dimensions inches (millimeters) unless otherwise noted

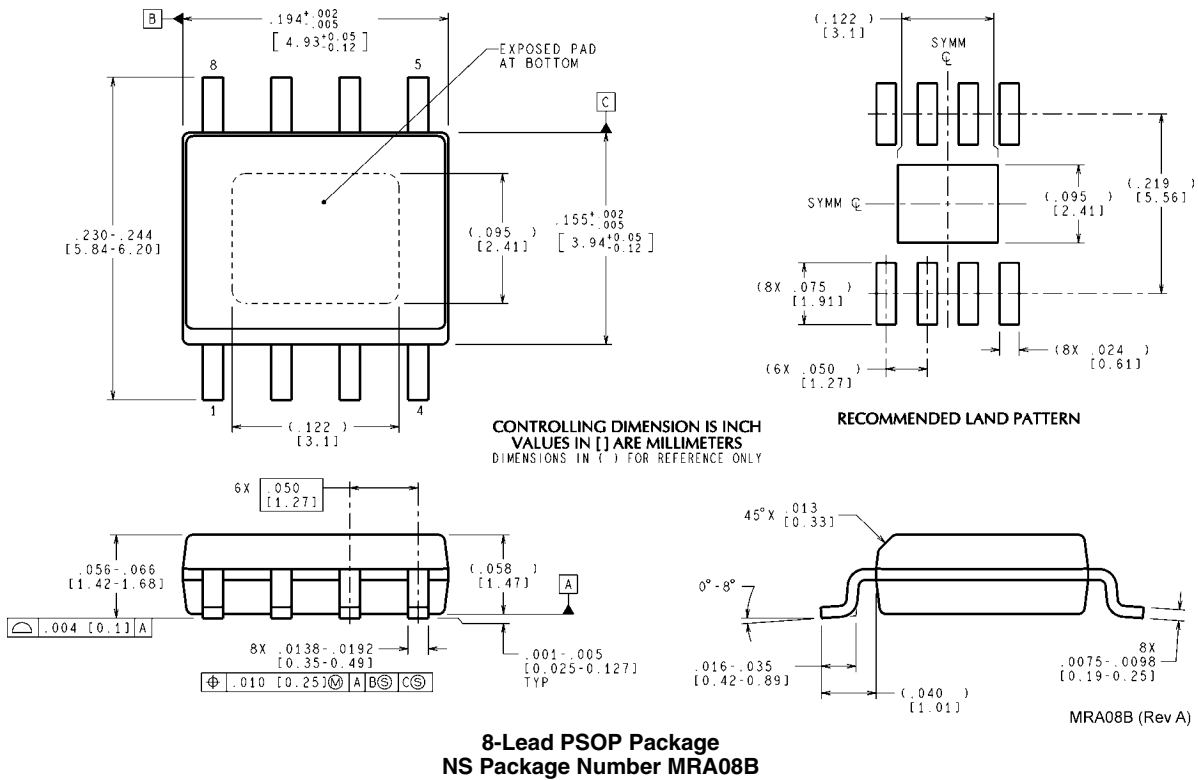
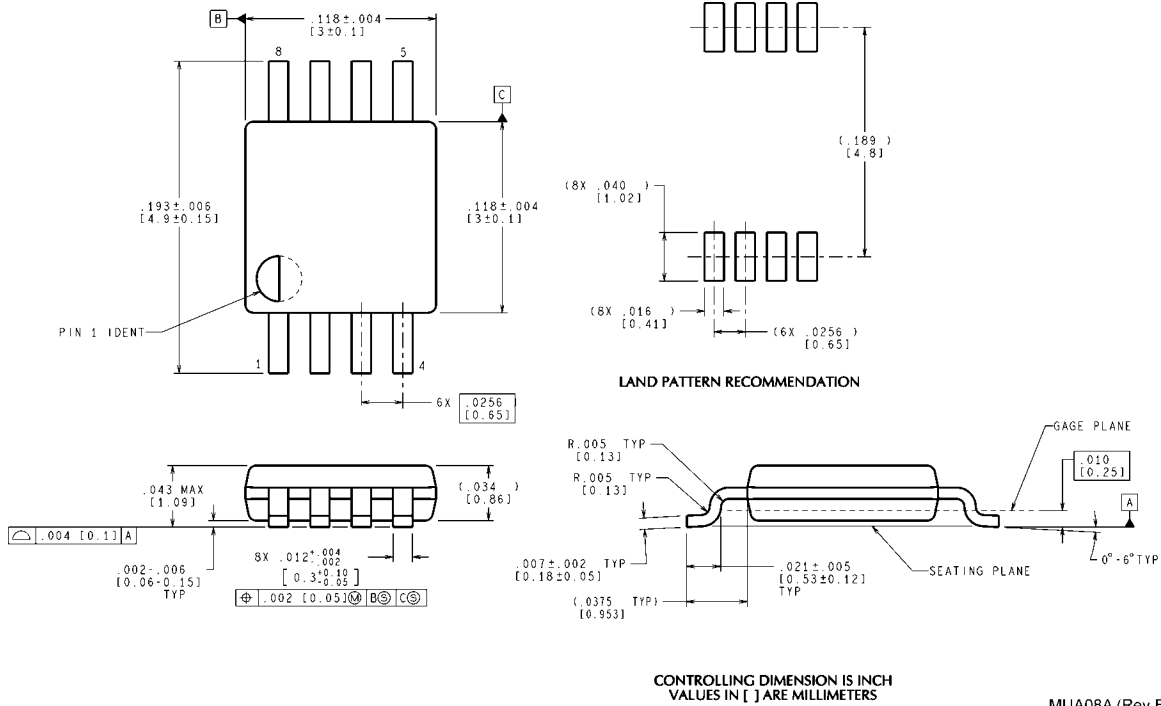

Notes

THE CONTENTS OF THIS DOCUMENT ARE PROVIDED IN CONNECTION WITH NATIONAL SEMICONDUCTOR CORPORATION ("NATIONAL") PRODUCTS. NATIONAL MAKES NO REPRESENTATIONS OR WARRANTIES WITH RESPECT TO THE ACCURACY OR COMPLETENESS OF THE CONTENTS OF THIS PUBLICATION AND RESERVES THE RIGHT TO MAKE CHANGES TO SPECIFICATIONS AND PRODUCT DESCRIPTIONS AT ANY TIME WITHOUT NOTICE. NO LICENSE, WHETHER EXPRESS, IMPLIED, ARISING BY ESTOPPEL OR OTHERWISE, TO ANY INTELLECTUAL PROPERTY RIGHTS IS GRANTED BY THIS DOCUMENT.

TESTING AND OTHER QUALITY CONTROLS ARE USED TO THE EXTENT NATIONAL DEEMS NECESSARY TO SUPPORT NATIONAL'S PRODUCT WARRANTY. EXCEPT WHERE MANDATED BY GOVERNMENT REQUIREMENTS, TESTING OF ALL PARAMETERS OF EACH PRODUCT IS NOT NECESSARILY PERFORMED. NATIONAL ASSUMES NO LIABILITY FOR APPLICATIONS ASSISTANCE OR BUYER PRODUCT DESIGN. BUYERS ARE RESPONSIBLE FOR THEIR PRODUCTS AND APPLICATIONS USING NATIONAL COMPONENTS. PRIOR TO USING OR DISTRIBUTING ANY PRODUCTS THAT INCLUDE NATIONAL COMPONENTS, BUYERS SHOULD PROVIDE ADEQUATE DESIGN, TESTING AND OPERATING SAFEGUARDS.

EXCEPT AS PROVIDED IN NATIONAL'S TERMS AND CONDITIONS OF SALE FOR SUCH PRODUCTS, NATIONAL ASSUMES NO LIABILITY WHATSOEVER, AND NATIONAL DISCLAIMS ANY EXPRESS OR IMPLIED WARRANTY RELATING TO THE SALE AND/OR USE OF NATIONAL PRODUCTS INCLUDING LIABILITY OR WARRANTIES RELATING TO FITNESS FOR A PARTICULAR PURPOSE, MERCHANTABILITY, OR INFRINGEMENT OF ANY PATENT, COPYRIGHT OR OTHER INTELLECTUAL PROPERTY RIGHT.

LIFE SUPPORT POLICY

NATIONAL'S PRODUCTS ARE NOT AUTHORIZED FOR USE AS CRITICAL COMPONENTS IN LIFE SUPPORT DEVICES OR SYSTEMS WITHOUT THE EXPRESS PRIOR WRITTEN APPROVAL OF THE CHIEF EXECUTIVE OFFICER AND GENERAL COUNSEL OF NATIONAL SEMICONDUCTOR CORPORATION. As used herein:

Life support devices or systems are devices which (a) are intended for surgical implant into the body, or (b) support or sustain life and whose failure to perform when properly used in accordance with instructions for use provided in the labeling can be reasonably expected to result in a significant injury to the user. A critical component is any component in a life support device or system whose failure to perform can be reasonably expected to cause the failure of the life support device or system or to affect its safety or effectiveness.

National Semiconductor and the National Semiconductor logo are registered trademarks of National Semiconductor Corporation. All other brand or product names may be trademarks or registered trademarks of their respective holders.

Copyright© 2007 National Semiconductor Corporation

For the most current product information visit us at www.national.com



**National Semiconductor
Americas Customer
Support Center**
Email:
new.feedback@nsc.com
Tel: 1-800-272-9959

**National Semiconductor Europe
Customer Support Center**
Fax: +49 (0) 180-530-85-86
Email: europe.support@nsc.com
Deutsch Tel: +49 (0) 69 9508 6208
English Tel: +49 (0) 870 24 0 2171
Français Tel: +33 (0) 1 41 91 8790

**National Semiconductor Asia
Pacific Customer Support Center**
Email: ap.support@nsc.com

**National Semiconductor Japan
Customer Support Center**
Fax: 81-3-5639-7507
Email: jpn.feedback@nsc.com
Tel: 81-3-5639-7560